



**THE DATASHEET OF  
QLS08ZH-NT**



# QLS08ZH

## Quarter-Brick DC-DC Converter

The **QLS08ZH** is a new high-density, single-output dc-dc converter providing onboard conversion of standard telecom and datacom input voltages into isolated low voltage outputs in a through-hole mounting package. High efficiencies and a patent-pending board design significantly improve thermal characteristics by evening out hot spots and enhance product reliability.



### Key Features & Benefits

- RoHS lead solder exemption compliant
- Cost-effective, single board design
- Low profile – 11mm height
- Input/output isolation: 1500VDC, Basic insulation
- High efficiency - 90% at full load
- Start-up into high capacitive load
- Low conducted and radiated EMI
- Output overcurrent protection
- Output overvoltage protection
- Back drive protection
- Over temperature protection
- Remote sense
- Set point accuracy  $\pm 1\%$
- Remote on/off (primary referenced), positive or negative logic
- Output voltage trim adjust  $\pm 10\%$
- UL 1950 Recognition, CSA 22.2 No. 950-95 certification, TUV IEC950

### Application

- Distributed power architectures
- Telecommunications equipment
- LAN/WAN
- Data processing

# QLS08ZH

## 1. MODEL SELECTION

MODEL	INPUT VOLTAGE VDC	INPUT CURRENT, MAX ADC	OUTPUT VOLTAGE VOUT, VDC	OUTPUT RATED CURRENT I <sub>RATED</sub> , ADC	OUTPUT RIPPLE/NOISE, MV P-P	TYPICAL EFFICIENCY @ I <sub>RATED</sub> , %
QLS08ZH	36-75	4.8	12.0	8	150	90

**NOTE:** This product is intended for integration into end-use equipment. All the required procedures for CE marking of end-use equipment should be followed.

Model numbers highlighted in yellow or shaded are not recommended for new designs.

## 2. ELECTRICAL SPECIFICATIONS

Stresses in excess of the absolute maximum ratings may cause performance degradation, adversely affect long-term reliability, and cause permanent damage to the converter. All specifications apply over specified input voltage, output load, and temperature range, unless otherwise noted.

PARAMETER	CONDITIONS / DESCRIPTION	MIN	TYP	MAX	UNITS
<i>Absolute Maximum Ratings</i>					
Input voltage	Continuous Transient, 100ms			75 100	VDC VDC
Operating Temperature	PC Board Temperature	-40		110	°C
Storage Temperature		-40		125	°C
ON/OFF Control Voltage	Referenced to -Vin			50	VDC
<i>Environmental and Mechanical Specifications</i>					
Shock	Halfsine wave, 3 axes	50			g
Sinusoidal Vibration	GR-63-Core, Section 5.4.2	1			g
Weight			1.2/35		Oz/g
Water Washing	Standard process		Yes		
MTBF	Per Bellcore TR-NWT-000332		1,980		kHrs
<i>Isolation Specifications</i>					
Insulation Safety Rating			Basic		
Isolation Voltage		1500			VDC
Isolation Resistance		10			MOhm
Isolation Capacitance		1100			pF
<i>Input Specifications</i>					
Input Voltage	Continuous	36	48	75	VDC
Turn-On Input Voltage	Ramping Up		33		VDC
Turn-Off Input Voltage	Ramping Down		32		VDC
Turn-On Time	To Output Regulation Band 100% Resistive Load		5	10	ms
Input Reflected Ripple Current	Full Load, 12µH source inductance			60	mA p-p
Inrush Transient	Vin=Vin.max			0.1	A <sup>2</sup> s
<i>Output Specifications</i>					
Output Voltage Setpoint Accuracy	Vin=Vin.nom, Full Load	-1		1	%Vout
Output Current <sup>1</sup>	See selection chart for Irated	0		100	%Irated
Line Regulation	Vin.min to Vin.max, Irated			0.2	%Vout
Load Regulation	Vin=Vin.nom, 10% to 100%Irated			0.2	%Vout

Total output voltage regulation	Over all input voltage, load, and temperature conditions	-2	2	%Vout
Remote Sense Headroom			10	%Vout
Dynamic Regulation	50-75% load step change			
Peak Deviation			5	%Vout
Settling Time	to 1% error band		150	μs
Admissible Load Capacitance	I <sub>rated</sub> , Nom V <sub>in</sub>	20,000		μF
Output Current Limit Threshold <sup>2</sup>	V <sub>out</sub> ≤ 0.97V <sub>out,nom</sub>	110	140	%I <sub>rated</sub>
Switching Frequency			270	kHz
Overvoltage Protection, Non Latching	Over all input voltage and load conditions	120	140	%Vout
Trim Range	I <sub>rated</sub> , V <sub>in</sub> =V <sub>nom</sub>	90	110	%Vout
<b>Feature Specifications</b>				
Shutdown (ON/OFF)				
Negative Logic	On/Off signal is low – converter is ON			
Converter ON		-1.0	1.8	
Source Current	ON/OFF pin is connected to -V <sub>in</sub>		1	mADC
Converter OFF		3.5	50	VDC
Open Circuit Voltage	ON/OFF pin is floating		5	VDC
Positive Logic	On/Off signal is low – converter is OFF			
Converter ON		3.5	50	VDC
Open Circuit Voltage	ON/OFF pin is floating		5	VDC
Converter OFF		-1.0	1.8	VDC
Source Current	ON/OFF pin is connected to -V <sub>in</sub>		1	mADC
Over temperature Protection	Average board temperature		105	°C

<sup>1)</sup> At I<sub>out</sub><10% I<sub>out</sub>, the output may contain low frequency component that exceeds ripple specifications.

<sup>2)</sup> Overcurrent protection is non-latching with auto recovery.

### 3. OPERATIONS

#### 2.1 OUTPUT VOLTAGE TRIM

The trim feature allows the user to adjust the output voltage from the nominal. This can be used to accommodate a different requirement or to do production margin testing.

#### 2.2 INDUSTRY STANDARD TRIM

The converters trim up with a resistor from the TRIM pin to the +Sense pin and trim down with a resistor from the TRIM pin to the -Sense pin as shown in Figure 1.

# QLS08ZH

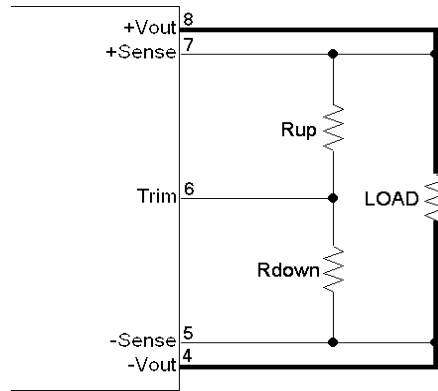

Figure 1. QLS08ZH Positive Trim Schematic

The equations below determine the trim resistor value required to achieve a  $\Delta V$  change in the output voltage.

$$R_{UP} = 5.11 \left( \frac{V_{out}(100 + \Delta V\%)}{1.225\Delta V\%} - \frac{100 + 2\Delta V\%}{\Delta V\%} \right) \text{ k}\Omega$$

$$R_{DOWN} = 5.11 \left( \frac{100}{\Delta V\%} - 2 \right) \text{ k}\Omega$$

Where  $\Delta V\%$  is the output voltage change expressed in percent's of the nominal output voltage,  $V_{out}$ .

#### NOTES:

1. When the output voltage is trimmed up, the output power from the converter must not exceed its maximum rating. The power is determined by measuring the output voltage on the output pins, and multiplying it by the output current.
2. In order to avoid creating apparent load regulation degradation, it is important that the trim resistors are connected directly to the remote sense pins, and not to the load or to traces going to the load.
3. The QLS08ZH converter will trim down further than the 10% limit. In general, this is permissible. The user must confirm that the results are acceptable in the application.

## 2.3 SAFETY CONSIDERATIONS

The QLS08ZH converter features 1500 Volt DC isolation from input to output. The input-to-output resistance is greater than 10M $\Omega$ . This converter is provided with Basic insulation between input and output circuits according to all IEC60950 based standards. Nevertheless, if the system using the converter needs to receive safety agency approval, certain rules must be followed in the design of the system. In particular, all of the creepage and clearance requirements of the end-use safety requirements must be observed. These documents include UL60950 - CSA60950-00 and EN60950, although other or additional requirements may be needed for specific applications.

The QLS08ZH converter has no internal fuse. The external fuse must be provided to protect the system from catastrophic failure as shown in Figure 3. The fuse with a rating not greater than 6A is recommended. The user can select a lower rating fuse based upon the highest inrush transient at the maximum input voltage and the maximum input current of the converter, which occurs at the minimum input voltage. Both input traces and the chassis ground trace (if applicable) must be capable of conducting a current of 1.5 times the value of the fuse without opening. The fuse must not be placed in the grounded input line, if any.

In order for the output of the QLS08ZH converter to be considered as SELV (Safety Extra Low Voltage) or TNV-1, according to all IEC60950 based standards, one of the following requirements must be met in the system design:

- (i) If the voltage source feeding the module is SELV or TNV-2, the output of the converter may be grounded or ungrounded.
- (ii) If the voltage source feeding the module is ELV, the output of the converter may be considered SELV only if the output is grounded per the requirements of the standard.
- (iii) If the voltage source feeding the module is a Hazardous Voltage Secondary Circuit, the voltage source feeding the module must be provided with at least Basic insulation between the source to the converter and any hazardous voltages. The entire system, including the QLS08ZH converter, must pass a dielectric withstand test for Reinforced insulation. Design of this type of systems requires expert engineering and understanding of the overall safety requirements and should be performed by qualified personnel.

## 2.4 THERMAL CONSIDERATIONS

The QLS08ZH converter is designed for natural or forced convection cooling. The maximum allowable output current of the converter is determined by meeting the derating criteria for all components used in the converter. For example, the maximum semiconductor junction temperature is not allowed to exceed 120°C to ensure reliable long-term operation of the converter. Contact Power-One for the complete list of the derating criteria.

The graph in Figure 2 shows the maximum output current of the QLS08ZH converter at different ambient temperatures under both natural and forced (longitudinal airflow direction, from pin 1 to pin 3) convection.

For example, the QLS08ZH operating at 50°C can deliver up to 6.5A reliably with 200LFM forced air.

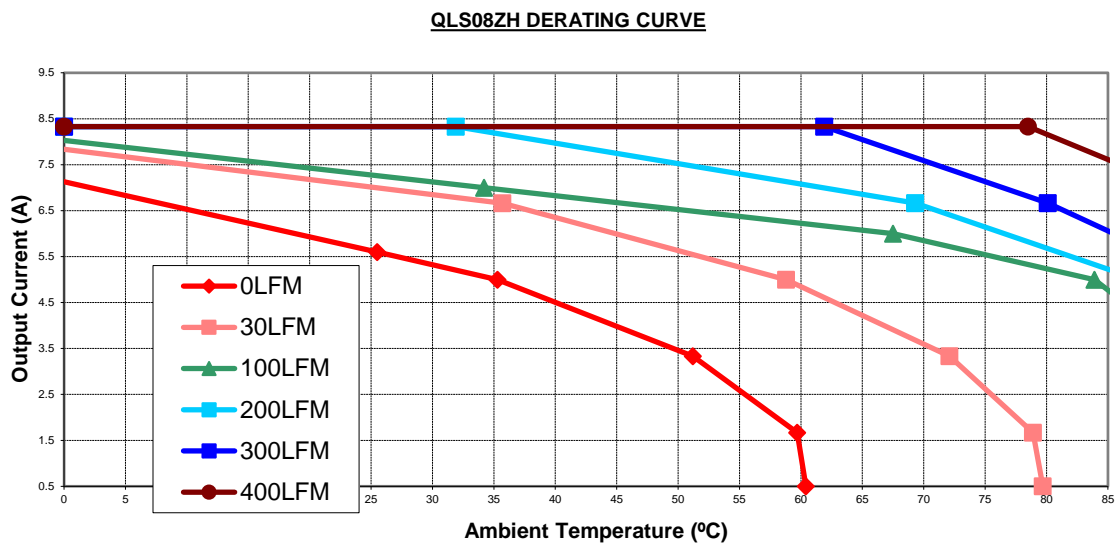

Figure 2. Derating Curves

# QLS08ZH

## 4. CHARACTERIZATION

### 3.1 TYPICAL APPLICATION

Figure 3. shows the recommended connections for the QLS08ZH converter.

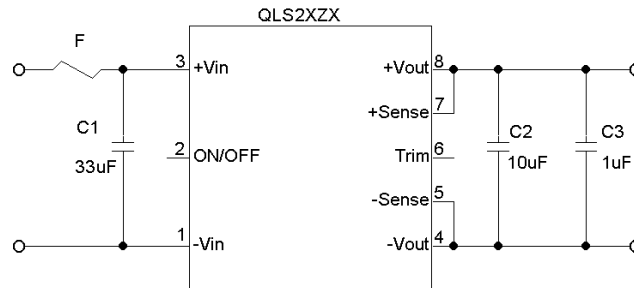

Figure 3. Typical Application of QLS08ZH

The QLS08ZH converter does not require any external components for proper operation. However, if the distribution of the input voltage to the converter contains significant inductance, the capacitor C1 may be required to enhance performance of the converter. A minimum of a 33µF electrolytic capacitor with the ESR<0.7Ω is recommended for the QLS08ZH.

Refer to the “Inrush Current Control Application Note” on [www.power-one.com](http://www.power-one.com) for suggestions on how to limit the magnitude of the inrush current.

For output decoupling we recommend using a 10µF tantalum and a 1µF ceramic capacitors connected directly across the output pins of the converter. Note, that the capacitors do not substitute the filtering required by the load.

### 3.2 SHUTDOWN FEATURE DESCRIPTION

The ON/OFF pin in the QLS08ZH converter functions as a normal soft shutdown. It is referenced to the -Vin pin (see Figure 1). With the positive logic, when the ON/OFF pin is pulled low, the output is turned off and the unit goes into a very low input power mode.

With negative logic, when the ON/OFF pin is pulled low, the unit is turned on.

An open collector switch is recommended to control the voltage between the ON/OFF pin and the -Vin pin of the converter. The ON/OFF pin is pulled up internally, so no external voltage source is required. The user should avoid connecting a resistor between the ON/OFF pin and the +Vin pin.

When the ON/OFF pin is used to achieve remote control, the user must take care to insure that the pin reference for the control is really the -Vin pin. The control signal must not be referenced ahead of EMI filtering, or remotely from the unit. Optically coupling the information and locating the optical coupler directly at the module will solve any of these problems.

#### NOTE:

If the ON/OFF pin is not used, it can be left floating (positive logic), or connected to the -Vin pin (negative logic).

### 3.3 CHARACTERISTIC CURVES

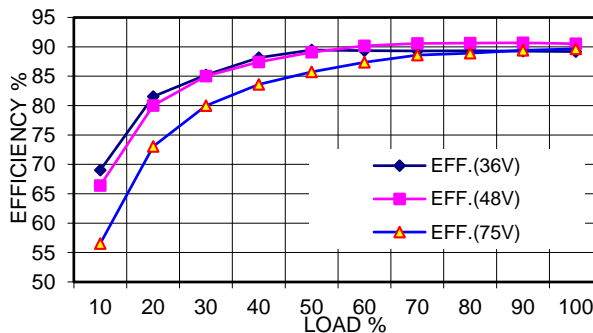

Figure 4. QLS08ZH Efficiency vs. Output Load

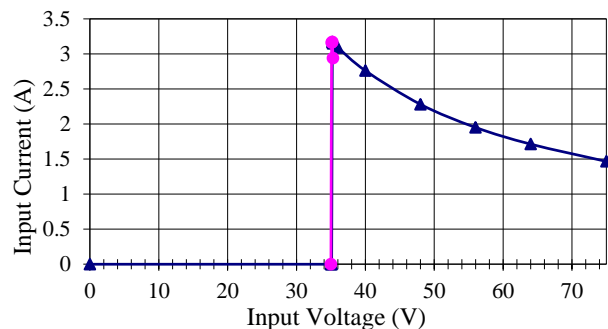
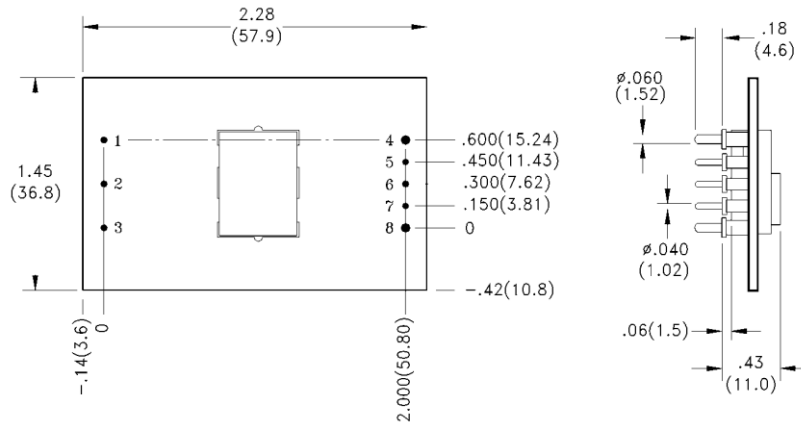

Figure 5. QLS08ZH Input Characteristics

# QLS08ZH

## 5. MECHANICAL PARAMETERS



PAD/PIN CONNECTIONS	
Pad/Pin #	Function
1	Vin (-)
2	ON/OFF
3	Vin (+)
4	Vout (-)
5	Sense (-)
6	TRIM
7	Sense (-)
8	Vout (+)

- Tolerances: .xx ± .020 (.5)  
.xxx ± .010 (.25)
- Pin Diameter ± 0.002 (.05)

## 6. ORDERING INFORMATION

OPTIONS	SUFFIXES TO ADD TO PART NUMBER
Remote ON/OFF	Positive- Standard, no suffix required
	Negative- Add "NT" suffix
Pin Length	0.18"- Standard, no suffix required
	0.145"- Add "7" suffix
	0.110"- Add "8" suffix

**Note:**

Consult factory for the complete list of available options

**For more information on these products consult: [tech.support@psbel.com](mailto:tech.support@psbel.com)**

**NUCLEAR AND MEDICAL APPLICATIONS** - Products are not designed or intended for use as critical components in life support systems, equipment used in hazardous environments, or nuclear control systems.

**TECHNICAL REVISIONS** - The appearance of products, including safety agency certifications pictured on labels, may change depending on the date manufactured. Specifications are subject to change without notice.

## Looking for pricing, stock, or lifecycle information?

Click below to explore more details on WIN SOURCE:

-  [View QLS08ZH-NT on WIN SOURCE](#)
-  [Bel Power Solutions Information](#)

## Optimize Your Supply Chain with WIN SOURCE Solutions

-  Global Sourcing Solution
-  Obsolete Management
-  Cost Control Management
-  Shortage Management
-  Alternative Solution
-  Excess Inventory Management