



THE DATASHEET OF QT1103-ISG



This datasheet is applicable to all revision 3 chips

The QT1103 is designed for low cost appliance, mobile, and consumer electronics applications.

QTouch™ technology is a type of patented charge-transfer sensing method well known for its robust, stable, EMC-resistant characteristics. It is the only all-digital capacitive sensing technology in the market today. This technology has over a decade of applications experience spanning thousands of designs.

QTouch circuits are renowned for simplicity, reliability, ease of design, and cost effectiveness.

QTouch™ sensors employ a single reference capacitor tied to two pins of the chip for each sensing key; a signal trace leads from one of the pins to the sensing electrode which forms the key. The sensing electrode can be a simple solid shape such as a rectangle or circle. An LED can be placed near or inside the solid circle for illumination.

The key electrodes can be designed into a conventional Printed Circuit Board (PCB) or Flexible Printed Circuit Board (FPCB) as a copper pattern, or as printed conductive ink on plastic film.

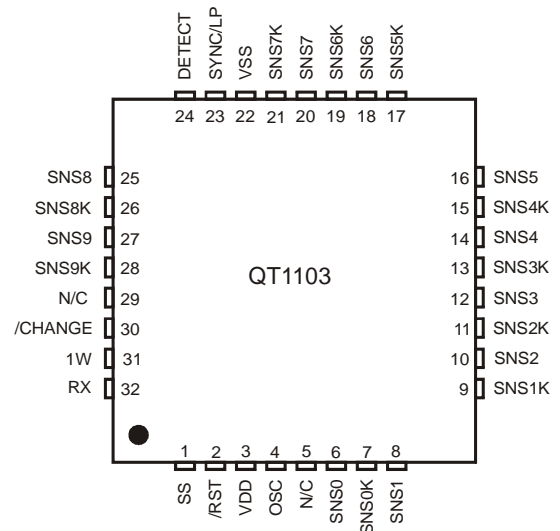

AT A GLANCE

Number of keys:	1 to 10
Technology:	Patented spread-spectrum charge-transfer (one-per-key mode)
Key outline sizes:	5mm x 5mm or larger (panel thickness dependent); widely different sizes and shapes possible
Key spacings:	6mm or wider, center to center (panel thickness, human factors dependent)
Electrode design:	Single solid or ring shaped electrodes; wide variety of possible layouts
Layers required:	One layer substrate; electrodes and components can be on same side
Substrates:	FR-4, low cost CEM-1 or FR-2 PCB materials; polyamide FPCB; PET films, glass
Electrode materials:	Copper, silver, carbon, ITO, Orgacon [†] ink (virtually anything electrically conductive)
Panel materials:	Plastic, glass, composites, painted surfaces (low particle density metallic paints possible)
Adjacent Metal:	Compatible with grounded metal immediately next to keys
Panel thickness:	Up to 50mm glass, 20mm plastic (key size dependent)
Key sensitivity:	Settable via change in reference capacitor (Cs) value
Outputs:	RS-232 based serial output, capable of single-wire operation
Moisture tolerance:	Good
Power:	2.8V ~ 5.0V
Package:	32-pin 5 x 5mm QFN RoHS compliant
Signal processing:	Self-calibration, auto drift compensation, noise filtering, AKS™
Applications:	Portable devices, domestic appliances and A/V gear, PC peripherals, office equipment
Patents:	AKS™ (patented Adjacent Key Suppression) QTouch™ (patented Charge-transfer method)

[†]Orgacon is a registered trademark of Agfa-Gevaert N.V

AVAILABLE OPTIONS

T_A	32-QFN
-40°C to +85°C	QT1103-ISG

Contents

1 Overview	3
1.1 Differences With QT1101	3
1.2 Parameters	3
1.2.1 Introduction	3
1.2.2 Burst Operation	3
1.2.3 Self-calibration	3
1.2.4 Autorecalibration	3
1.2.5 Drift Compensation	3
1.2.6 Detection Integrator Confirmation	3
1.2.7 Spread-spectrum Operation	3
1.2.8 Sync Mode	3
1.2.9 Low Power (LP) Mode	3
1.2.10 Adjacent Key Suppression (AKS™)	4
1.2.11 Outputs	4
1.2.12 Simplified Mode	4
1.3 Wiring	5
2 Device Operation	8
2.1 Reset and Startup Time	8
2.2 Option Resistors	8
2.3 DETECT Pin	8
2.4 /CHANGE Pin	8
2.5 SYNC/LP Pin	8
2.5.1 Introduction	8
2.5.2 Sync Mode	8
2.5.3 Low Power (LP) Mode	8
2.6 AKS™ Function Pins	9
2.7 MOD_0, MOD_1 Inputs	9
2.8 Fast Detect Mode	9
2.9 Simplified Mode	10
2.10 Unused Keys	10
2.11 Serial 1W Interface	10
2.11.1 Introduction	10
2.11.2 Basic 1W Operation	10
2.11.3 LP Mode Effects on 1W	11
2.11.4 2W Operation	11
3 Design Notes	11
3.1 Oscillator Frequency	11
3.2 Spread-spectrum Circuit	12
3.3 Cs Sample Capacitors - Sensitivity	12
3.4 Rsns Resistors	12
3.5 Power Supply	12
3.6 PCB Layout and Construction	12
4 Specifications	13
4.1 Absolute Maximum Specifications	13
4.2 Recommended Operating Conditions	13
4.3 AC Specifications	13
4.4 DC Specifications	13
4.5 Signal Processing	14
4.6 Idd Curves	15
4.7 LP Mode Typical Response Times	18
4.8 Mechanical Dimensions	19
4.9 Part Marking	20
4.10 Moisture Sensitivity Level (MSL)	20
5 Datasheet Control	21
5.1 Changes	21
5.2 Numbering Convention	21

1 Overview

1.1 Differences With QT1101

The QT1103 is a general replacement device for the highly popular QT1101. It has all of the same features as the older device but differs in the following ways:

- Rs resistors on each channel eliminated
- Up to 4x more sensitive for a given value of Cs
- Shorter burst lengths, less power for a given value of Cs
- 'Burst A and B' only mode for up to eight keys, with less power
- 'Burst B' only mode for up to four keys, with less power than 'Burst A and B' mode
- Requires an external reset signal

The QT1103 should be used instead of the QT1101 for new designs due to a simpler circuit, lower power and lower cost.

1.2 Parameters

1.2.1 Introduction

The QT1103 is an easy to use, ten touch-key sensor IC based on Quantum's patented charge-transfer ('QT') principles for robust operation and ease of design. This device has many advanced features which provide for reliable, trouble-free operation over the life of the product.

1.2.2 Burst Operation

The device operates in 'burst mode'. Each key is acquired using a burst of charge-transfer sensing pulses whose count varies depending on the value of the reference capacitor Cs and the load capacitance Cx. In LP mode, the device sleeps in an ultra-low current state between bursts to conserve power. The keys signals are acquired using three successive bursts of pulses:

Burst A: Keys 0, 1, 4, 5
Burst B: Keys 2, 3, 6, 7
Burst C: Keys 8, 9

Bursts always operate in C-A-B sequence.

1.2.3 Self-calibration

On power-up, all ten keys are self-calibrated within 300ms (typical) to provide reliable operation under almost any conditions.

1.2.4 Autorecalibration

The device can time out and recalibrate each key independently after a fixed interval of continuous touch detection, so that the keys can never become 'stuck on' due to foreign objects or other sudden influences. After recalibration the key will continue to function normally. The delay is selectable to be either 10s, 60s, or infinite (disabled).

The device also autorecalibrates a key when its signal reflects a sufficient decrease in capacitance. In this case the device recalibrates after ~2 seconds so as to recover normal operation quickly.

1.2.5 Drift Compensation

Drift compensation operates to correct the reference level of each key slowly but automatically over time, to suppress false detections caused by changes in temperature, humidity, dirt and other environmental effects.

1.2.6 Detection Integrator Confirmation

Detection Integrator (DI) confirmation reduces the effects of noise on the QT1103. The DI mechanism requires consecutive detections over a number of measurement bursts for a touch to be confirmed and indicated on the outputs. In a like manner, the end of a touch (loss of signal) has to be confirmed over a number of measurement bursts. This process acts as a type of 'debounce' against noise.

A per-key counter is incremented each time the key has exceeded its threshold and stayed there for a number of measurement bursts. When this counter reaches a preset limit the key is finally declared to be touched.

For example, if the limit value is six, then the device has to exceed its threshold and stay there for six measurement bursts in succession without going below the threshold level, before the key is declared to be touched. If on any measurement burst the signal is not seen to exceed the threshold level, the counter is cleared and the process has to start from the beginning.

In normal operation, the start of a touch must be confirmed for six measurement bursts and the end of a touch for three. In a special 'Fast Detect' mode (available via jumper resistors) (Tables 1.2 and 1.6), confirmation of the start of a touch requires only three and the end of a touch requires two measurement bursts.

Fast detect is only available when AKS is disabled.

1.2.7 Spread-spectrum Operation

The bursts operate over a spread of frequencies, so that external fields will have minimal effect on key operation and emissions are very weak. Spread spectrum operation works with the DI mechanism to dramatically reduce the probability of false detection due to noise.

1.2.8 Sync Mode

The QT1103 features a Sync mode to allow the device to slave to an external signal source, such as a mains signal (50/60Hz), to limit interference effects. This is performed using the SYNC/LP pin. Sync mode operates by triggering three sequential acquire bursts, in sequence C-A-B from the Sync signal. Thus, each Sync pulse causes all ten keys to be acquired (see Section 2.5.2, page 8).

1.2.9 Low Power (LP) Mode

The device features an LP mode for microamp levels of current drain with a slower response time, to allow use in battery operated devices. On detection of touch, the device automatically reverts to its normal mode and asserts the DETECT pin active to wake up a host controller. The device remains in normal, full acquire speed mode until another pulse is seen on its SYNC/LP pin, upon which it goes back to LP mode (see **Optimization of LP Mode**, page 9).

When eight or fewer keys are required, current drain in LP mode can be further reduced by choosing appropriate channels on the QT1103 (see the end of Section 2.5.3, page 8).

1.2.10 Adjacent Key Suppression (AKS™)

AKS™ is a Quantum-patented feature that can be enabled via a resistor strap option. AKS works to prevent multiple keys from responding to a single touch, a common complaint about capacitive touch panels. This can happen with closely spaced keys, or with control surfaces that have water films on them.

AKS operates by comparing signal strengths from keys within a group of keys to suppress touch detections from those that have a weaker signal change than the dominant one.

The QT1103 has two different AKS groupings of keys, selectable via option resistors. These groupings are:

- AKS operates in three groups of keys
- AKS operates over all ten keys

These two modes allow the designer to provide AKS while also providing for shift or function operations.

If AKS is disabled, all keys can operate simultaneously.

1.2.11 Outputs

The QT1103 has a serial output using one or two wires, RS-232 data format, and automatic baud rate detection. A simple protocol is employed.

The QT1103 operates in slave mode, i.e. it only sends data to the host after receiving a request from the host.

An additional /CHANGE (state changed) signal allows the use of the serial interface to be optimised, rather than being polled continuously.

1.2.12 Simplified Mode

To reduce the need for option resistors, the simplified operating mode places the part into fixed settings with only the AKS feature being selectable. LP mode is also possible in this configuration. Simplified mode is suitable for most applications.

1.3 Wiring

Table 1.1 Pin Descriptions

Pin	Name	Type	Function	Notes	If Unused
1	SS	OD	Spread spectrum	Spread spectrum drive	100kΩ resistor to Vss
2	/RST	I	Reset input	Active low reset	-
3	Vdd	P	Power	+2.8 ~ +5.0V	-
4	OSC	I	Oscillator	Resistor to Vdd and optional spread spectrum RC network	-
5	n/c	-	-	Leave open	-
6	SNS0	I/O	Sense pin and option select	To Cs0 and/or option resistor	Open or option resistor*
7	SNS0K	I/O	Sense pin	To Cs0 + Key	Open
8	SNS1	I/O	Sense pin and option select	To Cs1 and/or option resistor*	Open or option resistor*
9	SNS1K	I/O	Sense pin	To Cs1 + Key	Open
10	SNS2	I/O	Sense pin and option select	To Cs2 and/or option resistor*	Open or option resistor*
11	SNS2K	I/O	Sense pin	To Cs2 + Key	Open
12	SNS3	I/O	Sense pin and option select	To Cs3 and/or option resistor*	Open or option resistor*
13	SNS3K	I/O	Sense pin	To Cs3 + Key	Open
14	SNS4	I/O	Sense pin	To Cs4	Open
15	SNS4K	I/O	Sense pin	To Cs4 + Key	Open
16	SNS5	I/O	Sense pin and option select	To Cs5 and/or option resistor *	Open or option resistor*
17	SNS5K	I/O	Sense pin	To Cs5 + Key	Open
18	SNS6	I/O	Sense pin and option select	To Cs6 and/or option resistor*	Open or option resistor*
19	SNS6K	I/O	Sense pin and mode select	To Cs6 + Key and/or mode resistor†	Open or mode resistor†
20	SNS7	I/O	Sense pin and mode or option select	To Cs7 and/or mode resistor† or option resistor*	Open or mode resistor† or option resistor*
21	SNS7K	I/O	Sense pin	To Cs7 + Key	Open
22	Vss	P	Ground	0V	-
23	SYNC/LP‡	I	Sync In or LP In	Rising edge sync or LP pulse	Vdd or Vss**
24	DETECT	O/OD	Detect Status	See Table 1.4	Open
25	SNS8	I/O	Sense pin	To Cs8	Open
26	SNS8K	I/O	Sense pin	To Cs8 + Key	Open
27	SNS9	I/O	Sense pin	To Cs9	Open
28	SNS9K	I/O	Sense pin	To Cs9 + Key	Open
29	n/c	-	-	-	Open
30	/CHANGE	OD	State changed	0 = a key state has changed Requires pull-up	100kΩ resistor to Vss
31	1W	I/OD	1W mode serial I/O	Requires pull-up to Vdd	-
32	RX	I	2W Receive	Input for 2W mode	Vdd

Pin Type

I	CMOS input only
I/O	CMOS I/O
OD	CMOS open drain output
I/OD	CMOS input or open drain output
O/OD	CMOS push-pull or open-drain output (option selected)
P	Ground or power

Notes

- † Mode resistor is required only in Simplified mode (see Figure 1.2)
- * Option resistor is required only in Full Options mode (see Figure 1.1)
- ‡ Pin is either Sync or LP depending on options selected (functions SL_0, SL_1, see Figure 1.1)
- ** See text

Figure 1.1 Connection Diagram - Full Options (32-QFN Package)

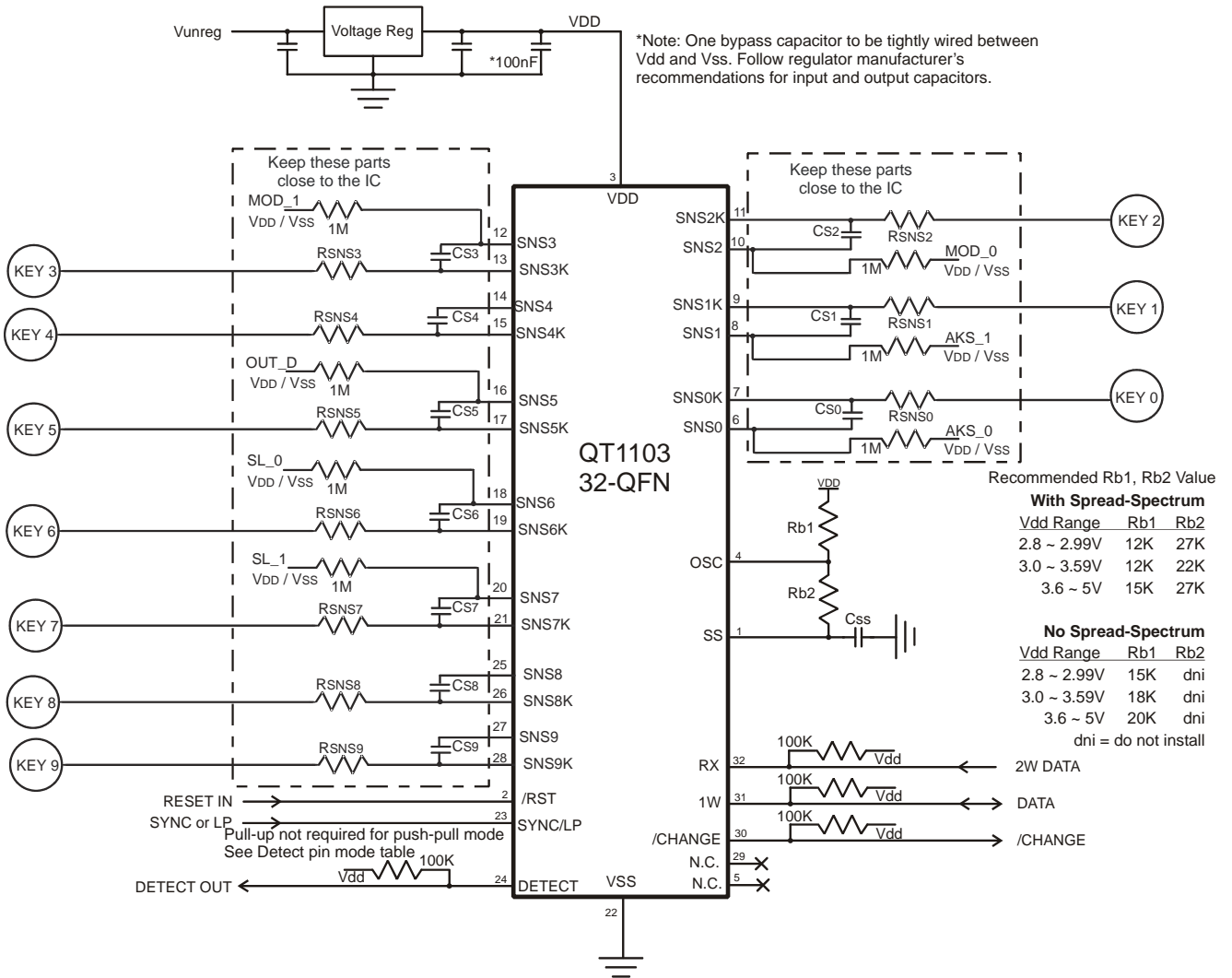

Table 1.2
AKS / Fast-Detect Options

AKS_1	AKS_0	AKS MODE	FAST-DETECT
Vss	Vss	Off	Off
Vss	Vdd	Off	Enabled
Vdd	Vss	On, in 3 groups	Off
Vdd	Vdd	On, global	Off

Table 1.3
Max On-Duration

MOD_1	MOD_0	MAX ON-DURATION MODE
Vss	Vss	10 seconds to recalibrate
Vss	Vdd	60 seconds to recalibrate
Vdd	Vss	Infinite (disabled)
Vdd	Vdd	(reserved)

Table 1.4
Detect Pin Drive

OUT_D	DETECT PIN MODE
Vss	Open drain, active low
Vdd	Push-pull, active high

Table 1.5
SYNC/LP Function

SL_1	SL_0	SYNC/LP PIN MODE
Vss	Vss	Sync
Vss	Vdd	LP mode: 70ms response time
Vdd	Vss	LP mode: 110ms response time
Vdd	Vdd	LP mode: 190ms response time

Figure 1.2 Connection Diagram - Simplified Mode (32-QFN Package)

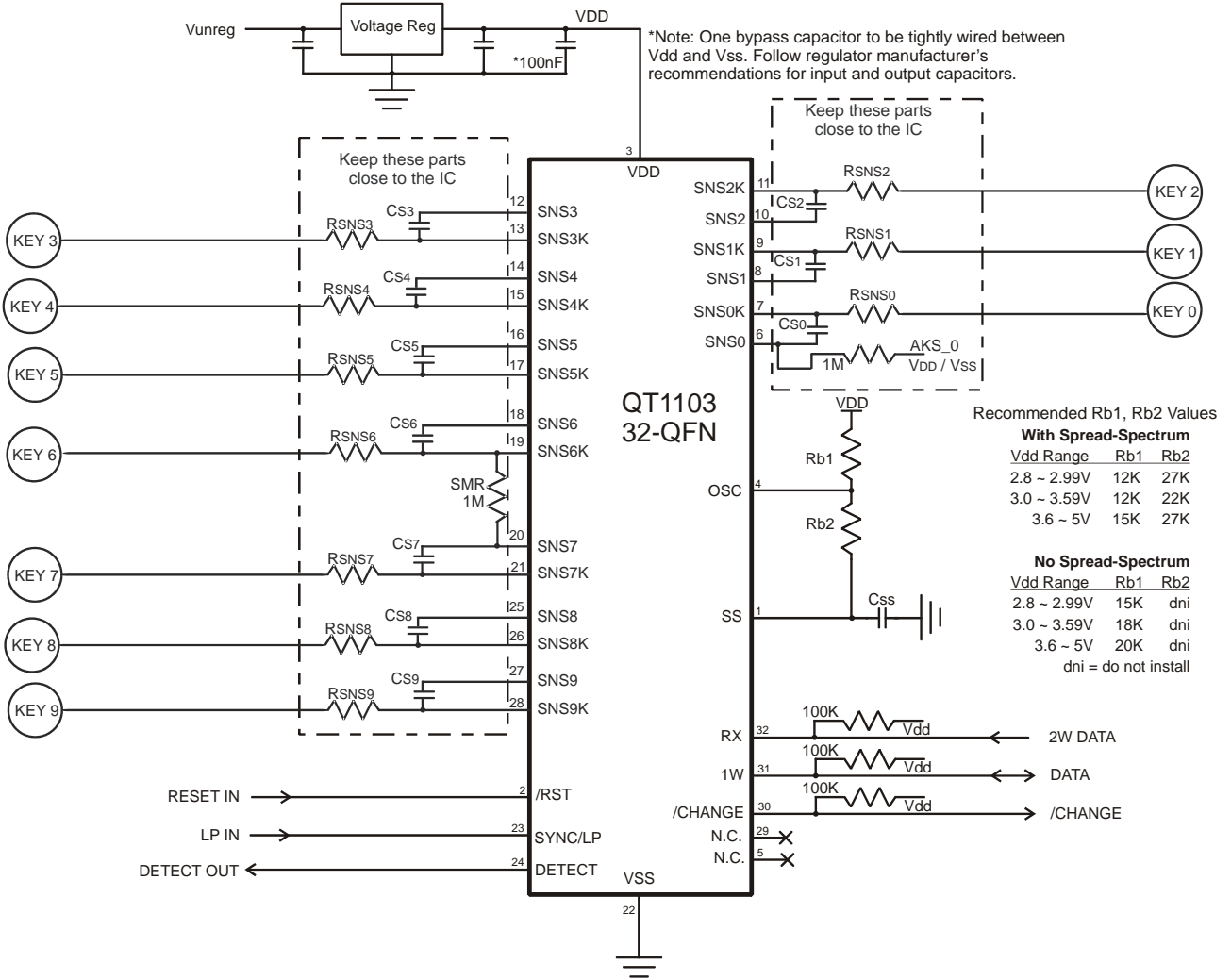

**Table 1.6
AKS Resistor Options**

AKS_0	AKS MODE	FAST-DETECT
Vss	Off	Enabled
Vdd	On, global	Off

**Table 1.7
Functions in Simplified Mode**

SYNC/LP pin	110ms LP function; sync not available
Max on-duration delay	60 seconds
Detect Pin	Push-pull, active high

Suggested regulator manufacturers:

- Toko (XC6215 series)
- Seiko (S817 series)
- BCDSemi (AP2121 series)

Re Figures 1.1 and 1.2 check the following sections for the variable component values:

- Section 3.3, page 12: Cs capacitors (Cs)
- Section 3.4, page 12: Sample resistors (RSNS)
- Section 3.5, page 12: Voltage levels
- Section 3.2, page 12: C_{ss} capacitor

2 Device Operation

2.1 Reset and Startup Time

After a reset event, the device typically requires 260ms to initialize, calibrate, and start operating normally. Keys will work properly once all keys have been calibrated after reset.

The QT1103 does not have a brownout detector; its reset input must be taken active (low) following power-up and when Vdd falls below 2V.

2.2 Option Resistors

The option resistors are read on power-up only. There are two primary option mode configurations: full, and simplified.

Full options mode: Seven 1MΩ option resistors are required as shown in Figure 1.1. All seven resistors are mandatory.

Simplified mode: A 1MΩ resistor should be connected from SNS6K to SNS7. In simplified mode, only one additional 1MΩ option resistor is required for the AKS feature (Figure 1.2).

Note that the presence and connection of option resistors will influence the required values of Cs; this effect will be especially noticeable if the Cs values are under 22nF. Cs values should be adjusted for optimal sensitivity after the option resistors are connected.

2.3 DETECT Pin

DETECT represents the functional logical-OR of all ten keys. DETECT can be used to wake a battery-operated product upon human touch.

The output polarity and drive of DETECT are governed according to Table 1.4, page 6, and Table 1.7, page 7.

2.4 /CHANGE Pin

The /CHANGE pin can be used to tell the host that a change in touch state has been detected (i.e. a key has been touched or released), and that the host should read the new key states over the serial interface. /CHANGE is pulled low when a key state change has occurred.

/CHANGE is very useful to prevent transmissions with duplicate data. If /CHANGE is not used, the host would need to keep polling the QT1103 constantly, even if there are no changes in touch. Upon detection of a key, /CHANGE will pull low and stay low until the serial interface has been polled by the host. /CHANGE will then be released and return high until the next change of key state, either on or off, on any key (Figures 2.6, 2.9).

The /CHANGE pin is open-drain, and requires a ~100k pull-up resistor to Vdd in order to function properly.

2.5 SYNC/LP Pin

2.5.1 Introduction

The SYNC / LP pin function is configured according to the SL_0 and SL_1 resistor connections to either Vdd or Vss (see Table 1.5).

2.5.2 Sync Mode

Sync mode allows the designer to synchronize acquire bursts to an external signal source, such as mains frequency (50/60Hz), to suppress interference. It can also be used to synchronize two QT parts which operate near each other, so that they will not cross-interfere if two or more of the keys (or associated wiring) of the two parts are near each other.

The SYNC input is positive pulse triggered. Following each rising edge the device will generate three acquire bursts in C-A-B sequence.

Figure 2.1 Acquire Bursts in C-A-B Sequence

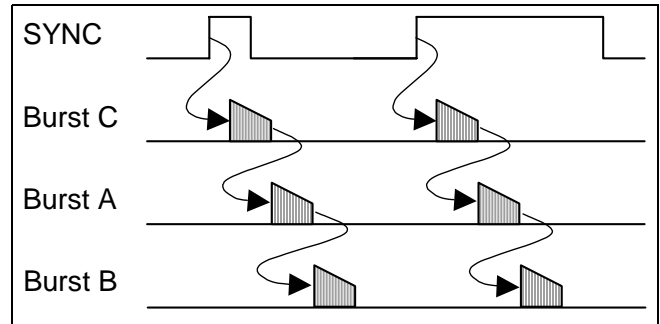

If the SYNC input does not change level for ~150ms, the QT1103 will free-run, generating a continuous stream of acquire bursts C-A-B-C-A-B-C-A... . While the QT1103 is in free-run operation, a rising edge on the SYNC input will return the QT1103 to synchronised operation.

Note that the SYNC input must remain at one level (high or low) for >150μs to guarantee that the QT1103 will recognise that level.

2.5.3 Low Power (LP) Mode

LP mode allows the device to be switched between full speed operation (14ms (normal mode) or 28ms (fast mode) typical response time and normal power consumption), and Low Power operation (low average power consumption but an increased maximum response time) according to the needs of the application. There are three maximum response time settings for low power operation: 70ms, 110ms, and 190ms nominal; the response time setting is determined by option resistors SL_1 and SL_0 (see Table 1.5). Slower response times result in a lower average power drain.

Operation in low power mode is governed by the state of the LP input and whether at least one key has a confirmed touch.

If the LP input is at a constant low level, then the QT1103 will remain in full speed operation (14ms or 28ms typical response time and normal power consumption), as in Figure 2.2.

Figure 2.2 Full Speed Operation

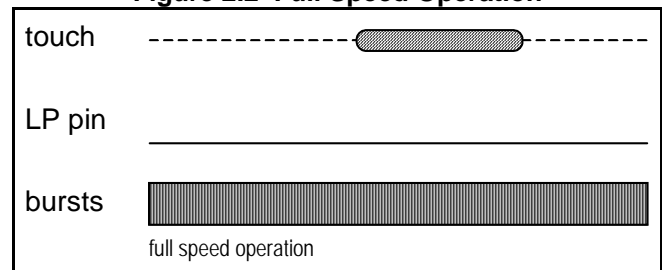

If the LP input is at a constant high level, then the QT1103 will enter low power operation whenever it is not detecting a touch. It will switch automatically to full speed operation while there is a touch, and revert to low power operation at the end of the touch. This is shown in Figure 2.3.

Figure 2.3 Low Power/Full Speed Operation

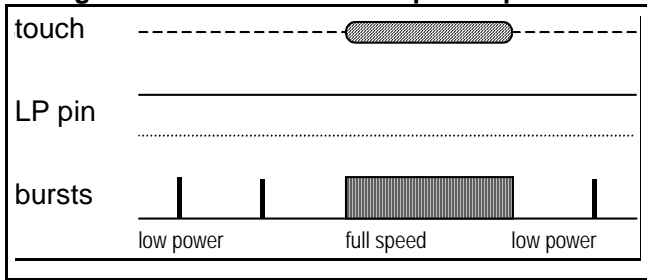

While there is no touch, if the LP input is driven high then low, the QT1103 will enter low power operation, as described previously, and remain in low power operation when LP is taken low. When there is a touch the QT1103 will switch automatically to full speed operation. At the end of the touch the choice of operation depends on the state of the LP input. This is shown in Figures 2.4 and 2.5 - the first with the LP pin being low at the end of the touch, and the second with the LP pin being high at the end of the touch.

Figure 2.4 LP Pin Low at End of Touch

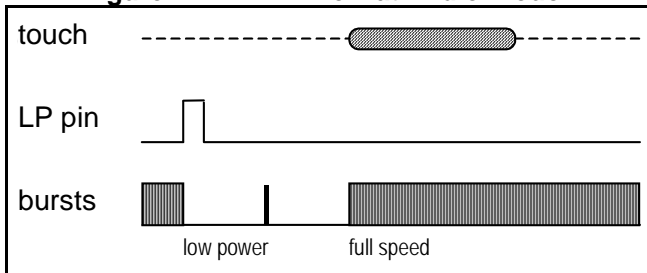
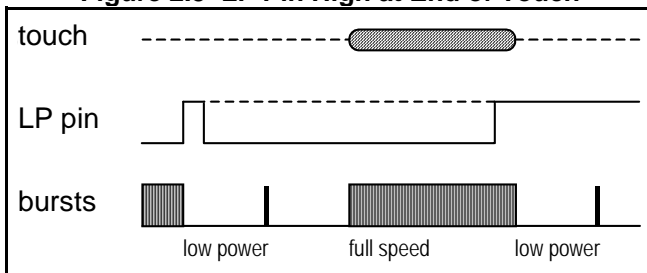

Figure 2.5 LP Pin High at End of Touch



Note that the LP input must remain at one level (high or low) for >150µs to guarantee that the QT1103 will recognise that level.

Optimization of LP Mode

For low power consumption, when up to eight keys are required, all keys should be connected to QT1103 channels that are measured during acquire bursts A and B (i.e. K0...K7).

For the lowest possible power consumption, when up to four keys are required, all keys should be connected to QT1103 channels that are measured during acquire burst B (i.e. K2, K3, K6, K7).

If this is done the QT1103 automatically selects an optimized LP operation, which gives a significantly lower power consumption than would be achieved if additional acquire bursts were used.

Optimized LP operation is identical to the standard LP operation in all other ways; it is controlled as described previously.

2.6 AKS™ Function Pins

The QT1103 features an adjacent key suppression (AKS™) function with two modes. Option resistors act to set this feature according to Tables 1.2 and 1.6. AKS can be disabled, allowing any combination of keys to become active at the same time. When operating, the modes are:

Global: The AKS function operates across all ten keys. This means that only one key can be active at any one time.

Groups: The AKS function operates among three groups of keys: 0-1-4-5, 2-3-6-7, and 8-9. This means that up to three keys can be active at any one time.

In Group mode, keys in one group have no AKS interaction with keys in any other group.

Note that in Fast Detect mode, AKS can only be off.

2.7 MOD_0, MOD_1 Inputs

In full option mode, the MOD_0 and MOD_1 resistors are used to set the 'Max On-Duration' recalibration timeouts. If a key becomes stuck on for a lengthy duration of time, this feature will cause an automatic recalibration event of that specific key only once the specified on-time has been exceeded. Settings of 10s, 60s, and infinite are available.

The Max On-Duration feature operates on a key-by-key basis; when one key is stuck on, its recalibration has no effect on other keys.

The logic combination on the MOD option pins sets the timeout delay; see Table 1.3.

Simplified mode MOD timing: In simplified mode, the max on-duration is fixed at 60s.

2.8 Fast Detect Mode

In many applications, it is desirable to sense touch at high speed. Examples include scrolling 'slider' strips or 'Off' buttons. It is possible to place the device into a 'Fast Detect' mode that usually requires under 14ms (typical) to respond. This is accomplished internally by setting the Detect Integrator to only three counts, i.e. only three successive detections are required to detect touch.

In LP mode, 'Fast' detection will not speed up the initial delay (which could be up to 190ms typical depending on the option setting). However, once a key is detected the device is forced back into normal speed mode. It will remain in this faster mode until requested to return to LP mode.

When used in a 'slider' application, it is normally desirable to run the keys without AKS.

In Fast mode the time required to process a key release is reduced from three samples to two. Fast Detect mode can be enabled as shown in Tables 1.2 and 1.6.

2.9 Simplified Mode

A simplified operating mode which does not require the majority of option resistors is available. This mode is set by connecting a resistor labeled SMR between pins SNS6K and SNS7 (see Figure 1.2).

In this mode there is only one option available - AKS enable or disable. When AKS is disabled, Fast Detect mode is enabled; when AKS is enabled, Fast Detect mode is off.

AKS in this mode is global only (i.e. operates across all functioning keys).

The other option features are fixed as follows:

DETECT Pin: Push-pull, active high

SYNC/LP Function: LP mode, ~110ms response time

Max On-Duration: 60 seconds

See also Tables 1.6 and 1.7.

2.10 Unused Keys

Unused keys should be disabled by removing the corresponding Cs and Rsns components and connecting SNS pins as shown in the 'Unused' column of Table 1.1. Unused keys are ignored and do not factor into the AKS function (Section 2.6).

2.11 Serial 1W Interface

2.11.1 Introduction

The 1W serial interface is an RS-232 based auto baud rate serial asynchronous interface that requires only one wire between the host MCU and the QT1103. The serial data are extremely short and simple to interpret.

Auto baud rate detection takes place by having the host device send a specific character to the QT1103, which allows the QT1103 to set its baud rate to match that of the host.

One feature of this method is that the baud rate can be any rate between 8,000 and 38,400 bits per second. Neither the QT1103 nor the host device has to be accurate in their transmission rates, i.e. crystal control is not required.

Depending on the timing of a 1W host transmission, the QT1103 device may need to abort an acquisition burst, and rerun it after the transmission is complete and a reply has been sent. As a consequence, each host request can potentially result in a small, unnoticeable increase in detection delay.

1W Connection: The 1W pin should be pulled high with a resistor. When not in use it floats high, hence this causes no increase in supply current.

During transmission from the host, the host may drive the 1W line with either an open-drain or a push-pull driver. However, if the host uses push-pull driving, it must release the 1W line as soon as it is done with its stop bit so that there is no drive conflict when the QT1103 sends its reply.

If open-drain transmission is used by the host, the value of the pull-up resistor should be optimized for the desired baud rate: faster rates require a lower value of resistor to prevent rise-time problems. A typical value for 19,200 baud might be 100kΩ. An oscilloscope should be used to confirm that the resistor is not causing excessive timing skew that might cause bit errors.

The QT1103 uses push-pull drive to transmit data out on the 1W line back to the host. When the stop bit level is established, 1W is floated; for this reason, a pull-up resistor should always be used on the 1W pin to prevent the signal from drifting to an undefined state. A 100kΩ pull-up resistor on 1W is recommended, unless the host uses open-drain drive to the QT1103, in which case a lower value may be required (see prior paragraph).

2.11.2 Basic 1W Operation

The basic sequence of 1W serial operation is shown in Figure 2.6. The 1W line is bi-directional and must be pulled high with a resistor to prevent a floating, undefined state (see Section 2.11.1).

Oscillator Tolerance: While the auto baud rate detection mechanism has a wide tolerance for oscillator error, the QT's oscillator should still not vary by more than ±20 percent from the recommended value. Beyond a ±20 percent error, communications at either the lower or upper stated limits could fail. The oscillator frequency can be checked with an oscilloscope by probing the pulse width on the SNS lines (see Section 3.1, page 11).

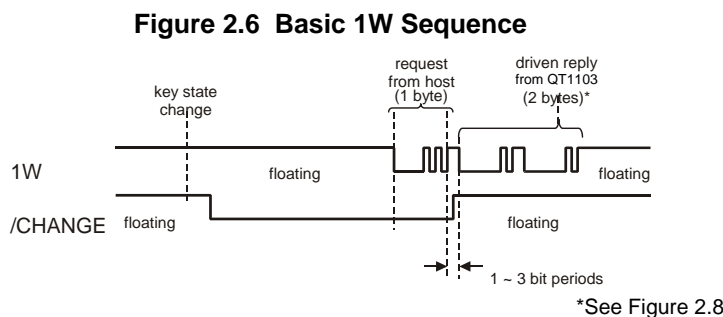

Host Request Byte: The host requests the key state from the QT1103 by sending an ASCII "P" character (ASCII decimal code 80, hex 0x50) over the 1W line. The character is formatted according to conventional RS-232:

8 data bits
no parity
1 stop bit
baud rate: 8,000 - 38,400

Figure 2.7 shows the bit pattern of the host request byte ('P'). The first bit labeled 'S' is the start bit, the last 'S' is the stop bit. This bit pattern should never be changed. The QT1103 will respond at the same baud rate as the received 'P' character.

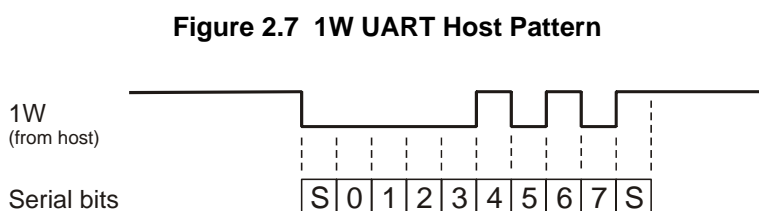

After sending the 'P' character the host must immediately float the 1W signal to prevent a drive conflict between the host and the QT1103 (see Figure 2.6). The delay from the received stop bit to the QT1103 driving the 1W pin is in the range 1-3 bit periods, so the host should float the pin within one bit period to prevent a drive conflict.

Figure 2.8 UART Response Pattern on 1W Pin

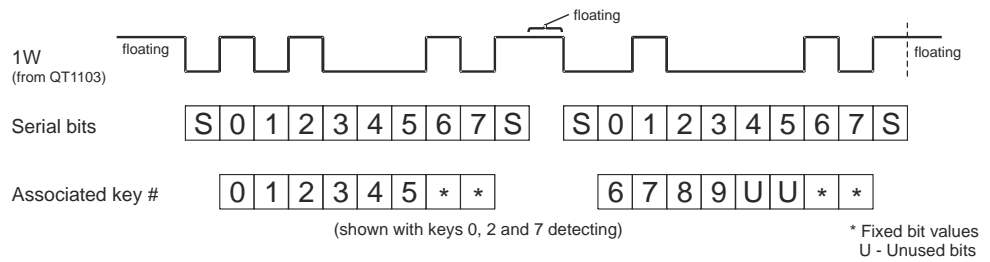

Data Reply: Before sending a reply, the QT1103 returns the /CHANGE signal to its inactive (float-high) state.

The QT1103 then replies by sending two eight-bit characters to the host over the 1W line using the same baud rate as the request. With no keys pressed, both reply bytes are ASCII '@' (0x40) characters; any keys that are pressed at the time of the reply result in their associated bits being set in the reply. Figure 2.8 shows the reply bytes when keys 0, 2 and 7 are pressed - 0x45, 0x42, and the associations between keys and bits in the reply.

The QT1103 floats the 1W pin again after establishing the level of the stop bit.

2.11.3 LP Mode Effects on 1W

The use of low power (LP) mode presents some additional 1W timing requirements. In LP mode (Section 2.5), the QT1103 will only respond to a request from the host when it is making one of its infrequent checks for a key press. Hence, in that condition most requests from the host to the QT1103 will be ignored, since the QT1103 will be sleeping and unresponsive. However, if either /CHANGE or DETECT are active the QT1103 will be at full speed, and hence will always respond to 'P' requests.

Note that when sleeping in LP mode, there are by definition no keys active, so there should not be a reason for the host to send the 'P' query command in the first place.

Three strategies are available to the host to ensure that LP mode operates correctly:

- **/CHANGE used.** The host monitors /CHANGE, and only sends a 'P' request when it is low. The part is awake by definition when /CHANGE is low. If /CHANGE is high, key states are known to be unchanged since the last reply received from the QT1103, and so additional 'P' requests are not needed. Before triggering LP mode the host should wait for /CHANGE to go high after all keys have become inactive.
- **DETECT used.** The host monitors DETECT, and if it is active (i.e. the part is awake) it polls the device regularly to obtain key status. When DETECT is inactive (the part may be sleeping) no requests are sent because it is known that no keys are active. Before triggering LP mode the host should wait for DETECT to become inactive, and then send one additional 'P' request to ensure /CHANGE is also made inactive.

- **Neither /CHANGE nor DETECT used.** The host polls the device regularly to obtain key status, with a timeout in operation when awaiting the reply to each 'P' request. Not receiving a reply within the timeout period only occurs when the part is sleeping, and hence when no keys are active. Before triggering LP mode the host should wait for all keys to become inactive and then send an additional 'P' request to the QT1103 to ensure /CHANGE is also inactive.

2.11.4 2W Operation

1W operation, as described in Section 2.11.3, requires that the host float the 1W line while awaiting a reply from the QT1103; this is not always possible.

To solve this problem, the QT1103 can also receive the 'P' character from the host on its 'Rx' pin separately from the 1W pin (Figure 2.9). The host need not float the Rx line since the QT1103 will never try to drive it.

Following a 'P' on Rx, the QT1103 will send the same response pattern (Figure 2.8) over the 1W line as in pure 1W mode.

All other comments and timings given for 1W operation are applicable for 2W operation. LP operation is the same for 2W mode as for 1W.

If the Rx pin is not used, it must be tied to Vdd.

3 Design Notes

3.1 Oscillator Frequency

The QT1103's internal oscillator runs from an external network connected to the OSC and SS pins as shown in Figures 1.1 and 1.2. The charts in these figures show the recommended values to use depending on nominal operating voltage and spread spectrum mode.

If spread spectrum mode is not used, only resistor Rb1 should be used, the C_{ss} capacitor eliminated, and the SS pin pulled to V_{ss} with a 100k resistor.

Figure 2.9 2W Operation

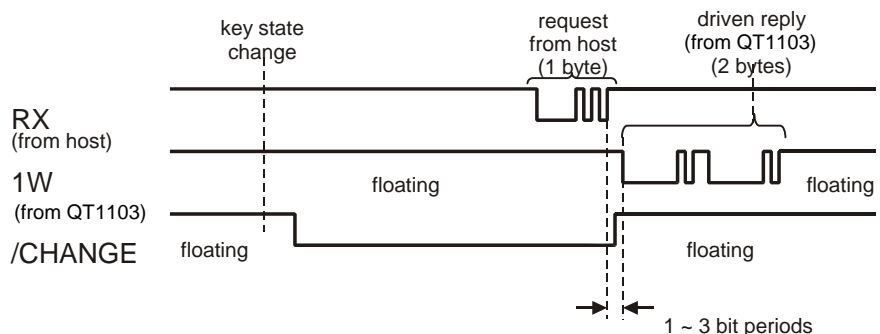

An out-of-spec oscillator can induce timing problems such as large variations in Max On-Duration times and response times as well as the serial port baud rate range.

Effect on serial communications: The oscillator frequency has no nominal effect on serial communications since the baud rate is set by an auto-sensing mechanism. However, if the oscillator is too far outside the recommended settings, the possible range of serial communications will shrink. For example, if the oscillator is too slow, the upper baud rate will be reduced.

The oscillator frequency can be verified by measuring the burst pulses at the start of a burst.

- In spread-spectrum mode, the first pulses of a burst should ideally be 2.87 μ s
- In non spread-spectrum mode, the target value is 2.67 μ s

If in doubt, make the pulses on the narrower side (i.e. a faster oscillator) when using the higher baud rates, and conversely on the wider side when using the lowest baud rates.

3.2 Spread-spectrum Circuit

The QT1103 offers the ability to spectrally spread its frequency of operation to heavily reduce susceptibility to external noise sources and to limit RF emissions. The SS pin is used to modulate an external passive RC network that modulates the OSC pin. OSC is the main oscillator current input. The circuits and recommended values are shown in Figures 1.1 and 1.2.

The resistors Rb1 and Rb2 should be changed depending on Vdd. As shown in Figures 1.1 and 1.2, three sets of values are recommended for these resistors depending on Vdd. The power curves in Section 4.6 also show the effect of these resistors.

The circuit can be eliminated, if it is not desired, by using a resistor from OSC to VDD to drive the oscillator, and connecting SS to Vss with a 100k Ω resistor (see Section 3.1).

The spread-spectrum RC network might need to be modified slightly with longer burst lengths. The sawtooth waveform observed on SS should reach a crest height as follows:

- Vdd \geq 3.6V: 17 percent of Vdd
- Vdd < 3.6V: 20 percent of Vdd

The C_{SS} capacitor connected to SS (Figures 1.1 and 1.2) should be adjusted so that the waveform approximates the above amplitude, \pm 10 percent, during normal operation in the target circuit. Where the bursts are of differing lengths, the adjustment should be done for the longer burst. If this is done, the circuit will give a spectral modulation of 12-15 percent. A typical value of C_{SS} is 100nF.

3.3 Cs Sample Capacitors - Sensitivity

The Cs sample capacitors accumulate the charge from the key electrodes and hence determine sensitivity. The values of Cs can differ for each channel, permitting differences in sensitivity from key to key or to balance unequal sensitivities. Higher values of Cs make the corresponding key more sensitive.

Unequal sensitivities can occur due to key size and placement differences, stray wiring capacitances, and option resistor connection.

- More stray capacitance on an electrode or sense trace will decrease sensitivity on the corresponding key; Cs will have to be increased to compensate.
- An option resistor pulling low will increase sensitivity on the corresponding key; Cs will have to be reduced to compensate.

The Cs capacitors can be virtually any plastic film or low to medium-K ceramic capacitor. Acceptable capacitor types for most uses include PPS film, polypropylene film, and NP0 and X5R / X7R ceramics. Lower grades than X5R / X7R are not advised.

For most applications Cs will be in the range 680pF to 50nF; larger values of Cs require better quality capacitors to ensure reliable sensing. In a few applications sufficient sensitivity will be achieved with Cs less than 680pF.

If very high sensitivity is required then the 50nF value may be exceeded hence the 100nF maximum in Section 4.2, page 13; in this case greater care should be taken over the QT1103 circuit layout and interactions with neighboring electronics.

As the sensitivity of the keys, and hence the required values of Cs, are affected by the presence and connection of the option resistors (see Section 2.2, page 9), then final selection of Cs values should take place after the options choice has been finalized.

3.4 R_{sns} Resistors

Series resistors R_{SNS} (R_{SNS0}...R_{SNS9}) are in line with the electrode connections and should be used to limit electrostatic discharge (ESD) currents and to suppress radio frequency interference (RFI). For most applications R_{SNS} will be in the range 4.7k Ω to 33k Ω each. In a few applications with low loading on the sense keys the value may be up to 100k Ω .

Although these resistors may be omitted, the device may become susceptible to external noise or RFI. For details of how to select these resistors see the Application Note AN-KD02, downloadable from the Quantum website <http://www.qprox.com> (go to the Support tab and click Application Notes).

3.5 Power Supply

The power supply can range from 2.8V to 5.0V. If this fluctuates slowly with temperature, the device will track and compensate for these changes automatically with only minor changes in sensitivity. If the supply voltage drifts or shifts quickly, the drift compensation mechanism will not be able to keep up, causing sensitivity anomalies or false detections.

The power supply should be locally regulated using a three-terminal device, to between 2.8V and 5.0V. If the supply is shared with another electronic system, care should be taken to ensure that the supply is free of digital spikes, sags, and surges which can cause adverse effects. It is not recommended to include a series inductor in the power supply to the QT1103.

For proper operation a 0.1 μ F or greater bypass capacitor must be used between Vdd and Vss. The bypass capacitor should be routed with very short tracks to the device's Vss and Vdd pins.

3.6 PCB Layout and Construction

Refer to Quantum application note AN-KD02 for information related to layout and construction matters.

4 Specifications

4.1 Absolute Maximum Specifications

Operating temperature, Ta.....	-40° ~ +85°C
Storage temp, Ts.....	-50° ~ +125°C
Vdd.....	-0.3 ~ +6.0V
Max continuous pin current, any control or drive pin.....	±20mA
Short circuit duration to ground or Vdd, any pin.....	infinite
Voltage forced onto any pin.....	-0.3V ~ (Vdd + 0.3) Volts

4.2 Recommended Operating Conditions

Operating temperature, Ta.....	-40° ~ +85°C
VDD.....	+2.8 ~ +5.0V
Short-term supply ripple+noise.....	±5mV/s
Long-term supply stability.....	±100mV
Cs range.....	≤100nF
Cx range.....	0 ~ 50pF

4.3 AC Specifications

Vdd = 5.0V, Ta = recommended, Cx = 5pF, Cs = 4.7nF; circuit of Figure 1.1

Parameter	Description	Min	Typ	Max	Units	Notes
Trc	Recalibration time		150		ms	
Fc	Burst center frequency		132		kHz	
Fm	Burst modulation, percent		15		%	Total deviation
Tpc	Sample pulse duration		2		µs	Pulses appear 33 percent longer when viewed on an oscilloscope.
Tsu	Startup time from cold start		260		ms	
Tbd	Burst duration		2.5		ms	All three bursts
Tdtf	Response time - Fast mode		14		ms	
Tdtn	Response time - Normal mode		28		ms	
Tdtl	Response time - LP mode		110		ms	110ms LP setting
Tdrf	Release time - Fast mode		10		ms	End of touch
Tdrn	Release time - Normal mode		14		ms	End of touch
Tres	External reset low pulse width	1			µs	
bps	Serial communications speed	8,000		38,400	baud	

4.4 DC Specifications

Vdd = 5.0V, Ta = recommended, Cx = 5pF, Cs = 4.7nF, Ta = recommended range; circuit of Figure 1.1 unless noted

Parameter	Description	Min	Typ	Max	Units	Notes
Iddn	Average supply current, normal mode*		4.2 2.5 1.8 1.4	8	mA	@ VDD = 5.0 @ VDD = 4.0 @ VDD = 3.3 @ VDD = 2.8
Iddl	Average supply current, LP mode*	22 15			µA	@ VDD = 3.3V; 190ms LP mode @ VDD = 2.8V; 190ms LP mode
	Average supply current, LP mode	48 34			µA	@ VDD = 3.3V @ VDD = 2.8V
	Average supply current, LP mode, keys on bursts A and B only	36 24			µA	@ VDD = 3.3V @ VDD = 2.8V
	Average supply current, LP mode, keys on burst B only	20 14			µA	@ VDD = 3.3V @ VDD = 2.8V
Vdds	Average supply turn-on slope	100			V/s	
Vil	Low input logic level			0.7	V	
Vhl	High input logic level	3.5			V	
Vol	Low output voltage			0.5	V	7mA sink
Voh	High output voltage	Vdd-0.5			V	2.5mA source
Iil	Input leakage current			±1	µA	
Ar	Acquisition resolution		8		bits	

*No spread spectrum circuit

4.5 Signal Processing

Vdd = 5.0V, Ta = recommended, Cx = 5pF, Cs = 4.7nF, 2µs QT Pulses

Description	Value	Units	Notes
Detection threshold	10	counts	Threshold for increase in Cx load
Detection hysteresis	2	counts	
Anti-detection threshold	6	counts	Threshold for decrease of Cx load
Anti-detection recalibration delay	2	secs	Time to recalibrate if Cx load has exceeded anti-detection threshold
Detect Integrator filter, normal mode	6	samples	Must be consecutive or detection fails
Detect Integrator filter, Fast mode	3	samples	Must be consecutive or detection fails
Max On-Duration	10, 60, inf	secs	Option pin selected
Normal drift compensation rate	2,000	ms/level	Towards increasing Cx load
Anti drift compensation rate	500	ms/level	Towards decreasing Cx load

4.6 Idd Curves

All Idd curves are average values, under the following conditions: $C_x = 5\text{pF}$, $C_s = 4.7\text{nF}$, $T_a = 20^\circ\text{C}$; no spread-spectrum circuit. Refer to page 9 for more information about optimization of LP modes.

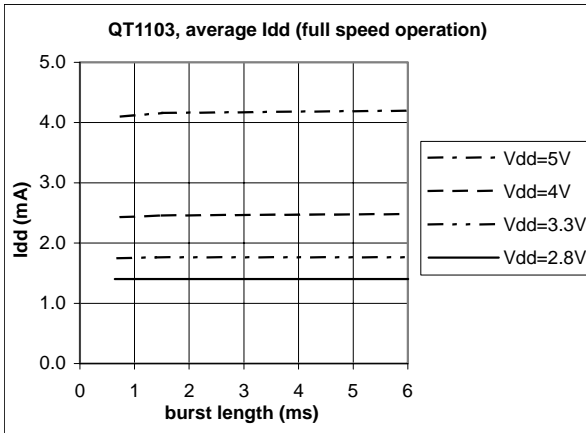

Full speed operation

Low Power operation (optimized - only burst B in use)

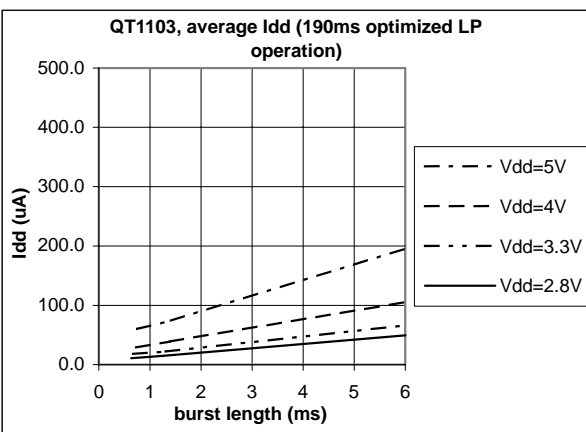
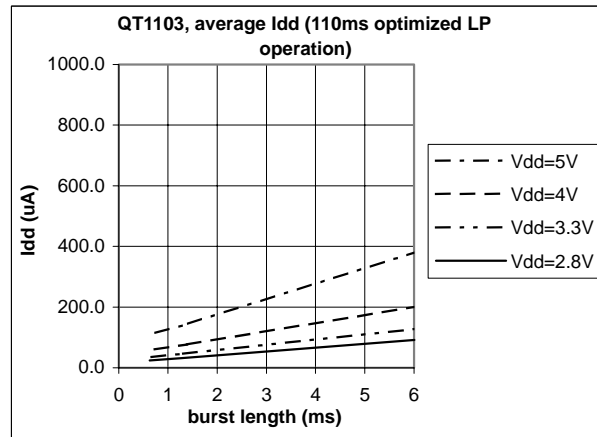
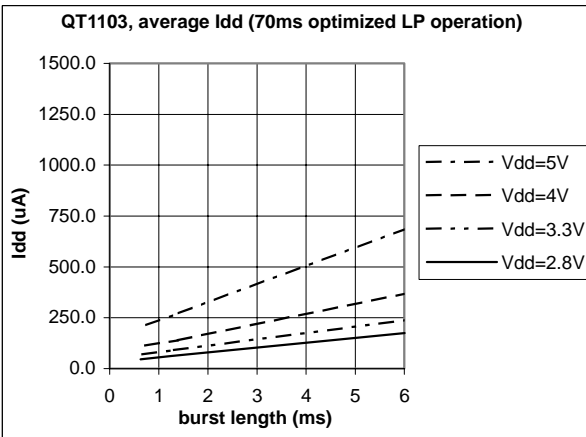

Low Power operation (optimized - only burst A and B in use)

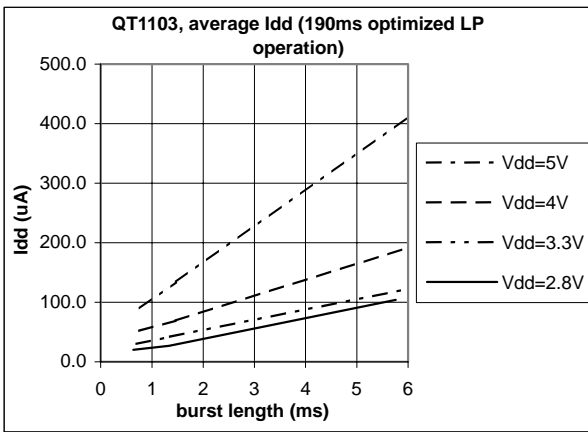
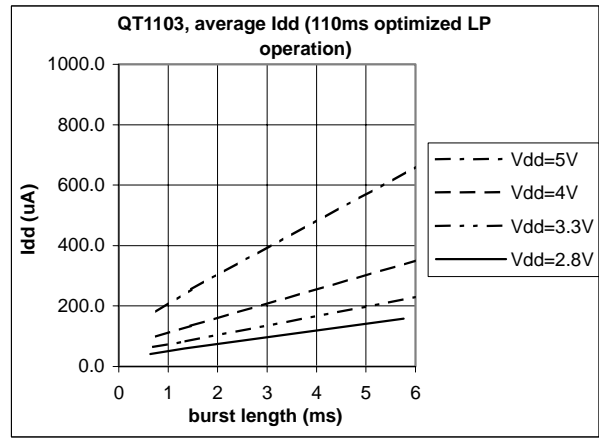
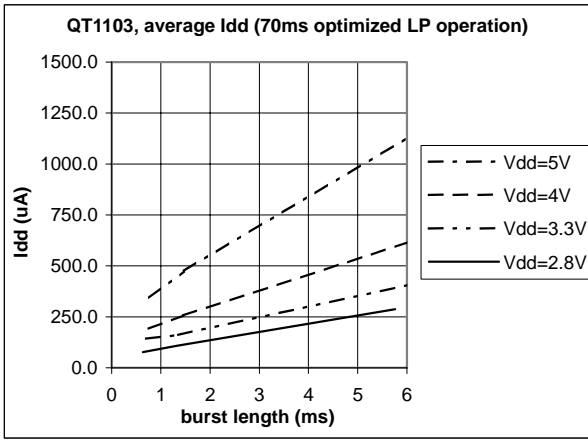

Low Power operation (non-optimized)

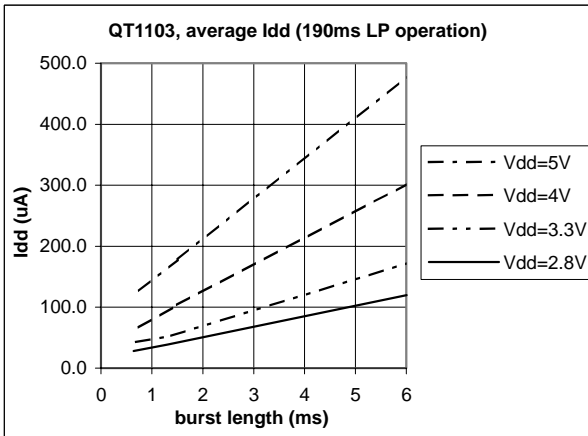
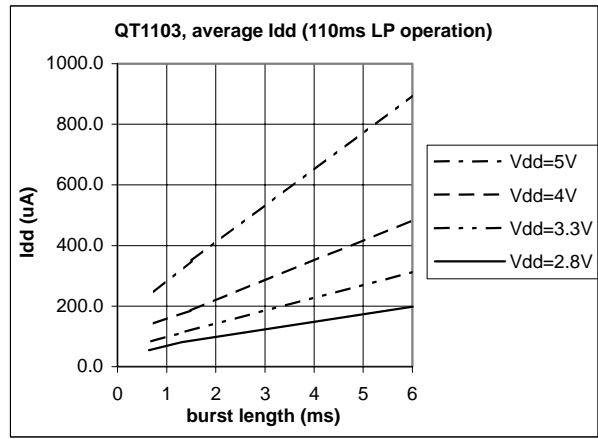
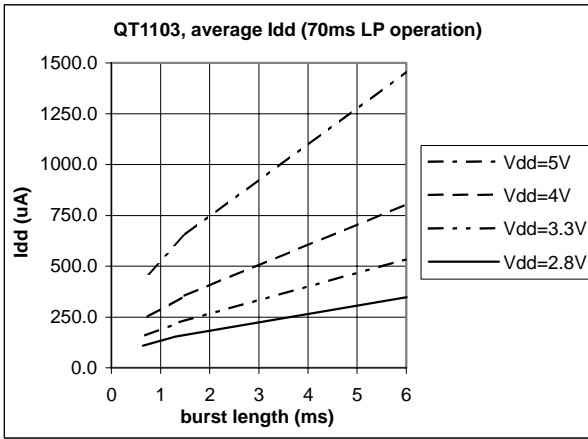

4.7 LP Mode Typical Response Times

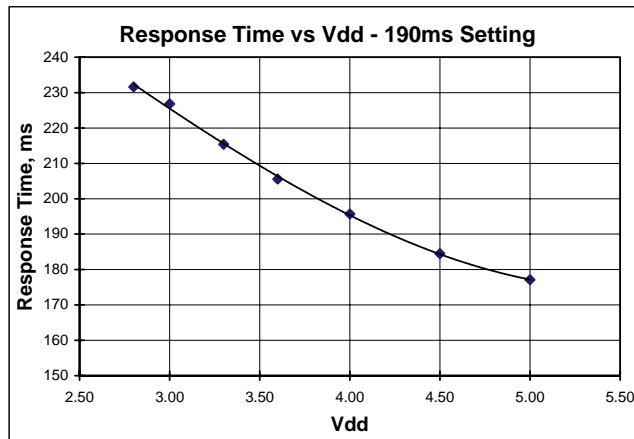
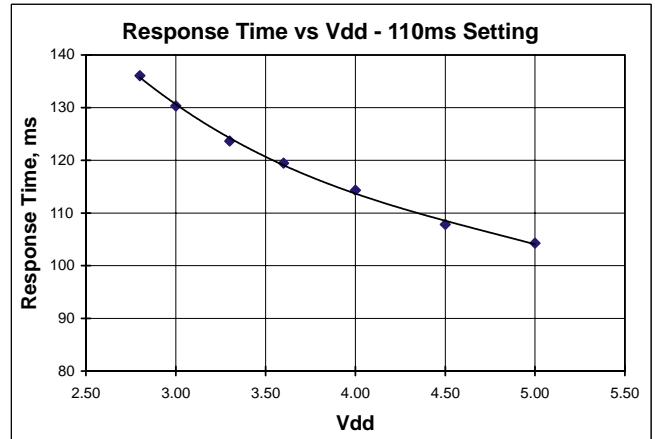
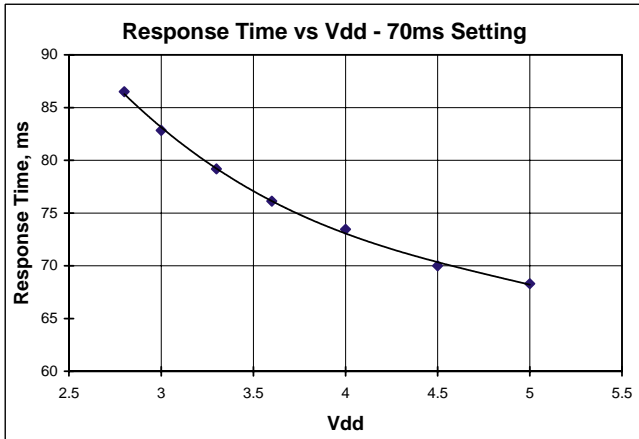

4.8 Mechanical Dimensions

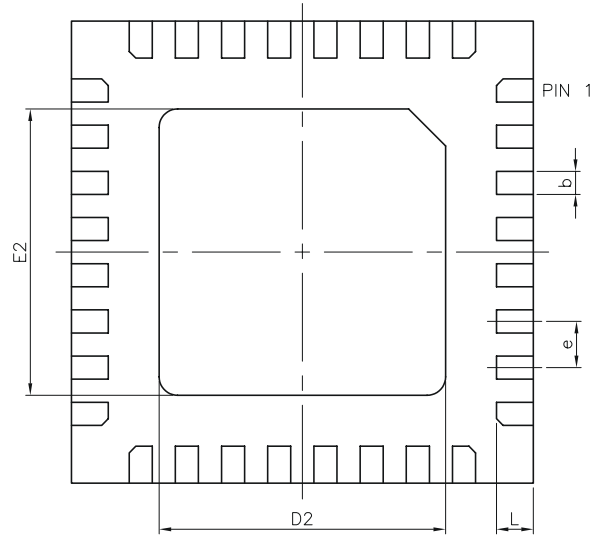
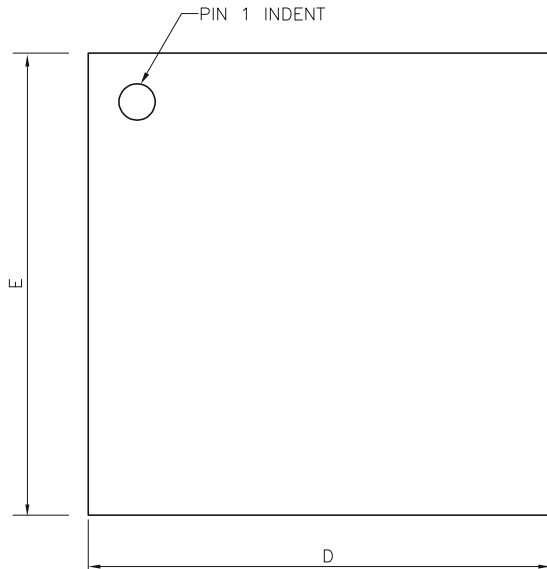

Dimensions In Millimeters			
Symbol	Minimum	Nominal	Maximum
A	0.70	-	0.95
A1	0.00	0.02	0.05
b	0.18	0.25	0.32
C	-	0.20 REF	-
D	4.90	5.00	5.10
D2	3.05	-	3.65
E	4.90	5.00	5.10
E2	3.05	-	3.65
e	-	0.50	-
L	0.30	0.40	0.50
y	0.00	-	0.075

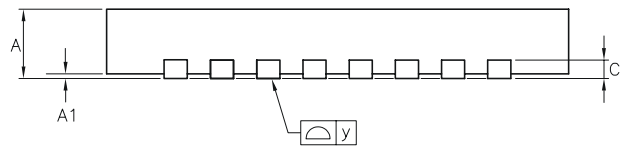

Note: that there is no functional requirement for the large pad on the underside of the 32-QFN package to be soldered to the substrate. If the final application does require this area to be soldered for mechanical reasons, the pad(s) to which it is soldered to must be isolated and contained under the 32-QFN footprint only.

4.9 Part Marking

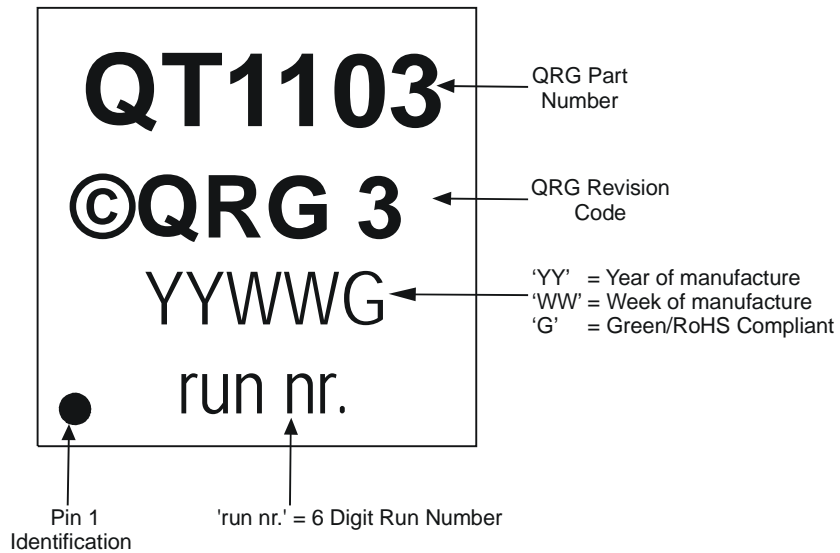

4.10 Moisture Sensitivity Level (MSL)

MSL Rating	Peak Body Temperature	Specifications
MSL3	260°C	IPC/JEDEC J-STD-020C

5 Datasheet Control

5.1 Changes

Changes this issue (datasheet issue 03)

Front page.

5.2 Numbering Convention

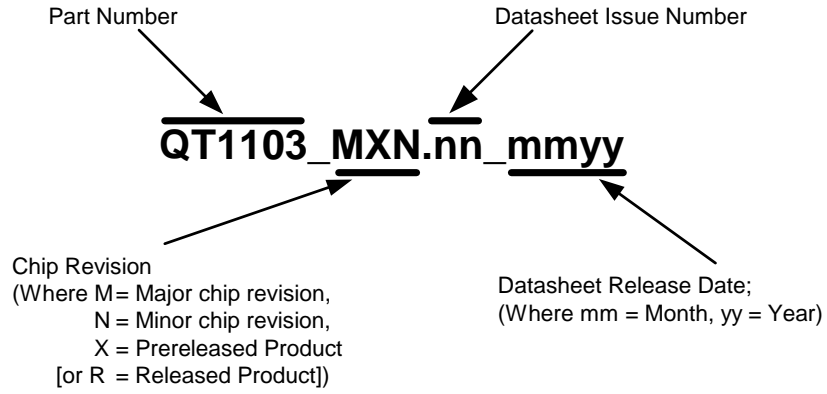

*A minor chip revision (N) is defined as a revision change which does not affect product functionality or datasheet.
The value of N is only stated for released parts (R).*



Copyright © 2006-2007 QRG Ltd. All rights reserved.
Patented and patents pending

Corporate Headquarters

1 Mitchell Point
Ensign Way, Hamble SO31 4RF
Great Britain
Tel: +44 (0)23 8056 5600 Fax: +44 (0)23 8045 3939

www.qprox.com

North America

651 Holiday Drive Bldg. 5 / 300
Pittsburgh, PA 15220 USA
Tel: 412-391-7367 Fax: 412-291-1015

The specifications set out in this document are subject to change without notice. All products sold and services supplied by QRG are subject to QRG's Terms and Conditions of sale and services. QRG patents, trademarks and Terms and Conditions can be found online at <http://www.qprox.com/about/legal.php>. Numerous further patents are pending, one or more which may apply to this device or the applications thereof.

QRG products are not suitable for medical (including lifesaving equipment), safety or mission critical applications or other similar purposes. Except as expressly set out in QRG's Terms and Conditions, no licenses to patents or other intellectual property of QRG (express or implied) are granted by QRG in connection with the sale of QRG products or provision of services. QRG will not be liable for customer product design and customers are entirely responsible for their products and applications which incorporate QRG's products.

Development Team: John Dubery, Alan Bowens, Matthew Trend



Looking for pricing, stock, or lifecycle information?

Click below to explore more details on WIN SOURCE:

 [View QT1103-ISG on WIN SOURCE](#)

 [Atmel Information](#)

Optimize Your Supply Chain with WIN SOURCE Solutions

-  Global Sourcing Solution
-  Obsolete Management
-  Cost Control Management
-  Shortage Management
-  Alternative Solution
-  Excess Inventory Management