



**THE DATASHEET OF
RFP50N06**



MOSFET – Power, N-Channel

60 V, 50 A, 22 mΩ

RFP50N06

These N-Channel power MOSFETs are manufactured using the MegaFET process. This process, which uses feature sizes approaching those of LSI integrated circuits gives optimum utilization of silicon, resulting in outstanding performance. They were designed for use in applications such as switching regulators, switching converters, motor drivers, and relay drivers. These transistors can be operated directly from integrated circuits.

Formerly developed type TA49018.

Features

- 50 A, 60 V
- $r_{DS(ON)} = 0.022 \Omega$
- Temperature Compensating PSpice™ Model
- Peak Current vs. Pulse Width Curve
- UIS Rating Curve
- 175°C Operating Temperature
- This Device is Pb-Free and is RoHS Compliant

Specifications

ABSOLUTE MAXIMUM RATINGS

($T_C = 25^\circ\text{C}$, unless otherwise specified)

Symbol	Parameter		Rating	Unit
V_{DSS}	Drain to Source Voltage (Note 1)		60	V
V_{DGR}	Drain to Gate Voltage ($R_{GS} = 20 \text{ k}\Omega$) (Note 1)		60	V
V_{GS}	Gate to Source Voltage		± 20	V
I_D	Drain Current	Continuous (Figure 2)	50	A
		Pulsed (Figure 5)		
I_{DM}	Pulsed		(Figure 5)	
E_{AS}	Pulsed Avalanche Rating		(Figure 6)	
P_D	Power Dissipation		131	W
	Linear Derating Factor		0.877	W/°C
T_J, T_{STG}	Operating and Storage Temperature		-55 to 175	°C
T_L	Maximum Temperature for Soldering Leads at 0.063 inch (1.6 mm) from Case for 10 s		300	°C
T_{pkg}	Maximum Temperature for Soldering Package Body for 10 s, see Techbrief 334		260	°C

Stresses exceeding those listed in the Maximum Ratings table may damage the device. If any of these limits are exceeded, device functionality should not be assumed, damage may occur and reliability may be affected.

1. $T_J = 25^\circ\text{C}$ to 150°C

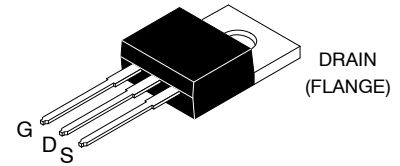

TO-220-3LD
CASE 340AT

SYMBOL

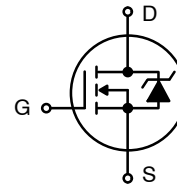

MARKING DIAGRAM

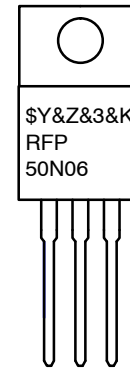

- \$Y = onsemi Logo
- &Z = Assembly Plant Code
- &3 = Date Code (Year & Week)
- &K = Lot
- RFP50N06 = Specific Device Code

ORDERING INFORMATION

Device	Package	Shipping
RFP50N06	TO-220-3LD (Pb-Free)	800 units / Tube

RFP50N06

ELECTRICAL CHARACTERISTICS (T_C = 25°C, unless otherwise noted)

Parameter	Symbol	Test Conditions	Min	Typ	Max	Units	
Drain to Source Breakdown Voltage	BV _{DSS}	I _D = 250 μA, V _{GS} = 0 V (Figure 11)	60	–	–	V	
Gate to Source Threshold Voltage	V _{GS(TH)}	V _{GS} = V _{DS} , I _D = 250 μA (Figure 10)	2	–	4	V	
Zero Gate Voltage Drain Current	I _{DSS}	V _{DS} = 60 V, V _{GS} = 0 V	T _C = 25°C	–	–	1	μA
			T _C = 150°C	–	–	50	μA
Gate to Source Leakage Current	I _{GSS}	V _{GS} = ±20 V	–	–	±100	nA	
Drain to Source On Resistance	r _{DS(ON)}	I _D = 50 A, V _{GS} = 10 V (Figure 9)	–	–	0.022	Ω	
Turn-On Time	t _{ON}	V _{DD} = 30 V, I _D = 50 A R _L = 0.6 Ω, V _{GS} = 10 V R _{GS} = 3.6 Ω (Figure 13)	–	–	95	ns	
Turn-On Delay Time	t _{d(ON)}		–	12	–	ns	
Rise Time	t _r		–	55	–	ns	
Turn-Off Delay Time	t _{d(OFF)}		–	37	–	ns	
Fall Time	t _f		–	13	–	ns	
Turn-Off Time	t _{OFF}		–	–	75	ns	
Total Gate Charge	Q _{g(TOT)}	V _{GS} = 0 to 20 V	–	125	150	nC	
Gate Charge at 10V	Q _{g(10)}	V _{GS} = 0 to 10 V					
Threshold Gate Charge	Q _{g(TH)}	V _{GS} = 0 to 2 V					
		V _{DD} = 48 V, I _D = 50 A, R _L = 0.96 Ω I _{g(REF)} = 1.45 mA (Figure 13)					
Input Capacitance	C _{ISS}	V _{DS} = 25 V, V _{GS} = 0 V	–	2020	–	pF	
Output Capacitance	C _{OSS}	f = 1 MHz	–	600	–	pF	
Reverse Transfer Capacitance	C _{RSS}	(Figure 12)	–	200	–	pF	
Thermal Resistance Junction to Case	R _{θJC}	(Figure 3)	–	–	1.14	°C/W	
Thermal Resistance Junction to Ambient	R _{θJA}	TO-220	–	–	62	°C/W	

SOURCE TO DRAIN DIODE CHARACTERISTICS

Source to Drain Diode Voltage	V _{SD}	I _{SD} = 50 A	–	–	1.5	V
Output Capacitance	t _{rr}	I _{SD} = 50 A, dI _{SD} /dt = 100 A/μs	–	–	125	ns

Product parametric performance is indicated in the Electrical Characteristics for the listed test conditions, unless otherwise noted. Product performance may not be indicated by the Electrical Characteristics if operated under different conditions.

TYPICAL PERFORMANCE CHARACTERISTICS (unless otherwise specified)

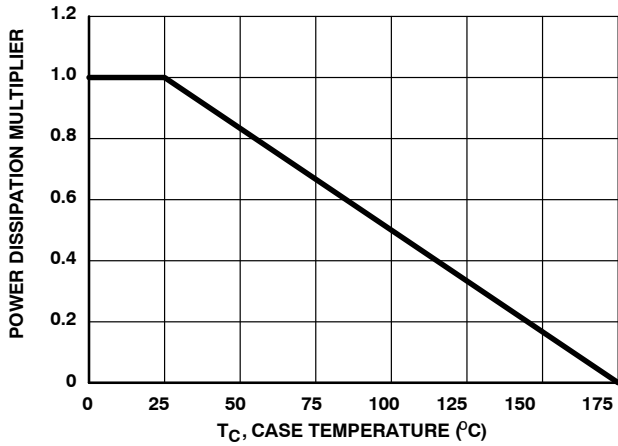

Figure 1. Normalized Power Dissipation vs. Case Temperature

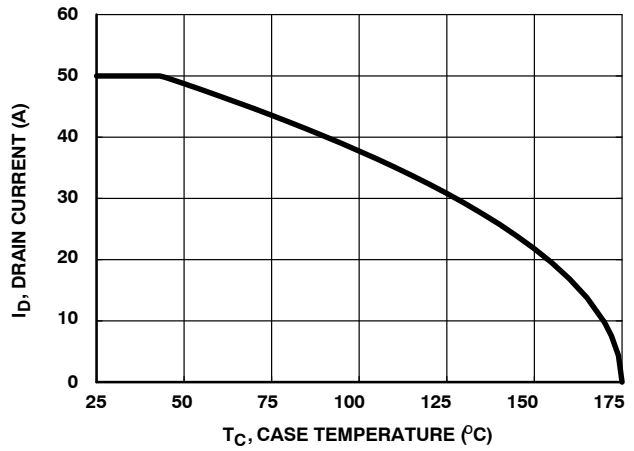

Figure 2. Maximum Continuous Drain Current vs. Case Temperature

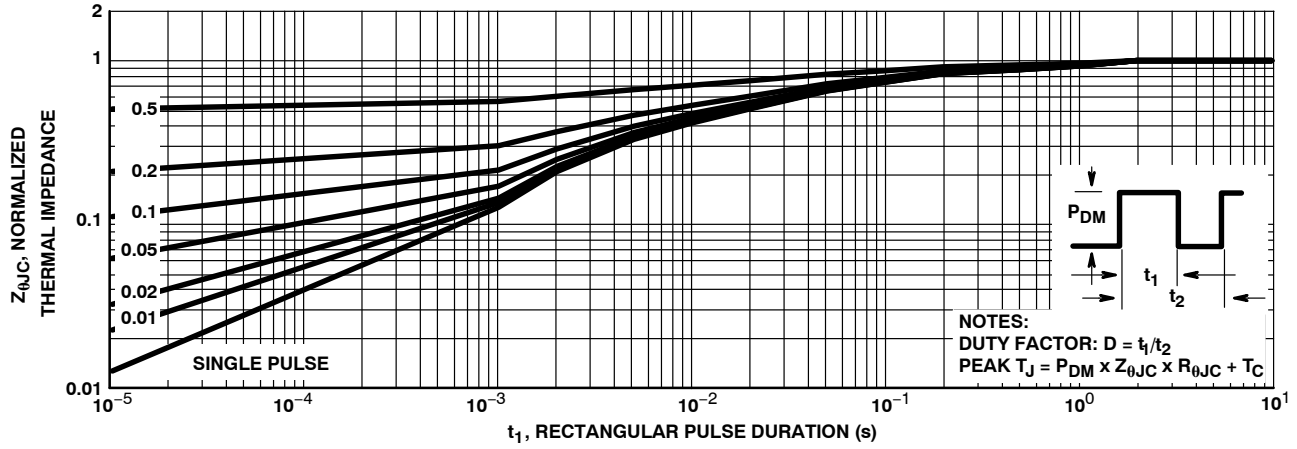

Figure 3. Normalized Maximum Transient Thermal Impedance

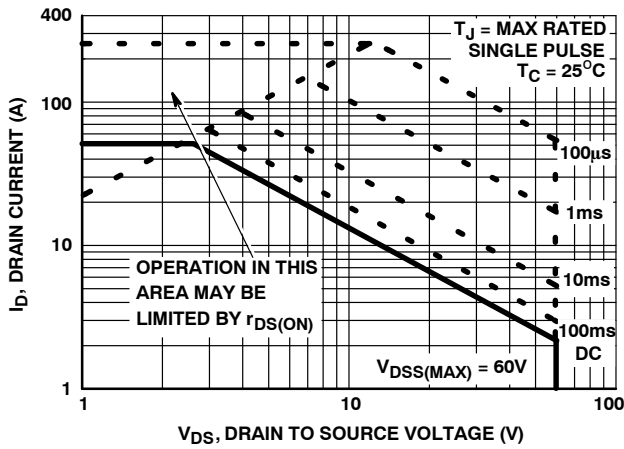

Figure 4. Forward Bias Safe Operating Area

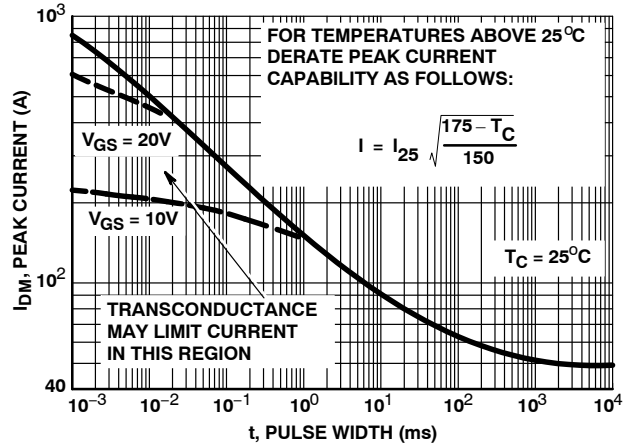

Figure 5. Peak Current Capability

TYPICAL PERFORMANCE CHARACTERISTICS (unless otherwise specified) (continued)

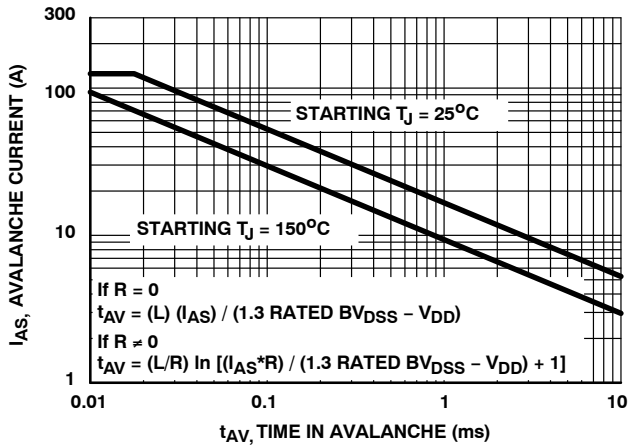

Figure 6. Unclamped Inductive Switching Capability

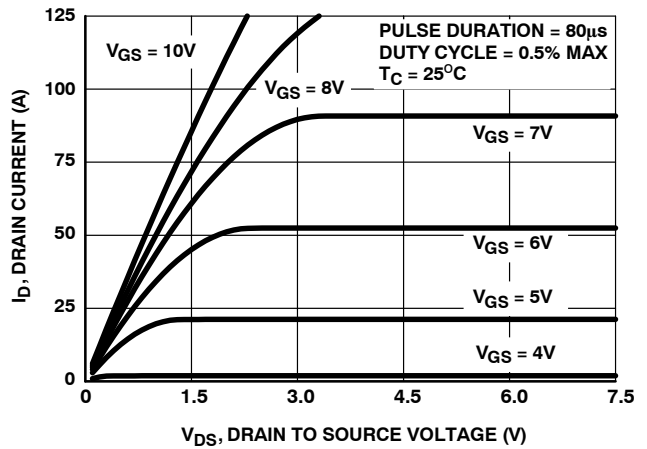

Figure 7. Saturation Characteristics

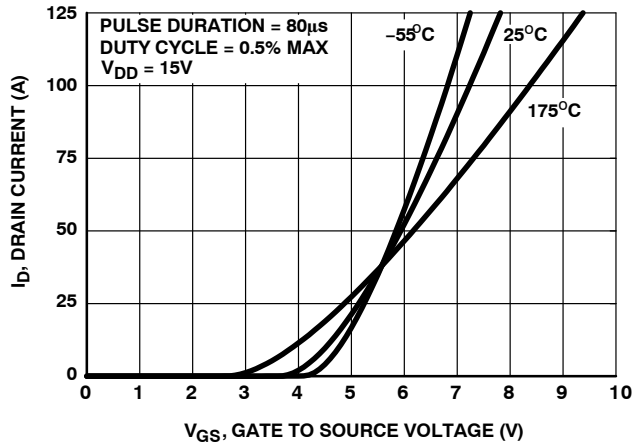

Figure 8. Transfer Characteristics

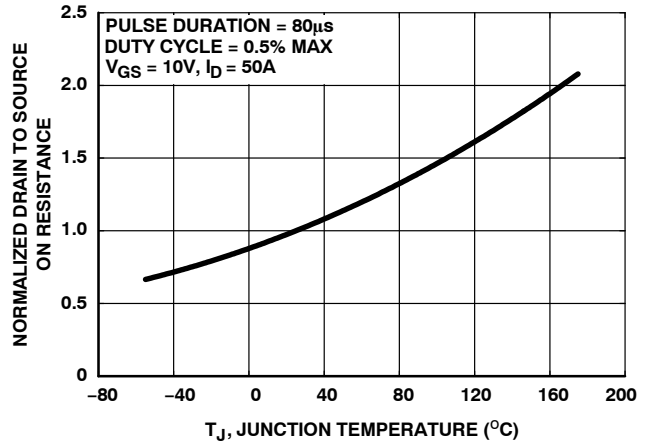

Figure 9. Normalized Drain to Source On Resistance vs. Junction Temperature

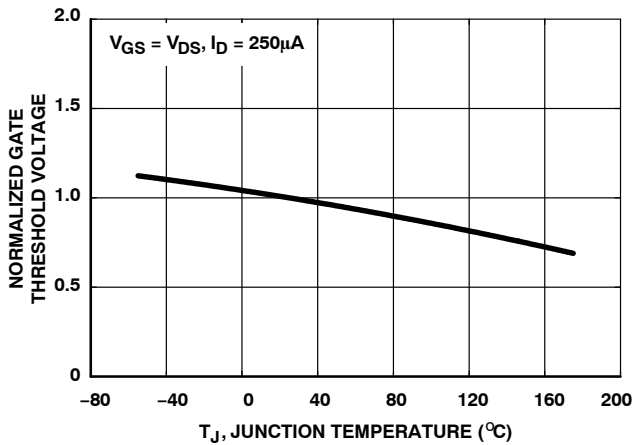

Figure 10. Normalized Gate Threshold Voltage vs. Junction Temperature

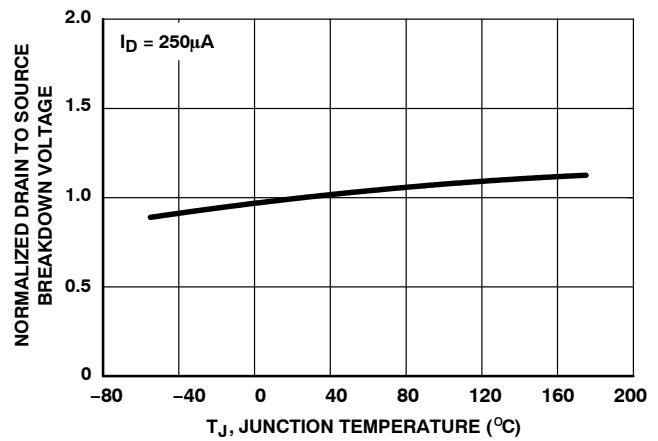

Figure 11. Normalized Drain to Source Breakdown Voltage vs. Junction Temperature

TYPICAL PERFORMANCE CHARACTERISTICS (unless otherwise specified) (continued)

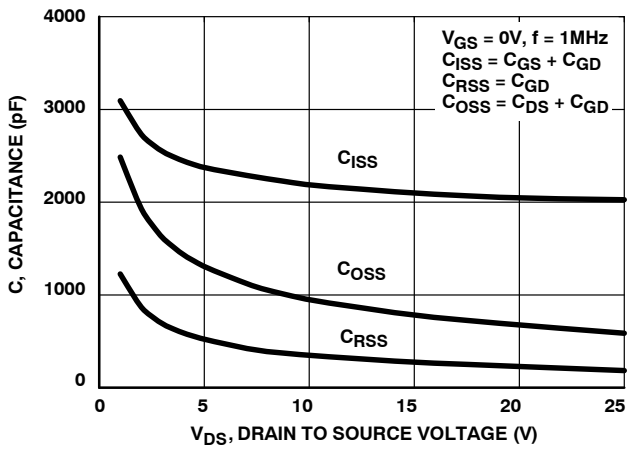

Figure 12. Capacitance vs. Drain to Source Voltage

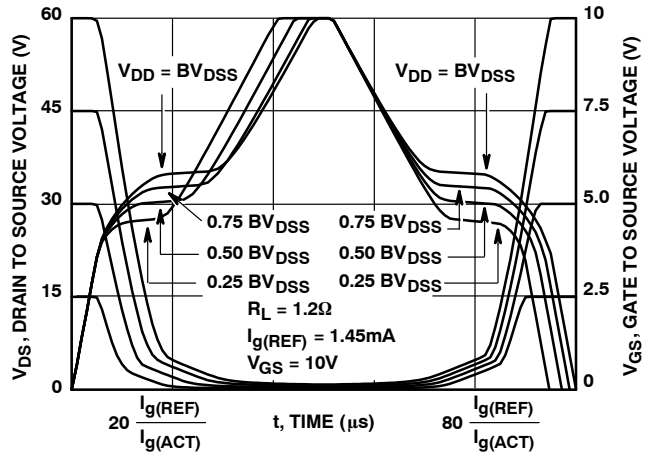

Figure 13. Normalized Switching Waveforms for Constant Gate Current

TEST CIRCUITS AND WAVEFORMS

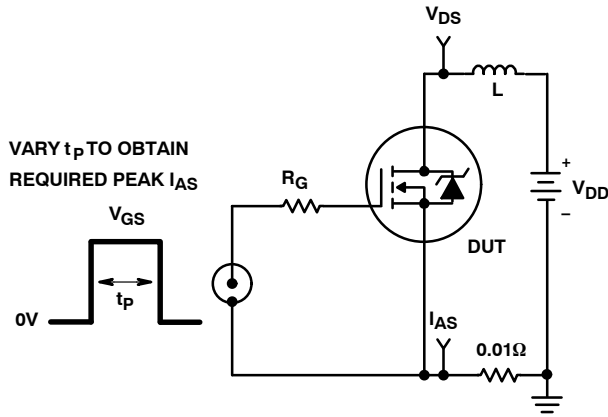

Figure 14. Unclamped Energy Test Circuit

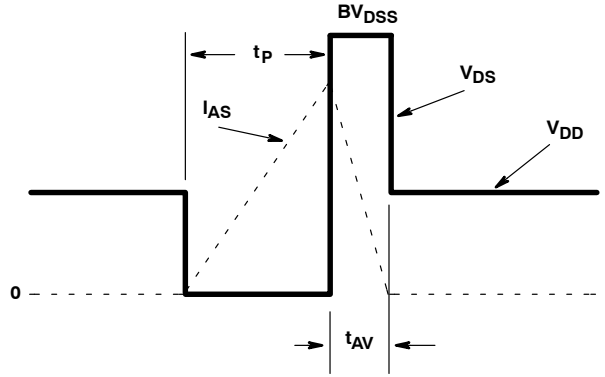

Figure 15. Unclamped Energy Waveforms

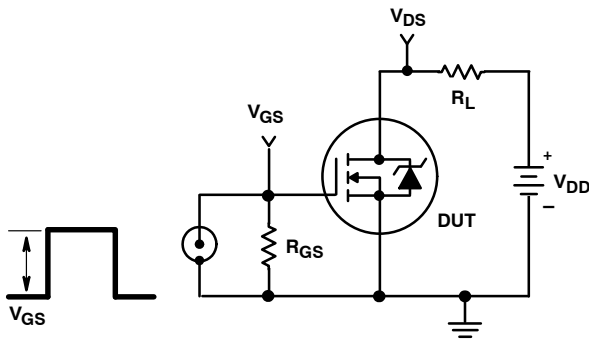

Figure 16. Switching Time Test Circuit

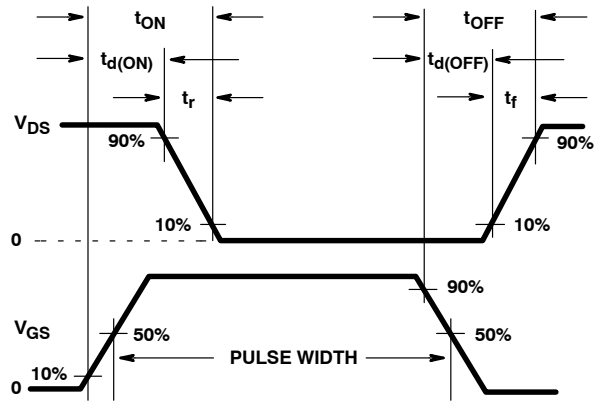

Figure 17. Switching Waveforms

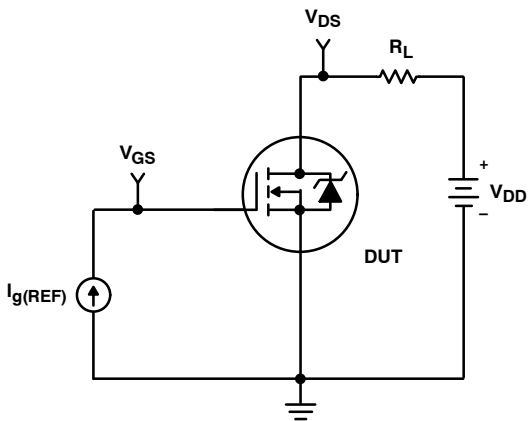

Figure 18. Gate Charge Test Circuit

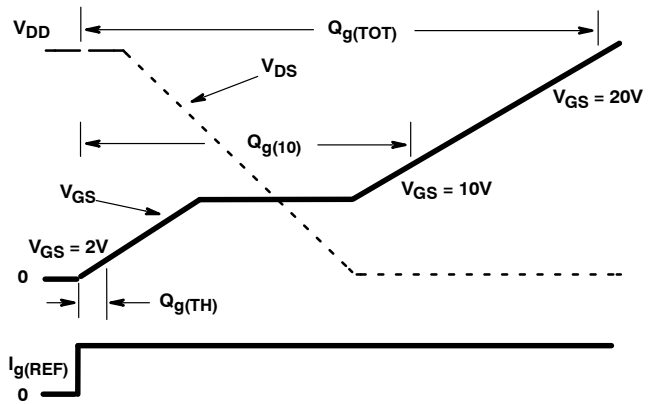

Figure 19. Gate Charge Waveforms

RFP50N06

PSPICE ELECTRICAL MODEL

.SUBCKT RFP50N06213

REV 2/22/93

*NOM TEMP = 25°C

CA 12 8 3.68e-9
 CB 15 14 3.625e-9
 CIN 6 8 1.98e-9

DBODY 7 5 DBDMOD
 DBREAK 5 11 DBKMOD
 DPLCAP 10 5 DPLCAPMOD

EBREAK 11 7 17 18 64.59
 EDS 14 8 5 8 1
 EGS 13 8 6 8 1
 ESG 6 10 6 8 1
 EVTO 20 6 18 8 1

IT 8 17 1

LDRAIN 2 5 1e-9
 LGATE 1 9 5.65e-9
 LSOURCE 3 7 4.13e-9

MOS1 16 6 8 8 MOSMOD M=0.99
 MOS2 16 21 8 8 MOSMOD M=0.01

RBREAK 17 18 RBKMOD 1
 RDRAIN 5 16 RDSMOD 1e-4
 RGATE 9 20 0.690
 RIN 6 8 1e9
 RSOURCE 8 7 RDSMOD 12e-3
 RVTO 18 19 RVTOMOD 1

S1A 6 12 13 8 S1AMOD
 S1B 13 12 13 8 S1BMOD
 S2A 6 15 14 13 S2AMOD
 S2B 13 15 14 13 S2BMOD

VBAT 8 19 DC 1
 VTO 21 6 0.678

.MODEL DBDMOD D (IS=9.85e-13 RS=4.91e-3 TRS1=2.07e-3 TRS2=2.51e-7 CJO=2.05e-9 TT=4.33e-8)
 .MODEL DBKMOD D (RS=1.98e-1 TRS1=2.35e-4 TRS2=-3.83e-6)
 .MODEL DPLCAPMOD D (CJO=1.42e-9 IS=1e-30 N=10)
 .MODEL MOSMOD NMOS (VTO=3.65 KP=35 IS=1e-30 N=10 TOX=1 L=1u W=1u)
 .MODEL RBKMOD RES (TC1=1.23e-3 TC2=-2.34e-7)
 .MODEL RDSMOD RES (TC1=5.01e-3 TC2=1.49e-5)
 .MODEL RVTOMOD RES (TC1=-5.03e-3 TC2=-5.16e-6)
 .MODEL S1AMOD VSWITCH (RON=1e-5 ROFF=0.1 VON=-6.75 VOFF=-2.5)
 .MODEL S1BMOD VSWITCH (RON=1e-5 ROFF=0.1 VON=-2.5 VOFF=-6.75)
 .MODEL S2AMOD VSWITCH (RON=1e-5 ROFF=0.1 VON=-2.7 VOFF=2.3)
 .MODEL S2BMOD VSWITCH (RON=1e-5 ROFF=0.1 VON=2.3 VOFF=-2.7)

.ENDS

NOTE: For further discussion of the PSPICE model consult **A New PSPICE Sub-Circuit for the Power MOSFET Featuring Global Temperature Options**; authors, William J. Hepp and C. Frank Wheatley.

PSPICE is a trademark of MicroSim Corporation.

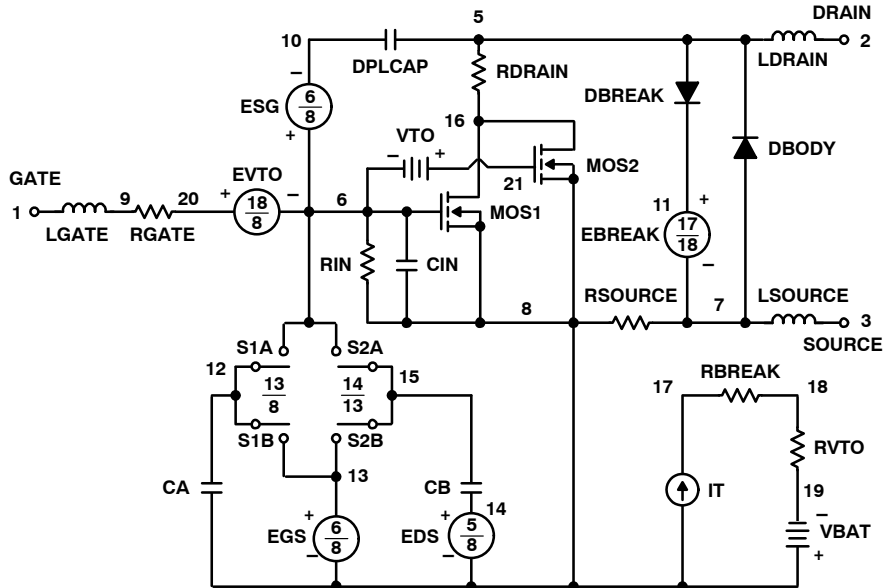

MECHANICAL CASE OUTLINE

PACKAGE DIMENSIONS

ON Semiconductor®

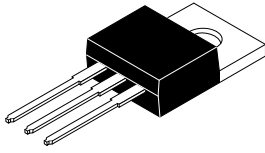

Scale 1:1

TO-220-3LD CASE 340AT ISSUE A

DATE 03 OCT 2017

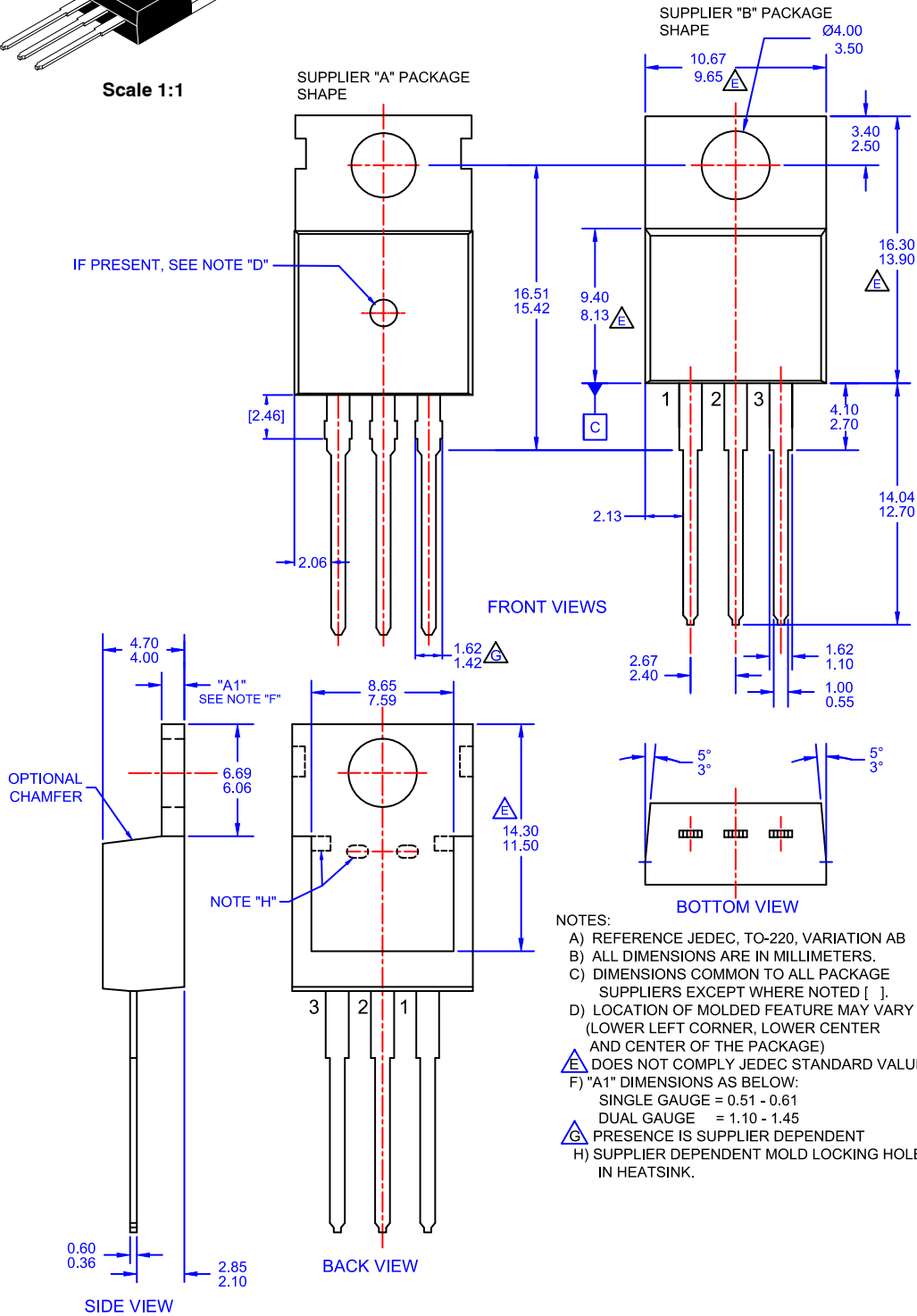

- NOTES:
- A) REFERENCE JEDEC, TO-220, VARIATION AB
 - B) ALL DIMENSIONS ARE IN MILLIMETERS.
 - C) DIMENSIONS COMMON TO ALL PACKAGE SUPPLIERS EXCEPT WHERE NOTED [].
 - D) LOCATION OF MOLDED FEATURE MAY VARY (LOWER LEFT CORNER, LOWER CENTER AND CENTER OF THE PACKAGE)
 - E) DOES NOT COMPLY JEDEC STANDARD VALUE.
 - F) "A1" DIMENSIONS AS BELOW:
 SINGLE GAUGE = 0.51 - 0.61
 DUAL GAUGE = 1.10 - 1.45
 - G) PRESENCE IS SUPPLIER DEPENDENT
 - H) SUPPLIER DEPENDENT MOLD LOCKING HOLES IN HEATSINK.

DOCUMENT NUMBER:	98AON13818G	Electronic versions are uncontrolled except when accessed directly from the Document Repository. Printed versions are uncontrolled except when stamped "CONTROLLED COPY" in red.
DESCRIPTION:	TO-220-3LD	PAGE 1 OF 1

ON Semiconductor and are trademarks of Semiconductor Components Industries, LLC dba ON Semiconductor or its subsidiaries in the United States and/or other countries. ON Semiconductor reserves the right to make changes without further notice to any products herein. ON Semiconductor makes no warranty, representation or guarantee regarding the suitability of its products for any particular purpose, nor does ON Semiconductor assume any liability arising out of the application or use of any product or circuit, and specifically disclaims any and all liability, including without limitation special, consequential or incidental damages. ON Semiconductor does not convey any license under its patent rights nor the rights of others.

onsemi, **Onsemi**, and other names, marks, and brands are registered and/or common law trademarks of Semiconductor Components Industries, LLC dba "**onsemi**" or its affiliates and/or subsidiaries in the United States and/or other countries. **onsemi** owns the rights to a number of patents, trademarks, copyrights, trade secrets, and other intellectual property. A listing of **onsemi**'s product/patent coverage may be accessed at www.onsemi.com/site/pdf/Patent-Marking.pdf. **onsemi** reserves the right to make changes at any time to any products or information herein, without notice. The information herein is provided "as-is" and **onsemi** makes no warranty, representation or guarantee regarding the accuracy of the information, product features, availability, functionality, or suitability of its products for any particular purpose, nor does **onsemi** assume any liability arising out of the application or use of any product or circuit, and specifically disclaims any and all liability, including without limitation special, consequential or incidental damages. Buyer is responsible for its products and applications using **onsemi** products, including compliance with all laws, regulations and safety requirements or standards, regardless of any support or applications information provided by **onsemi**. "Typical" parameters which may be provided in **onsemi** data sheets and/or specifications can and do vary in different applications and actual performance may vary over time. All operating parameters, including "Typicals" must be validated for each customer application by customer's technical experts. **onsemi** does not convey any license under any of its intellectual property rights nor the rights of others. **onsemi** products are not designed, intended, or authorized for use as a critical component in life support systems or any FDA Class 3 medical devices or medical devices with a same or similar classification in a foreign jurisdiction or any devices intended for implantation in the human body. Should Buyer purchase or use **onsemi** products for any such unintended or unauthorized application, Buyer shall indemnify and hold **onsemi** and its officers, employees, subsidiaries, affiliates, and distributors harmless against all claims, costs, damages, and expenses, and reasonable attorney fees arising out of, directly or indirectly, any claim of personal injury or death associated with such unintended or unauthorized use, even if such claim alleges that **onsemi** was negligent regarding the design or manufacture of the part. **onsemi** is an Equal Opportunity/Affirmative Action Employer. This literature is subject to all applicable copyright laws and is not for resale in any manner.

ADDITIONAL INFORMATION

TECHNICAL PUBLICATIONS:

Technical Library: www.onsemi.com/design/resources/technical-documentation
onsemi Website: www.onsemi.com

ONLINE SUPPORT: www.onsemi.com/support

For additional information, please contact your local Sales Representative at www.onsemi.com/support/sales

Looking for pricing, stock, or lifecycle information?

Click below to explore more details on WIN SOURCE:

- ⊖ [View RFP50N06 on WIN SOURCE](#)
- ⊖ [Fairchild/ON Semiconductor Information](#)

Optimize Your Supply Chain with WIN SOURCE Solutions

- ✓ Global Sourcing Solution
- ✓ Obsolete Management
- ✓ Cost Control Management
- ✓ Shortage Management
- ✓ Alternative Solution
- ✓ Excess Inventory Management