



**THE DATASHEET OF
RTR030P02TL**



1. TYPE RTR030P02
2. STRUCTURE SILICON P-CHANNEL MOS FET
3. APPLICATIONS SWITCHING

4. ABSOLUTE MAXIMUM RATINGS [Ta=25°C]

DRAIN-SOURCE VOLTAGE		V _{DSS}	· · ·	-20V
GATE-SOURCE VOLTAGE		V _{GSS}	· · ·	±12V
DRAIN CURRENT	CONTINUOUS	I _D	· · ·	±3.0A
	PULSED	I _{DP}	· · ·	±12A PW ≤ 10μs DUTY CYCLE ≤ 1%
SOURCE CURRENT	CONTINUOUS	I _S	· · ·	-0.8A
	PULSED	I _{SP}	· · ·	-3.2A
TOTAL POWER DISSIPATION		P _D	· · ·	1.0W MOUNTED ON A CERAMIC BOARD
CHANNEL TEMPERATURE		T _{ch}	· · ·	150°C
RANGE OF STRAGE TEMPERATURE		T _{stg}	· · ·	-55~150°C

5. THERMAL RESISTANCE

CHANNEL TO AMBIENT	R _{th(ch-a)}	· · ·	125°C/W MOUNTED ON A CERAMIC BOARD
--------------------	-----------------------	-------	------------------------------------

DESIGN	CHECK	APPROVAL	DATE : 1/AUG/2002	SPECIFICATION No. TSQ03120-RTR030P02
<i>H. Takada</i>	<i>S. Nijashida</i>	<i>J. Howashi</i>	REV. : 0	ROHM CO., LTD.

6. ELECTRICAL CHARACTERISTICS [Ta=25°C]

PARAMETER	ITEM	CONDITION	MIN.	TYP.	MAX.
GATE-SOURCE LEAKAGE	I _{GSS}	V _{GS} =±12V/V _{DS} =0V	-	-	±10μA
DRAIN-SOURCE BREAKDOWN VOLTAGE	V(BR)DSS	I _D =-1mA/V _{GS} =0V	-20V	-	-
ZERO GATE VOLTAGE DRAIN CURRENT	I _{DSS}	V _{DS} =-20V/V _{GS} =0V	-	-	-1μA
GATE THRESHOLD VOLTAGE	V _{GS(th)}	V _{DS} =-10V/I _D =-1mA	-0.7V	-	-2.0V
STATIC DRAIN-SOURCE ON-STATE RESISTANCE	R _{DS(on)} * PULSED	I _D =-3A/V _{GS} =-4.5V	-	55mΩ	75mΩ
		I _D =-3A/V _{GS} =-4.0V	-	60mΩ	85mΩ
		I _D =-1.5A V _{GS} =-2.5V	-	90mΩ	125mΩ
FORWARD TRANSFER ADMITTANCE	Y _{fs} * PULSED	V _{DS} =-10V I _D =-1.5A	2.5S	-	-
INPUT CAPACITANCE	C _{iss}	V _{DS} =-10V/V _{GS} =0V f=1MHz	-	840pF	-
OUTPUT CAPACITANCE	C _{oss}		-	140pF	-
REVERSE TRANSFER CAPACITANCE	C _{rss}		-	100pF	-
TURN-ON DELAY TIME	t _{d(on)} * PULSED	I _D =-1.5A V _{DD} ≐-15V V _{GS} =-4.5V R _L ≐10Ω R _{GS} =10Ω	-	12ns	-
RISE TIME	t _r * PULSED		-	20ns	-
TURN-OFF DELAY TIME	t _{d(off)} * PULSED		-	50ns	-
FALL TIME	t _f * PULSED		-	20ns	-
TOTAL GATE CHARGE	Q _g		-	9.3nC	-
GATE-SOURCE CHARGE	Q _{gs}	V _{DD} ≐-15V V _{GS} =-4.5V I _D =-3A	-	1.6nC	-
GATE-DRAIN CHARGE	Q _{gd}		-	2.6nC	-

BODY DIODE CHARACTERISTICS (SOURCE-DRAIN CHARACTERISTICS) [Ta=25°C]

PARAMETER	ITEM	CONDITION	MIN.	TYP.	MAX.
FORWARD VOLTAGE	V _{SD}	I _S =-0.8A/V _{GS} =0V	-	-	-1.2V

7. INNER CIRCUIT

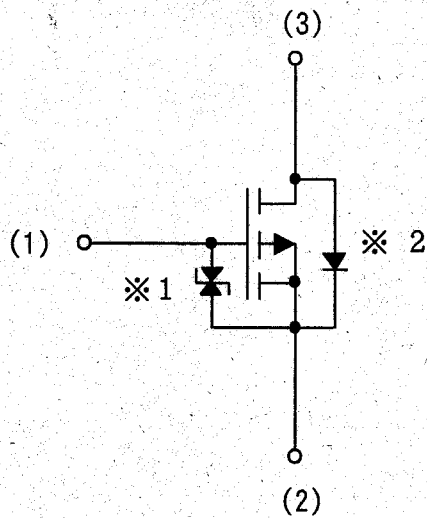

(1) GATE
(2) SOURCE
(3) DRAIN

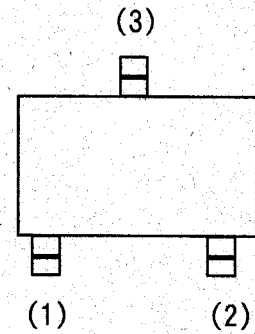

※ 1 ESD PROTECTION DIODE
※ 2 BODY DIODE

8. MARKING

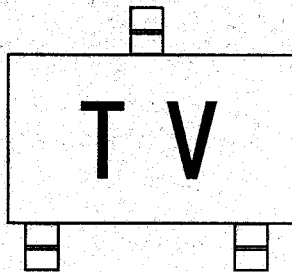

“TV” MEANS RTR030P02.

Dimension

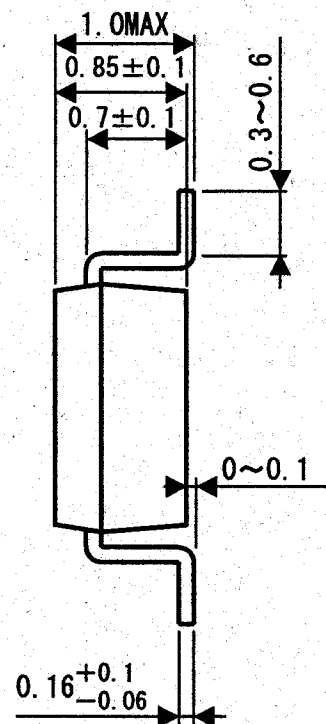
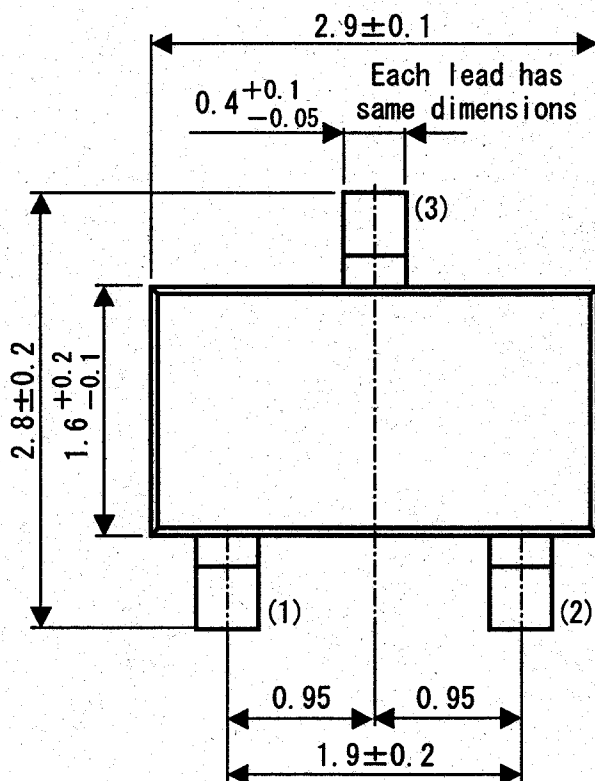

UNIT : mm

mass about 12.0mg/pcs.

- (1) Base (Gate)
- (2) Emitter (Source)
- (3) Collector (Drain)

DESIGN	CHECK	APPROVAL	DATE: JAN. 16. 2003	SPECIFICATION No. : TSQ03120
<i>Y. Mitsusaka</i>		<i>M. Maeda</i>	REV. 1	ROHM CO., LTD.

1.Scope This specification covers the tape packing requirements for Thin Super Minimold Transistors 3pin (The package style is TSMT3). For individual transistors the applicable specification shall be refer to.

2.Components description of TSMT3

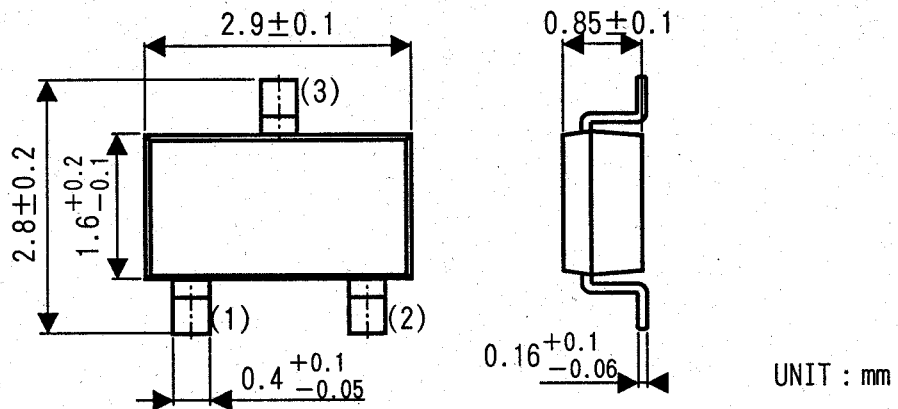

Note) The applicable specification describes in detail for individual transistors. This figure is only for reference.

3.Taping dimensions

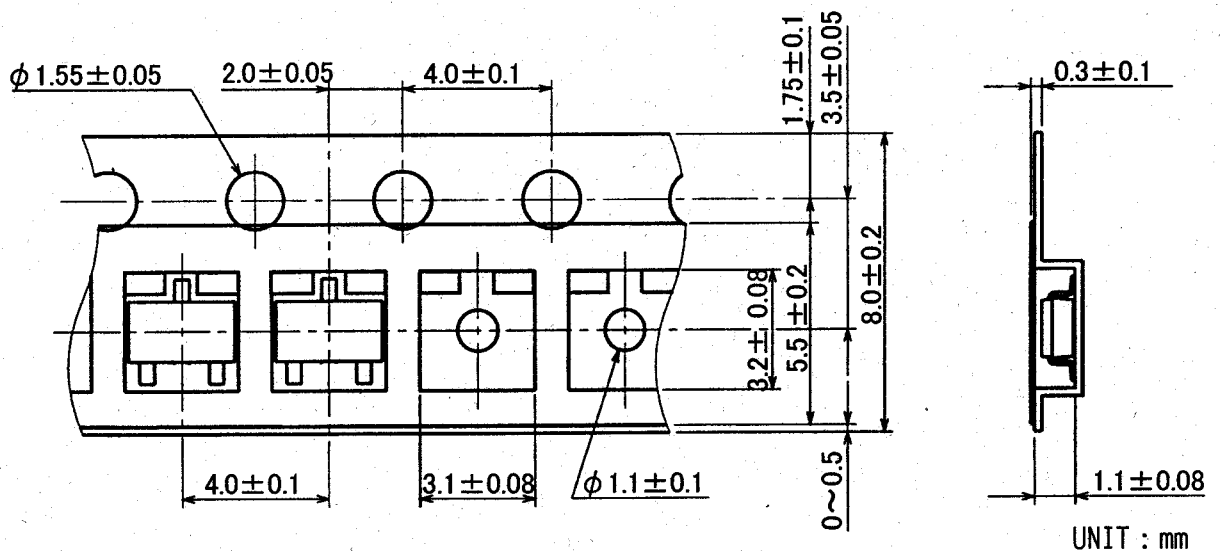

Note) Feed holes might be cover with the adhesive tape, but nothing will affect for using by that.

DESIGN	CHECK	APPROVAL	DATE: SEP. 11. 2002	SPECIFICATION No. : TSU03201-49
<i>y. Matsuoka</i>	<i>M. Maeda</i>	<i>K. Azuma</i>	REV. A	ROHM CO., LTD.

4. Taping packing specification4-1. Direction of tape winding

TL Connection (3) comes to feeding hole side.
The direction shall be one in a reel.

4-2. Cumulative pitch tolerance

The cumulative pitch tolerance of the mold for producing the carrier tape shall be within $\pm 0.2\text{mm}$ per 10 pitches.

4-3. The minimum radius to bend the carrier tape

Carrier tape shall be flexible enough to protect from no component and damage under a minimum radius of 30mm. However, it shall be defined only inside of carrier tape.

4-4. The material of carrier tape.

Special carbon paints are coated both sides of polystyrene.

4-5. Failure Rate

	Rate of occurrence	Remarks
Continuous missing	0%	Except leader and trail portion
Uncontinuous missing	MAX 0.1%/reel	

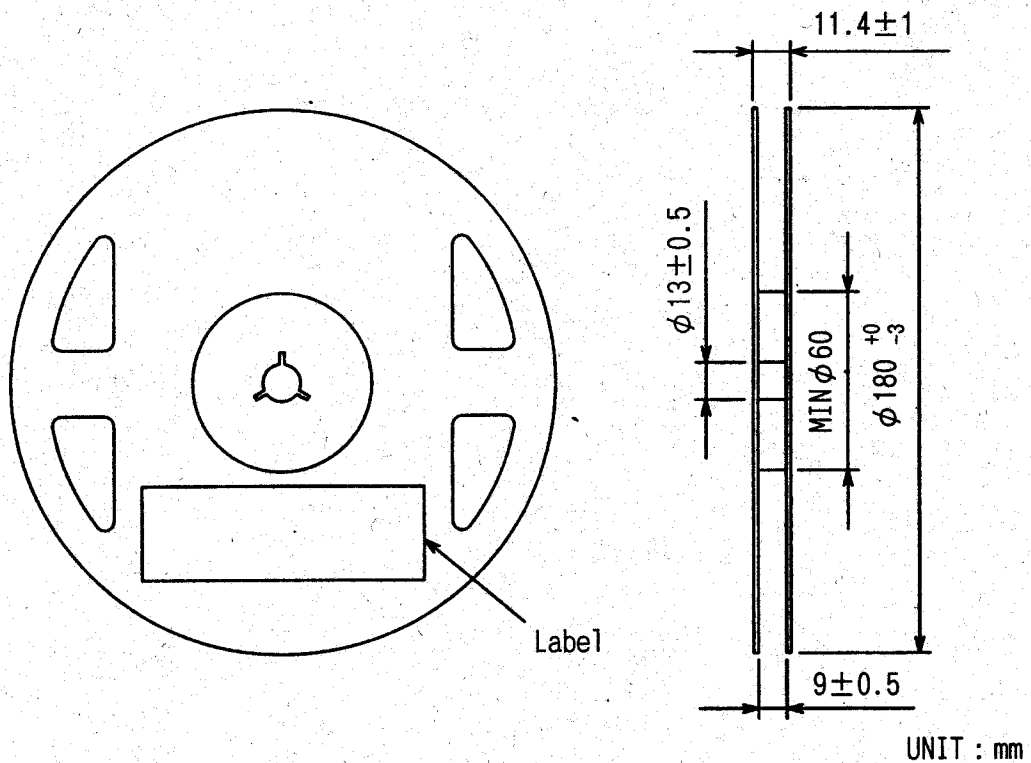
5. Reel dimensions6. Reeling specification6-1. Leading direction

Leading direction of carrier tape shall be indicated as below.

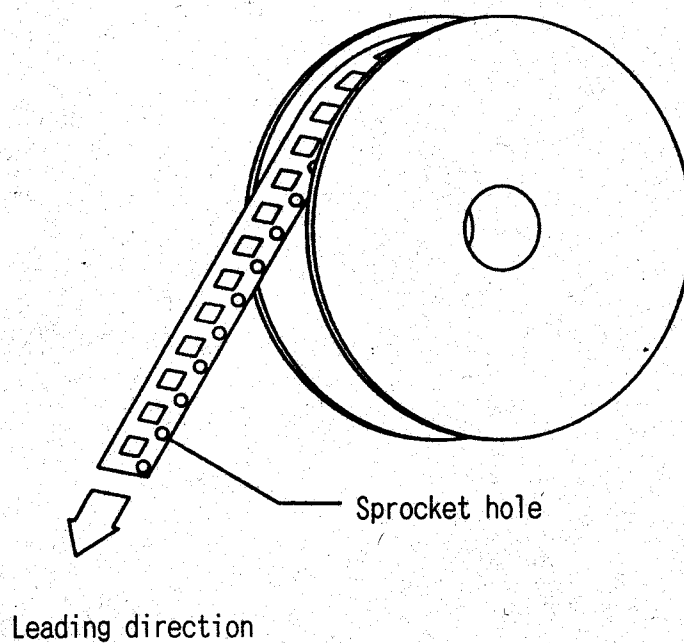

6-2. Leader

Leader tape shall be separated into two parts—an adhesive tape at first part and carrier tape without products.

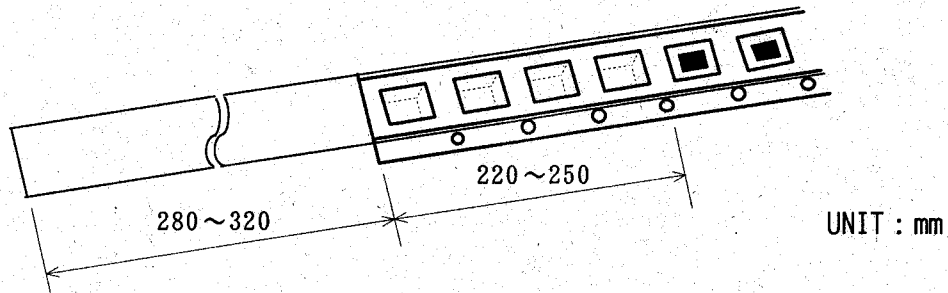

6-3. Trail

Trail tape shall remain with no product and trail tape shall not be stucked directly on a reel.

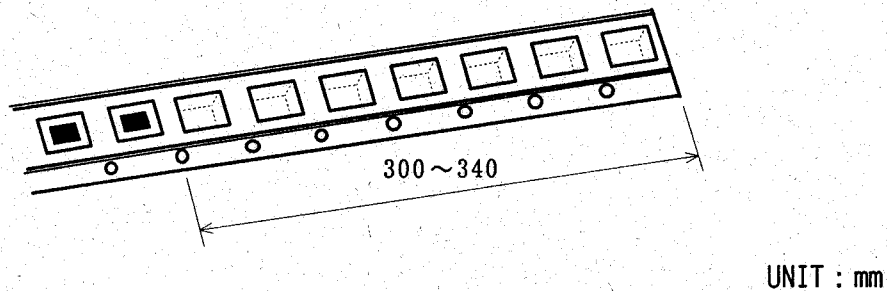

7. Treatment for end of tape

The end of leader tape shall be fixed with the white adhesive tape.

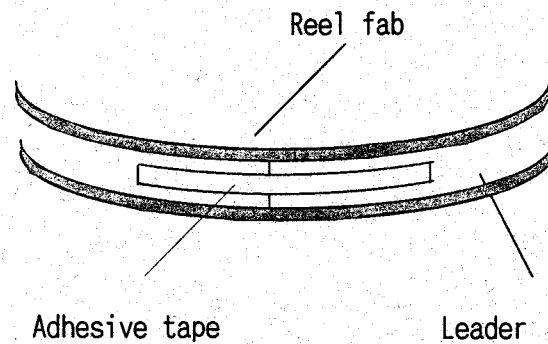

Looking for pricing, stock, or lifecycle information?

Click below to explore more details on WIN SOURCE:

- [View RTR030P02TL on WIN SOURCE](#)
- [Rohm Semiconductor Information](#)

Optimize Your Supply Chain with WIN SOURCE Solutions

- ✓ Global Sourcing Solution
- ✓ Obsolete Management
- ✓ Cost Control Management
- ✓ Shortage Management
- ✓ Alternative Solution
- ✓ Excess Inventory Management