



THE DATASHEET OF
71M6601-ILR/F



GENERAL DESCRIPTION

The 71M6103/71M6113/71M6201/71M6203/71M6601/71M6603 (71M6xxx) isolated sensor ICs enable Maxim Integrated's 4th-generation polyphase-metering 71M654x systems-on-chips (SoCs) to use nonisolating sensors such as resistive shunts without the need for costly and nonlinear isolation transformers or CTs. Isolation is provided by low-cost pulse transformers that form a bidirectional digital communication link between the 71M654x and the isolated sensor ICs.

The 71M6xxx isolated sensor ICs contain a 22-bit delta-sigma ADC, an amplifier with differential inputs, a precision voltage reference, a temperature sensor, and a supply voltage generator that is energized by power pulses provided by the 71M654x.

In conjunction with the 71M654x metering SoCs, the isolated sensor ICs offer unprecedented BOM cost reduction, immunity to magnetic tampering, and enhanced reliability for single-phase and polyphase applications.

These metering SoCs operate over the industrial temperature range and are available in an 8-pin lead(Pb)-free SO package.

BENEFITS AND FEATURES

- Reduce BOM by Replacing Expensive Current Transformers with Current Shunts
 - Compatible with Shunt Resistors as Low as 50 $\mu\Omega$
- Accurate Measurement
 - 22-Bit ADC
 - On-Chip Power Monitoring
 - Exceeds IEC 62053/ANSI C12.20 Standards
- Galvanic Isolation Through Pulse Transformer Provides Power, Bidirectional Data, and Timing Reference
 - 3.3mW Typical Consumption
 - On-Chip Power Monitoring

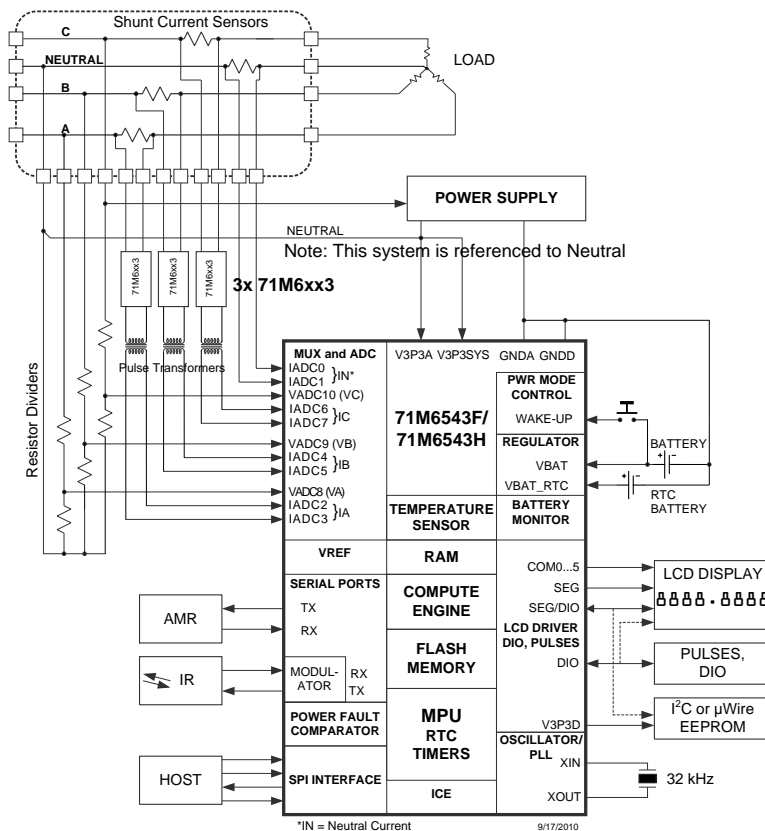

Table of Contents

| | | |
|------------|--|-----------|
| 1 | Hardware Description | 4 |
| 2 | Functional Description | 4 |
| 3 | Applications Information | 5 |
| 3.1 | Product Selection | 5 |
| 3.2 | External Components for the 71M6xxx | 6 |
| | 3.2.1 Current Sensor Side | 6 |
| | 3.2.2 Pulse Transformer | 6 |
| 3.3 | Connections to Sensors and to the 71M654x | 7 |
| 3.4 | PCB Layout Considerations | 9 |
| 3.5 | Compatibility with the 71M654x | 10 |
| 4 | Specifications | 11 |
| 4.1 | Absolute Maximum Ratings | 11 |
| 4.2 | Recommended External Components | 11 |
| 4.3 | Recommended Operating Conditions | 11 |
| 4.4 | Performance Specifications | 12 |
| | 4.4.1 Supply Current | 12 |
| | 4.4.2 Power and Data Pulses | 12 |
| | 4.4.3 VCC Voltage Monitor | 12 |
| | 4.4.4 Temperature Sensor | 12 |
| | 4.4.5 VREF Performance Specifications | 13 |
| | 4.4.6 ADC Converter..... | 14 |
| 4.5 | Typical Performance Data | 15 |
| 4.6 | Package Outline Drawing | 16 |
| 4.7 | IC Pinout | 17 |
| 4.8 | Pin Description | 17 |
| 5 | Ordering Information | 18 |
| 6 | Related Information | 18 |
| 7 | Contact Information | 18 |

List of Figures

| | |
|--|----|
| Figure 1: Block Diagram..... | 4 |
| Figure 2: External Components Connected to the 71M6xxx | 7 |
| Figure 3: Current Sensors Connected to the 71M6541D/F Using One 71M6x01 | 8 |
| Figure 4: Current Sensors Connected to the 71M6543F/H or 71M6545/H with Three 71M6xx3..... | 9 |
| Figure 5: Copper Separation and Signal Traces for a Polyphase PCB..... | 10 |
| Figure 6: Wh Error at Room Temperature (71M6203, 100A/0.1A, 60Hz/240V AC)..... | 15 |
| Figure 7: VARh Error at Room Temperature (71M6203, 100A/0.1A, 60Hz/240V AC)..... | 15 |
| Figure 8: SOIC-8 Package Outline | 16 |
| Figure 9: Pinout for 8-Pin SO Package..... | 17 |

List of Tables

| | |
|---|----|
| Table 1: Remote Interface Commands | 5 |
| Table 2: Product Variations..... | 6 |
| Table 3: Absolute Maximum Ratings | 11 |
| Table 4: Recommended External Components | 11 |
| Table 5: Recommended Operating Conditions..... | 11 |
| Table 6: Supply Current Performance Specifications | 12 |
| Table 7: Timing Specifications for Power and Data Pulses | 12 |
| Table 8: VCC Voltage Monitor Specifications | 12 |
| Table 9: Temperature Sensor Specifications..... | 12 |
| Table 10: VREF Performance Specifications..... | 13 |
| Table 11: ADC Converter Specifications | 14 |
| Table 12: Pin Description | 17 |
| Table 13: Product Variations..... | 18 |
| Table 14: Packaging Information, Corresponding CE Codes, and Ordering Numbers | 18 |

1 HARDWARE DESCRIPTION

The 71M6103/71M6113/71M6201/71M6203/71M6601/71M6603 (71M6xxx) remote sensor ICs integrate all functional blocks required to implement an isolated front-end with digital communication capability. Figure 1 shows the 71M6xxx IC block diagram. The chip includes the following:

- Preamplifier with a fixed gain
- 22-bit delta-sigma ADC
- ADC voltage reference
- Temperature sensor
- VCC monitor
- Power-on reset circuitry
- Bidirectional pulse interface
- Active rectifiers for supply-voltage generation from the power pulses provided by the 71M654x
- Digital control section providing control registers for the selection of operation modes

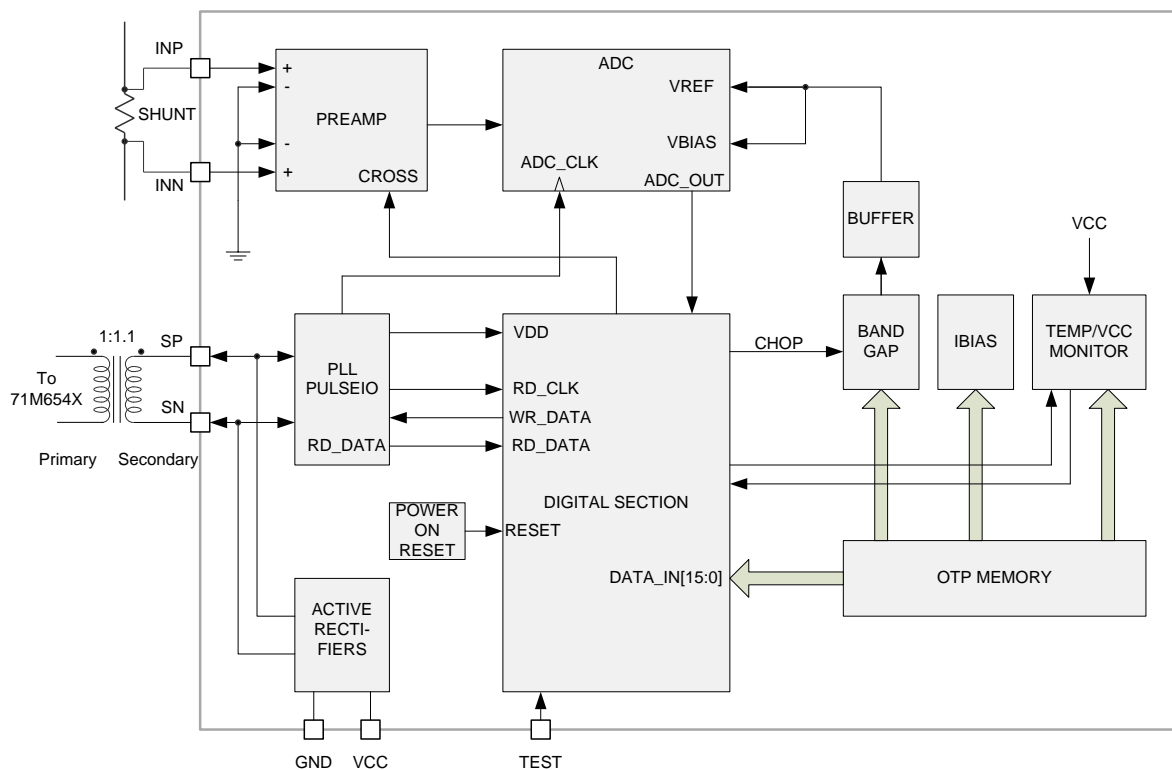

Figure 1: Block Diagram

2 FUNCTIONAL DESCRIPTION

During normal operation, the SP and SN pins of the 71M6xxx are connected to the pulse transformer. When $PLL_FAST = 1$ in the 71M654x, power pulses generated by the 71M654x arrive every 610.35ns. The PLL in the 71M6xxx locks to these incoming power pulses. The communication between the 71M654x and the 71M6xxx is synchronized to the multiplexer frames of the 71M654x. The communication protocol is Maxim Integrated-proprietary, and details are not described in this data sheet. All aspects of the communication between the 71M654x and the 71M6xxx are managed on the hardware level and they are completely transparent to the user.

The communication interface can run at two different data rates. Power pulses are generated every 610.35ns if the PLL_FAST register in the 71M654x is set to 1, and every 1.905 μ s if PLL_FAST is set to 0. The power pulses are 101.7ns wide with $PLL_FAST = 1$, and 160ns wide with $PLL_FAST = 0$.

The 71M6xxx isolated sensors provide a continuous data stream of ADC data plus an independent data stream that contains auxiliary information as requested by the 71M654x. The ADC data is processed by CE code in the 71M654x and stored in CE RAM. Auxiliary information is processed by the MPU of the 71M654x using I/O RAM registers.

Basic settings and functions of the 71M6xxx can be controlled by various I/O RAM registers in the 71M654x. The command sent towards the 71M6xxx is placed in the *RCMD[4:2]* register of the 71M654x, with further specification contained in the *TMUXRn[2:0]* register. Refer to the 71M654x data sheets for details.

Table 1 shows the allowable combinations of values in *RCMD[4:2]* and *TMUXRn[2:0]*, and the achieved operation along with the type and format of data sent back by the 71M6xxx isolated sensors.

Table 1: Remote Interface Commands

| <i>RCMD[4:2]</i> | <i>TMUXRn[2:0]</i> | Read Operation/Command | <i>R6K_RD [15:0]</i> |
|------------------|--------------------|--------------------------------------|--|
| 001 | 00X | Chip-characteristic temperature data | <i>TRIMT</i> (see note), use bits [8:1] |
| 001 | 01X | | <i>TRIMBGC</i> (see note), use bits [15:6] |
| 001 | 10X | | <i>TRIMBGA</i> (see note), use bits [15:8] |
| 001 | 11X | | <i>TRIMBGB</i> bits [15:8], <i>TRIMBGD</i> bits [7:0] (see note) |
| 010 | 00X | Temperature | Output of the temperature sensor, bits [10:0] |
| 010 | 01X | Supply voltage | Supply voltage measurement, bits [7:0] |
| 010 | 10X | Chip version | Chip version code, use bits [15:8] |
| 110 | 111 | Reset | — |

Note: *TRIMBGA* to *TRIMBGD* and *TRIMT* are values used for characterizing the individual 71M6xxx over temperature. Availability of *TRIMBGA* to *TRIMBGD* and *TRIMT* depends on the part number (see [Table 10](#) for details).

The remote interface commands listed in [Table 1](#) enable the 71M654x to gather the following information from the 71M6xxx:

- Output of the temperature sensor
- Information on how the device is characterized over temperature
- Supply voltage
- Chip version code

The control commands listed in [Table 1](#) enable the 71M654x to initiate the following actions in the 71M6xxx:

- Read the 71M6xxx temperature sensor
- Read the 71M6xxx VCC sensor
- Hardware reset

With hardware and temperature characterization information on each connected 71M6xxx isolated sensor available to the 71M654x host MPU, temperature compensation of the energy measurement can be implemented based on the individual temperature characteristics of the 71M6xxx isolated sensors. For example, when the 71M6xxx are used in a polyphase meter containing three shunt resistors, the temperature increase in each 71M6xxx can be monitored and used to compensate for the temperature coefficient of the 71M6xxx VREF and the corresponding shunt resistor.

3 APPLICATIONS INFORMATION

3.1 Product Selection

A low-noise differential-input preamplifier applies gain to the signal from the current sensor to the optimal input range of the ADC. The current sensor is connected to the inputs of the preamplifier through INP and INN. The output of the preamplifier connects directly to the input of the ADC. See [5 Ordering Information](#) for available part types. Shunt resistances from 736 $\mu\Omega$ to as low as 50 $\mu\Omega$ can be accommodated, depending on desired current range and part type.

The shunt resistance must be balanced with the maximum current range of the part type, as shown in [Table 2](#). Various combinations of current ranges and shunt resistance values are possible. However, the shunt resistance for a given current has to be chosen carefully as not to exceed the maximum RMS voltage at the INP/INN pins of the 71M6xxx. The maximum wattage of the shunt resistor is another consideration that applies to the resistance range of the shunt.

Table 2: Product Variations

| Part | Application ¹ | Maximum Current (A) | Accuracy Class ² (%) | Maximum RMS Voltage at INP/INN (mV) | Maximum Shunt Resistance ³ ($\mu\Omega$) | Shunt Power ⁴ (W) | Typical Shunt Resistance ⁵ ($\mu\Omega$) |
|---------|--------------------------|---------------------|---------------------------------|-------------------------------------|---|------------------------------|---|
| 71M6601 | S | 60 | 1 | 44 | 736 | 1.44 | 400 |
| 71M6603 | P | | 1 | | | | |
| 71M6103 | P | 100 | 1 | 19.6 | 196 | 1.2 | 120 |
| 71M6113 | | | 0.5 | | | | |
| 71M6201 | S | 200 | 0.2 | 12.6 | 63 | 2.0 | 50 |
| 71M6203 | P | | 0.2 | | | | |

Note 1: S = single phase, P = polyphase.
Note 2: Accuracy over temperature (-40°C to +85°C for 71M620x parts, -20°C to +60° for all other parts), when combined with 71M654x or 71M654xH IC.
Note 3: Maximum resistance at maximum current.
Note 4: Power at maximum current and typical shunt resistance.
Note 5: Typical resistance values provide room for overhead while maintaining optimum dynamic range.

The inputs of the preamplifier are referenced to local ground (the GND pin of the 71M6xxx). This means that in an isolated system, the INP and INN pins have to be biased towards this local GND. See [3.2.1 Current Sensor Side](#) for details.

3.2 External Components for the 71M6xxx

3.2.1 Current Sensor Side

[Figure 2](#) shows the external components required for the 71M6xxx. It is recommended to use the following components:

- 1.0 μ F capacitor between the GND and VCC pins. This capacitor minimizes the VCC ripple voltage.
- One 1k Ω resistor each from the sensor output pins to GND. These resistors help to bias the input voltage at the INP and INN pins towards GND.
- In environments where EMC is a concern, ferrite beads can be placed between the sense pins of the shunt resistor and the INP/INN pins of the 71M6xxx.

3.2.2 Pulse Transformer

A low-cost pulse transformer is used for the link between the 71M654x and the 71M6xxx. It is the responsibility of the meter system designer to qualify the transformer used in the system over the required operating temperature range. The following commercially available transformer is suitable for this application:

- Würth Electronics Midcom Inc., P/N 750-11-0056 REV 2 (www.midcom-inc.com)

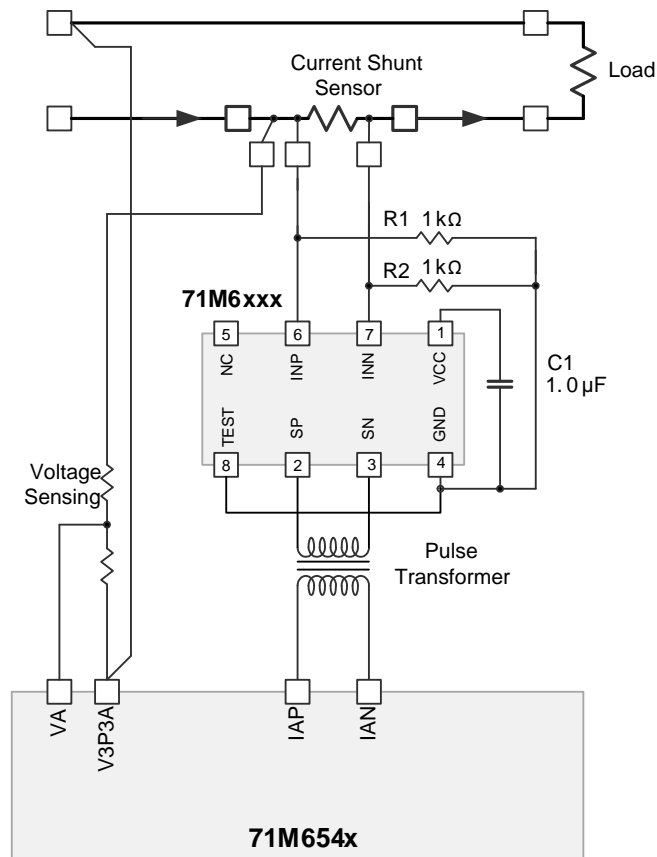

Figure 2: External Components Connected to the 71M6xxx

3.3 Connections to Sensors and to the 71M654x

Figure 3 shows the sensor connections for single-phase meter application using a 71M6541D/F and 71M6x01. This single-phase configuration uses one local shunt and one shunt isolated with a 71M6x01 device. Since the local shunt is connected to the LINE circuit, the meter is also referenced to the LINE circuit.

Figure 4 shows the sensor connections for a polyphase meter application using a 71M6543F/H or 71M6545/H. This polyphase configuration uses three 71M6xx3 to isolate the shunt sensors for the three phases, while a locally connected fourth shunt sensor can be optionally used to sense neutral current. Since the local shunt is connected to the neutral circuit, the meter is also referenced to the neutral circuit.

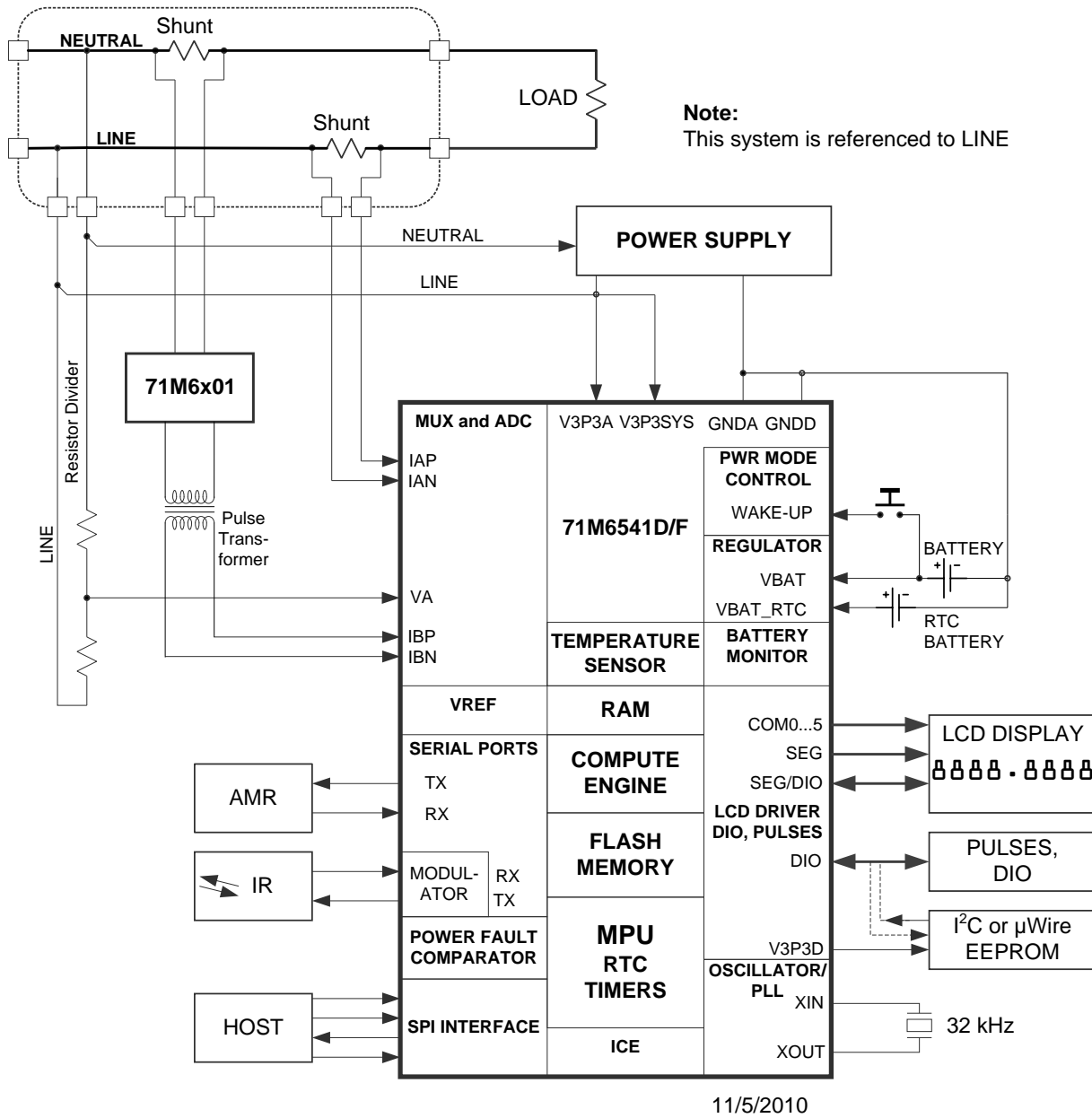

Figure 3: Current Sensors Connected to the 71M6541D/F Using One 71M6x01

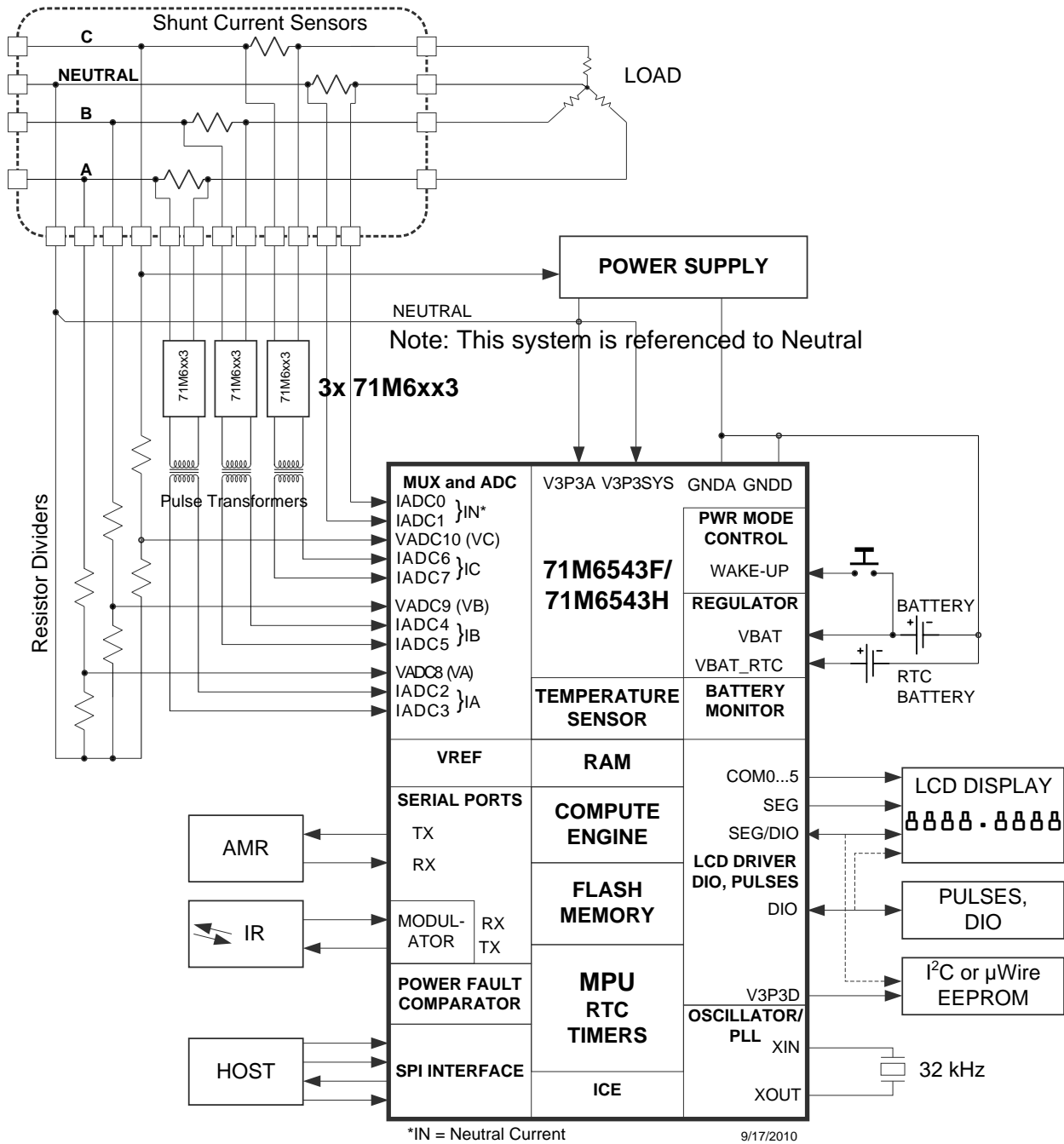

Figure 4: Current Sensors Connected to the 71M6543F/H or 71M6545/H with Three 71M6xx3

3.4 PCB Layout Considerations

To limit emissions and susceptibility to electromagnetic and magnetic fields, the signal wiring between the shunt resistors and the 71M6xxx should be as short as possible and should consist of tightly twisted pair cable. Similarly, the PCB traces between the 71M6xxx and the 71M654x should be routed as short as possible and should be surrounded by grounded copper structures. The trace pairs should be routed as close to each other as permitted by the PCB manufacturer.

The copper separation (gap) between the shunt side and the 71M654x side of the signal transformer should be as wide as permitted by the footprint of the transformer, as shown in Figure 5.

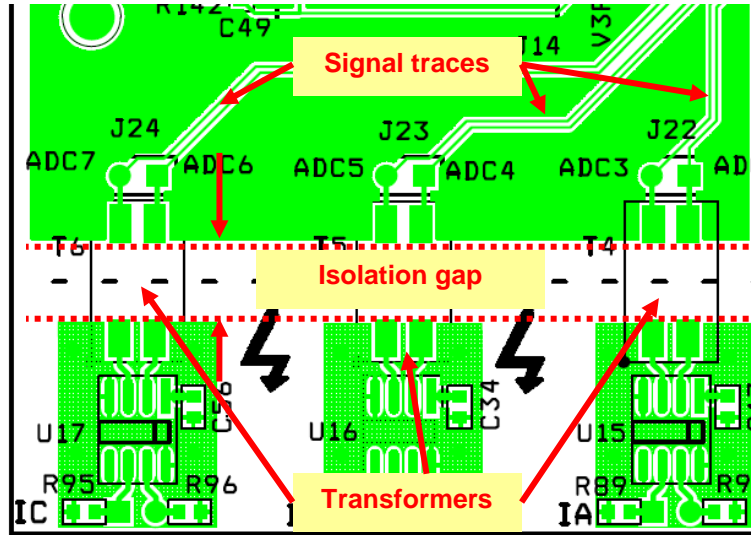

Figure 5: Copper Separation and Signal Traces for a Polyphase PCB

3.5 Compatibility with the 71M654x

The 71M6xxx isolated sensor ICs are designed to be operated in conjunction with the 71M654x energy-metering ICs. Operation of the 71M6xxx isolated sensor ICs requires a 71M654x IC with CE code capable of interfacing with the 71M6xxx. CE codes written for operation with CTs do not work with the 71M6xxx.

The 71M6xxx isolated sensor ICs are not arbitrarily interchangeable. Each type of the 71M6xxx must be matched with its corresponding CE code in the 71M654x per [Table 14](#). A 71M6xxx remote sensor IC generates unpredictable results when paired with a CE code for a different part number. All 71M6xxx isolated sensor ICs used in a polyphase system must be of the same part number.

4 SPECIFICATIONS

4.1 Absolute Maximum Ratings

Table 3 shows the absolute maximum ranges for the device. Stresses beyond Absolute Maximum Ratings may cause permanent damage to the device. These are stress ratings only and functional operation at these or any other conditions beyond those indicated under recommended operating conditions (4.3 Recommended Operating Conditions) is not implied. Exposure to absolute maximum ratings conditions for extended periods may affect device reliability. All voltages are with respect to GND.

Table 3: Absolute Maximum Ratings

| SUPPLIES AND GROUND PINS: | |
|--|--|
| VCC | -0.5V to 4.6V |
| GND | -0.1V to +0.1V |
| ANALOG INPUT PINS: | |
| INP, INN, SP, SN | -10mA to +10mA, -0.5V to (VCC + 0.5V) |
| TEMPERATURE: | |
| Operating Junction Temperature (Peak, 100ms) | +140°C |
| Operating Junction Temperature (Continuous) | +125°C |
| Storage Temperature Range | -45°C to +165°C |
| Soldering Temperature (10s duration) | +250°C |

4.2 Recommended External Components

Table 4: Recommended External Components

| NAME | FROM | TO | FUNCTION | VALUE | UNITS |
|--------|--------|-----|---|-------|-------|
| C1 | VCC | GND | Bypass capacitor for supply | 1.0 | μF |
| R1, R2 | Sensor | GND | To establish proper bias for INP/INN pins | 1 | kΩ |

4.3 Recommended Operating Conditions

Table 5: Recommended Operating Conditions

| PARAMETER | CONDITIONS | MIN | TYP | MAX | UNITS |
|-----------------------------|------------|-----|-----|-----|-------|
| VCC Supply Voltage | | 2.5 | | 3.6 | V |
| Operating Temperature Range | | -40 | | +85 | °C |

4.4 Performance Specifications

Unless otherwise specified, all parameters listed in this section are valid over the Recommended Operating Conditions provided in [Table 5](#).

4.4.1 Supply Current

Table 6: Supply Current Performance Specifications

| PARAMETER | CONDITIONS | MIN | TYP | MAX | UNITS |
|-------------------------------|------------|-----|------|------|-------|
| VCC Current, Normal Operation | VCC = 3.3V | | 0.77 | 1.05 | mA |

4.4.2 Power and Data Pulses

Table 7: Timing Specifications for Power and Data Pulses

| PARAMETER | CONDITIONS | MIN | TYP | MAX | UNITS |
|-----------------|--------------------------------|-----|--------|-----|-------|
| Pulse Frequency | Normal operation | | 1.638 | | MHz |
| | 71M654x (<i>PLL_FAST</i> = 0) | | 0.5249 | | |

4.4.3 VCC Voltage Monitor

Table 8: VCC Voltage Monitor Specifications

| PARAMETER | CONDITIONS | MIN | TYP | MAX | UNITS |
|---|--|-----|-----|-----|-------|
| BNOM: Nominal Value, $T_A = +22^\circ\text{C}$ | VCC = 3.2V | | 138 | | LSB |
| VCC Voltage (Note: This is a definition—it is not a measured quantity.) | $VCC = 3.195 + (\text{BSENSE} - 138) \times 0.0246 + \text{STEMP} \times 0.000104$ | | | | V |
| BE: Measurement Error $VCC = 3.195 + (\text{BSENSE} - 138) \times 0.0246 + \text{STEMP} \times 0.000104$ | VCC = 2.5V | -5 | | +5 | % |
| | VCC = 2.8V to 3.6V | -5 | | +5 | |

4.4.4 Temperature Sensor

Table 9: Temperature Sensor Specifications

| PARAMETER | CONDITIONS | MIN | TYP | MAX | UNITS |
|--|--|---------------------------|------|------|------------------|
| TNOM: Nominal Value, $T_A = +22^\circ\text{C}$ | VCC = 3.2V | | 870 | | LSB |
| Temperature Equation for: 71M6601, 71M6603, 71M6103 and 71M6113 (Note: This is a definition—it is not a measured quantity.) | $\text{TEMP} = \text{STEMP} \times 0.33 - \text{STEMP}^2 \times 3\text{E-}5 + 22$ | | | | $^\circ\text{C}$ |
| Temperature Equation for: 71M6201 and 71M6203 (Note: This is a definition—it is not a measured quantity.) | If $\text{STEMP} < 0$: $\text{TEMP} = \text{STEMP} \times 0.33 - \text{STEMP}^2 \times 3\text{E-}5 + 22$ If $\text{STEMP} \geq 0$: $\text{TEMP} = \text{STEMP} \times (63 / \text{TRIMBGA}) + 22$ | | | | $^\circ\text{C}$ |
| Temperature Error (Note 1) | Temperature = -40 $^\circ\text{C}$, -10 $^\circ\text{C}$, +55 $^\circ\text{C}$, +85 $^\circ\text{C}$ | VCC = 2.8V to 3.6V | -5 | +5 | $^\circ\text{C}$ |
| | | VCC = 2.5V to 2.79V | -6.5 | +6.5 | |
| TETIME: Duration of Temperature Measurement | VCC = 3.0V | | 15 | 30 | ms |

Note 1: Guaranteed by design; not production tested.

4.4.5 VREF Performance Specifications

Table 10 shows the performance specifications for the ADC reference voltage (VREF).

Table 10: VREF Performance Specifications

| PARAMETER | CONDITIONS | MIN | TYP | MAX | UNITS |
|--|--|-------|-------|-------|--------------------|
| VREF Output Voltage | 71M6201, 71M6203, 71M6113: T _A = +22°C | 1.193 | 1.195 | 1.197 | V |
| | 71M6601, 71M6603, 71M6103: T _A = +22°C | 1.180 | 1.195 | 1.210 | |
| VREF Output Impedance | I _{LOAD} = 10μA, -10μA on TMUXOUT | | 8 | | kΩ |
| VREF Power-Supply Sensitivity: ΔVREF/ΔVCC | VCC = 2.8V to 3.6V | -1.5 | | +1.5 | mV/V |
| | VCC = 2.5V to 3.6V | -2 | | +2 | |
| VREF Chop Step (Trimmed) | VREF(CROSS = 1) - VREF(CROSS = 0) | -22 | 0 | +22 | mV |
| VNOM Definition | VNOM(T) = VREF(22) + (T - 22)TC1 + (T - 22) ² TC2 | | | | V |
| 71M6201 AND 71M6203 (0.2% ACCURACY CLASS) | | | | | |
| VNOM Temperature Coefficients: TC1, TC2 | TC1 = 0.0538 x TRIMT + 1.587(TRIMBGB - TRIMBGD) + 27.279 | | | | μV/°C |
| | TC2 = -0.433 - TRIMT x 0.000854 | | | | μV/°C ² |
| VREF(T) Deviation from VNOM(T) (Note 1) | $\frac{VREF(T) - VNOM(T)}{VNOM(T)} \frac{10^6}{62}$ | -15 | | +15 | ppm/°C |
| 71M6113 (0.5% ACCURACY CLASS) | | | | | |
| VNOM Temperature Coefficients: TC1, TC2 | TC1 = 251 - TRIMT x 4.60 | | | | μV/°C |
| | TC2 = -0.433 - TRIMT x 0.000854 | | | | μV/°C ² |
| VREF(T) Deviation from VNOM(T) (Note 1) | $\frac{VREF(T) - VNOM(T)}{VNOM(T)} \frac{10^6}{62}$ | -50 | | +50 | ppm/°C |
| 71M6601, 71M6603, AND 71M6103 (1% ACCURACY CLASS) | | | | | |
| VNOM Temperature Coefficients: TC1, TC2 | TC1 = -34.8 | | | | μV/°C |
| | TC2 = -0.599 | | | | μV/°C ² |
| VREF(T) Deviation from VNOM(T) (Note 1) | $\frac{VREF(T) - VNOM(T)}{VNOM(T)} \frac{10^6}{45}$ | -100 | | +100 | ppm/°C |

Note 1: Guaranteed by design; not production tested.

4.4.6 ADC Converter

Table 11: ADC Converter Specifications

| PARAMETER | CONDITIONS | | MIN | TYP | MAX | UNITS |
|--------------------------|--|-----|-----|-----|-----|---------------|
| Input Current | INP and INN at GND potential | INP | | 22 | | μA |
| | | INN | | 22 | | |
| THD (First 10 Harmonics) | VIN = 65Hz, 64kpts FFT, Blackman-Harris window | | | -85 | | dB |

4.5 Typical Performance Data

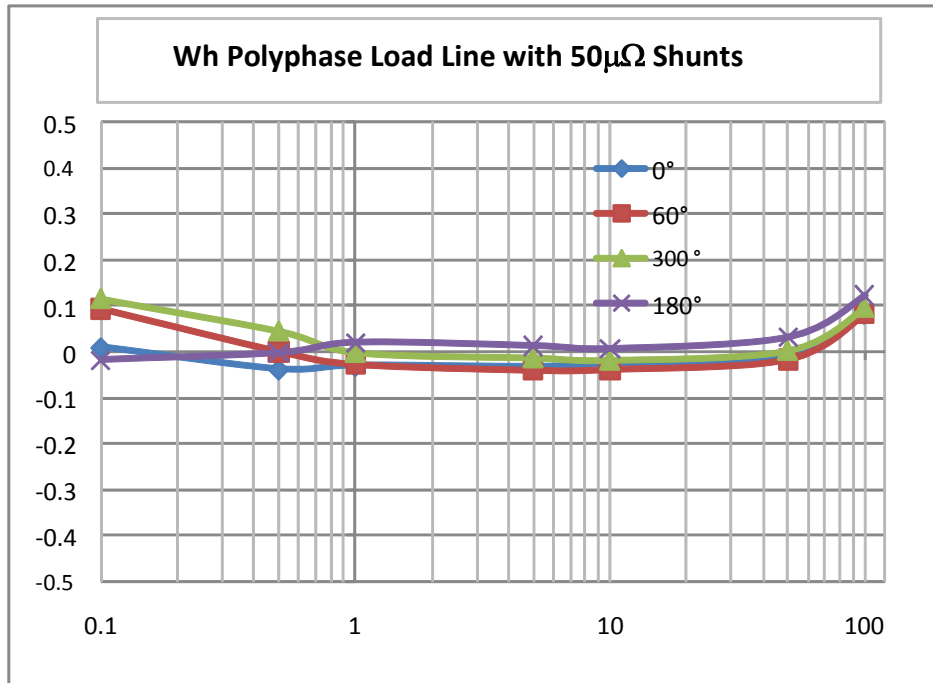

Figure 6: Wh Error at Room Temperature (71M6203, 100A/0.1A, 60Hz/240V AC)

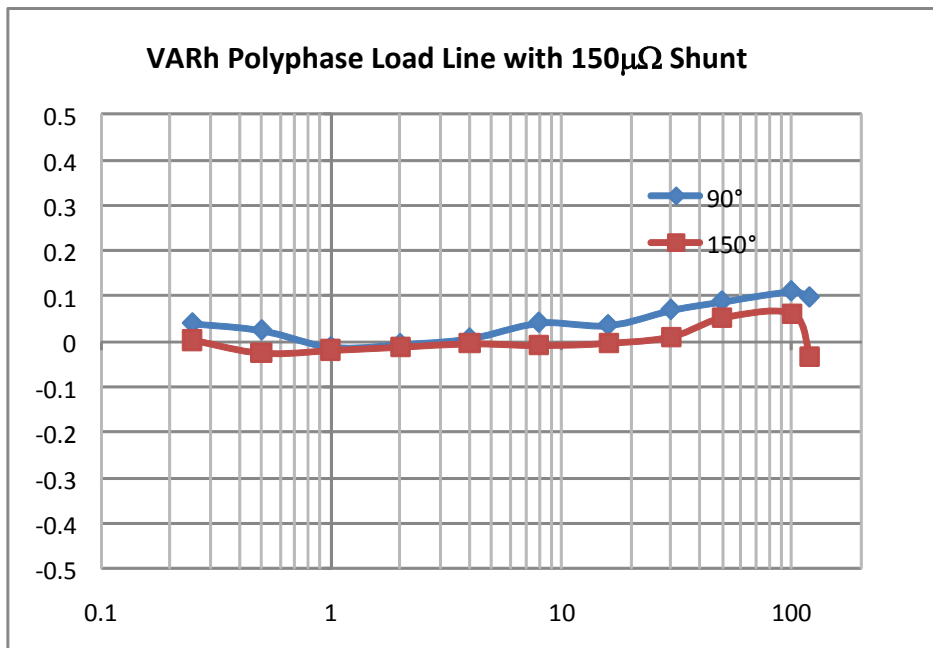
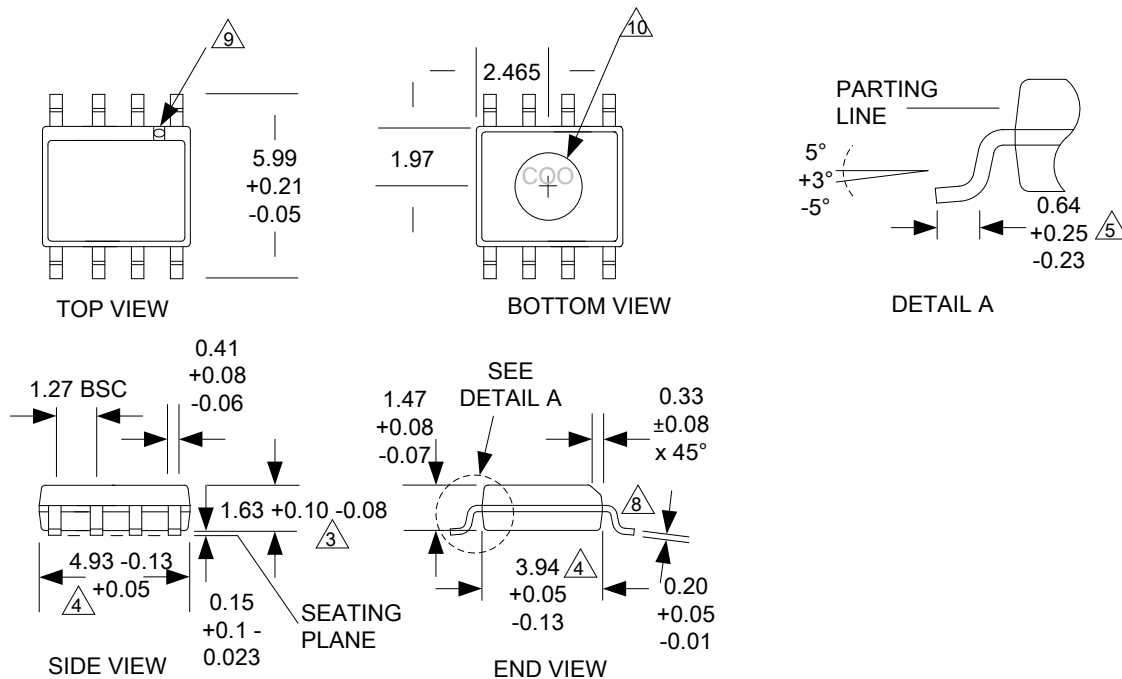

Figure 7: VARh Error at Room Temperature (71M6203, 100A/0.1A, 60Hz/240V AC)

4.6 Package Outline Drawing

Controlling dimensions are in mm.



NOTES:

- △3 REFERENCE DATUM
- △4 LENGTH AND WIDTH ARE REFERENCE DATUMS AND DO NOT INCLUDE MOLD FLASH OR PROTRUSIONS, BUT INCLUDE MOLD MISMATCH. MEASURED AT THE MOLD PARTING LINE. PROTRUSIONS DO NOT EXCEED 0.1524 mm AT END AND 0.254 mm AT WINDOW.
- △5 LENGTH OF TERMINAL FOR SOLDERING TO SUBSTRATE
- △8 FORMED LEADS ARE PLANAR WITH RESPECT TO EACH OTHER WITHIN 0.735 mm AT SEATING PLANE.
- △9 THE APPEARANCE OF PIN #1 I.D. IS OPTIONAL.
- △10 COUNTRY OF ORIGIN LOCATION ON PACKAGE BOTTOM IS OPTIONAL AND DEPENDS ON ASSEMBLY LOCATION.

PACKAGE IS COMPLIANT WITH JEDEC STANDARD MS-012.
DIMENSIONING AND TOLERANCES PER ANSI Y14.5 M - 1982

Figure 8: SOIC-8 Package Outline

4.7 IC Pinout

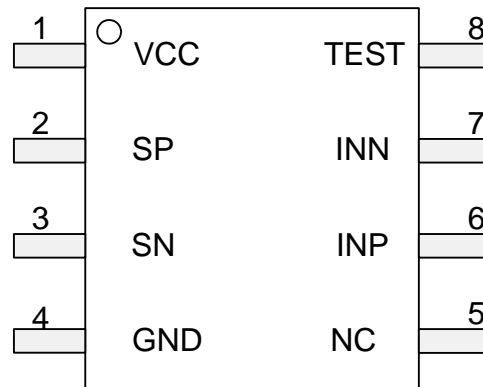

Figure 9: Pinout for 8-Pin SO Package

4.8 Pin Description

Table 12: Pin Description

| PIN | NAME | FUNCTION |
|-----|------|---|
| 1 | VCC | Supply Voltage Output. A 1.0 μ F capacitor to GND should be provided. |
| 2 | SP | Positive Bidirectional Communication Port for the Connection of the Pulse Transformer |
| 3 | SN | Negative Bidirectional Communication Port for the Connection of the Pulse Transformer |
| 4 | GND | Ground (Local Ground). The voltage at the INP and INN pins references to this pin. |
| 5 | NC | No Connection. No connections must be made to this pin. |
| 6 | INP | Positive Analog Input from Sensor. This input must be biased towards GND with a 1k Ω resistor. |
| 7 | INN | Negative Analog Input from Sensor. This input must be biased towards GND with a 1k Ω resistor. |
| 8 | TEST | Input Used in Factory for Test Purposes. This pin must be connected to GND. |

5 ORDERING INFORMATION

Table 13: Product Variations

| PART | APPLICATION | RATED CURRENT (A) | MAX INPUT VOLTAGE AT INP-INN PINS (mV) | TEMP RANGE (°C) | TYP OPERATING TEMP RANGE (°C) | RECOMMENDED METER ACCURACY CLASS (%) | MAX SHUNT RESISTANCE ($\mu\Omega$) |
|---------|-------------|-------------------|--|-----------------|-------------------------------|--------------------------------------|--------------------------------------|
| 71M6601 | 1-phase | 60 | 44 | -40 to +85 | -20 to +60 | 1 | 736 |
| 71M6603 | 3-phase | | | | | | |
| 71M6103 | 3-phase | 100 | 19.6 | | -20 to +60 | 1 | 196 |
| 71M6113 | 3-phase | | | | | 0.5 | |
| 71M6201 | 1-phase | 200 | 12.6 | | -40 to +85 | 0.2 | 63 |
| 71M6203 | 3-phase | | | | | | |

Table 14: Packaging Information, Corresponding CE Codes, and Ordering Numbers

| PART | TEMP RANGE | PIN-PACKAGE | 71M654x CE CODE |
|----------------------|----------------|-------------|--------------------|
| 71M6601 -IL/F | -40°C to +85°C | 8 SO | EQU0-60 |
| 71M6601-ILR/F | -40°C to +85°C | 8 SO | EQU0-60 |
| 71M6603 -IL/F | -40°C to +85°C | 8 SO | EQU5-60 |
| 71M6603-ILR/F | -40°C to +85°C | 8 SO | EQU5-60 |
| 71M6103 -IL/F | -40°C to +85°C | 8 SO | EQU5-100 |
| 71M6103-ILR/F | -40°C to +85°C | 8 SO | EQU5-100 |
| 71M6113 -IL/F | -40°C to +85°C | 8 SO | EQU5-100 |
| 71M6113-ILR/F | -40°C to +85°C | 8 SO | EQU5-100 |
| 71M6201 -IL/F | -40°C to +85°C | 8 SO | EQU1-200, EQU2-200 |
| 71M6201-ILR/F | -40°C to +85°C | 8 SO | EQU1-200, EQU2-200 |
| 71M6203 -IL/F | -40°C to +85°C | 8 SO | EQU5-200 |
| 71M6203-ILR/F | -40°C to +85°C | 8 SO | EQU5-200 |

F = Lead(Pb)-free/RoHS-compliant package.

R = Tape and reel.

6 RELATED INFORMATION

The following documents related to the 71M6xxx are available from Maxim Integrated:

71M6543F/H Data Sheet

71M6541D/F-71M6542F Data Sheet

71M6545/H Data Sheet

7 CONTACT INFORMATION

For technical support or more information about Maxim Integrated products, contact technical support at www.maximintegrated.com/support.

REVISION HISTORY

| REVISION NUMBER | REVISION DATE | DESCRIPTION | PAGES CHANGED |
|-----------------|---------------|---|---------------|
| 0 | 12/10 | Initial release | — |
| 1 | 3/11 | Figure 1, page 4 (transformer turns ratio 1:1.1) Table 9, page 12 Table 14, page 18 | 4, 12, 18 |
| 2 | 6/11 | Removed future status from the 71M6113 parts in Table 14 | 18 |
| 3 | 12/12 | Removed future status from the 71M6201/71M6203 parts in Table 14 | 18 |
| 4 | 1/15 | Updated the <i>Benefits and Features</i> section | 1 |

Maxim Integrated cannot assume responsibility for use of any circuitry other than circuitry entirely embodied in a Maxim Integrated product. No circuit patent licenses are implied. Maxim Integrated reserves the right to change the circuitry and specifications without notice at any time. The parametric values (min and max limits) shown in the Electrical Characteristics table are guaranteed. Other parametric values quoted in this data sheet are provided for guidance.

Looking for pricing, stock, or lifecycle information?

Click below to explore more details on WIN SOURCE:

 [View 71M6601-ILR/F on WIN SOURCE](#)

 [Maxim Integrated](#) Information

Optimize Your Supply Chain with WIN SOURCE Solutions

-  Global Sourcing Solution
-  Obsolete Management
-  Cost Control Management
-  Shortage Management
-  Alternative Solution
-  Excess Inventory Management