



THE DATASHEET OF
7486N



DM7486

Quad 2-Input Exclusive-OR Gate

General Description

This device contains four independent gates each of which performs the logic exclusive-OR function.

Ordering Code:

Order Number	Package Number	Package Description
DM7486N	N14A	14-Lead Plastic Dual-In-Line Package (PDIP), JEDEC MS-001, 0.300" Wide

Connection Diagram

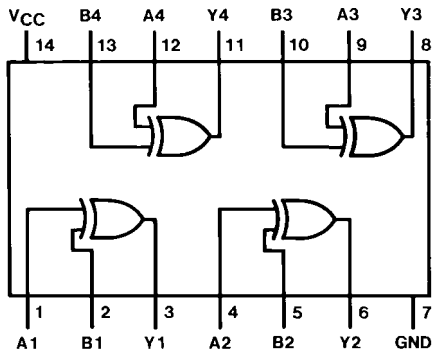

Function Table

$$Y = A \oplus B$$

Inputs		Output
A	B	Y
L	L	L
L	H	H
H	L	H
H	H	L

H = HIGH Logic Level
L = LOW Logic Level

Absolute Maximum Ratings(Note 1)

Supply Voltage	7V
Input Voltage	5.5V
Operating Free Air Temperature Range	0°C to +70°C
Storage Temperature Range	-65°C to +150°C

Note 1: The "Absolute Maximum Ratings" are those values beyond which the safety of the device cannot be guaranteed. The device should not be operated at these limits. The parametric values defined in the Electrical Characteristics tables are not guaranteed at the absolute maximum ratings. The "Recommended Operating Conditions" table will define the conditions for actual device operation.

Recommended Operating Conditions

Symbol	Parameter	Min	Nom	Max	Units
V_{CC}	Supply Voltage	4.75	5	5.25	V
V_{IH}	HIGH Level Input Voltage	2			V
V_{IL}	LOW Level Input Voltage			0.8	V
I_{OH}	HIGH Level Output Current			-0.8	mA
I_{OL}	LOW Level Output Current			16	mA
T_A	Free Air Operating Temperature	0		70	°C

Electrical Characteristics

over recommended operating free air temperature range (unless otherwise noted)

Symbol	Parameter	Conditions	Min	Typ (Note 2)	Max	Units
V_I	Input Clamp Voltage	$V_{CC} = \text{Min}, I_I = -12 \text{ mA}$			-1.5	V
V_{OH}	HIGH Level Output Voltage	$V_{CC} = \text{Min}, I_{OH} = \text{Max}$ $V_{IL} = \text{Max}, V_{IH} = \text{Min}$	2.4	3.4		V
V_{OL}	LOW Level Output Voltage	$V_{CC} = \text{Min}, I_{OL} = \text{Max}$ $V_{IH} = \text{Min}, V_{IL} = \text{Max}$		0.2	0.4	V
I_I	Input Current @ Max Input Voltage	$V_{CC} = \text{Max}, V_I = 5.5 \text{ V}$			1	mA
I_{IH}	HIGH Level Input Current	$V_{CC} = \text{Max}, V_I = 2.4 \text{ V}$			40	μA
I_{IL}	LOW Level Input Current	$V_{CC} = \text{Max}, V_I = 0.4 \text{ V}$			-1.6	mA
I_{OS}	Short Circuit Output Current	$V_{CC} = \text{Max}$ (Note 3)	-18		-55	mA
I_{CCH}	Supply Current with Outputs HIGH	$V_{CC} = \text{Max}$ (Note 4)		30	50	mA
I_{CCL}	Supply Current with Outputs LOW	$V_{CC} = \text{Max}$ (Note 3)(Note 5)		36	57	mA

Note 2: All typicals are at $V_{CC} = 5 \text{ V}, T_A = 25^\circ \text{C}$.

Note 3: Not more than one output should be shorted at a time.

Note 4: I_{CCH} is measured with all outputs open, one input of each gate at 4.5V, and the other inputs grounded.

Note 5: I_{CCL} is measured with all outputs open, and all inputs at ground.

Switching Characteristics

at $V_{CC} = 5 \text{ V}$ and $T_A = 25^\circ \text{C}$

Symbol	Parameter	Conditions	$C_L = 15 \text{ pF}, R_L = 400\Omega$		Units
			Min	Max	
t_{PLH}	Propagation Delay Time LOW-to-HIGH Level Output	Other Input LOW		23	ns
t_{PHL}	Propagation Delay Time HIGH-to-LOW Level Output			17	ns
t_{PLH}	Propagation Delay Time LOW-to-HIGH Level Output	Other Input HIGH		30	ns
t_{PHL}	Propagation Delay Time HIGH-to-LOW Level Output			22	ns

Physical Dimensions inches (millimeters) unless otherwise noted

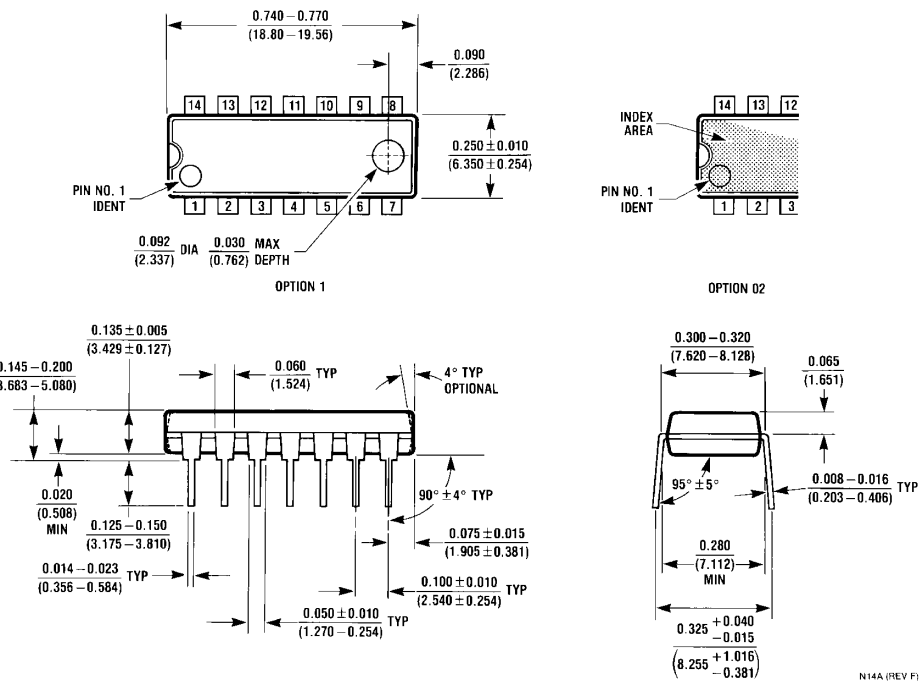

14-Lead Plastic Dual-In-Line Package (PDIP), JEDEC MS-001, 0.300" Wide Package Number N14A

N14A (REV F)

Fairchild does not assume any responsibility for use of any circuitry described, no circuit patent licenses are implied and Fairchild reserves the right at any time without notice to change said circuitry and specifications.

LIFE SUPPORT POLICY



FAIRCHILD'S PRODUCTS ARE NOT AUTHORIZED FOR USE AS CRITICAL COMPONENTS IN LIFE SUPPORT DEVICES OR SYSTEMS WITHOUT THE EXPRESS WRITTEN APPROVAL OF THE PRESIDENT OF FAIRCHILD SEMICONDUCTOR CORPORATION. As used herein:

1. Life support devices or systems are devices or systems which, (a) are intended for surgical implant into the body, or (b) support or sustain life, and (c) whose failure to perform when properly used in accordance with instructions for use provided in the labeling, can be reasonably expected to result in a significant injury to the user.
2. A critical component in any component of a life support device or system whose failure to perform can be reasonably expected to cause the failure of the life support device or system, or to affect its safety or effectiveness.

www.fairchildsemi.com

Looking for pricing, stock, or lifecycle information?

Click below to explore more details on WIN SOURCE:

-  [View 7486N on WIN SOURCE](#)
-  [Fairchild/ON Semiconductor](#) Information

Optimize Your Supply Chain with WIN SOURCE Solutions

-  Global Sourcing Solution
-  Obsolete Management
-  Cost Control Management
-  Shortage Management
-  Alternative Solution
-  Excess Inventory Management