



**THE DATASHEET OF  
74ABT16652CSSC**



# 74ABT16652

## 16-Bit Transceivers and Registers with 3-STATE Outputs

### General Description

The ABT16652 consists of sixteen bus transceiver circuits with D-type flip-flops, and control circuitry arranged for multiplexed transmission of data directly from the input bus or from the internal registers. Each byte has separate control inputs which can be shorted together for full 16-bit operation. Data on the A or B bus will be clocked into the registers as the appropriate clock pin goes to HIGH logic level. Output Enable pins (OEAB,  $\overline{\text{OEBA}}$ ) are provided to control the transceiver function.

### Features

- Independent registers for A and B buses
- Multiplexed real-time and stored data
- Separate control logic for each byte
- A and B output sink capability of 64 mA, source capability of 32 mA
- Guaranteed output skew
- High impedance glitch free bus loading during entire power up and power down cycle
- Nondestructive hot insertion capability

### Ordering Code:

Order Number	Package Number	Package Description
74ABT16652CSSC	MS56A	56-Lead Shrink Small Outline Package (SSOP), JEDEC MO-118, 0.300" Wide
74ABT16652CMTD	MTD56	56-Lead Thin Shrink Small Outline Package (TSSOP), JEDEC MO-153, 6.1mm Wide

Devices also available in Tape and Reel. Specify by appending the suffix letter "X" to the ordering code.

### Pin Descriptions

Pin Names	Descriptions
A <sub>0</sub> -A <sub>16</sub>	Data Register A Inputs/ 3-STATE Outputs
B <sub>0</sub> -B <sub>16</sub>	Data Register B Inputs/ 3-STATE Outputs
CPAB <sub>n</sub> , CPBA <sub>n</sub>	Clock Pulse Inputs
SAB <sub>n</sub> , SBA <sub>n</sub>	Select Inputs
OEAB <sub>n</sub> , $\overline{\text{OEBA}}$ <sub>n</sub>	Output Enable Inputs

### Connection Diagram

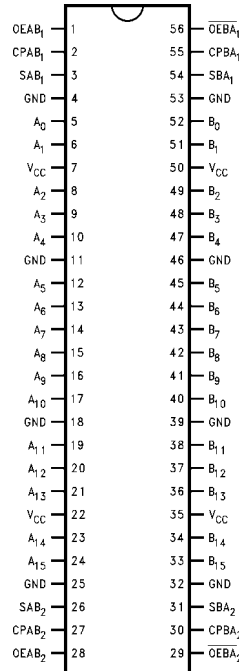

### Functional Description

In the transceiver mode, data present at the HIGH impedance port may be stored in either the A or B register or both.

The select (SAB<sub>n</sub>, SBA<sub>n</sub>) controls can multiplex stored and real-time.

The examples in *Figure 1* demonstrate the four fundamental bus-management functions that can be performed with the ABT16652.

Data on the A or B data bus, or both can be stored in the internal D flip-flop by LOW to HIGH transitions at the appropriate Clock Inputs (CPAB<sub>n</sub>, CPBA<sub>n</sub>) regardless of the Select or Output Enable Inputs. When SAB and SBA are in the real time transfer mode, it is also possible to store data without using the internal D flip-flops by simultaneously enabling OEAB<sub>n</sub> and  $\overline{OEBA}_n$ . In this configuration each Output reinforces its Input. Thus when all other data sources to the two sets of bus lines are in a HIGH impedance state, each set of bus lines will remain at its last state.

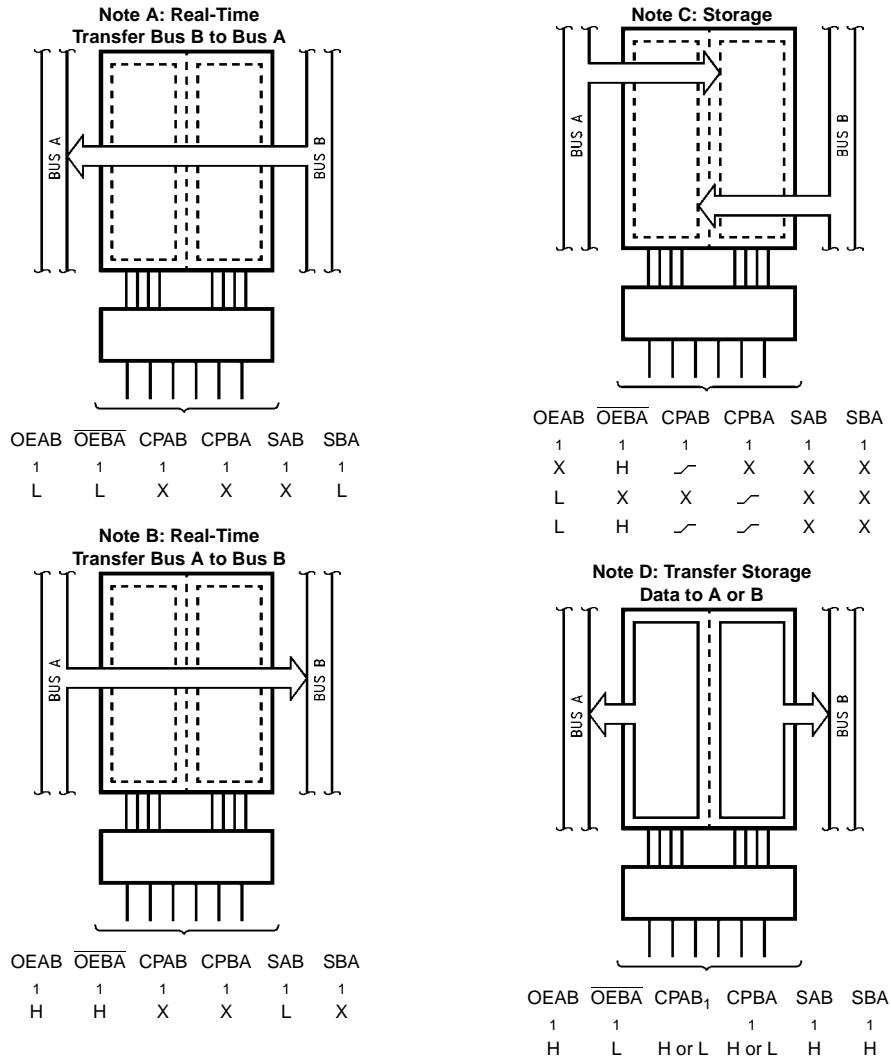

FIGURE 1.

### Function Table

Inputs						Inputs/Outputs (Note 1)		Operating Mode
OEAB <sub>1</sub>	$\overline{\text{OEBA}}_1$	CPAB <sub>1</sub>	CPBA <sub>1</sub>	SAB <sub>1</sub>	SBA <sub>1</sub>	A <sub>0</sub> thru A <sub>7</sub>	B <sub>0</sub> thru B <sub>7</sub>	
L	H	H or L	H or L	X	X	Input	Input	Isolation
L	H	↗	↗	X	X			Store A and B Data
X	H	↗	H or L	X	X	Input	Not Specified	Store A, Hold B
H	H	↗	↗	X	X	Input	Output	Store A in Both Registers
L	X	H or L	↗	X	X	Not Specified	Input	Hold A, Store B
L	L	↗	↗	X	X	Output	Input	Store B in Both Registers
L	L	X	X	X	L	Output	Input	Real-Time B Data to A Bus
L	L	X	H or L	X	H			Store B Data to A Bus
H	H	X	X	L	X	Input	Output	Real-Time A Data to B Bus
H	H	H or L	X	H	X			Stored A Data to B Bus
H	L	H or L	H or L	H	H	Output	Output	Stored A Data to B Bus and Stored B Data to A Bus

H = HIGH Voltage Level  
 L = LOW Voltage Level  
 X = Immaterial  
 ↗ = LOW to HIGH Clock Transition

**Note 1:** The data output functions may be enabled or disabled by various signals at OEAB or  $\overline{\text{OEBA}}$  inputs. Data input functions are always enabled, i.e., data at the bus pins will be stored on every LOW to HIGH transition on the clock inputs. This also applies to data I/O (A and B: 8–15) and #2 control pins.

### Logic Diagrams

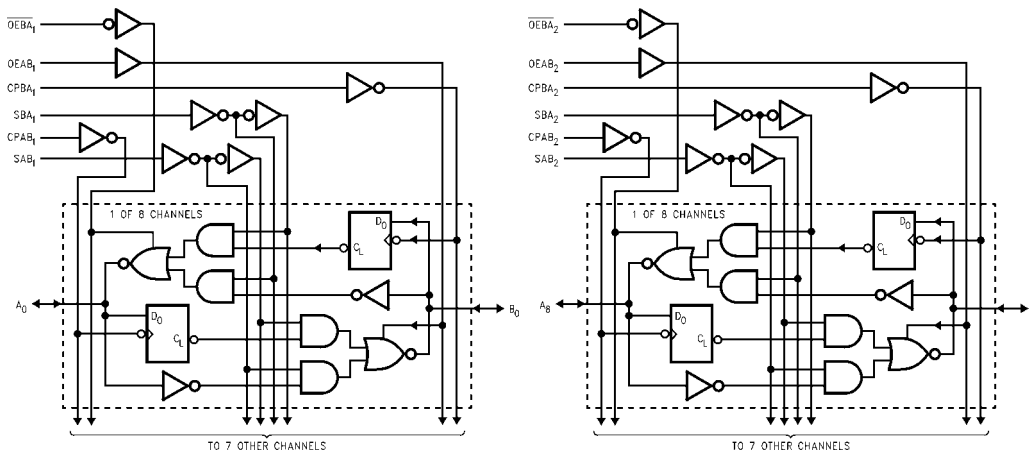

Please note that these diagrams are provided only for the understanding of logic operations and should not be used to estimate propagation delays.

**Absolute Maximum Ratings** (Note 2)

Storage Temperature	-65°C to +150°C
Ambient Temperature under Bias	-55°C to +125°C
Junction Temperature under Bias	-55°C to +150°C
V <sub>CC</sub> Pin Potential to Ground Pin	-0.5V to +7.0V
Input Voltage (Note 3)	-0.5V to +7.0V
Input Current (Note 3)	-30 mA to +5.0 mA
Voltage Applied to Any Output in the Disable or Power-Off State	-0.5V to +5.5V
in the HIGH State	-0.5V to V <sub>CC</sub>
Current Applied to Output in LOW State (Max)	twice the rated I <sub>OL</sub> (mA)
DC Latchup Source Current	-500 mA

Over Voltage Latchup (I/O)

10V

**Recommended Operating Conditions**

Free Air Ambient Temperature	-40°C to +85°C
Supply Voltage	+4.5V to +5.5V
Minimum Input Edge Rate ( $\Delta V/\Delta t$ )	
Data Input	50 mV/ns
Enable Input	20 mV/ns
Clock Input	100 mV/ns

**Note 2:** Absolute maximum ratings are values beyond which the device may be damaged or have its useful life impaired. Functional operation under these conditions is not implied.

**Note 3:** Either voltage limit or current limit is sufficient to protect inputs.

**DC Electrical Characteristics**

Symbol	Parameter	Min	Typ	Max	Units	V <sub>CC</sub>	Conditions
V <sub>IH</sub>	Input HIGH Voltage				V		Recognized HIGH Signal
V <sub>IL</sub>	Input LOW Voltage			0.8	V		Recognized LOW Signal
V <sub>CD</sub>	Input Clamp Diode Voltage			-1.2	V	Min	I <sub>IN</sub> = -18 mA (Non-I/O Pins)
V <sub>OH</sub>	Output HIGH Voltage	2.5 2.0			V	Min	I <sub>OH</sub> = -3 mA, (A <sub>n</sub> , B <sub>n</sub> ) I <sub>OH</sub> = -32 mA, (A <sub>n</sub> , B <sub>n</sub> )
V <sub>OL</sub>	Output LOW Voltage			0.55	V	Min	I <sub>OL</sub> = 64 mA, (A <sub>n</sub> , B <sub>n</sub> )
V <sub>ID</sub>	Input Leakage Test				V	0.0	I <sub>ID</sub> = 1.9 $\mu$ A, (Non-I/O Pins) All Other Pins Grounded
I <sub>IH</sub>	Input HIGH Current			1 1	$\mu$ A	Max	V <sub>IN</sub> = 2.7V (Non-I/O Pins) (Note 4) V <sub>IN</sub> = V <sub>CC</sub> (Non-I/O Pins)
I <sub>BVI</sub>	Input HIGH Current Breakdown Test			7	$\mu$ A	Max	V <sub>IN</sub> = 7.0V (Non-I/O Pins)
I <sub>BVIT</sub>	Input HIGH Current Breakdown Test (I/O)			100	$\mu$ A	Max	V <sub>IN</sub> = 5.5V (A <sub>n</sub> , B <sub>n</sub> )
I <sub>IL</sub>	Input LOW Current			-1 -1	$\mu$ A	Max	V <sub>IN</sub> = 0.5V (Non-I/O Pins) (Note 4) V <sub>IN</sub> = 0.0V (Non-I/O Pins)
I <sub>IH</sub> + I <sub>OZH</sub>	Output Leakage Current			10	$\mu$ A	0V-5.5V	V <sub>OUT</sub> = 2.7V (A <sub>n</sub> , B <sub>n</sub> ); OEAB <sub>n</sub> = GND and OEBA <sub>n</sub> = 2.0V
I <sub>IL</sub> + I <sub>OZL</sub>	Output Leakage Current			-10	$\mu$ A	0V-5.5V	V <sub>OUT</sub> = 0.5V (A <sub>n</sub> , B <sub>n</sub> ); OEAB <sub>n</sub> = GND and OEBA <sub>n</sub> = 2.0V
I <sub>OS</sub>	Output Short-Circuit Current			-275	mA	Max	V <sub>OUT</sub> = 0V (A <sub>n</sub> , B <sub>n</sub> )
I <sub>CEX</sub>	Output HIGH Leakage Current			50	$\mu$ A	Max	V <sub>OUT</sub> = V <sub>CC</sub> (A <sub>n</sub> , B <sub>n</sub> )
I <sub>ZZ</sub>	Bus Drainage Test			100	$\mu$ A	0.0V	V <sub>OUT</sub> = 5.5V (A <sub>n</sub> , B <sub>n</sub> ); All Others GND
I <sub>CCH</sub>	Power Supply Current			1.0	mA	Max	All Outputs HIGH
I <sub>CCL</sub>	Power Supply Current			60	mA	Max	All Outputs LOW
I <sub>CCZ</sub>	Power Supply Current			1.0	mA	Max	Outputs 3-STATE; All Others at V <sub>CC</sub> or GND
I <sub>CCT</sub>	Additional I <sub>CC</sub> /Input			2.5	mA	Max	V <sub>I</sub> = V <sub>CC</sub> - 2.1V All Others at V <sub>CC</sub> or GND
I <sub>CCD</sub>	Dynamic I <sub>CC</sub> (Note 4)	No Load		0.23	mA/MHz	Max	Outputs Open OEAB <sub>n</sub> , OEBA <sub>n</sub> and SEL = GND Non-I/O = GND or V <sub>CC</sub> One bit toggling, 50% duty cycle

**Note 4:** Guaranteed but not tested.

<b>DC Electrical Characteristics</b>							
(SSOP Package)							
Symbol	Parameter	Min	Typ	Max	Units	V <sub>CC</sub>	Conditions C <sub>L</sub> = 50 pF, R <sub>L</sub> = 500Ω
V <sub>OLP</sub>	Quiet Output Maximum Dynamic V <sub>OL</sub>		0.7	1.2	V	5.0	T <sub>A</sub> = 25°C (Note 5)
V <sub>OLV</sub>	Quiet Output Minimum Dynamic V <sub>OL</sub>	-1.4	-1.0		V	5.0	T <sub>A</sub> = 25°C (Note 5)
V <sub>OHV</sub>	Minimum HIGH Level Dynamic Output Voltage	2.5	3.0		V	5.0	T <sub>A</sub> = 25°C (Note 6)
V <sub>IHD</sub>	Minimum HIGH Level Dynamic Input Voltage	2.0	1.6		V	5.0	T <sub>A</sub> = 25°C (Note 7)
V <sub>ILD</sub>	Maximum LOW Level Dynamic Input Voltage		1.2	0.8	V	5.0	T <sub>A</sub> = 25°C (Note 7)
<p><b>Note 5:</b> Max number of outputs defined as (n). n – 1 data inputs are driven 0V to 3V. One output at LOW. Guaranteed, but not tested.</p> <p><b>Note 6:</b> Max number of outputs defined as (n). n – 1 data inputs are driven 0V to 3V. One output HIGH. Guaranteed, but not tested.</p> <p><b>Note 7:</b> Max number of data inputs (n) switching. n – 1 inputs switching 0V to 3V. Input-under-test switching: 3V to threshold (V<sub>ILD</sub>), 0V to threshold (V<sub>IHD</sub>). Guaranteed, but not tested.</p>							
<b>AC Electrical Characteristics</b>							
(SSOP Package)							
Symbol	Parameter	T <sub>A</sub> = +25°C V <sub>CC</sub> = +5.0V C <sub>L</sub> = 50 pF			T <sub>A</sub> = -40°C to +85°C V <sub>CC</sub> = 4.5V–5.5V C <sub>L</sub> = 50 pF		Units
		Min	Typ	Max	Min	Max	
t <sub>PLH</sub>	Propagation Delay	1.5	3.0	4.9	1.5	4.9	ns
t <sub>PHL</sub>	Clock to Bus	1.5	3.4	4.9	1.5	4.9	
t <sub>PLH</sub>	Propagation Delay	1.5	2.6	4.5	1.5	4.5	ns
t <sub>PHL</sub>	Bus to Bus	1.5	3.0	4.5	1.5	4.5	
t <sub>PLH</sub>	Propagation Delay	1.5	2.9	5.0	1.5	5.0	ns
t <sub>PHL</sub>	SBA <sub>n</sub> or SAB <sub>n</sub> to A <sub>n</sub> to B <sub>n</sub>	1.5	3.2	5.0	1.5	5.0	
t <sub>PZH</sub>	Enable Time	1.5	2.8	5.5	1.5	5.5	ns
t <sub>PZL</sub>	$\overline{\text{OEBA}}_n$ or OEAB <sub>n</sub> to A <sub>n</sub> or B <sub>n</sub>	1.5	3.0	5.5	1.5	5.5	
t <sub>PHZ</sub>	Disable Time	1.5	3.9	5.9	1.5	5.9	ns
t <sub>PLZ</sub>	$\overline{\text{OEBA}}_n$ or OEAB <sub>n</sub> to A <sub>n</sub> or B <sub>n</sub>	1.5	3.3	5.9	1.5	5.9	
<b>AC Operating Requirements</b>							
Symbol	Parameter	T <sub>A</sub> = +25°C V <sub>CC</sub> = +5.0V C <sub>L</sub> = 50 pF			T <sub>A</sub> = -40°C to +85°C V <sub>CC</sub> = 4.5V–5.5V C <sub>L</sub> = 50 pF		Units
		Min	Typ	Max	Min	Max	
f <sub>max</sub>	Max Clock Frequency		200				MHz
t <sub>S(H)</sub>	Setup Time, HIGH	2.0			2.0		ns
t <sub>S(L)</sub>	or LOW Bus to Clock						
t <sub>H(H)</sub>	Hold Time, HIGH	1.0			1.0		ns
t <sub>H(L)</sub>	or LOW Bus to Clock						
t <sub>W(H)</sub>	Pulse Width,	3.0			3.0		ns
t <sub>W(L)</sub>	HIGH or LOW						

Extended AC Electrical Characteristics								
(SSOP Package)								
Symbol	Parameter	$T_A = -40^\circ\text{C to } +85^\circ\text{C}$ $V_{CC} = 4.5\text{V} - 5.5\text{V}$ $C_L = 50\text{ pF}$ 16 Outputs Switching (Note 8)		$T_A = -40^\circ\text{C to } +85^\circ\text{C}$ $V_{CC} = 4.5\text{V} - 5.5\text{V}$ $C_L = 250\text{ pF}$ 1 Output Switching (Note 9)		$T_A = -40^\circ\text{C to } +85^\circ\text{C}$ $V_{CC} = 4.5\text{V} - 5.5\text{V}$ $C_L = 250\text{ pF}$ 16 Outputs Switching (Note 10)		Units
		Min	Max	Min	Max	Min	Max	
$t_{PLH}$	Propagation Delay	1.5	5.8	2.0	7.5	2.5	10.0	ns
$t_{PHL}$	Clock to Bus	1.5	5.8	2.0	7.5	2.5	10.0	ns
$t_{PLH}$	Propagation Delay	1.5	6.5	2.0	7.0	2.5	9.5	ns
$t_{PHL}$	Bus to Bus	1.5	6.5	2.0	7.0	2.5	9.5	ns
$t_{PLH}$	Propagation Delay	1.5	6.0	2.0	7.5	2.5	10.0	ns
$t_{PHL}$	SBA or SAB to $A_n$ or $B_n$	1.5	6.0	2.0	7.5	2.5	10.0	ns
$t_{PZH}$	Output Enable Time	1.5	6.0	2.0	8.0	2.5	10.5	ns
$t_{PZL}$	$\overline{OEBA}_n$ or $OEAB_n$ to $A_n$ or $B_n$	1.5	6.0	2.0	8.0	2.5	10.5	ns
$t_{PHZ}$	Output Disable Time	1.5	6.0	(Note 11)		(Note 11)		ns
$t_{PLZ}$	$\overline{OEBA}$ or $OEAB$ to $A_n$ or $B_n$	1.5	6.0	(Note 11)		(Note 11)		ns
<p><b>Note 8:</b> This specification is guaranteed but not tested. The limits apply to propagation delays for all paths described switching in phase (i.e., all LOW-to-HIGH, HIGH-to-LOW, etc.).</p> <p><b>Note 9:</b> This specification is guaranteed but not tested. The limits represent propagation delay with 250 pF load capacitors in place of the 50 pF load capacitors in the standard AC load. This specification pertains to single output switching only.</p> <p><b>Note 10:</b> This specification is guaranteed but not tested. The limits represent propagation delays for all paths described switching in phase (i.e., all LOW-to-HIGH, HIGH-to-LOW, etc.) with 250 pF load capacitors in place of the 50 pF load capacitors in the standard AC load.</p> <p><b>Note 11:</b> The 3-STATE delay times are dominated by the RC network (500<math>\Omega</math>, 250 pF) on the output and has been excluded from the datasheet.</p>								
Skew (Note 12)								
(SSOP Package)								
Symbol	Parameter	$T_A = -40^\circ\text{C to } +85^\circ\text{C}$ $V_{CC} = 4.5\text{V} - 5.5\text{V}$ $C_L = 50\text{ pF}$ 16 Outputs Switching (Note 12)		$T_A = -40^\circ\text{C to } +85^\circ\text{C}$ $V_{CC} = 4.5\text{V} - 5.5\text{V}$ $C_L = 250\text{ pF}$ 16 Outputs Switching (Note 13)				Units
		Max		Max				
$t_{OSHL}$ (Note 14)	Pin to Pin Skew HL Transitions	2.0		2.5				ns
$t_{OSLH}$ (Note 14)	Pin to Pin Skew LH Transitions	2.0		2.5				ns
$t_{PS}$ (Note 15)	Duty Cycle LH-HL Skew	2.0		2.5				ns
$t_{OST}$ (Note 14)	Pin to Pin Skew LH/HL Transitions	2.8		3.0				ns
$t_{PV}$ (Note 16)	Device to Device Skew LH/HL Transitions	3.5		4.0				ns
<p><b>Note 12:</b> This specification is guaranteed but not tested. The limits apply to propagation delays for all paths described switching in phase (i.e., all LOW-to-HIGH, HIGH-to-LOW, etc.).</p> <p><b>Note 13:</b> This specification is guaranteed but not tested. The limits represent propagation delays with 250 pF load capacitors in place of the 50 pF load capacitors in the standard AC load.</p> <p><b>Note 14:</b> Skew is defined as the absolute value of the difference between the actual propagation delays for any two separate outputs of the same device. The specification applies to any outputs switching HIGH to LOW (<math>t_{OSHL}</math>), LOW to HIGH (<math>t_{OSLH}</math>), or any combination switching LOW to HIGH and/or HIGH to LOW (<math>t_{OST}</math>). This specification is guaranteed but not tested.</p> <p><b>Note 15:</b> This describes the difference between the delay of the LOW-to-HIGH and the HIGH-to-LOW transition on the same pin. It is measured across all the outputs (drivers) on the same chip, the worst (largest delta) number is the guaranteed specification. This specification is guaranteed but not tested.</p> <p><b>Note 16:</b> Propagation delay variation for a given set of conditions (i.e., temperature and <math>V_{CC}</math>) from device to device. This specification is guaranteed but not tested.</p>								

## Capacitance

Symbol	Parameter	Typ	Units	Conditions ( $T_A = 25^\circ\text{C}$ )
$C_{IN}$	Input Capacitance	5.0	pF	$V_{CC} = 0\text{V}$ (non I/O pins)
$C_{I/O}$ (Note 17)	I/O Capacitance	11.0	pF	$V_{CC} = 5.0\text{V}$ ( $A_n, B_n$ )

Note 17:  $C_{I/O}$  is measured at frequency,  $f = 1\text{ MHz}$ , per MIL-STD-883, Method 3012.

## AC Loading

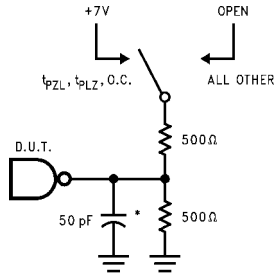

\*Includes jig and probe capacitance

FIGURE 2. Standard AC Test Load

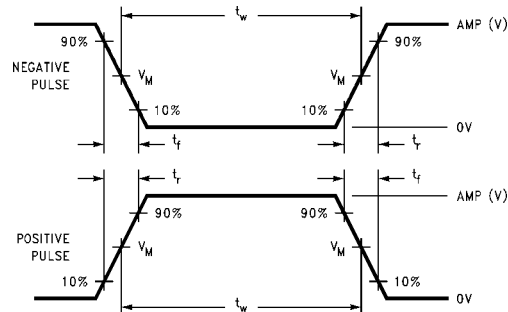

FIGURE 3. Test Input Signal Levels

### Input Pulse Requirement

Amplitude	Rep. Rate	$t_w$	$t_r$	$t_f$
3.0V	1 MHz	500 ns	2.5 ns	2.5 ns

FIGURE 4. Test input Signal Requirements

## AC Waveforms

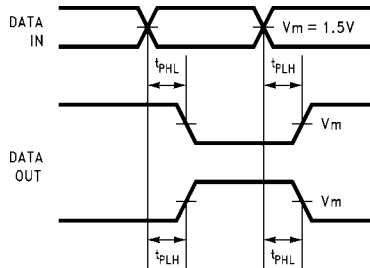

FIGURE 5. Propagation Delay Waveforms for Inverting and Non-Inverting Functions

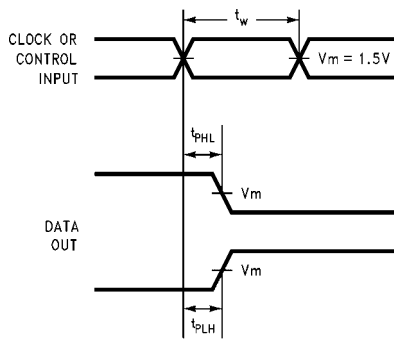

FIGURE 6. Propagation Delay, Pulse Width Waveforms

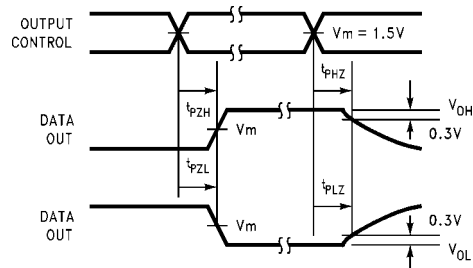

FIGURE 7. 3-STATE Output HIGH and LOW Enable and Disable Times

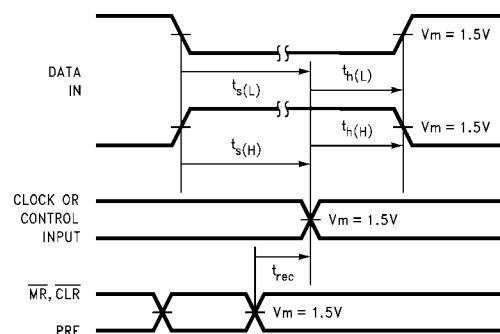
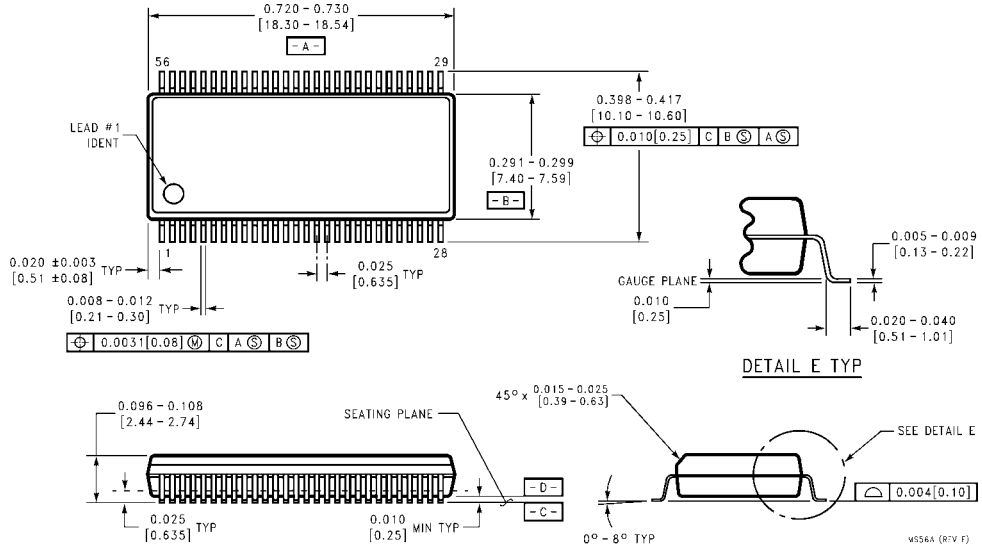

FIGURE 8. Setup Time, Hold Time and Recovery Time Waveforms

**Physical Dimensions** inches (millimeters) unless otherwise noted



**56-Lead Shrink Small Outline Package (SSOP), JEDEC MO-118, 0.300" Wide  
Package Number MS56A**

**Physical Dimensions** inches (millimeters) unless otherwise noted (Continued)

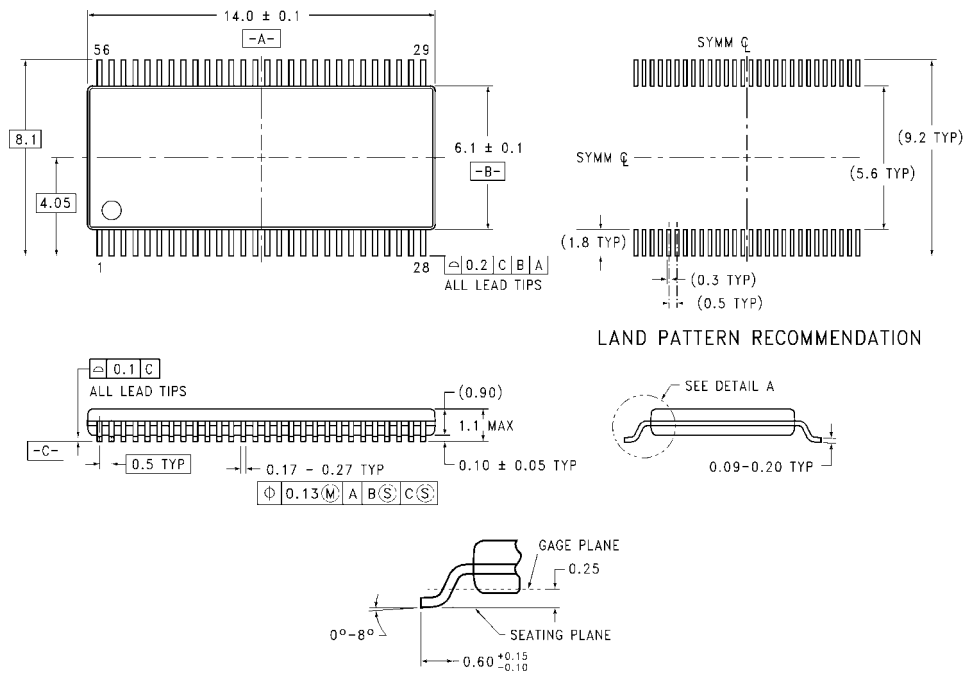

**56-Lead Thin Shrink Small Outline Package (TSSOP), JEDEC MO-153, 6.1mm Wide Package Number MTD56**

MTD56 (REV B)

**LIFE SUPPORT POLICY**

FAIRCHILD'S PRODUCTS ARE NOT AUTHORIZED FOR USE AS CRITICAL COMPONENTS IN LIFE SUPPORT DEVICES OR SYSTEMS WITHOUT THE EXPRESS WRITTEN APPROVAL OF THE PRESIDENT OF FAIRCHILD SEMICONDUCTOR CORPORATION. As used herein:



1. Life support devices or systems are devices or systems which, (a) are intended for surgical implant into the body, or (b) support or sustain life, and (c) whose failure to perform when properly used in accordance with instructions for use provided in the labeling, can be reasonably expected to result in a significant injury to the user.
2. A critical component in any component of a life support device or system whose failure to perform can be reasonably expected to cause the failure of the life support device or system, or to affect its safety or effectiveness.

[www.fairchildsemi.com](http://www.fairchildsemi.com)

Fairchild does not assume any responsibility for use of any circuitry described, no circuit patent licenses are implied and Fairchild reserves the right at any time without notice to change said circuitry and specifications.

## Looking for pricing, stock, or lifecycle information?

Click below to explore more details on WIN SOURCE:

-  [View 74ABT16652CSSC on WIN SOURCE](#)
-  [Fairchild/ON Semiconductor Information](#)

## Optimize Your Supply Chain with WIN SOURCE Solutions

-  Global Sourcing Solution
-  Obsolete Management
-  Cost Control Management
-  Shortage Management
-  Alternative Solution
-  Excess Inventory Management