



THE DATASHEET OF SC4524BSETRT



POWER MANAGEMENT

Features

- Wide input range: 3V to 18V
- 2A Output Current
- 200kHz to 2MHz Programmable Frequency
- Precision 1V Feedback Voltage
- Peak Current-Mode Control
- Cycle-by-Cycle Current Limiting
- Hiccup Overload Protection with Frequency Foldback
- Soft-Start and Enable
- Thermal Shutdown
- Thermally Enhanced 8-pin SOIC Package
- Fully RoHS and WEEE compliant

Applications

- XDSL and Cable Modems
- Set Top Boxes
- Point of Load Applications
- CPE Equipment
- DSP Power Supplies
- LCD and Plasma TVs

Description

The SC4524B is a constant frequency peak current-mode step-down switching regulator capable of producing 2A output current from an input ranging from 3V to 18V. The switching frequency of the SC4524B is programmable up to 2MHz, allowing the use of small inductors and ceramic capacitors for miniaturization, and high input/output conversion ratio. The SC4524B is suitable for next generation XDSL modems, high-definition TVs and various point of load applications.

Peak current-mode PWM control employed in the SC4524B achieves fast transient response with simple loop compensation. Cycle-by-cycle current limiting and hiccup overload protection reduces power dissipation during output overload. Soft-start function reduces input start-up current and prevents the output from overshooting during power-up.

The SC4524B is available in SOIC-8 EDP package.

Typical Application Circuit

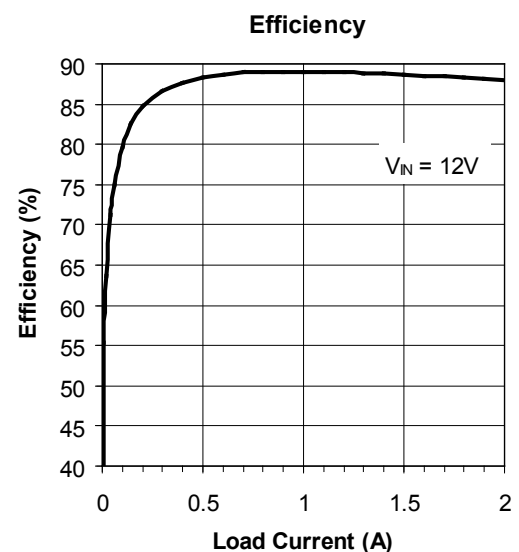
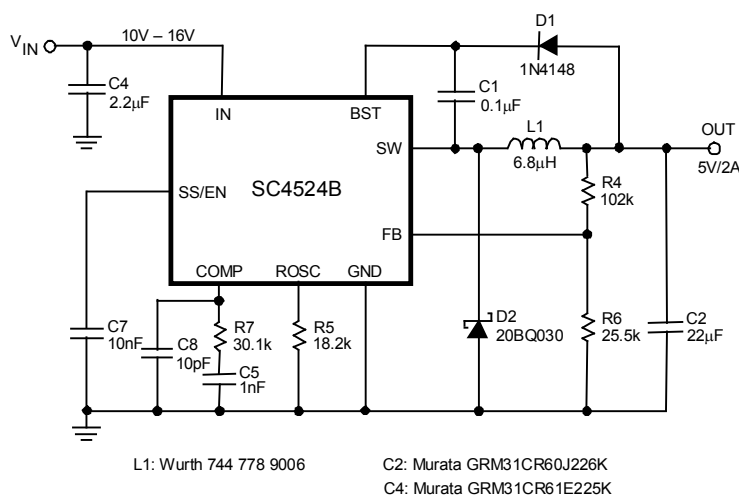
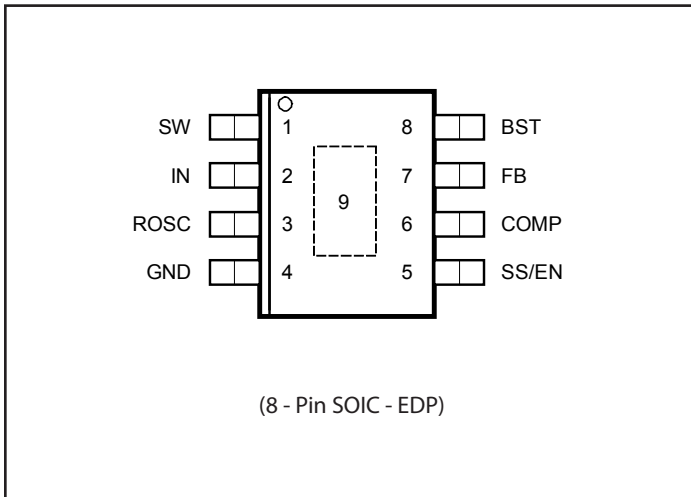

Figure 1. 1MHz 10V-16V to 5V/2A Step-down Converter

Pin Configuration



Ordering Information

Device	Package
SC4524BSETRT ⁽¹⁾⁽²⁾	SOIC-8 EDP
SC4524BEVB	Evaluation Board

Notes:

- (1) Available in tape and reel only. A reel contains 2,500 devices.
- (2) Available in lead-free package only. Device is fully WEEE and RoHS compliant.

Marking Information

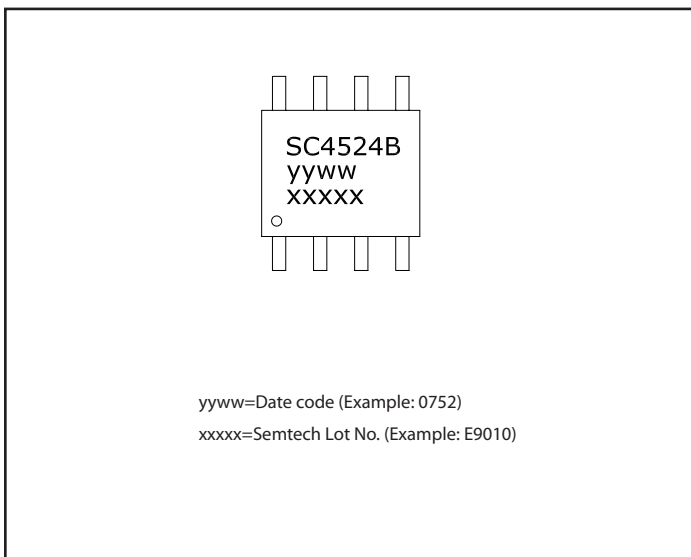

Absolute Maximum Ratings

V_{IN} Supply Voltage	-0.3 to 24V
BST Voltage	40V
BST Voltage above SW	24V
SS Voltage	-0.3 to 3V
FB Voltage	-0.3 to V_{IN}
SW Voltage	-0.6 to V_{IN}
SW Transient Spikes (10ns Duration).....	-2.5V to $V_{IN} + 1.5V$
Peak IR Reflow Temperature	260°C
ESD Protection Level ⁽²⁾	2000V

Thermal Information

Junction to Ambient ⁽¹⁾	36°C/W
Junction to Case ⁽¹⁾	5.5°C/W
Maximum Junction Temperature.....	150°C
Storage Temperature	-65 to +150°C
Lead Temperature (Soldering) 10 sec	300°C

Recommended Operating Conditions

Input Voltage Range	3V to 18V
Maximum Output Current	2A

Exceeding the above specifications may result in permanent damage to the device or device malfunction. Operation outside of the parameters specified in the Electrical Characteristics section is not recommended.

NOTES-

- (1) Calculated from package in still air, mounted to 3" x 4.5", 4 layer FR4 PCB with thermal vias under the exposed pad per JESD51 standards.
- (2) Tested according to JEDEC standard JESD22-A114-B.

Electrical Characteristics

Unless otherwise noted, $V_{IN} = 12V$, $V_{BST} = 15V$, $V_{SS} = 2.2V$, $-40^{\circ}C < T_A = T_J < 125^{\circ}C$, $R_{OSC} = 12.1k\Omega$.

Parameter	Conditions	Min	Typ	Max	Units
Input Supply					
Input Voltage Range		3		18	V
V_{IN} Start Voltage	V_{IN} Rising	2.70	2.82	2.95	V
V_{IN} Start Hysteresis			225		mV
V_{IN} Quiescent Current	$V_{COMP} = 0$ (Not Switching)		2	2.6	mA
V_{IN} Quiescent Current in Shutdown	$V_{SS/EN} = 0$, $V_{IN} = 12V$		40	50	μA
Error Amplifier					
Feedback Voltage		0.980	1.000	1.020	V
Feedback Voltage Line Regulation	$V_{IN} = 3V$ to 18V		0.005		%/V
FB Pin Input Bias Current	$V_{FB} = 1V$, $V_{COMP} = 0.8V$		-170	-340	nA
Error Amplifier Transconductance			280		$\mu\Omega^{-1}$
Error Amplifier Open-loop Gain			60		dB
COMP Pin to Switch Current Gain			8		A/V
COMP Maximum Voltage	$V_{FB} = 0.9V$		2.4		V
COMP Source Current	$V_{FB} = 0.8V$, $V_{COMP} = 0.8V$		17		μA
COMP Sink Current	$V_{FB} = 1.2V$, $V_{COMP} = 0.8V$		25		
Internal Power Switch					
Switch Current Limit	(Note 1)	2.6	3.3	4.3	A
Switch Saturation Voltage	$I_{SW} = -2.6A$		250	400	mV

Electrical Characteristics (Cont.)

Unless otherwise noted, $V_{IN} = 12V$, $V_{BST} = 15V$, $V_{SS} = 2.2V$, $-40^{\circ}C < T_A = T_J < 125^{\circ}C$, $R_{OSC} = 12.1k\Omega$.

Parameter	Conditions	Min	Typ	Max	Units
Minimum Switch On-time			135		ns
Minimum Switch Off-time			100	150	ns
Switch Leakage Current				10	μA
Minimum Bootstrap Voltage	$I_{SW} = -2.6A$		1.8	2.3	V
BST Pin Current	$I_{SW} = -2.6A$		60	95	mA
Oscillator					
Switching Frequency	$R_{OSC} = 12.1k\Omega$	1.04	1.3	1.56	MHz
	$R_{OSC} = 93.1k\Omega$	240	300	360	kHz
Foldback Frequency	$R_{OSC} = 12.1k\Omega, V_{FB} = 0$	110	230	350	kHz
	$R_{OSC} = 93.1k\Omega, V_{FB} = 0$	50	100	170	
Soft Start and Overload Protection					
SS/EN Shutdown Threshold		0.2	0.3	0.4	V
SS/EN Switching Threshold	$V_{FB} = 0V$	1.0	1.13	1.3	V
Soft-start Charging Current	$V_{SS/EN} = 0V$		1.7		μA
	$V_{SS/EN} = 1.5V$	1.2	2.0	2.8	
Soft-start Discharging Current			1.5		μA
Hiccup Arming SS/EN Voltage	$V_{SS/EN}$ Rising		2.15		V
Hiccup SS/EN Overload Threshold	$V_{SS/EN}$ Falling		1.9		V
Hiccup Retry SS/EN Voltage	$V_{SS/EN}$ Falling	0.6	1.0	1.2	V
Over Temperature Protection					
Thermal Shutdown Temperature			165		$^{\circ}C$
Thermal Shutdown Hysteresis			10		$^{\circ}C$

Note 1: Switch current limit does not vary with duty cycle.

Pin Descriptions

SO-8	Pin Name	Pin Function
1	SW	Emitter of the internal NPN power transistor. Connect this pin to the inductor, the freewheeling diode and the bootstrap capacitor.
2	IN	Power supply to the regulator. It is also the collector of the internal NPN power transistor. It must be closely bypassed to the ground plane.
3	ROSC	An external resistor from this pin to ground sets the oscillator frequency.
4	GND	Ground pin
5	SS/EN	Soft-start and regulator enable pin. A capacitor from this pin to ground provides soft-start and overload hiccup functions. Hiccup can be disabled by overcoming the internal soft-start discharging current with an external pull-up resistor connected between the SS/EN and the IN pins. Pulling the SS/EN pin below 0.2V completely shuts off the regulator to low current state.
6	COMP	The output of the internal error amplifier. The voltage at this pin controls the peak switch current. A RC compensation network at this pin stabilizes the regulator.
7	FB	The inverting input of the error amplifier. If V_{FB} falls below 0.8V, then the switching frequency will be reduced to improve short-circuit robustness (see Applications Information for details).
8	BST	Supply pin to the power transistor driver. Tie to an external diode-capacitor bootstrap circuit to generate drive voltage higher than V_{IN} in order to fully enhance the internal NPN power transistor.
9	Exposed Pad	The exposed pad serves as a thermal contact to the circuit board. It is to be soldered to the ground plane of the PC board.

Block Diagram

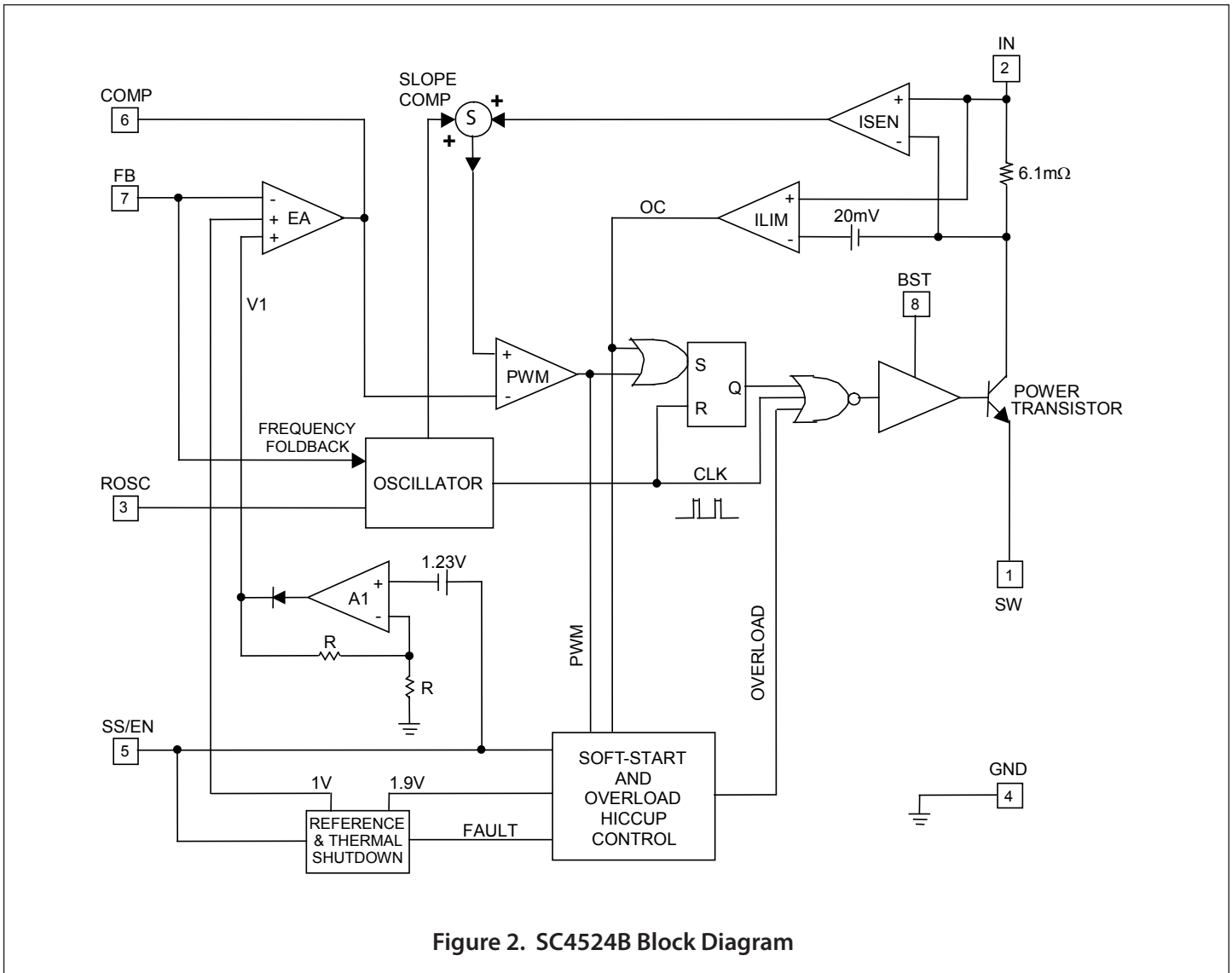

Figure 2. SC4524B Block Diagram

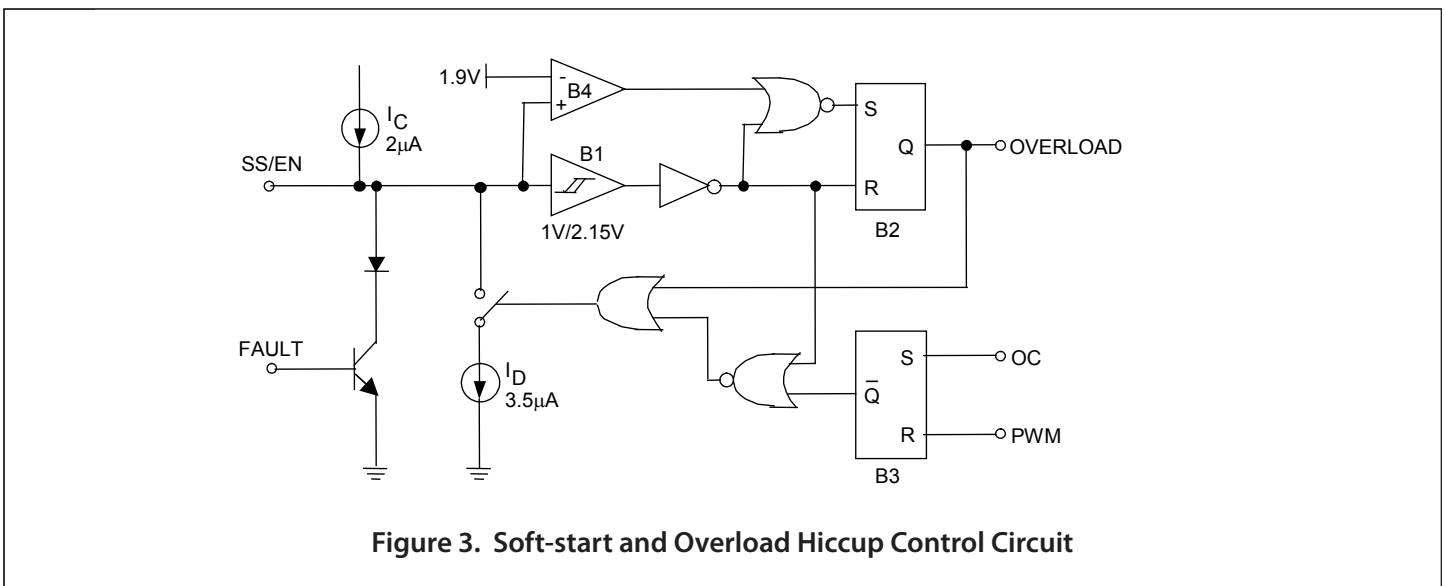
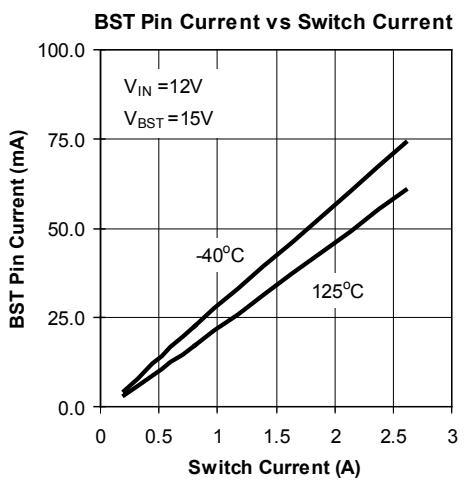
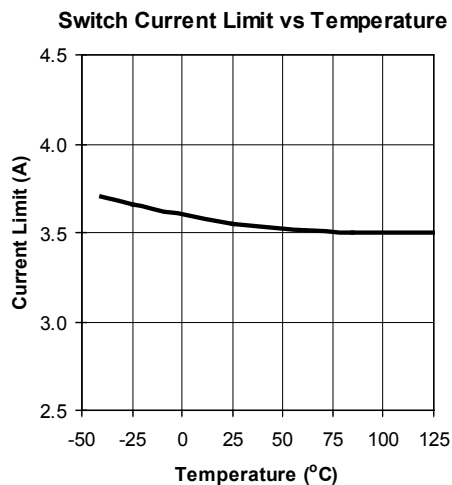
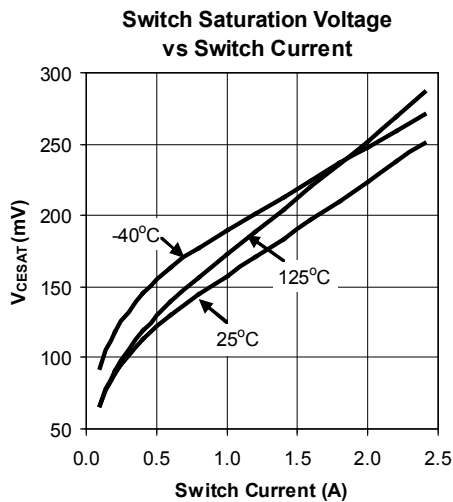
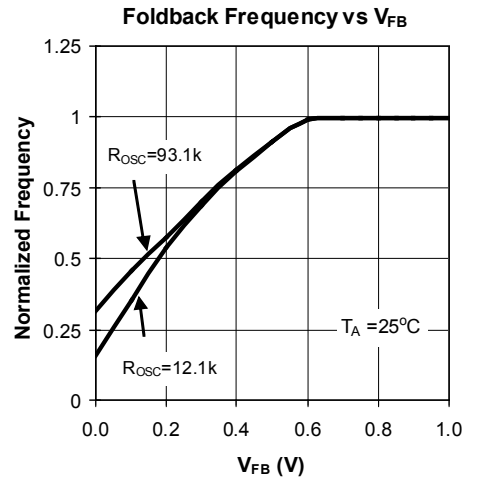
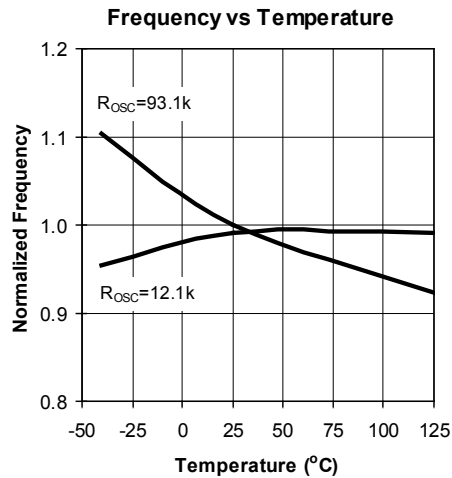
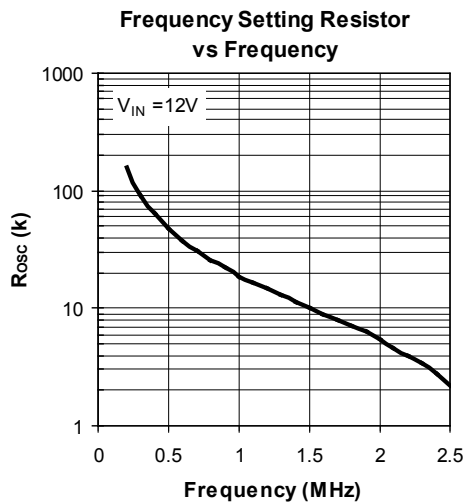
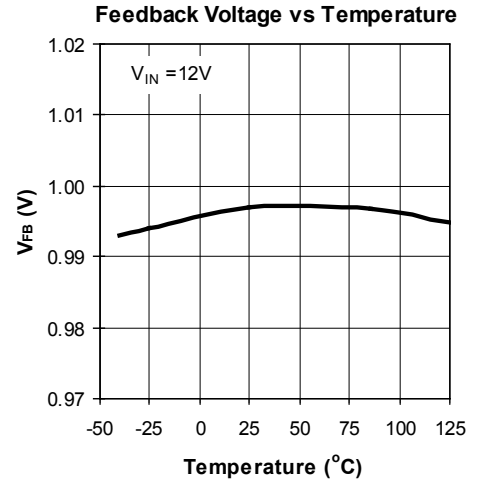
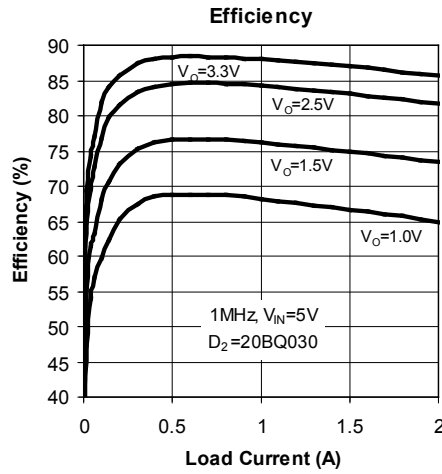
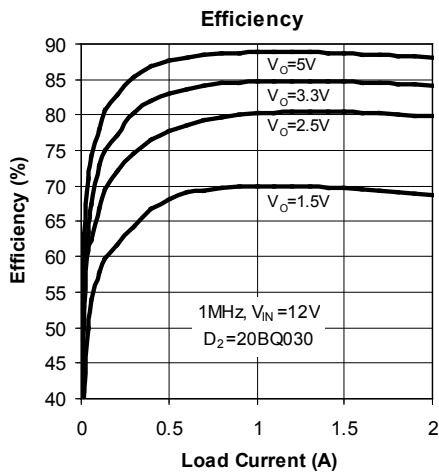
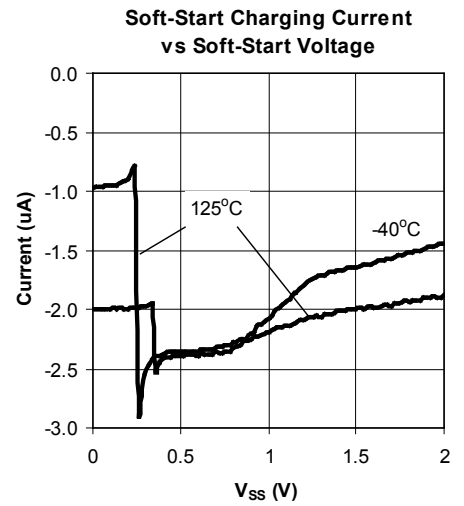
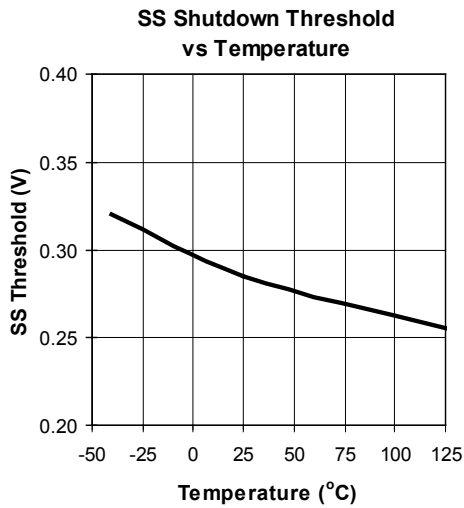
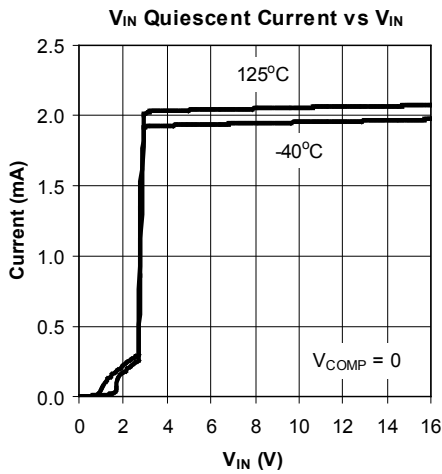
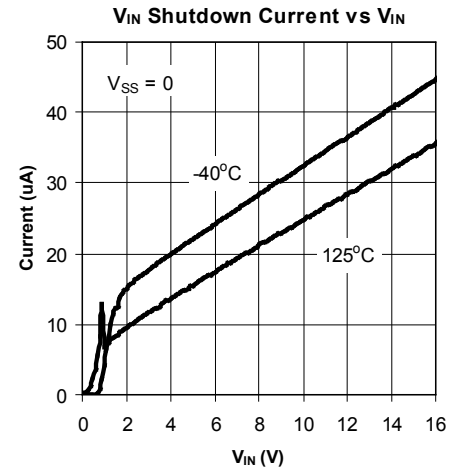
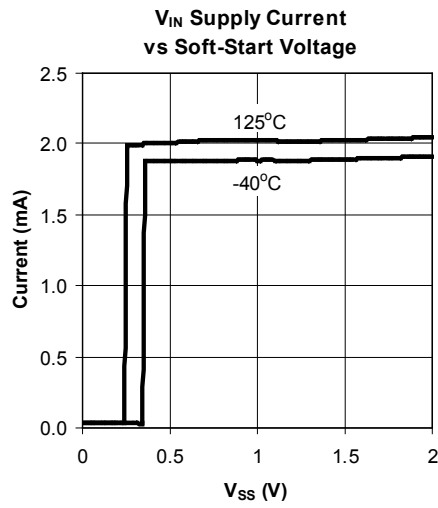
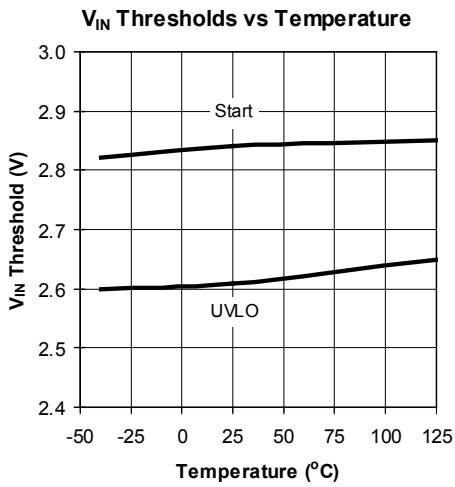

Figure 3. Soft-start and Overload Hiccup Control Circuit

Typical Characteristics



Typical Characteristics (Cont.)

Applications Information

Operation

The SC4524B is a constant-frequency, peak current-mode, step-down switching regulator with an integrated 18V, 2.6A power NPN transistor. Programmable switching frequency makes the regulator design more flexible. With the peak current-mode control, the double reactive poles of the output LC filter are reduced to a single real pole by the inner current loop. This simplifies loop compensation and achieves fast transient response with a simple Type-2 compensation network.

As shown in Figure 2, the switch collector current is sensed with an integrated 6.1mΩ sense resistor. The sensed current is summed with a slope-compensating ramp before it is compared with the transconductance error amplifier (EA) output. The PWM comparator trip point determines the switch turn-on pulse width. The current-limit comparator ILIM turns off the power switch when the sensed signal exceeds the 20mV current-limit threshold.

Driving the base of the power transistor above the input power supply rail minimizes the power transistor saturation voltage and maximizes efficiency. An external bootstrap circuit (formed by the capacitor C₁ and the diode D₁ in Figure 1) generates such a voltage at the BST pin for driving the power transistor.

Shutdown and Soft-Start

The SS/EN pin is a multiple-function pin. An external capacitor (4.7nF to 22nF) connected from the SS pin to ground sets the soft-start and overload shutoff times of the regulator (Figure 3). The effect of V_{SS/EN} on the SC4524B is summarized in Table 1.

Table 1: SS/EN operation modes

SS/EN	Mode	Supply Current
<0.2V	Shutdown	18μA @ 5Vin
0.4V to 1.23V	Not switching	2mA
1.23V to 2.1V	Switching & hiccup disabled	Load dependent
>2.1V	Switching & hiccup armed	

Pulling the SS/EN pin below 0.2V shuts off the regulator and reduces the input supply current to 18μA (V_{IN} = 5V).

When the SS/EN pin is released, the soft-start capacitor is charged with an internal 1.6μA current source (not shown in Figure 3). As the SS/EN voltage exceeds 0.4V, the internal bias circuit of the SC4524B turns on and the SC4524B draws 2mA from V_{IN}. The 1.6μA charging current turns off and the 2μA current source I_C in Figure 3 slowly charges the soft-start capacitor.

The error amplifier EA in Figure 2 has two non-inverting inputs. The non-inverting input with the lower voltage predominates. One of the non-inverting inputs is biased to a precision 1V reference and the other non-inverting input is tied to the output of the amplifier A₁. Amplifier A₁ produces an output V₁ = 2(V_{SS/EN} - 1.23V). V₁ is zero and COMP is forced low when V_{SS/EN} is below 1.23V. During start up, the effective non-inverting input of EA stays at zero until the soft-start capacitor is charged above 1.23V. Once V_{SS/EN} exceeds 1.23V, COMP is released. The regulator starts to switch when V_{COMP} rises above 0.4V. If the soft-start interval is made sufficiently long, then the FB voltage (hence the output voltage) will track V₁ during start up. V_{SS/EN} must be at least 1.83V for the output to achieve regulation. Proper soft-start prevents output overshoot. Current drawn from the input supply is also well controlled.

Overload / Short-Circuit Protection

Table 2 lists various fault conditions and their corresponding protection schemes in the SC4524B.

Table 2: Fault conditions and protections

Condition	Fault	Protective Action
IL > ILimit, VFB > 0.8V	Over current	Cycle-by-cycle limit at programmed frequency
IL > ILimit, VFB < 0.8V	Over current	Cycle-by-cycle limit with frequency foldback
VSS/EN Falling SS/EN < 1.9V	Persistent over current or short circuit	Shutdown, then retry (Hiccup)
Tj > 160C	Over temperature	Shutdown

As summarized in Table 1, overload shutdown is disabled during soft-start (V_{SS/EN} < 2.1V). In Figure 3, the reset input of the overload latch B₂ will remain high if the SS/EN voltage is below 2.1V. Once the soft-start capacitor is charged above 2.1V, the output of the Schmitt trigger B₁ goes high, the reset input of B₂ goes low and hiccup becomes armed.

Applications Information (Cont.)

As the load draws more current from the regulator, the current-limit comparator ILIM (Figure 2) will eventually limit the switch current on a cycle-by-cycle basis. The over-current signal OC goes high, setting the latch B₃. The soft-start capacitor is discharged with (I_D - I_C) (Figure 3). If the inductor current falls below the current limit and the PWM comparator instead turns off the switch, then latch B₃ will be reset and I_C will recharge the soft-start capacitor. If over-current condition persists or OC becomes asserted more often than PWM over a period of time, then the soft-start capacitor will be discharged below 1.9V. At this juncture, comparator B₄ sets the overload latch B₂. The soft-start capacitor will be continuously discharged with (I_D - I_C). The COMP pin is immediately pulled to ground. The switching regulator is shut off until the soft-start capacitor is discharged below 1.0V. At this moment, the overload latch is reset. The soft-start capacitor is recharged and the converter again undergoes soft-start. The regulator will go through soft-start, overload shutdown and restart until it is no longer overloaded.

If the FB voltage falls below 0.8V because of output overload, then the switching frequency will be reduced. Frequency foldback helps to limit the inductor current when the output is hard shorted to ground.

During normal operation, the soft-start capacitor is charged to 2.4V.

Setting the Output Voltage

The regulator output voltage is set with an external resistive divider (Figure 1) with its center tap tied to the FB pin. For a given R₆ value, R₄ can be found by

$$R_4 = R_6 \left(\frac{V_O}{1.0V} - 1 \right) \quad (1)$$

Setting the Switching Frequency

The switching frequency of the SC4524B is set with an external resistor from the ROSC pin to ground.

Minimum On Time Consideration

The operating duty cycle of a non-synchronous step-

down switching regulator in continuous-conduction mode (CCM) is given by

$$D = \frac{V_O + V_D}{V_{IN} + V_D - V_{CESAT}} \quad (2)$$

where V_{CESAT} is the switch saturation voltage and V_D is voltage drop across the rectifying diode.

In peak current-mode control, the PWM modulating ramp is the sensed current ramp of the power switch. This current ramp is absent unless the switch is turned on. The intersection of this ramp with the output of the voltage feedback error amplifier determines the switch pulse width. The propagation delay time required to immediately turn off the switch after it is turned on is the minimum controllable switch on time (T_{ON(MIN)}).

Closed-loop measurement shows that the SC4524B minimum on time is about 135ns at room temperature (Figure 4). If the required switch on time is shorter than the minimum on time, the regulator will either skip cycles or it will jitter.

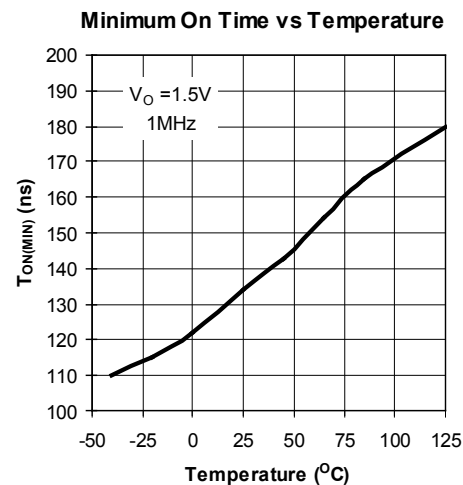

Figure 4. Variation of Minimum On Time with Ambient Temperature

To allow for transient headroom, the minimum operating switch on time should be at least 20% to 30% higher than the worst-case minimum on time.

Applications Information (Cont.)

Minimum Off Time Limitation

The PWM latch in Figure 2 is reset every cycle by the clock. The clock also turns off the power transistor to refresh the bootstrap capacitor. This minimum off time limits the attainable duty cycle of the regulator at a given switching frequency. The measured minimum off time is 100ns typically. If the required duty cycle is higher than the attainable maximum, then the output voltage will not be able to reach its set value in continuous-conduction mode.

Inductor Selection

The inductor ripple current for a non-synchronous step-down converter in continuous-conduction mode is

$$\Delta I_L = \frac{(V_O + V_D) \cdot (1 - D)}{F_{SW} \cdot L_1} \quad (3)$$

where F_{SW} is the switching frequency and L_1 is the inductance.

An inductor ripple current between 20% to 50% of the maximum load current gives a good compromise among efficiency, cost and size. Re-arranging Equation (3) and assuming 35% inductor ripple current, the inductor is given by

$$L_1 = \frac{(V_O + V_D) \cdot (1 - D)}{35\% \cdot I_O \cdot F_{SW}} \quad (4)$$

If the input voltage varies over a wide range, then choose L_1 based on the nominal input voltage. Always verify converter operation at the input voltage extremes.

The peak current limit of SC4524B power transistor is at least 2.6A. The maximum deliverable load current for the SC4524B is 2.6A minus one half of the inductor ripple current.

Input Decoupling Capacitor

The input capacitor should be chosen to handle the RMS ripple current of a buck converter. This value is given by

$$I_{RMS_CIN} = I_O \cdot \sqrt{D \cdot (1 - D)} \quad (5)$$

The input capacitance must also be high enough to keep input ripple voltage within specification. This is important in reducing the conductive EMI from the regulator. The input capacitance can be estimated from

$$C_{IN} > \frac{I_O}{4 \cdot \Delta V_{IN} \cdot F_{SW}} \quad (6)$$

where ΔV_{IN} is the allowable input ripple voltage.

Multi-layer ceramic capacitors, which have very low ESR (a few mΩ) and can easily handle high RMS ripple current, are the ideal choice for input filtering. A single 4.7μF X5R ceramic capacitor is adequate for 500kHz or higher switching frequency applications, and 10μF is adequate for 200kHz to 500kHz switching frequency. For high voltage applications, a small ceramic (1μF or 2.2μF) can be placed in parallel with a low ESR electrolytic capacitor to satisfy both the ESR and bulk capacitance requirements.

Output Capacitor

The output ripple voltage ΔV_O of a buck converter can be expressed as

$$\Delta V_O = \Delta I_L \cdot \left(ESR + \frac{1}{8 \cdot F_{SW} \cdot C_O} \right) \quad (7)$$

where C_O is the output capacitance.

Since the inductor ripple current ΔI_L increases as D decreases (Equation (3)), the output ripple voltage is therefore the highest when V_{IN} is at its maximum.

A 10μF to 47μF X5R ceramic capacitor is found adequate for output filtering in most applications. Ripple current in the output capacitor is not a concern because the inductor current of a buck converter directly feeds C_O , resulting in very low ripple current. Avoid using Z5U and Y5V ceramic capacitors for output filtering because these types of capacitors have high temperature and high voltage coefficients.

Freewheeling Diode

Use of Schottky barrier diodes as freewheeling rectifiers reduces diode reverse recovery input current spikes, easing high-side current sensing in the SC4524B. These

Applications Information (Cont.)

diodes should have an average forward current rating at least 2A and a reverse blocking voltage of at least a few volts higher than the input voltage. For switching regulators operating at low duty cycles (i.e. low output voltage to input voltage conversion ratios), it is beneficial to use freewheeling diodes with somewhat higher average current ratings (thus lower forward voltages). This is because the diode conduction interval is much longer than that of the transistor. Converter efficiency will be improved if the voltage drop across the diode is lower.

The freewheeling diode should be placed close to the SW pin of the SC4524B to minimize ringing due to trace inductance. 10BQ015, 20BQ030 (International Rectifier), B220A (Diodes Inc.), SS13, SS22 (Vishay), CMSH1-20M, CMSH1-20ML and CMSH2-20M (Central-Semi.) are all suitable.

The freewheeling diode should be placed close to the SW pin of the SC4524B on the PCB to minimize ringing due to trace inductance.

Bootstrapping the Power Transistor

The minimum BST-SW voltage required to fully saturate the power transistor is shown in Figure 5, which is about 1.96V at room temperature.

The BST-SW voltage is supplied by a bootstrap circuit powered from either the input or the output of the converter (Figure 6). To maximize efficiency, tie the bootstrap diode to the converter output if $V_o > 2.5V$. Since the bootstrap supply current is proportional to the converter load current, using a lower voltage to power the bootstrap circuit reduces driving loss and improves efficiency.

For the bootstrap circuit, a fast switching PN diode (such as 1N4148 or 1N914) and a small ($0.1\mu F - 0.47\mu F$) ceramic capacitor is sufficient for most applications. When bootstrapping from 2.5V to 3.0V output voltages, use a low forward drop Schottky diode (BAT-54 or similar) for D1.

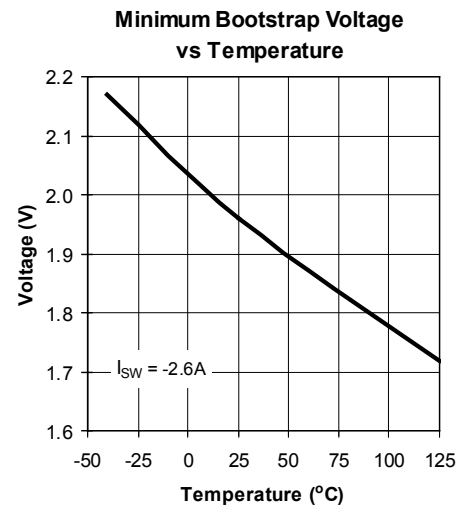

Figure 5. Typical Minimum Bootstrap Voltage required to Saturate Transistor ($I_{SW} = -2.6A$).

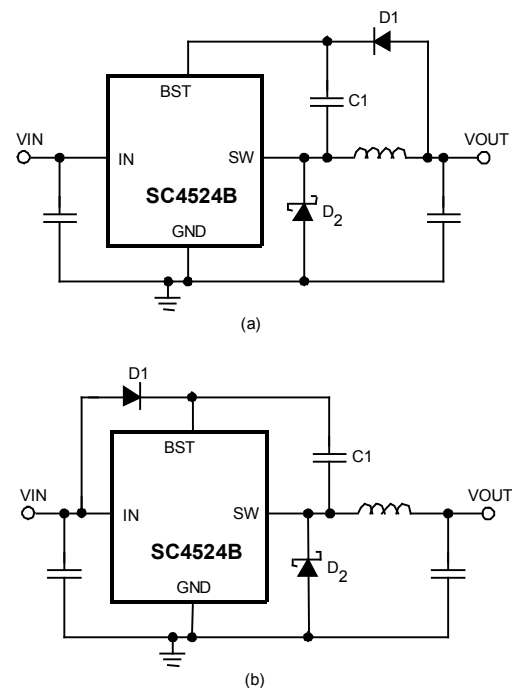

Figure 6. Methods of Bootstrapping the SC4524B

Loop Compensation

The goal of compensation is to shape the frequency response of the converter so as to achieve high DC accuracy and fast transient response while maintaining loop stability.

Applications Information (Cont.)

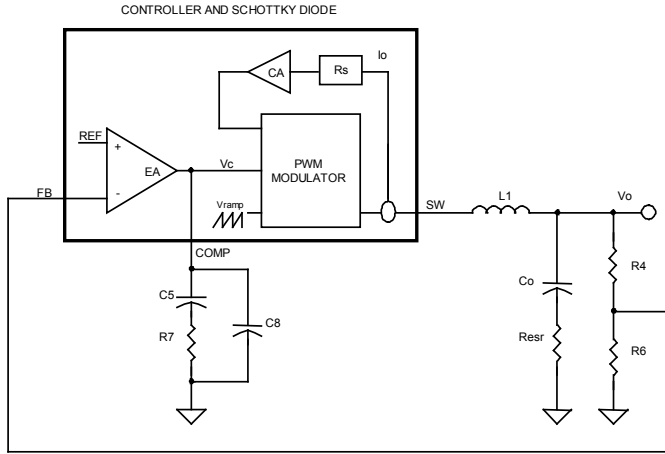

Figure 7. Block diagram of control loops

The block diagram in Figure 7 shows the control loops of a buck converter with the SC4524B. The inner loop (current loop) consists of a current sensing resistor ($R_s=6.1\text{m}\Omega$) and a current amplifier (CA) with gain ($G_{CA}=28$). The outer loop (voltage loop) consists of an error amplifier (EA), a PWM modulator, and a LC filter.

Since the current loop is internally closed, the remaining task for the loop compensation is to design the voltage compensator (C_5 , R_7 , and C_8).

For a converter with switching frequency F_{SW} output inductance L_1 , output capacitance C_o and loading R , the control (V_c) to output (V_o) transfer function in Figure 7 is given by:

$$\frac{V_o}{V_c} = \frac{G_{PWM}(1 + sR_{ESR}C_o)}{(1 + s/\omega_p)(1 + s/\omega_n Q + s^2/\omega_n^2)} \quad (8)$$

This transfer function has a finite DC gain

$$G_{PWM} \approx \frac{R}{G_{CA} \cdot R_s}$$

an ESR zero F_z at

$$\omega_z = \frac{1}{R_{ESR}C_o}$$

a dominant low-frequency pole F_p at

$$\omega_p \approx \frac{1}{RC_o}$$

and double poles at half the switching frequency.

Including the voltage divider (R_4 and R_6), the control to feedback transfer function is found and plotted in Figure 8 as the converter gain.

Since the converter gain has only one dominant pole at low frequency, a simple Type-2 compensation network is sufficient for voltage loop compensation. As shown in Figure 8, the voltage compensator has a low frequency integrator pole, a zero at F_{z1} , and a high frequency pole at F_{p1} . The integrator is used to boost the gain at low frequency. The zero is introduced to compensate the excessive phase lag at the loop gain crossover due to the integrator pole (-90deg) and the dominant pole (-90deg). The high frequency pole nulls the ESR zero and attenuates high frequency noise.

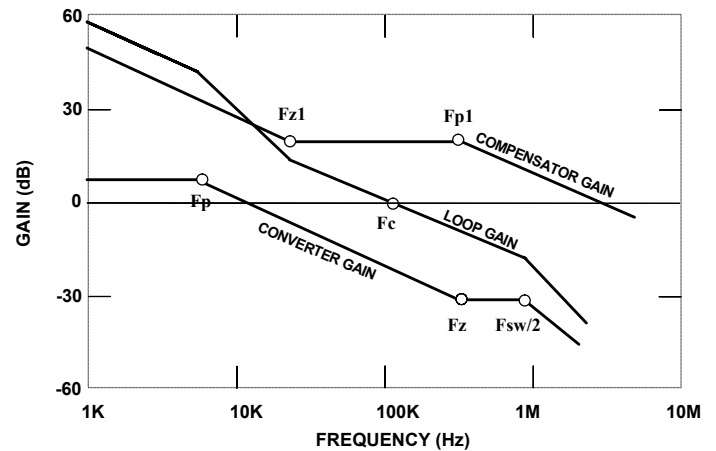

Figure 8. Bode plots for voltage loop design

Therefore, the procedure of the voltage loop design for the SC4524B can be summarized as:

- (1) Plot the converter gain, i.e. control to feedback transfer function.
- (2) Select the open loop crossover frequency, F_c , between 10% and 20% of the switching frequency. At F_c , find the required compensator gain, A_c . In typical applications with ceramic output capacitors, the ESR zero is neglected and the required compensator gain at F_c can be estimated by

$$A_c = -20 \cdot \log \left(\frac{1}{G_{CA} R_s} \cdot \frac{1}{2\pi F_c C_o} \cdot \frac{V_{FB}}{V_o} \right) \quad (9)$$

Applications Information (Cont.)

(3) Place the compensator zero, F_{z1} , between 10% and 20% of the crossover frequency, F_c .

(4) Use the compensator pole, F_{p1} , to cancel the ESR zero, F_z .

(5) Then, the parameters of the compensation network can be calculated by

$$R_7 = \frac{10^{\frac{A_c}{20}}}{g_m}$$

$$C_5 = \frac{1}{2\pi F_{z1} R_7}$$

$$C_8 = \frac{1}{2\pi F_{p1} R_7}$$

where $g_m = 0.28 \text{mA/V}$ is the EA gain of the SC4524B.

Example: Determine the voltage compensator for an 800kHz, 12V to 3.3V/2A converter with 22 μF ceramic output capacitor.

Choose a loop gain crossover frequency of 80kHz, and place voltage compensator zero and pole at $F_{z1} = 16\text{kHz}$ (20% of F_c), and $F_{p1} = 600\text{kHz}$. From Equation (9), the required compensator gain at F_c is

$$A_c = -20 \cdot \log\left(\frac{1}{28 \cdot 6.1 \cdot 10^{-3}} \cdot \frac{1}{2\pi \cdot 80 \cdot 10^3 \cdot 22 \cdot 10^{-6}} \cdot \frac{1.0}{3.3}\right) = 15.9 \text{dB}$$

Then the compensator parameters are

$$R_7 = \frac{10^{\frac{15.9}{20}}}{0.28 \cdot 10^{-3}} = 22.3 \text{k}$$

$$C_5 = \frac{1}{2\pi \cdot 16 \cdot 10^3 \cdot 22.1 \cdot 10^3} = 0.45 \text{nF}$$

$$C_8 = \frac{1}{2\pi \cdot 600 \cdot 10^3 \cdot 22.1 \cdot 10^3} = 12 \text{pF}$$

Select $R_7 = 22.1 \text{k}$, $C_5 = 0.47 \text{nF}$, and $C_8 = 10 \text{pF}$ for the design.

Compensator parameters for various typical applications are listed in Table 4. A MathCAD program is also available upon request for detailed calculation of the compensator parameters.

PCB Layout Considerations

In a step-down switching regulator, the input bypass

capacitor, the main power switch and the freewheeling diode carry pulse current (Figure 9). For jitter-free operation, the size of the loop formed by these components should be minimized. Since the power switch is already integrated within the SC4524B, connecting the anode of the freewheeling diode close to the negative terminal of the input bypass capacitor minimizes size of the switched current loop. The input bypass capacitor should be placed close to the IN pin. Shortening the traces of the SW and BST nodes reduces the parasitic trace inductance at these nodes. This not only reduces EMI but also decreases switching voltage spikes at these nodes.

The exposed pad should be soldered to a large ground plane as the ground copper acts as a heat sink for the device. To ensure proper adhesion to the ground plane, avoid using vias directly under the device.

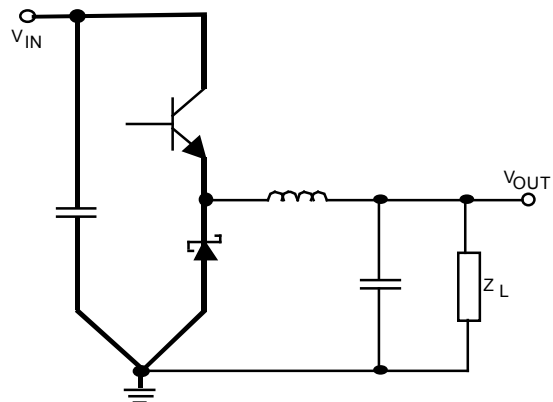

Figure 9. Heavy lines indicate the critical pulse current loop. The inductance of this loop should be minimized.

Recommended Component Parameters in Typical Applications

Table 4 lists the recommended inductance (L_1) and compensation network (R_7 , C_5 , C_8) for common input and output voltages. The inductance is determined by assuming that the ripple current is 35% of load current I_O . The compensator parameters are calculated by assuming a 22 μ F low ESR ceramic output capacitor and a loop gain crossover frequency of $F_{sw}/10$.

Table 4. Recommended inductance (L_1) and compensator (R_7 , C_5 , C_8)

Typical Applications					Recommended Parameters				
Vin(V)	Vo(V)	Io(A)	Fsw(kHz)	C2(μ F)	L1(μ H)	R7(k)	C5(nF)	C8(pF)	
3.3	1.5	1	500	22	6.8	6.65	2.2	10	
			1000		3.3	12.4	0.68		
		2	500		3.3	6.65	2.2		
			1000		1.5	12.4	0.68		
	2.5	1	500		4.7	22.1	0.68		
			1000		2.2	35.7	0.47		
		2	500		2.2	18.2	0.68		
			1000		1.5	35.7	0.47		
	5	1.5	1		500	6.8	6.65		2.2
					1000	3.3	12.7		0.68
			2		500	3.3	6.65		2.2
					1000	2.2	12.7		0.68
2.5		1	500	8.2	11.3	1.5			
			1000	4.7	23.7	0.47			
		2	500	4.7	11.3	1			
			1000	2.2	20	0.47			
3.3		1	500	6.8	15	0.82			
			1000	3.3	26.7	0.47			
		2	500	3.3	15	0.82			
			1000	2.2	29.4	0.47			
12	1.5	1	500	8.2	7.15	2.2			
			1000	4.7	7.15	2.2			
		2	500	15	11.3	1			
			1000	6.8	20	0.68			
	2.5	1	500	6.8	11.3	1			
			1000	3.3	20	0.47			
		2	500	15	15	0.82			
			1000	8.2	30.9	0.47			
	3.3	1	500	8.2	15	0.82			
			1000	4.7	30.9	0.47			
		2	500	15	23.7	0.68			
			1000	10	41.2	0.47			
	5	1	500	8.2	23.7	0.68			
			1000	4.7	45.3	0.47			
		2	500	15	35.7	0.68			
			1000	8.2	63.4	0.47			
	7.5	1	500	8.2	35.7	0.68			
			1000	4.7	63.4	0.47			
		2	500	10	42.2	0.68			
			1000	4.7	84.5	0.47			
	10	1	500	4.7	42.2	0.68			
			1000	2.2	84.5	0.47			
		2	500	4.7	42.2	0.68			
			1000	2.2	84.5	0.47			

Typical Application Schematics

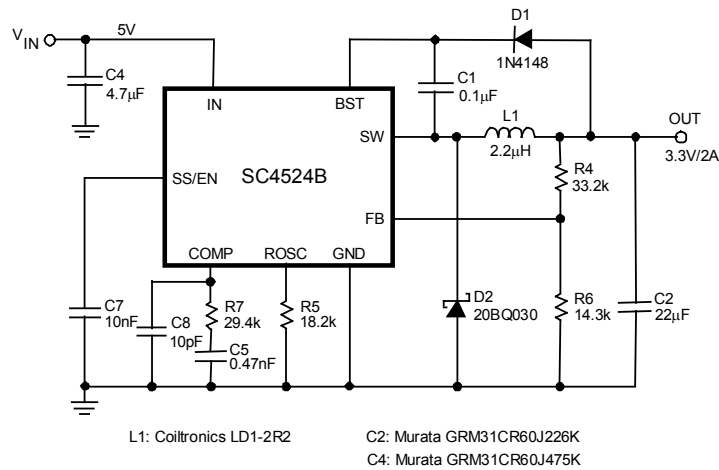

Figure 10. 1MHz 5V to 3.3V/2A Step-down Converter

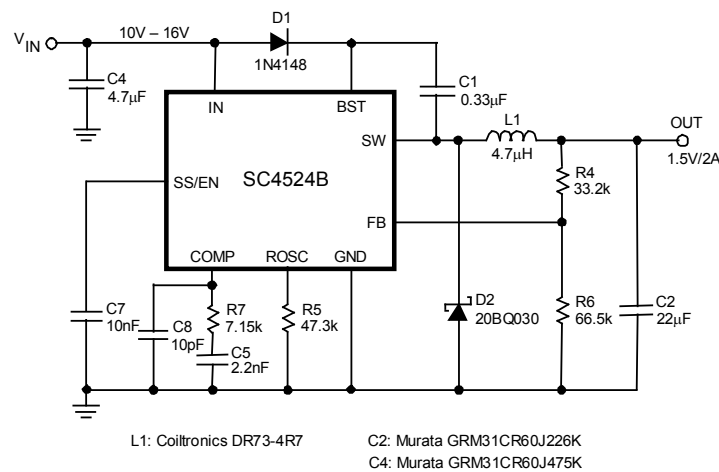

Figure 11. 500kHz 10V-16V to 1.5V/2A Step-down Converter

Typical Performance Characteristics

(For A 12V to 5V/2A Step-down Converter with 1MHz Switching Frequency)

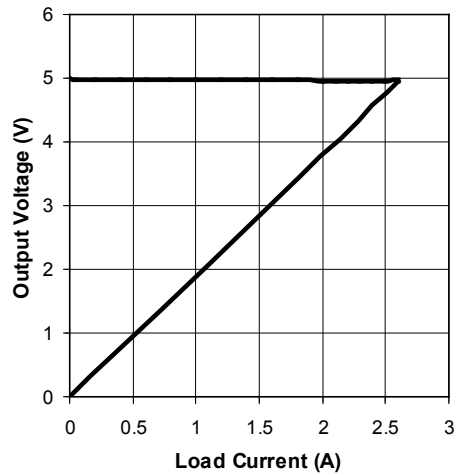

Figure 12(a). Load Characteristic

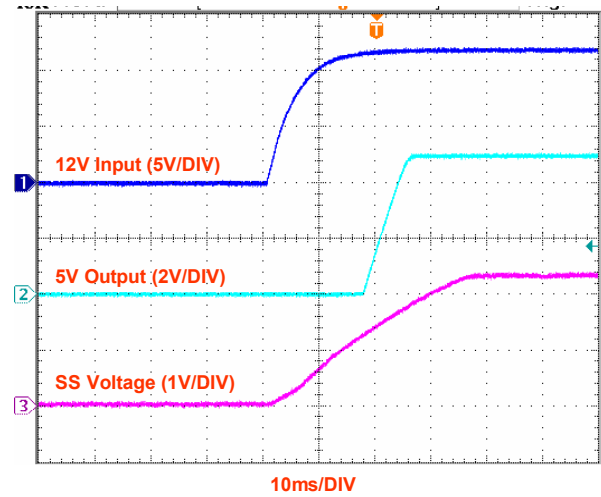

Figure 12(b). V_{IN} Start up Transient ($I_O=2A$)

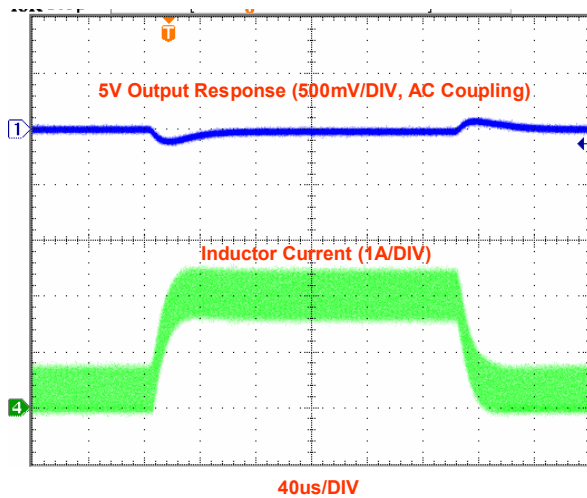

Figure 12(c). Load Transient Response
($I_O=0.3A$ to $2A$)

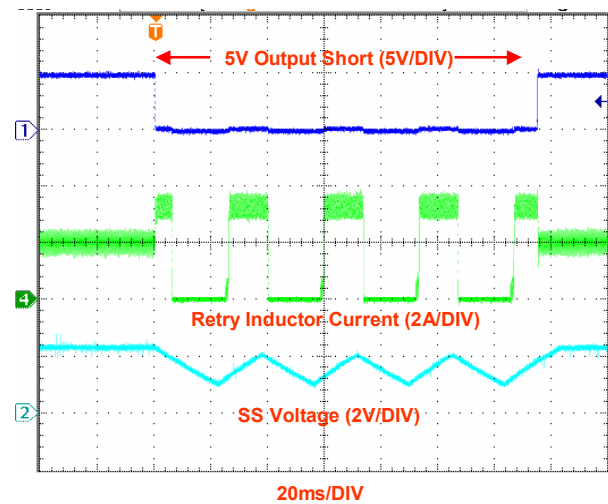
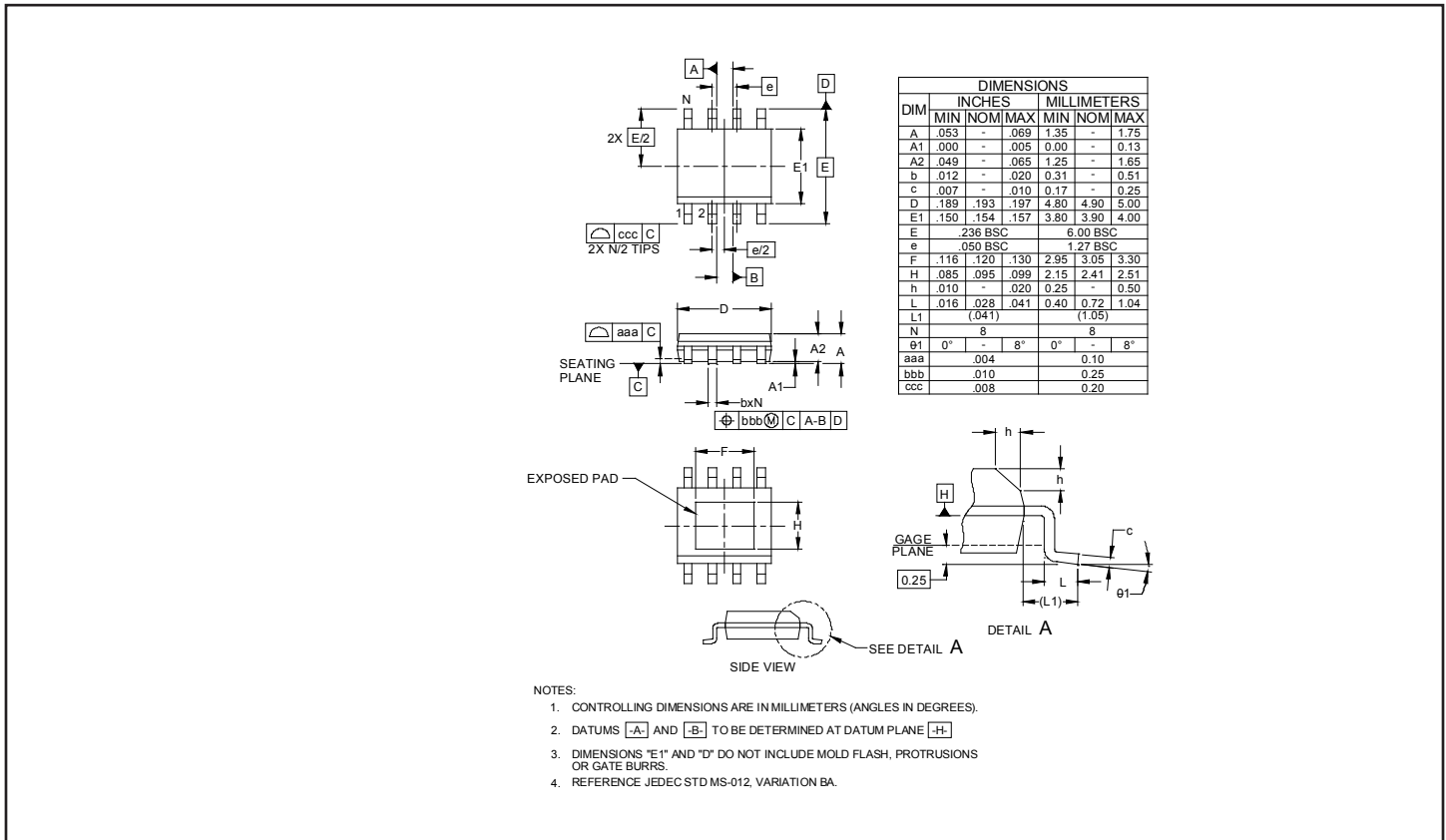
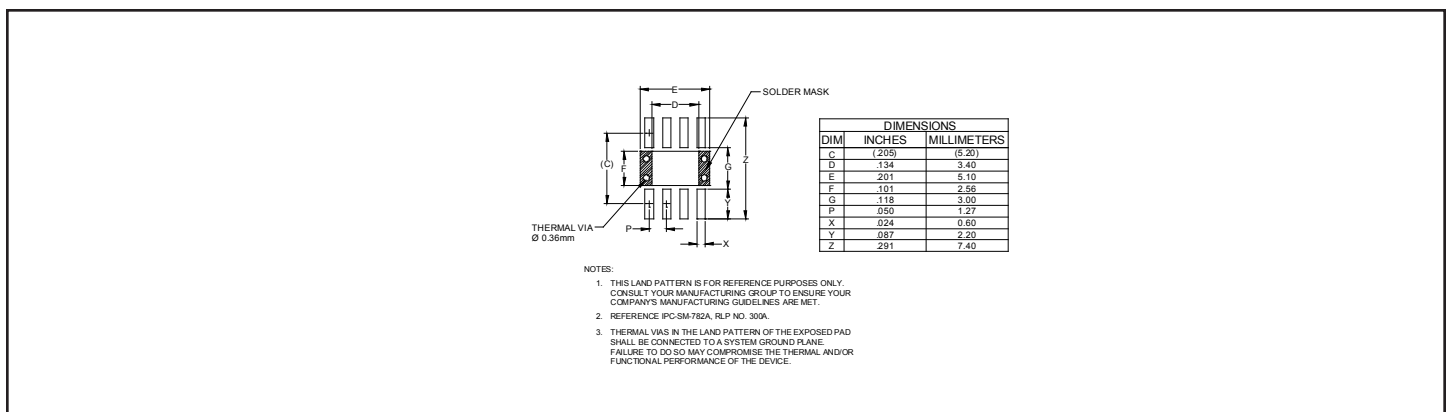

Figure 12(d). Output Short Circuit (Hiccup)

Outline Drawing - SOIC-8 EDP



Land Pattern - SOIC-8 EDP



Contact Information

Semtech Corporation
 Power Mangement Products Division
 200 Flynn Road, Camarillo, CA 93012
 Phone: (805) 498-2111 Fax: (805) 498-3804

Looking for pricing, stock, or lifecycle information?

Click below to explore more details on WIN SOURCE:

 [View SC4524BSETRT on WIN SOURCE](#)

 [Semtech Corporation](#) Information

Optimize Your Supply Chain with WIN SOURCE Solutions

-  Global Sourcing Solution
-  Obsolete Management
-  Cost Control Management
-  Shortage Management
-  Alternative Solution
-  Excess Inventory Management