



**THE DATASHEET OF
SCA100T-D01-1**



Data Sheet



THE SCA100T DUAL AXIS INCLINOMETER SERIES

The SCA100T Series is a 3D-MEMS-based dual axis inclinometer family that provides instrumentation grade performance for leveling applications. The measuring axes of the sensing elements are parallel to the mounting plane and orthogonal to each other. Low temperature dependency, high resolution and low noise, together with a robust sensing element design, make the SCA100T the ideal choice for leveling instruments. The Murata inclinometers are insensitive to vibration, due to their over damped sensing elements, and can withstand mechanical shocks of up to 20000 g.

Features

- Dual axis inclination measurement (X and Y)
- Measuring ranges $\pm 30^\circ$ SCA100T-D01 and $\pm 90^\circ$ SCA100T-D02
- 0.0035° resolution (10 Hz BW, analog output)
- Sensing element controlled over damped frequency response (-3dB 18Hz)
- Robust design, high shock durability (20000g)
- High stability over temperature and time
- Single +5 V supply
- Ratiometric analog voltage outputs
- Digital SPI inclination and temperature output
- Comprehensive failure detection features
 - True self test by deflecting the sensing elements' proof mass by electrostatic force.
 - Continuous sensing element interconnection failure check.
 - Continuous memory parity check.
- RoHS compliant
- Compatible with Pb-free reflow solder process

Applications

- Platform leveling and stabilization
- 360° vertical orientation measurement
- Leveling instruments
- Construction levels

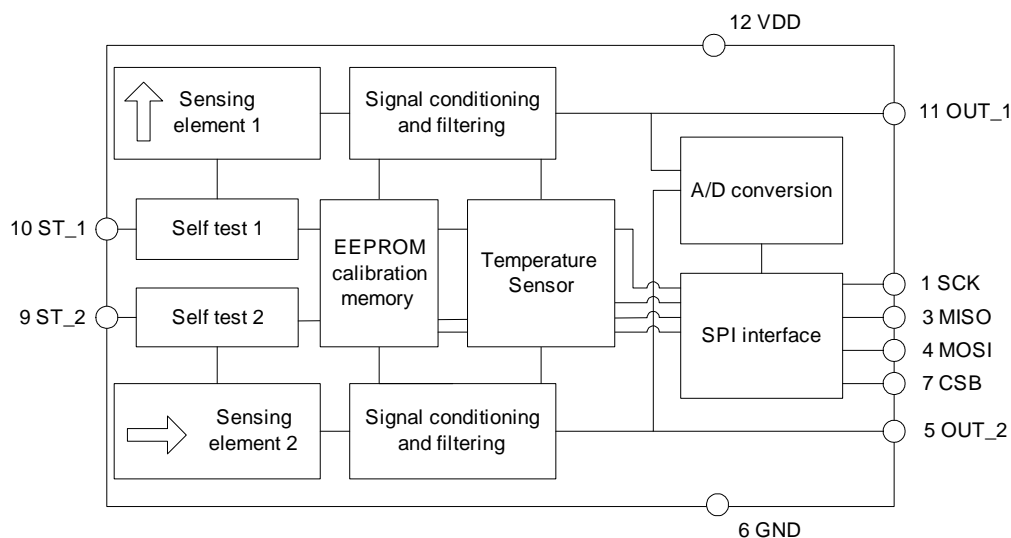

Figure 1. Functional block diagram

TABLE OF CONTENTS

The SCA100T Dual Axis Inclinometer Series	1
Features.....	1
Applications	1
Table of Contents.....	2
1 Electrical Specifications	3
1.1 Absolute Maximum Ratings	3
1.2 Performance Characteristics.....	3
1.3 Electrical Characteristics	4
1.4 SPI Interface DC Characteristics.....	4
1.5 SPI Interface AC Characteristics.....	4
1.6 SPI Interface Timing Specifications.....	5
1.7 Electrical Connection.....	6
1.8 Typical Performance Characteristics	6
1.8.1 Additional External Compensation	7
2 Functional Description	9
2.1 Measuring Directions.....	9
2.2 Voltage to Angle Conversion	9
2.3 Ratiometric Output.....	10
2.4 SPI Serial Interface.....	10
2.5 Digital Output to Angle Conversion.....	12
2.6 Self Test and Failure Detection Modes	13
2.7 Temperature Measurement	14
3 Application Information	15
3.1 Recommended Circuit Diagrams and Printed Circuit Board Layouts	15
3.2 Recommended Printed Circuit Board Footprint	16
4 Mechanical Specifications and Reflow Soldering	16
4.1 Mechanical Specifications (Reference only)	16
4.2 Reflow Soldering.....	17

1 Electrical Specifications

The SCA100T product family comprises two versions, the SCA100T-D01 and the SCA100T-D02 that differ in measurement range. The product version specific performance specifications are listed in the table SCA100T performance characteristics below. All other specifications are common with both versions. V_{dd}=5.00V and ambient temperature unless otherwise specified.

1.1 Absolute Maximum Ratings

Supply voltage (V _{DD})	-0.3 V to +5.5V
Voltage at input / output pins	-0.3V to (V _{DD} + 0.3V)
Storage temperature	-55°C to +125°C
Operating temperature	-40°C to +125°C
Mechanical shock	Drop from 1 meter onto a concrete surface (20000g). Powered or non-powered
ESD Protection:	
-Human Body Model	±2 kV
-Charge Device Model	±500 V
Cleaning	Ultrasonic cleaning not allowed

1.2 Performance Characteristics

Parameter	Condition	SCA100T -D01	SCA100T -D02	Units
Measuring range	Nominal	±30	±90	°
		±0.5	±1.0	g
Frequency response	-3dB LP ⁽¹⁾	8-28	8-28	Hz
Offset (Output at 0g)	Ratiometric output	V _{dd} /2	V _{dd} /2	V
Offset calibration error		±0.11	±0.23	°
Offset Digital Output		1024	1024	LSB
Sensitivity		4	2	V/g
	between 0...1° ⁽²⁾	70	35	mV/°
Sensitivity calibration error		±0.5	±0.5	%
Sensitivity Digital Output		1638	819	LSB / g
Offset temperature dependency	-25...85°C (typical)	±0.008	±0.008	°/°C
	-40...125°C (max)	±0.86	±0.86	°
Sensitivity temperature dependency	-25...85°C (typical)	±0.014	±0.014	%/°C
	-40...125°C (max)	-2.5...+1	-2.5...+1	%
Typical non-linearity	Measuring range	±0.11	±0.57	°
Digital output resolution		11	11	Bits
	between 0...1° ⁽²⁾	0.035	0.07	° / LSB
Output noise density	From DC...100Hz	0.0008	0.0008	° / √Hz
Analog output resolution ⁽⁴⁾	Bandwidth 10 Hz ⁽³⁾	0.0035	0.0035	°
Ratiometric error ⁽⁴⁾	V _{dd} = 4.75...5.25V	±2	±2	%
Cross-axis sensitivity	Max.	4	4	%

Note 1. The frequency response is determined by the sensing element's internal gas damping.

Note 2. The angle output has SIN curve relationship to voltage output

Note 3. 1st degree low pass filtered output Resolution = Noise density * √(bandwidth*1.6)

Note 4. Typical value for most of the components

1.3 Electrical Characteristics

Parameter	Condition	Min.	Typ	Max.	Units
Supply voltage Vdd		4.75	5.0	5.25	V
Current consumption	Vdd = 5 V; No load		4	5	mA
Operating temperature		-40		+125	°C
Analog resistive output load	Vout to Vdd or GND	10			kOhm
Analog capacitive output load	Vout to Vdd or GND			20	nF
Start-up delay	Reset and parity check			10	ms

1.4 SPI Interface DC Characteristics

Parameter	Conditions	Symbol	Min	Typ	Max	Unit
Input terminal CSB						
Pull up current	$V_{IN} = 0\text{ V}$	I_{PU}	13	22	35	μA
Input high voltage		V_{IH}	4		Vdd+0.3	V
Input low voltage		V_{IL}	-0.3		1	V
Hysteresis		V_{HYST}		0.23*Vdd		V
Input capacitance		C_{IN}		2		pF
Input terminal MOSI, SCK						
Pull down current	$V_{IN} = 5\text{ V}$	I_{PD}	9	17	29	μA
Input high voltage		V_{IH}	4		Vdd+0.3	V
Input low voltage		V_{IL}	-0.3		1	V
Hysteresis		V_{HYST}		0.23*Vdd		V
Input capacitance		C_{IN}		2		pF
Output terminal MISO						
Output high voltage	$I > -1\text{ mA}$	V_{OH}	Vdd-0.5			V
Output low voltage	$I < 1\text{ mA}$	V_{OL}			0.5	V
Tristate leakage	$0 < V_{MISO} < V_{dd}$	I_{LEAK}		5	100	pA

1.5 SPI Interface AC Characteristics

Parameter	Condition	Min.	Typ.	Max.	Units
Output load	@500kHz			1	nF
SPI clock frequency				500	kHz
Internal A/D conversion time			150		μs
Data transfer time for 8bit command and 11bit data	@500kHz		38		μs

1.6 SPI Interface Timing Specifications

Parameter	Conditions	Symbol	Min.	Typ.	Max.	Unit
Terminal CSB, SCK						
Time from CSB (10%) to SCK (90%)		T_{LS1}	120			ns
Time from SCK (10%) to CSB (90%)		T_{LS2}	120			ns
Terminal SCK						
SCK low time	Load capacitance at MISO < 2 nF	T_{CL}	1			μ s
SCK high time	Load capacitance at MISO < 2 nF	T_{CH}	1			μ s
Terminal MOSI, SCK						
Time from changing MOSI (10%, 90%) to SCK (90%). Data setup time		T_{SET}	30			ns
Time from SCK (90%) to changing MOSI (10%,90%). Data hold time		T_{HOL}	30			ns
Terminal MISO, CSB						
Time from CSB (10%) to stable MISO (10%, 90%).	Load capacitance at MISO < 15 pF	T_{VAL1}	10		100	ns
Time from CSB (90%) to high impedance state of MISO.	Load capacitance at MISO < 15 pF	T_{LZ}	10		100	ns
Terminal MISO, SCK						
Time from SCK (10%) to stable MISO (10%, 90%).	Load capacitance at MISO < 15 pF	T_{VAL2}			100	ns
Terminal CSB						
Time between SPI cycles, CSB at high level (90%)		T_{LH}	15			μ s
When using SPI commands RDAX, RDAY, RWTR: Time between conversion cycles, CSB at high level (90%)		TLH	150			μ s

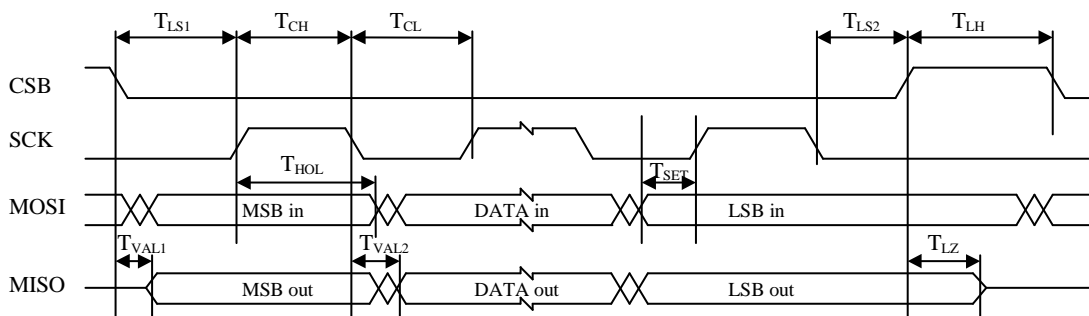

Figure 2. Timing diagram for SPI communication

1.7 Electrical Connection

If the SPI interface is not used SCK (pin1), MISO (pin3), MOSI (pin4) and CSB (pin7) must be left floating. Self-test can be activated applying logic “1” (positive supply voltage level) to ST_1 or ST_2 pins (pins 10 or 9). Self-test must not be activated for both channels at the same time. If ST feature is not used pins 9 and 10 must be left floating or connected to GND. Inclination signals are provided from pins OUT_1 and OUT_2.

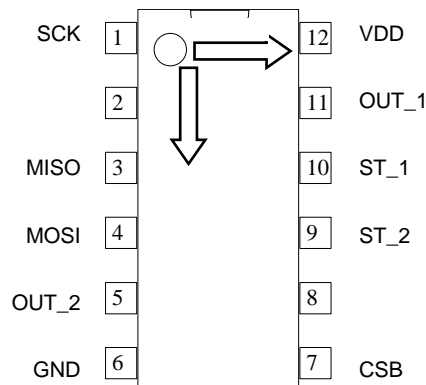

Figure 3. SCA100T electrical connection

No.	Node	I/O	Description
1	SCK	Input	Serial clock
2	NC	Input	No connect, left floating
3	MISO	Output	Master in slave out; data output
4	MOSI	Input	Master out slave in; data input
5	Out_2	Output	Y axis Output (Ch 2)
6	GND	Supply	Ground
7	CSB	Input	Chip select (active low)
8	NC	Input	No connect, left floating
9	ST_2	Input	Self test input for Ch 2
10	ST_1	Input	Self test input for Ch 1
11	Out_1	Output	X axis Output (Ch 1)
12	VDD	Supply	Positive supply voltage (+5V DC)

1.8 Typical Performance Characteristics

Typical offset and sensitivity temperature dependencies of the SCA100T are presented in following diagrams. These results represent the typical performance of SCA100T components. The mean value and 3 sigma limits (mean \pm 3 \times standard deviation) and specification limits are presented in following diagrams. The 3 sigma limits represents 99.73% of the SCA100T population.

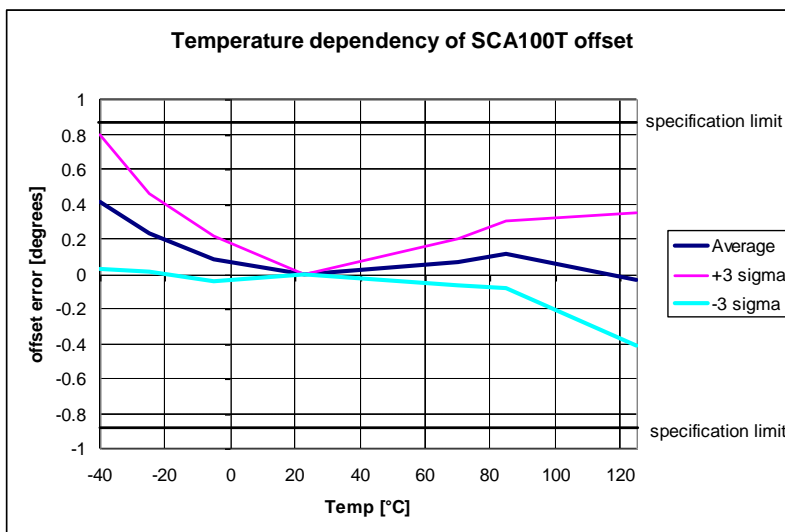

Figure 4. Typical temperature dependency of SCA100T offset

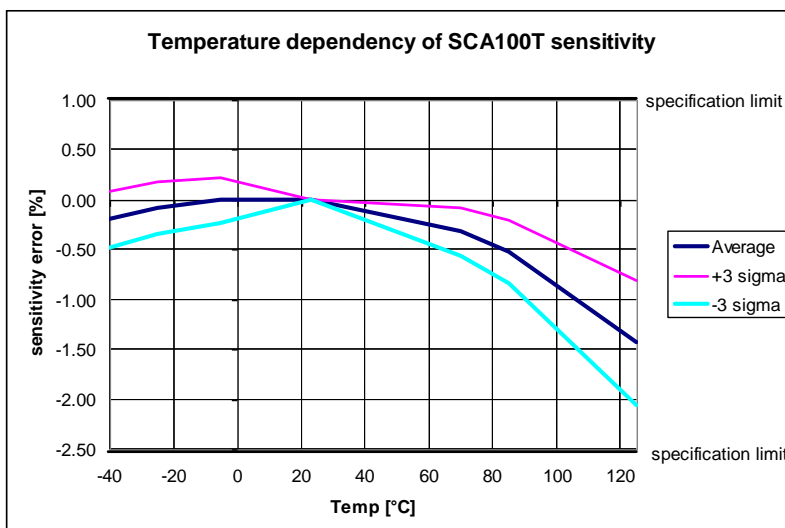

Figure 5. Typical temperature dependency of SCA100T sensitivity

1.8.1 Additional External Compensation

To achieve the best possible accuracy, the temperature measurement information and typical temperature dependency curves can be used for SCA100T offset and sensitivity temperature dependency compensation. The equation of fitted 3rd order polynome curve for offset compensation is:

$$Offcorr = -0.0000006 * T^3 + 0.0001 * T^2 - 0.0039 * T + 0.0522$$

Where:

Offcorr: 3rd order polynome fitted to average offset temperature dependency curve
 T: temperature in °C (Refer to paragraph 2.7 Temperature Measurement)

The calculated compensation curve can be used to compensate the temperature dependency of the SCA100T offset by using following equation:

$$OFFSET_{comp} = Offset - Offcorr$$

Where:

OFFSET_{comp}: temperature compensated offset in degrees
 Offset: Nominal offset in degrees

The equation of fitted 2nd order polynome curve for sensitivity compensation is:

$$Scorr = -0.00011 * T^2 + 0.0022 * T + 0.0408$$

Where:

Scorr: 2nd order polynome fitted to average sensitivity temperature dependency curve
 T temperature in °C

The calculated compensation curve can be used to compensate the temperature dependency of the SCA100T sensitivity by using following equation:

$$SENScomp = SENS * (1 + Scorr / 100)$$

Where:

SENScomp temperature compensated sensitivity
 SENS Nominal sensitivity (4V/g SCA100T-D01, 2V/g SCA100T-D02)

The typical offset and sensitivity temperature dependency after external compensation is shown in the pictures below.

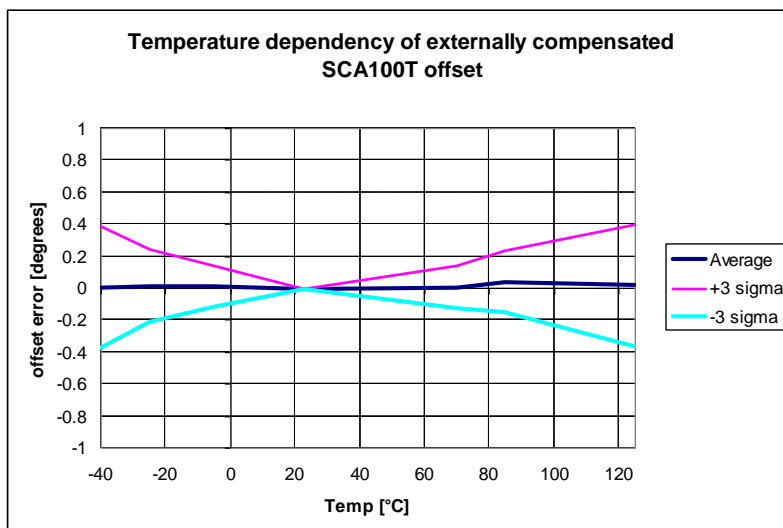

Figure 6. The temperature dependency of an externally compensated SCA100T offset

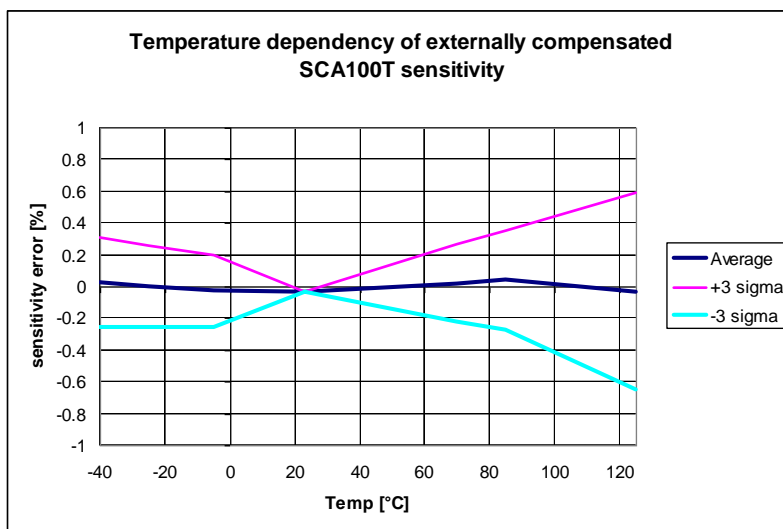

Figure 7. The temperature dependency of an externally compensated SCA100T sensitivity

2 Functional Description

2.1 Measuring Directions

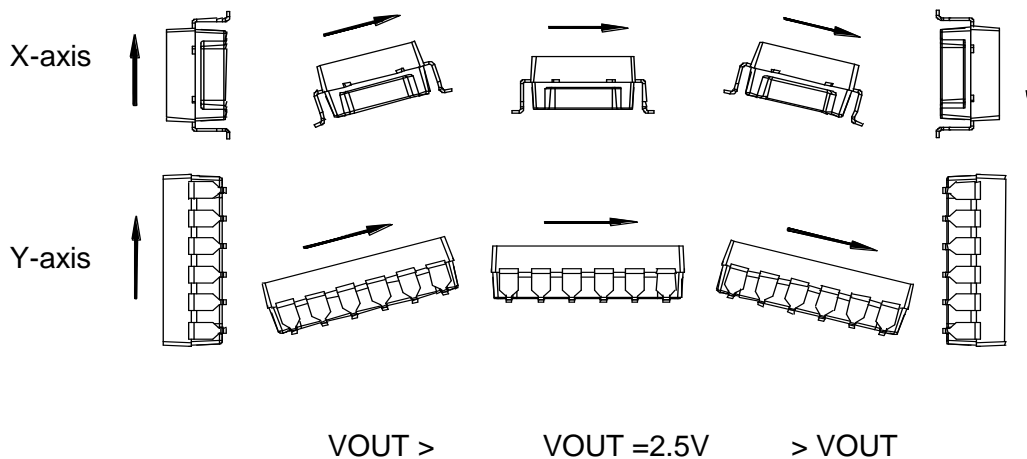

Figure 8. The measuring directions of the SCA100T

2.2 Voltage to Angle Conversion

Analog output can be transferred to angle using the following equation for conversion:

$$\alpha = \arcsin\left(\frac{V_{out} - Offset}{Sensitivity}\right)$$

where: Offset = output of the device at 0° inclination position, Sensitivity is the sensitivity of the device and V_{Dout} is the output of the SCA100T. The nominal offset is 2.5 V and the sensitivity is 4 V/g for the SCA100T-D01 and 2 V/g for the SCA100T-D02.

Angles close to 0° inclination can be estimated quite accurately with straight line conversion but for the best possible accuracy, arcsine conversion is recommended to be used. The following table shows the angle measurement error if straight line conversion is used.

Straight line conversion equation:

$$\alpha = \frac{V_{out} - Offset}{Sensitivity}$$

Where: Sensitivity = 70mV/° with SCA100T-D01 or Sensitivity= 35mV/° with SCA100T-D02

Tilt angle [°]	Straight line conversion error [°]
0	0
1	0.0027
2	0.0058
3	0.0094
4	0.0140
5	0.0198
10	0.0787
15	0.2185
30	1.668

2.3 Ratiometric Output

Ratiometric output means that the zero offset point and sensitivity of the sensor are proportional to the supply voltage. If the SCA100T supply voltage is fluctuating the SCA100T output will also vary. When the same reference voltage for both the SCA100T sensor and the measuring part (A/D-converter) is used, the error caused by reference voltage variation is automatically compensated for.

2.4 SPI Serial Interface

A Serial Peripheral Interface (SPI) system consists of one master device and one or more slave devices. The master is defined as a micro controller providing the SPI clock and the slave as any integrated circuit receiving the SPI clock from the master. The ASIC in Murata Electronics' products always operates as a slave device in master-slave operation mode.

The SPI has a 4-wire synchronous serial interface. Data communication is enabled by a low active Slave Select or Chip Select wire (CSB). Data is transmitted by a 3-wire interface consisting of wires for serial data input (MOSI), serial data output (MISO) and serial clock (SCK).

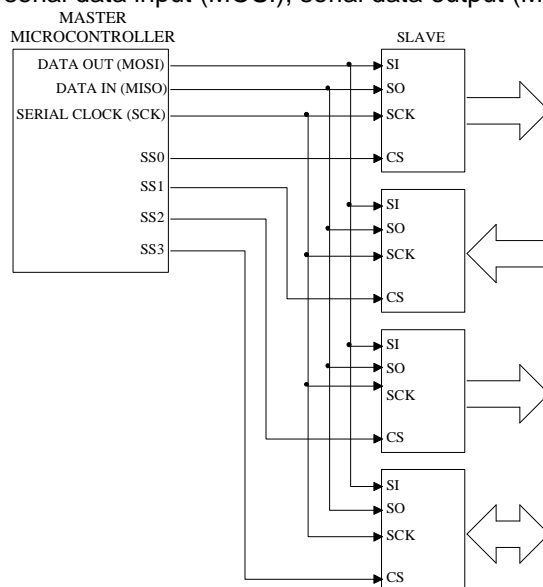

Figure 9. Typical SPI connection

The SPI interface in Murata products is designed to support any micro controller that uses SPI bus. Communication can be carried out by either a software or hardware based SPI. Please note that in the case of hardware based SPI, the received acceleration data is 11 bits. The data transfer uses the following 4-wire interface:

MOSI	master out slave in	$\mu\text{P} \rightarrow \text{SCA100T}$
MISO	master in slave out	$\text{SCA100T} \rightarrow \mu\text{P}$
SCK	serial clock	$\mu\text{P} \rightarrow \text{SCA100T}$
CSB	chip select (low active)	$\mu\text{P} \rightarrow \text{SCA100T}$

Each transmission starts with a falling edge of CSB and ends with the rising edge. During transmission, commands and data are controlled by SCK and CSB according to the following rules:

- commands and data are shifted; MSB first, LSB last
- each output data/status bits are shifted out on the falling edge of SCK (MISO line)

- each bit is sampled on the rising edge of SCK (MOSI line)
- after the device is selected with the falling edge of CSB, an 8-bit command is received. The command defines the operations to be performed
- the rising edge of CSB ends all data transfer and resets internal counter and command register
- if an invalid command is received, no data is shifted into the chip and the MISO remains in high impedance state until the falling edge of CSB. This reinitializes the serial communication.
- data transfer to MOSI continues immediately after receiving the command in all cases where data is to be written to SCA100T's internal registers
- data transfer out from MISO starts with the falling edge of SCK immediately after the last bit of the SPI command is sampled in on the rising edge of SCK
- maximum SPI clock frequency is 500kHz
- maximum data transfer speed for RDAX or RDAY is 5300 samples per sec for one channel at 500kHz clock
- maximum data transfer speed for RDAX and RDAY is 4150 samples per sec for two channel at 500kHz clock

SPI command can be either an individual command or a combination of command and data. In the case of combined command and data, the input data follows uninterruptedly the SPI command and the output data is shifted out parallel with the input data.

The SPI interface uses an 8-bit instruction (or command) register. The list of commands is given in Table below.

Command name	Command format	Description:
MEAS	00000000	Measure mode (normal operation mode after power on)
RWTR	00001000	Read temperature data register
STX	00001110	Activate Self test for X-channel
STY	00001111	Activate Self test for Y-channel
RDAX	00010000	Read X-channel acceleration
RDAY	00010001	Read Y-channel acceleration

Measure mode (MEAS) is standard operation mode after power-up. During normal operation, the MEAS command is the exit command from Self test.

Read temperature data register (RWTR) reads temperature data register during normal operation without affecting the operation. The temperature data register is updated every 150 μ s. The load operation is disabled whenever the CSB signal is low, hence CSB must stay high at least 150 μ s prior to the RWTR command in order to guarantee correct data. The data transfer is presented in Figure 10 below. The data is transferred MSB first. In normal operation, it does not matter what data is written into temperature data register during the RWTR command and hence writing all zeros is recommended.

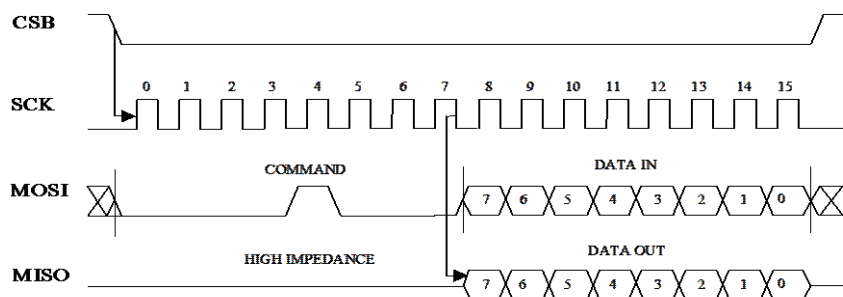

Figure 10. Command and 8 bit temperature data transmission over the SPI

Self test for X-channel (STX) activates the self test function for the X-channel (Channel 1). The internal charge pump is activated and a high voltage is applied to the X-channel acceleration sensor element electrode. This causes the electrostatic force that deflects the beam of the sensing element and simulates the acceleration to the positive direction. The self-test is de-activated by giving the MEAS command. **The self test function must not be activated for both channels at the same time.**

Self test for Y-channel (STY) activates the self test function for the Y-channel (Channel 2). The internal charge pump is activated and a high voltage is applied to the Y-channel acceleration sensor element electrode.

Read X-channel acceleration (RDAX) accesses the AD converted X-channel (Channel 1) acceleration signal stored in acceleration data register X.

Read Y-channel acceleration (RDAY) accesses the AD converted Y-channel (Channel 2) acceleration signal stored in acceleration data register Y.

During normal operation, acceleration data registers are reloaded every 150 μ s. The load operation is disabled whenever the CSB signal is low, hence CSB must stay high at least 150 μ s prior the RDAX command in order to guarantee correct data. Data output is an 11-bit digital word that is fed out MSB first and LSB last.

Recommended read cycle for X-,Y-channel and temperature:

1. Wait (150 μ s)
2. RDAX (38 μ s)
3. Wait (15 μ s)
4. RDAY (38 μ s)
5. Wait (15 μ s)
6. RWTR (32 μ s)
7. Goto 1.

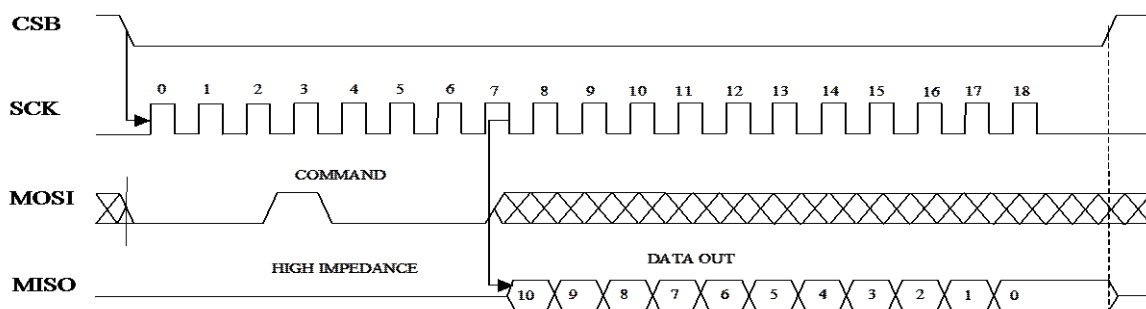

Figure 11. Command and 11 bit acceleration data transmission over the SPI

2.5 Digital Output to Angle Conversion

The acceleration measurement results in RDAX and RDAY data registers are in 11 bit digital word format. The data range is from 0 to 2048. The nominal content of RDAX and RDAY data registers in zero angle position are:

Binary: 100 0000 0000

Decimal: 1024

The transfer function from differential digital output to angle can be presented as

$$\alpha = \arcsin\left(\frac{D_{out}[\text{LSB}] - D_{out@0^\circ}[\text{LSB}]}{Sens[\text{LSB/g}]}\right)$$

where;

- D_{out} digital output (RDAX or RDAY)
- $D_{out@0^\circ}$ digital offset value, nominal value = 1024
- α angle
- $Sens$ sensitivity of the device. (SCA100T-D01: 1638, SCA100T-D02: 819)

As an example following table contains data register values and calculated differential digital output values with -5, -1 0, 1 and 5 degree tilt angles.

Angle [°]	Acceleration [mg]	RDAX (SCA100T-D01)	RDAX (SCA100T-D02)
-5	-87.16	dec: 881 bin: 011 0111 0001	dec: 953 bin: 011 1011 1001
-1	-17.45	dec: 995 bin: 011 1110 0011	dec: 1010 bin: 011 1111 0010
0	0	dec: 1024 bin: 100 0000 0000	dec: 1024 bin: 100 0000 0000
1	17.45	dec: 1053 bin: 100 0001 1101	dec: 1038 bin: 100 0000 1110
5	87.16	dec: 1167 bin: 100 1000 1111	dec: 1095 bin: 100 0100 0111

2.6 Self Test and Failure Detection Modes

To ensure reliable measurement results the SCA100T has continuous interconnection failure and calibration memory validity detection. A detected failure forces the output signal close to power supply ground or VDD level, outside the normal output range.

The calibration memory validity is verified by continuously running parity check for the control register memory content. In the case where a parity error is detected, the control register is automatically re-loaded from the EEPROM. If a new parity error is detected after re-loading data both analog output voltages are forced to go close to ground level (<0.25 V) and SPI outputs go below 102 counts.

The SCA100T also includes a separate self test mode. The true self test simulates acceleration, or deceleration, using an electrostatic force. The electrostatic force simulates acceleration that is high enough to deflect the proof mass to the extreme positive position, and this causes the output signal to go to the maximum value. The self test function is activated either by a separate on-off command on the self test input, or through the SPI. To ensure that output goes to positive end product must be in 0g position. For position below 0g output change might be limited to +1g change of the output.

The self-test generates an electrostatic force, deflecting the sensing element's proof mass, thus checking the complete signal path. The true self test performs following checks:

- Sensing element movement check
- ASIC signal path check
- PCB signal path check
- Micro controller A/D and signal path check

The created deflection can be seen in both the SPI and analogue outputs. The self test function is activated digitally by a STX or STY command, and de-activated by a MEAS command. Self test can be also activated applying logic "1" (positive supply voltage level) to ST pins (pins 9 & 10) of SCA100T. The self test Input high voltage level is 4 – Vdd+0.3 V and input low voltage level is 0.3 – 1 V. **The self test function must not be activated for both channels at the same time.**

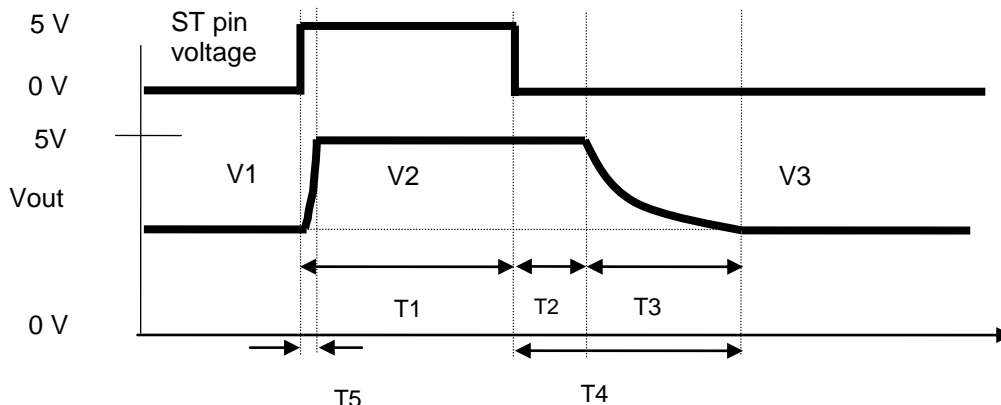

Figure 12. Self test wave forms

V1 = initial output voltage before the self test function is activated.

V2 = output voltage during the self test function.

V3 = output voltage after the self test function has been de-activated and after stabilization time
Please note that the error band specified for V3 is to guarantee that the output is within 5% of the initial value after the specified stabilization time. After a longer time (max. 1 second) V1=V3.

T1 = Pulse length for Self test activation

T2 = Saturation delay

T3 = Recovery time

T4 = Stabilization time =T2+T3

T5 = Rise time during self test.

Self test characteristics:

T1 [ms]	T2 [ms]	T3 [ms]	T4 [ms]	T5 [ms]	V2:	V3:
20-100	Typ. 25	Typ. 30	Typ. 55	Typ. 15	Min 0.95*VDD (4.75V @Vdd=5V)	0.95*V1-1.05*V1

2.7 Temperature Measurement

The SCA100T has an internal temperature sensor, which is used for internal offset compensation. The temperature information is also available for additional external compensation. The temperature sensor can be accessed via the SPI interface and the temperature reading is an 8-bit word (0...255). The transfer function is expressed with the following formula:

$$T = \frac{Counts - 197}{-1.083}$$

Where:

Counts Temperature reading
T Temperature in °C

The temperature measurement output is not calibrated. The internal temperature compensation routine uses relative results where absolute accuracy is not needed. If the temperature measurement results are used for additional external compensation then one point calibration in the system level is needed to remove the offset. With external one point calibration the accuracy of the temperature measurement is about ± 1 °C.

3 Application Information

3.1 Recommended Circuit Diagrams and Printed Circuit Board Layouts

The SCA100T should be powered from a well regulated 5 V DC power supply. Coupling of digital noise to the power supply line should be minimized. 100nF filtering capacitor between VDD pin 12 and GND plane must be used. If regulator is placed far from component for example other PCB it is recommend adding more capacitance between VDD and GND to ensure current drive capability of the system. For example 470 pF and 1uF capacitor can be used.

The SCA100T has a ratiometric output. To get the best performance use the same reference voltage for both the SCA100T and Analog/Digital converter.

Use low pass RC filters with 5.11 k Ω and 10nF on the SCA100T outputs to minimize clock noise.

Locate the 100nF power supply filtering capacitor close to VDD pin 12. Use as short a trace length as possible. Connect the other end of capacitor directly to the ground plane. Connect the GND pin 6 to underlying ground plane. Use as wide ground and power supply planes as possible. Avoid narrow power supply or GND connection strips on PCB.

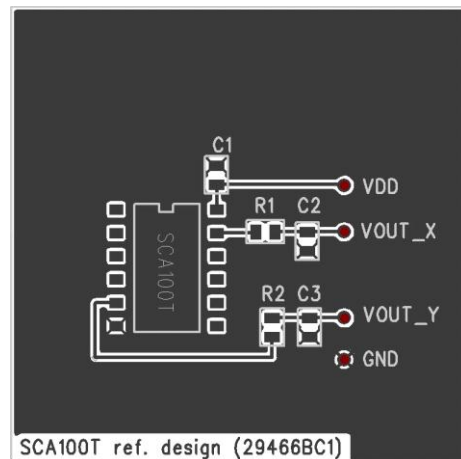
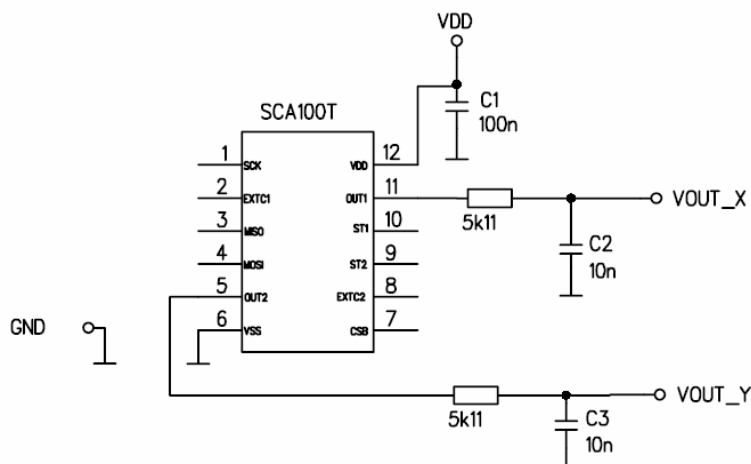

Figure 13. Analog connection and layout example

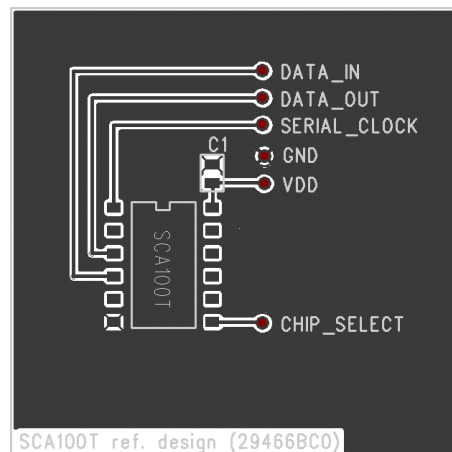
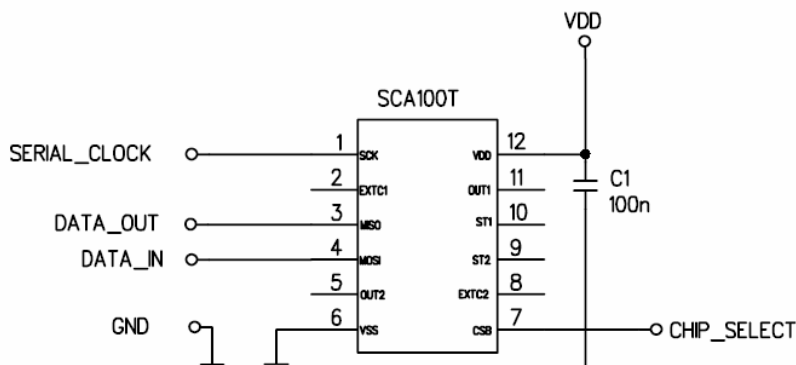

Figure 14. SPI connection example

3.2 Recommended Printed Circuit Board Footprint

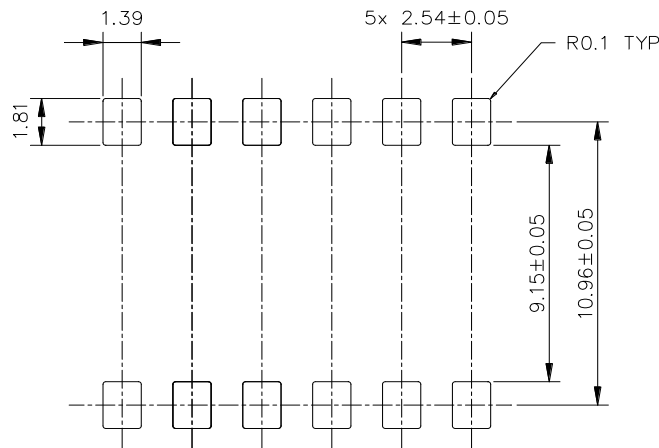

Figure 15. Recommended PCB footprint

4 Mechanical Specifications and Reflow Soldering

4.1 Mechanical Specifications (Reference only)

Lead frame material:	Copper
Plating:	Nickel followed by Gold
Solderability:	JEDEC standard: JESD22-B102-C
RoHS compliance:	RoHS compliant lead free component.
Co-planarity error	0.1mm max.
The part weights	<1.2 g

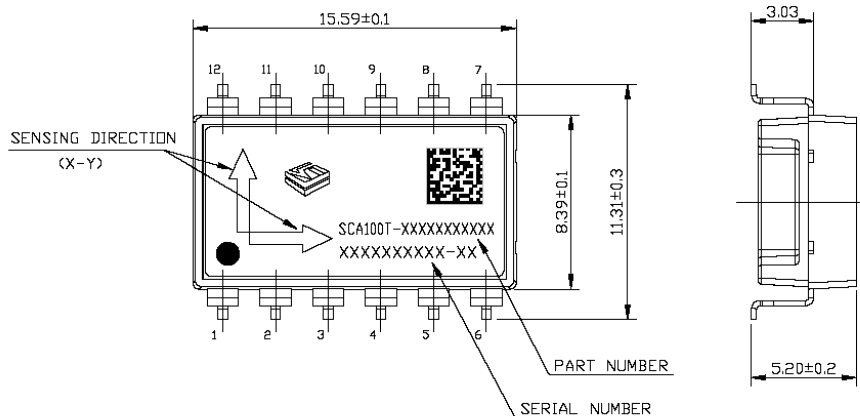

Figure 16. Mechanical dimensions of the SCA100T (Dimensions in mm)

4.2 Reflow Soldering

The SCA100T is suitable for Sn-Pb eutectic and Pb-free soldering process and mounting with normal SMD pick-and-place equipment.

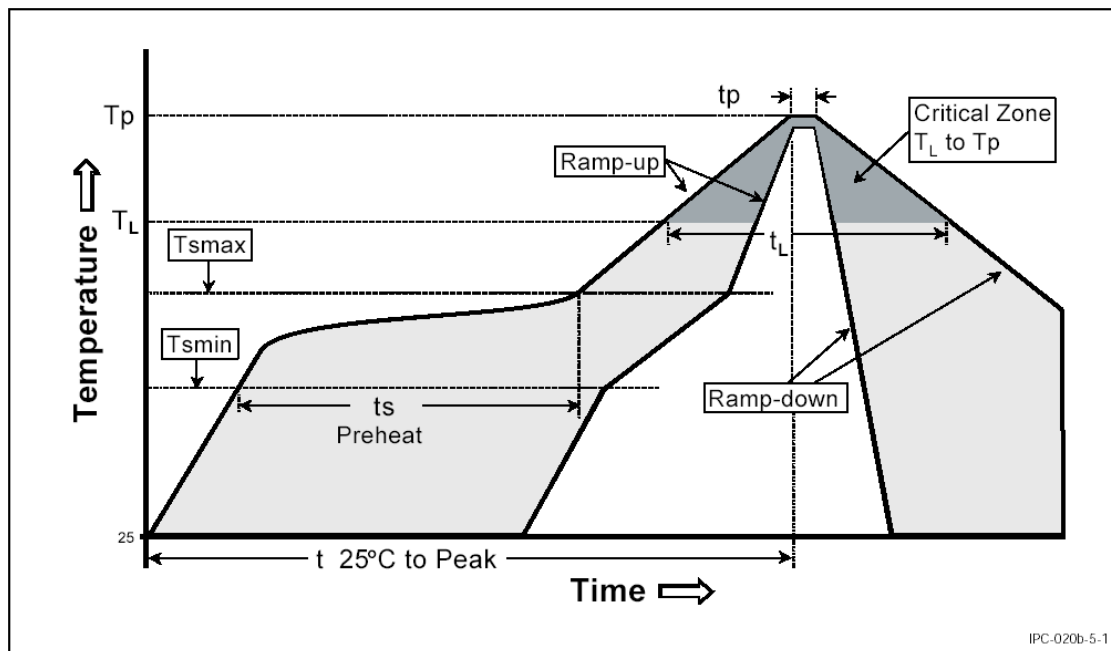

Figure 17. Recommended SCA100T body temperature profile during reflow soldering. Ref. IPC/JEDEC J-STD-020B.

Profile feature	Sn-Pb Eutectic Assembly	Pb-free Assembly
Average ramp-up rate (T_L to T_P)	3°C/second max.	3°C/second max.
Preheat		
- Temperature min (T_{smin})	100°C	150°C
- Temperature max (T_{smax})	150°C	200°C
- Time (min to max) (t_s)	60-120 seconds	60-180 seconds
T_{smax} to T_L , Ramp up rate		3°C/second max
Time maintained above:		
- Temperature (T_L)	183°C	217°C
- Time (t_L)	60-150 seconds	60-150 seconds
Peak temperature (T_P)	240 +0/-5°C	250 +0/-5°C
Time within 5°C of actual Peak Temperature (T_P)	10-30 seconds	20-40 seconds
Ramp-down rate	6°C/second max	6°C/second max
Time 25° to Peak temperature	6 minutes max	8 minutes max



The Moisture Sensitivity Level of the part is 3 according to the IPC/JEDEC J-STD-020B. The part should be delivered in a dry pack. The manufacturing floor time (out of bag) in the customer's end is 168 hours.

Notes:

- Preheating time and temperatures according to guidance from solder paste manufacturer.
- It is important that the part is parallel to the PCB plane and that there is no angular alignment error from intended measuring direction during assembly process.
- Wave soldering is not recommended.
- **Ultrasonic cleaning is not allowed.** The sensing element may be damaged by an ultrasonic cleaning process

Looking for pricing, stock, or lifecycle information?

Click below to explore more details on WIN SOURCE:

-  [View SCA100T-D01-1 on WIN SOURCE](#)
-  [Murata Electronics North America Information](#)

Optimize Your Supply Chain with WIN SOURCE Solutions

-  Global Sourcing Solution
-  Obsolete Management
-  Cost Control Management
-  Shortage Management
-  Alternative Solution
-  Excess Inventory Management