



CD2481

Programmable Four-Channel Communications Controller

Datasheet

The CD2481 is a four-channel synchronous/asynchronous communications controller specifically designed to reduce host-system processing overhead and increase efficiency in a wide variety of communications applications. A special member of the CD24X1 family, the device allows easy field upgrades and enhancement with an on-chip 8K-word microcode store for downloaded control code. The CD2481 is packaged in a 100-pin MQFP package that offers 10 data/clock/modem pins per channel. The device has four fully independent serial channels to support standard asynchronous, PPP, MNP[®]4, SLIP, bit-synchronous (HDLC), and byte-synchronous (bisync, X.21) protocols. *The device is non-functional until the microcode is downloaded; only a small boot ROM with code to perform device initialization is included.*

The device is based on a proprietary on-chip RISC processor that performs all the time-critical, low-level tasks otherwise performed by the host system.

The CD2481 boosts system efficiency with eight on-chip DMA channels, on-chip FIFOs (16 bytes/direction), intelligent vectored interrupts, and intelligent protocol processing. The on-chip DMA controller provides 'fire-and-forget' transmit support — the host need only inform the CD2481 of the location of the packet to send. Similarly, on receive, the CD2481 automatically receives a complete packet with no host intervention or assistance. The DMA controller also has a transmit 'Append mode' for use in asynchronous applications.

The DMA controller uses a dual-buffer scheme that easily implements simple or complex buffer schemes. Each channel and direction in the dual-buffer scheme has two active buffers.

The CD2481 can be programmed to interrupt the host at the completion of a frame or buffer. In applications where buffers are of a small, fixed size, the dual-buffer scheme allows large frames to be divided into multiple buffers.

For applications where a DMA interface is not desired, the device can be operated as either interrupt-driven or polled. This choice is available for each channel and each direction. For example, a channel can be programmed for DMA transmit and interrupt-driven receive. In either case, 16-byte FIFOs on each channel and in each direction reduce latency time requirements, making both software and hardware designs less time-critical. Threshold levels on the FIFOs are user-programmable.

Vectored interrupts are another way the CD2481 helps system efficiency. Separate interrupts are generated for transmit, receive, and modem-signal/timer changes with unique, user-defined vectors for each type and channel. This allows very flexible interfacing and fast, efficient interrupt coding. For example, the Good Data[™] interrupt allows the host to vector directly to a routine that transfers the receive data — no status or error checking is required.



Information in this document is provided in connection with Intel® products. No license, express or implied, by estoppel or otherwise, to any intellectual property rights is granted by this document. Except as provided in Intel's Terms and Conditions of Sale for such products, Intel assumes no liability whatsoever, and Intel disclaims any express or implied warranty, relating to sale and/or use of Intel products including liability or warranties relating to fitness for a particular purpose, merchantability, or infringement of any patent, copyright or other intellectual property right. Intel products are not intended for use in medical, life saving, or life sustaining applications.

Intel may make changes to specifications and product descriptions at any time, without notice.

Designers must not rely on the absence or characteristics of any features or instructions marked "reserved" or "undefined." Intel reserves these for future definition and shall have no responsibility whatsoever for conflicts or incompatibilities arising from future changes to them.

The CD2481 may contain design defects or errors known as errata which may cause the product to deviate from published specifications. Current characterized errata are available on request.

Contact your local Intel sales office or your distributor to obtain the latest specifications and before placing your product order.

Copies of documents which have an ordering number and are referenced in this document, or other Intel literature may be obtained by calling 1-800-548-4725 or by visiting Intel's website at <http://www.intel.com>.

Copyright © Intel Corporation, 2001

*Third-party brands and names are the property of their respective owners.

Contents

1.0	Features	9
1.1	Benefits	11
1.2	CD2XXX Device Family Compatibility	12
2.0	Conventions	13
2.1	Abbreviations	13
2.2	Acronyms	14
3.0	Pin Information	15
3.1	Pin Diagram — CD2481	15
3.2	Pin Functions — CD2481	16
3.3	Pin Descriptions	16
4.0	Register Summaries	20
4.1	Memory Map	20
4.1.1	Global Registers	20
4.1.2	Option Registers	21
4.1.3	Bit Rate and Clock Option Registers	22
4.1.4	Channel Command and Status Registers	22
4.1.5	Interrupt Registers	22
4.1.6	DMA Registers	24
4.1.7	Timer Registers	25
4.2	Register Definitions	25
4.2.1	Global Registers	25
4.2.2	Option Registers	25
4.2.3	Bit Rate and Clock Option Registers	29
4.2.4	Channel Command and Status Registers	29
4.2.5	Interrupt Registers	31
4.2.6	DMA Registers	34
4.2.7	Timer Registers	35
5.0	Functional Description	37
5.1	Host Interface	37
5.1.1	Host Read and Write Cycles	37
5.1.2	Byte and Word Transfers	39
5.2	Interrupts	39
5.2.1	Contexts and Channels	40
5.2.2	Interrupt Registers	40
5.2.3	Groups and Types	41
5.2.4	Hardware Signals and IACK Cycles	42
5.3	FIFO and Timer Operations	44
5.3.1	Receive FIFO Operation	44
5.3.2	Transmit FIFO Operation	44
5.3.3	Timers	44
5.3.4	Timers in Synchronous Protocols	45
5.3.5	Timers in Asynchronous Protocols	45
5.3.6	Transmit Timer	45

5.4	DMA Operation	45
5.4.1	Bus Acquisition Cycle.....	46
5.4.2	DMA Data Transfer	46
5.4.3	Bus Error Handling.....	47
5.4.4	A and B Buffers and Chaining.....	48
5.4.5	Transmit DMA Transfer.....	49
5.4.6	Synchronous Transmitter Examples	50
5.4.7	Receive DMA Transfer.....	52
5.5	Bit Rate Generation and Data Encoding.....	60
5.6	Hardware Configurations	67
5.6.1	Interface to a 32-Bit Data Bus.....	68
5.6.2	DMA Connections for the CD2481.....	68
5.6.3	Recommended CD2481 as a DTE and DCE Interface	68
6.0	Microcode Download.....	70
6.1	Microcode Download Information.....	70
6.1.1	Registers Specific to Download Operations.....	70
6.1.2	Download Code Example.....	71
7.0	Protocol Processing	75
7.1	HDLC Processing.....	75
7.1.1	FCS (Frame Check Sequence).....	75
7.1.2	HDLC Transmit Mode.....	75
7.1.3	HDLC Receive Mode	76
7.2	PPP (Point-to-Point Protocol) Mode.....	77
7.2.1	Character Format	77
7.2.2	Frame Format	77
7.2.3	FCS (Frame Check Sequence).....	77
7.2.4	Transparency	78
7.2.5	Definition of a Valid Frame.....	79
7.2.6	Transmitter	79
7.2.7	Receiver	80
7.3	SLIP Processing.....	81
7.3.1	Framing	81
7.3.2	Debugging Aids.....	82
7.4	MNP4_/ARAP Protocol Processing.....	82
7.4.1	Framing	82
7.4.2	MNP4_/ARAP FCS (Frame Check Sequence) Calculation.....	83
7.5	Async Processing.....	83
7.5.1	Transmitter In-Band Flow Control	83
7.5.2	Receiver In-Band Flow Control	84
7.5.3	Out-of-Band Flow Control	85
7.5.4	Line Break Detection and Generation	86
7.5.5	Special Character Transmission	86
7.5.6	Special Character Recognition.....	87
7.5.7	Special Character Range	87
7.5.8	UNIX Support Features	88
7.6	Bisync Protocol	92
7.6.1	Bisync Transmit Processing.....	92
7.6.2	Bisync Receive Processing.....	92

7.6.3	CRC Calculation in Bisync Mode	93
7.6.4	BCC Computation Formulas	94
7.6.5	Receive State Tables	95
7.7	X.21 Call Set-Up Mode.....	97
7.7.1	X.21 Transmit	97
7.7.2	X.21 Receive	97
7.8	Extended X.21 Mode.....	99
7.8.1	Extended X.21 Transmit.....	99
7.8.2	Extended X.21 Receive.....	99
7.9	Programmable Sync.....	100
7.9.1	Programmable Sync Transmit.....	101
7.9.2	Programmable Sync Receive.....	101
7.10	Non-8-Bit Data Transfers	102
8.0	Programming Examples	103
8.1	Global Initialization	105
8.2	Async Interrupt Setup Example.....	107
8.3	HDLC DMA Channel Setup Example.....	107
8.4	Receive DMA Interrupt Service Routine.....	109
8.5	Transmit Interrupt Service Routine.....	110
8.6	Support Files from the Intel FTP Server.....	110
9.0	Detailed Register Descriptions	112
9.1	Global Registers.....	112
9.1.1	Global Firmware Revision Code Register (GFRCR)	112
9.1.2	Channel Access Register (CAR)	112
9.2	Option Registers.....	113
9.2.1	Channel Mode Register (CMR)	113
9.2.2	Channel Option Register 1 (COR1).....	114
9.2.3	Channel Option Register 2 (COR2).....	116
9.2.4	Channel Option Register 3 (COR3).....	123
9.2.5	Channel Option Register 4 (COR4).....	130
9.2.6	Channel Option Register 5 (COR5).....	131
9.2.7	Channel Option Register 6 (COR6).....	132
9.2.8	Channel Option Register 7 (COR7).....	135
9.2.9	Special Character Registers – Async and Programmable Sync Modes	136
9.2.10	Special Character Range – Async Mode Only	138
9.2.11	LNext Character (LNXT) – Async Mode Only	139
9.2.12	Receive Frame Address Registers – HDLC Sync Mode Only	139
9.2.13	CRC Polynomial Select Register (CPSR)	141
9.2.14	Transmit Special Mapped Characters – PPP Mode only	141
9.2.15	Transmit Async Control Character Maps – Async-HDLC/PPP Mode Only	142
9.2.16	Receive Async Control Character Maps – Async-HDLC/PPP Mode Only	143
9.3	Bit Rate and Clock Option Registers.....	145
9.3.1	Receive Baud Rate Generator Registers	145
9.3.2	Transmit Baud Rate Generator Registers	146
9.4	Channel Command and Status Registers.....	148
9.4.1	Channel Command Register (CCR).....	148

9.4.2	Special Transmit Command Register (STCR)	150
9.4.3	Channel Status Register (CSR)	153
9.4.4	Modem Signal Value Registers (MSVR)	158
9.5	Interrupt Registers.....	159
9.5.1	General Interrupt Registers.....	159
9.5.2	Receive Interrupt Registers.....	163
9.5.3	Transmit Interrupt Registers.....	175
9.5.4	Modem Interrupt Registers.....	179
9.6	DMA Registers	182
9.6.1	DMA Mode Register (DMR)	182
9.6.2	Bus Error Retry Count (BERCNT).....	182
9.6.3	DMA Buffer Status (DMABSTS).....	183
9.6.4	DMA Receive Registers	184
9.6.5	DMA Transmit Registers	189
9.7	Timer Registers.....	197
9.7.1	Timer Period Register (TPR).....	197
9.7.2	Receive Time-Out Period Register (RTPR) – Async Modes Only	197
9.7.3	General Timer 1 (GT1) – Sync Modes Only.....	198
9.7.4	General Timer 2 (GT2) – Sync Modes Only.....	199
9.7.5	Transmit Timer Register (TTR) – Async Modes Only	200
10.0	Electrical Specifications	201
10.1	Absolute lectri Maximum Ratings (Revision B at 35 MHz)	201
10.2	DC Electrical Characteristics (Revision B at 35 MHz)	201
10.3	AC Electrical Characteristics (Revision B at 35 MHz)	202
10.4	Absolute Maximum Ratings (Revisions B and D at 60 MHz)	203
10.5	DC Electrical Characteristics (Revisions B and D at 60 MHz)	204
10.6	AC Electrical Characteristics (Revisions B and D at 60 MHz)	205
11.0	Package Specifications	215
12.0	Ordering Information Example	216
Index	217

Figures

1	Functional Block Diagram	11
2	Host Read Cycle	38
3	Host Write Cycle	39
4	Interrupt Acknowledge Cycle	41
5	Bus Acquisition Cycle.....	47
6	Data Transfer Timing	47
7	Transmitter A and B Buffers.....	50
8	Receiver A and B Buffers.....	53
9	DMA Transmit Buffer Selection.....	57
10	Bit Rate Generator/DPLL	62
11	Data Encoding.....	66
12	Transmit Data With External Clock In	66
13	Transmit Data With External Clock Out	66

14	DMA Connections for the CD2481	68
15	Character Format	77
16	Point-to-Point Protocol Frame	77
17	ARAP 1.0 Frame	83
18	ARAP 2.0 Frame	83
19	CD2481 Receive Character Processing.....	89
20	Initialization Sequence for the CD2481	104
21	CLK / BUSCLK / RESET* Timing Relationship.....	206
22	Slave Read Cycle Timing.....	207
23	Slave Write Cycle Timing	208
24	Interrupt Acknowledge Cycle Timing.....	209
25	Bus Arbitration Cycle Timing	210
26	Bus Release Timing	211
27	Bus Release Timing	212
28	DMA Read Cycle Timing.....	213
29	DMA Write Cycle Timing	214

Tables

1	Pin Descriptions	17
2	Transmit and Receive Interrupt Service Requests.....	42
3	A and B Buffers and Chaining	48
4	Clock Source Select	62
5	Bit Rate Constants, CLK = 25 MHz	63
6	Bit Rate Constants, CLK = 30 MHz	63
7	Bit Rate Constants, CLK = 35 MHz	64
8	Bit Rate Constants, CLK = 60 MHz	64
9	Data Clock Selection Using External Clock.....	67
10	DTE Connections	68
11	DCE Connections.....	69
12	Special Character Definition.....	82
13	SSPC[x] Settings.....	87
14	SCdet[x] Settings.....	87
15	Bisync Receive State Transition (see “Key” on page 96).....	95
16	ETC Byte Sequence	97
17	Byte Format - ETC Bit Set.....	99



Revision History

Revision	Date	Description
1.0	May 2001	Initial release.

1.0 Features

- Four full-duplex multi-protocol channels, each running up to 230.4 kbps (with 60-MHz clock)
- Microcode downloadable to on-chip storage supports various asynchronous and synchronous protocols on all channels
- 32-bit address, 16-bit data, double-buffered DMA (direct memory access) controller for each transmitter and receiver; two independent bit-rate generators per channel for transmit and receive
- On-chip NRZ (nonreturn-to-zero), NRZI (nonreturn-to-zero inverted), and Manchester data encoding and decoding
- DPLL (digital phase locked loop) on each receiver
- Two independent timers per channel

Protocols Supported

PPP (Point-to-Point Protocol) Features

- Supports data link level — RFC-1661
- Supports dual async control character maps (32 control characters) — RFC-1662
- Compatible with ISO 3309/4335 Addendum 1
- Automatic insertion/deletion of control/escape characters and bit complements
- Automatic generation and detection of 16-bit FCS (frame check sequence)

HDLC/SDLC (Non-Multidrop) Features

- Four 8-bit or two 16-bit frame address matching
- FCS generation and validation
- Programmable leading-pad character transmission
- Supports shared flags on receive frames
- Programmable number of leading flags

Asynchronous Features

- User-programmable and automatic flow control modes
 - In-band (software) by XON/XOFF
 - Out-of-band (hardware flow control) by RTS/CTS and DTR/DSR
- Line-break detection and generation
- Special-character and character-range recognition and transmission
- Transmit delay
- 5- to 8-bit character plus optional parity

- Enhanced features for UNIX[®] environment
 - Character expansion in transmit (for example, sending <LF> expands to <CR> <LF> automatically)
 - Programmable translation of receiving character with error to different pattern
 - Flow-control transparency and LNext

MNP[®] 4 V.42 Features

- AppleTalk[®] Remote Access protocol 1.0/2.0

SLIP Features

- Supports data link level — RFC-1055

Bisync Features

- Supports ASCII or EBCDIC encoding
- Supports transparent Bisync
- Recognition of all special characters enabling:
 - Block separation
 - CRC generation and validation
- Chaining of long receive blocks into multiple buffers

X.21 Features

- Full support for X.21 protocol
- Detection of steady-state conditions
- Transmission of steady-state conditions synchronized to modem lead
- Programmable SYN character, 1 or 2 SYN detect option
- Idle in any line condition

Programmable Sync Features

- Programmable for 5-, 6-, 7-, and 8-bit characters
- User-defined SYN (2) and EOF (4) characters
- Allows use in almost any character-sync environment

DMA Controller Features

- Dual configuration register sets to reduce realtime constraints
- Append (async only) and Block mode DMA
- Chain/unchain long frames into multiple buffers
- 32-bit address and 8- or 16-bit data transfer

Other Features

- Improved interrupt schemes
 - Vectored interrupts per channel allow direct jump into proper service routines
 - Good Data™ interrupts eliminate need for status checks
- Easily cascaded for multiple-device configurations
- 16-byte receive and transmit FIFOs
- Programmable Big- or Little-endian orientation
- Ten data / clock / modem control signals per channel

Figure 1. Functional Block Diagram

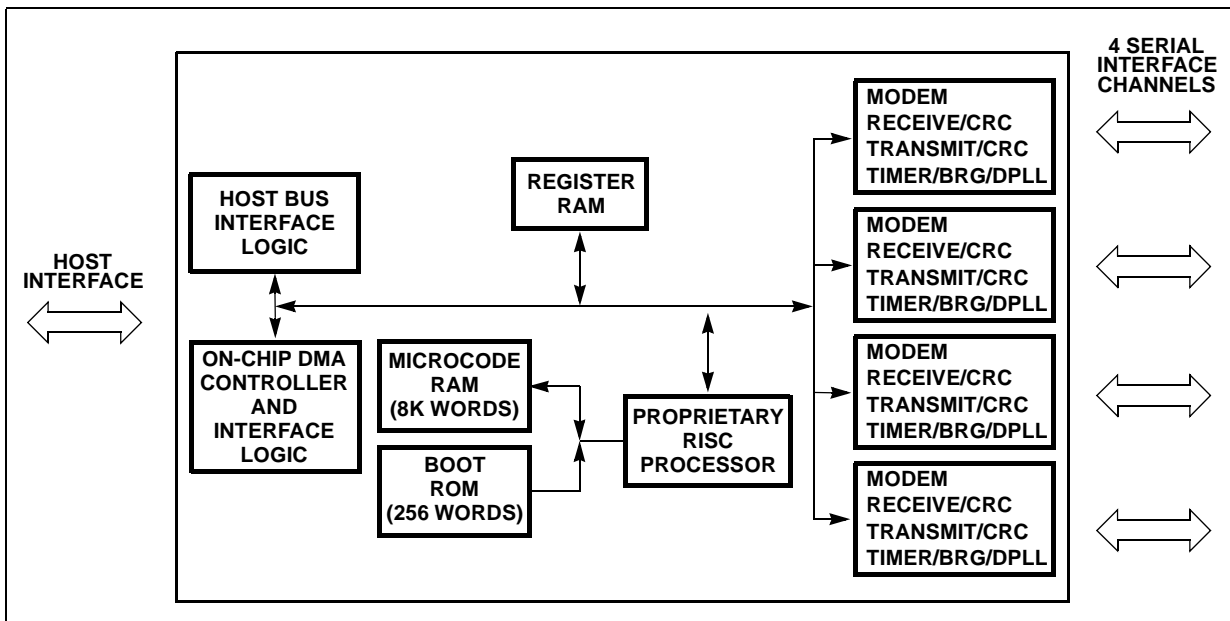

1.1 Benefits

- Substantially reduced host CPU overhead resulting in more channels and faster overall throughput
- No time-critical host software enabling faster and easier software development
- Smallest possible footprint for multi-channel device

1.2 CD2XXX Device Family Compatibility

Features	CD2481	CD2401	CD2431	CD2231
Number of serial channels	4	4	4	2
Interrupt on-chip DMA mechanism	√ ¹	√	√	√
FIFO depth (per channel and per direction)	16	16	16	16
Data size (bits)	5-8	5-8	5-8	5-8
Async	Downloaded ²	√	√	√
HDLC/SDLC	Downloaded	√	√	√
X.21, Bisync	Downloaded	√	n/a	n/a
Async-HDLC, PPP (point-to-point protocol)	Downloaded	n/a	√	√
Programmable sync	Downloaded	n/a	n/a	n/a
Serial data rate (kbps)	230.4 ³	134.4 ⁴	134.4 ⁵	256/230.4 ⁶
Number of modem leads (per channel, including RxD and TxD)	10	10	10	10
On-chip timers	√	√	√	√
UNIX [®] character processing	Downloaded	√	√	√
Special character Tx and recognition	Downloaded	√	√	√
Package	100-pin MQFP	100-pin MQFP	100-pin MQFP	100-pin MQFP
Pin compatibility	CD24X1	CD24X1	CD24X1	CD24X1 ⁷

1.√ indicates identical operation and register setting.

2.Device microcode is not user-programmable; standard microcode is supplied by Intel.

3.Clock frequency of 60 MHz is required for 230.4 kbps. Applies to Revision B or later CD2481 devices.

4.Clock frequency of 35 MHz is required for 134.4 kbps (CD2401/CD2431); 256 kbps (sync)/230.4 kbps (async) (CD2231).

5.Clock frequency of 35 MHz is required for 134.4 kbps (CD2401/CD2431); 256 kbps (sync)/230.4 kbps (async) (CD2231).

6.Clock frequency of 35 MHz is required for 134.4 kbps (CD2401/CD2431); 256 kbps (sync)/230.4 kbps (async) (CD2231).

7.Compatible with all pins, except those supporting channels 2 and 3 on other family members. These pins are 'no connects' on the CD2231 or must be pulled up to V_{CC} through a 4.7-k Ω resistor (see the *CD2481 datasheet*).

2.0 Conventions

2.1 Abbreviations

Symbol	Units of measure
°C	degree Celsius
μF	microfarad
μs	microsecond (1,000 nanoseconds)
Hz	hertz (cycle per second)
Kbit	kilobit (1,024 bits)
kbits/second kbps	kilobit (1,000 bits) per second
Kbyte	kilobyte (1,024 bytes)
Kbytes/second	kilobyte (1,000 bytes) per second
kHz	kilohertz
kΩ	kilohm
Mbyte	megabyte (1,048,576 bytes)
MHz	megahertz (1,000 kilohertz)
mA	milliampere
ms	millisecond (1,000 microseconds)
ns	nanosecond
pV	picovolt
V	volt
W	watt

The use of 'tbd' indicates values that are 'to be determined', 'n/a' designates 'not available', and 'n/c' indicates a pin that is a 'no connect'.

2.2 Acronyms

Acronym	Definition
AC	alternating current
CMOS	complementary metal-oxide semiconductor
DC	direct current
DMA	direct-memory access
DRAM	dynamic random-access memory
FIFO	first in/first out
HDLC	high-level data link control
ISA	industry standard architecture
LSB	least-significant bit
MSB	most-significant bit
PPP	point-to-point protocol
MQFP	plastic quad-flat pack
RAM	random-access memory
R/W	read/write
SDLC	synchronous data link control
TTL	transistor-transistor logic

3.0 Pin Information

3.1 Pin Diagram — CD2481

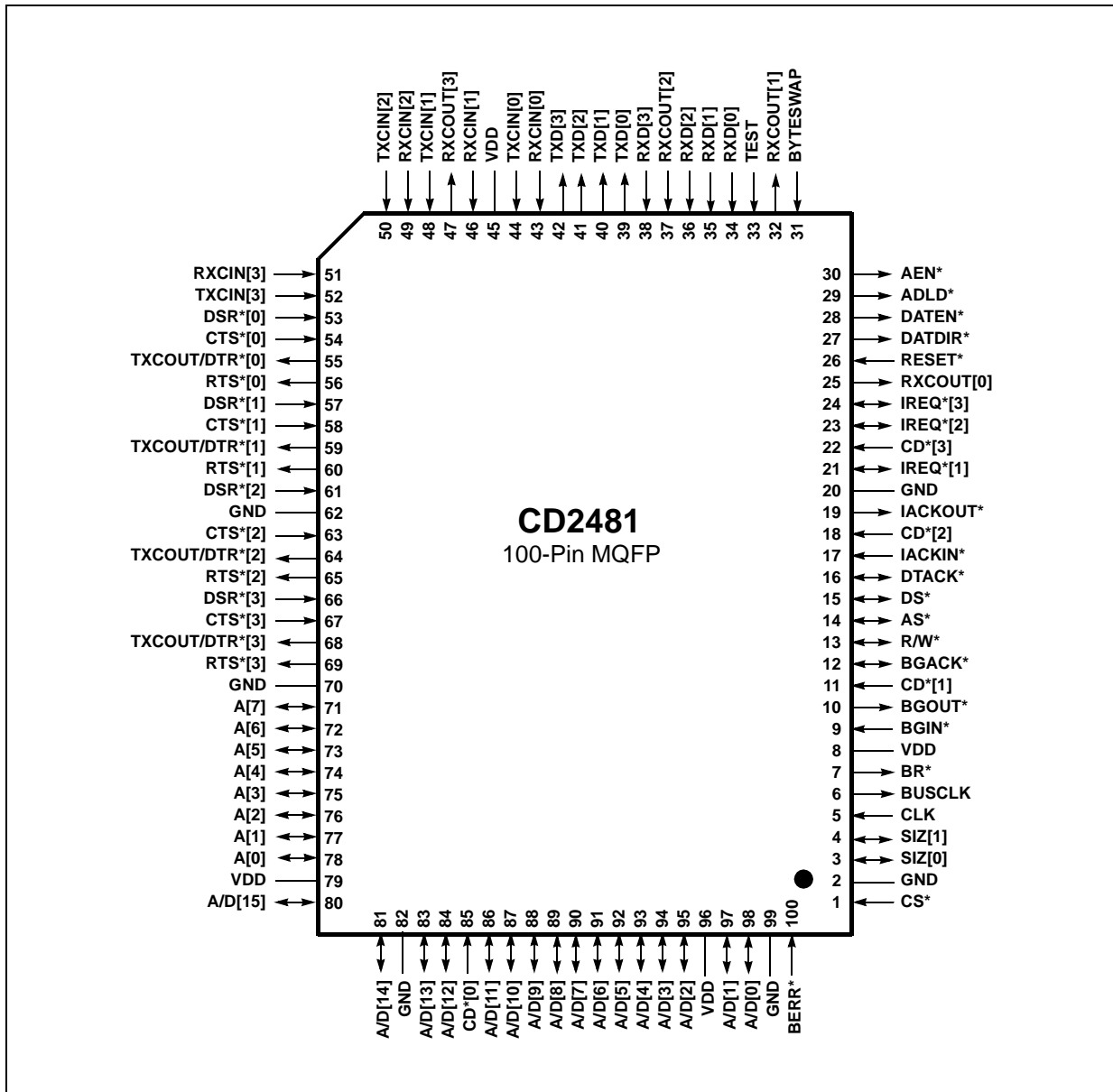

3.2 Pin Functions — CD2481

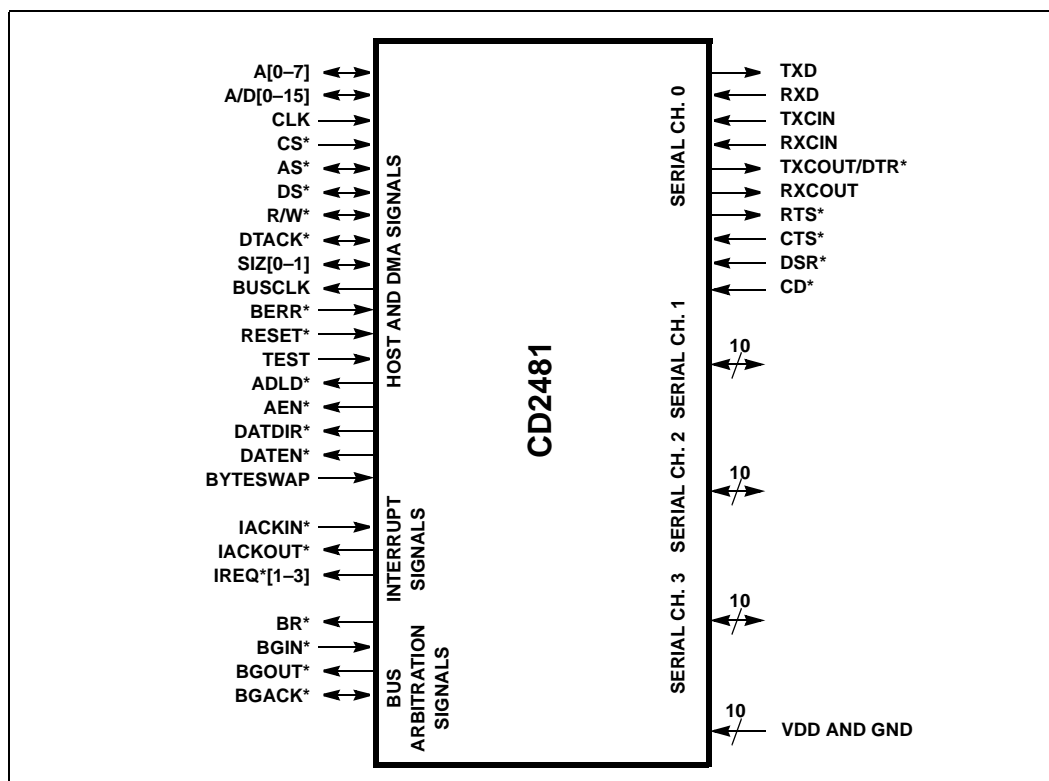

3.3 Pin Descriptions

The following conventions are used in the pin-description tables:

- (*) after a pin name indicates that the signal is active-low
- 'I' indicates the pin is input-only
- 'O' indicates the pin is output-only
- 'I/O' indicates the pin is bidirectional
- 'OD' indicates open-drain
- 'TS' indicates tristate
- '-' indicates ascending pin numbers
- ':' indicates descending pin numbers

Table 1. Pin Descriptions (Sheet 1 of 3)

Symbol	Type	Description																								
CS*	I	CHIP SELECT* : When low, the CD2481 registers may be read from or written to by the host processor.																								
AS*	I/O (TS)	ADDRESS STROBE* : When the CD2481 is a bus master, this pin is an output, which indicates that R/W*, A[0–7], and the externally latched A[8–31] are valid.																								
DS*	I/O (TS)	DATA STROBE* : When the CD2481 is not a bus master, this is an input used to strobe data into registers during write cycles and enable data onto the bus during read cycles. When the CD2481 is a bus master, DS* is an output used to control data transfer to and from system memory.																								
R/W*	I/O (TS)	READ/WRITE* : When the CD2481 is not a bus master, this pin is an input which determines if a read or write operation is required when the CS* and DS* signals are active. When the CD2481 is a bus master, R/W* is an output and indicates whether a read from or a write to system memory is being performed.																								
DTACK*	I/O (OD)	DATA TRANSFER ACKNOWLEDGE* : When the CD2481 is not a bus master, this is an output and indicates to the host when a read or write to the CD2481 is complete. When BR* is driven low by the CD2481, DTACK* is an input, which indicates that the system bus is no longer in use. When the CD2481 is a bus master, DTACK* is an input, which indicates when system memory read and write cycles are complete.																								
SIZ[0–1]	I/O (TS)	<p>SIZE [0–1]: When not the active bus master, these are inputs which determine the size of the operand being read or written by the host.</p> <table border="0"> <tr> <td>SIZ[1]</td> <td>SIZ[0]</td> <td></td> </tr> <tr> <td>0</td> <td>1</td> <td>- Byte *</td> </tr> <tr> <td>1</td> <td>0</td> <td>- 16 Bit</td> </tr> <tr> <td>0</td> <td>0</td> <td>- 32 Bit **</td> </tr> <tr> <td>1</td> <td>1</td> <td>- 3 Bytes**</td> </tr> </table> <p>When the CD2481 is a bus master, this is an output determining the size of the operand being transferred to or from system memory.</p> <table border="0"> <tr> <td>SIZ[1]</td> <td>SIZ[0]</td> <td></td> </tr> <tr> <td>0</td> <td>1</td> <td>- Byte *</td> </tr> <tr> <td>1</td> <td>0</td> <td>- 16 Bit</td> </tr> </table> <p>* See BYTESWAP description ** The CD2481 will drive DTACK* even though the device will not respond to such byte alignment.</p>	SIZ[1]	SIZ[0]		0	1	- Byte *	1	0	- 16 Bit	0	0	- 32 Bit **	1	1	- 3 Bytes**	SIZ[1]	SIZ[0]		0	1	- Byte *	1	0	- 16 Bit
SIZ[1]	SIZ[0]																									
0	1	- Byte *																								
1	0	- 16 Bit																								
0	0	- 32 Bit **																								
1	1	- 3 Bytes**																								
SIZ[1]	SIZ[0]																									
0	1	- Byte *																								
1	0	- 16 Bit																								
IACKIN*	I	INTERRUPT ACKNOWLEDGE IN* : This input qualified with DS* and A[0–6] acknowledges CD2481 interrupts.																								
IACKOUT*	O	INTERRUPT ACKNOWLEDGE OUT* : This output is driven low during interrupt acknowledge cycles for which no internal interrupt is valid.																								
IREQ*[1–3]	I/O (OD)	INTERRUPT REQUEST* [1–3] : These outputs signal that the CD2481 has a valid interrupt for modem-lead activity (IREQ*[1]), transmit activity (IREQ*[2]), or receive activity (IREQ*[3]).																								
BR*	O (OD)	BUS REQUEST* : This output is used to signal to the (open-drain) host processor or bus arbiter that bus mastership is required by the CD2481.																								
BGIN*	I	BUS GRANT IN* : This input indicates that the bus is available after the current bus master relinquishes the bus.																								
BGOUT*	O	BUS GRANT OUT* : This output is asserted when BGIN* is low and no internal bus request has been made. A daisy-chain scheme of bus arbitration can be formed by connecting BGOUT* to BGIN* of the next device in the chain. If a priority scheme is preferred, bus requests must be prioritized externally and bus grant routed to the BGIN* of the appropriate device.																								
BGACK*	I/O (OD)	BUS GRANT ACKNOWLEDGE* : As an input, this signal is used to determine if another alternate bus master is in control of the bus. As an output, it signals to other bus masters that this device is in control of the bus.																								

Table 1. Pin Descriptions (Sheet 2 of 3)

Symbol	Type	Description
BERR*	I	BUS ERROR* : If this input becomes active while the CD2481 is a bus master, the current bus cycle will be terminated, the bus relinquished, and an interrupt generated to indicate the error to the host processor.
A[0–7]	I/O (TS)	ADDRESS [0–7] : When the CD2481 is not a bus master, these pins are inputs used to determine which registers are being accessed, or which interrupt is being acknowledged. When ADLD* is low, A[0–7] output address bits 8–15 for external latching. When the CD2481 is a bus master, A[0–7] output the least-significant byte of the transfer address.
A/D[0–15]	I/O (TS)	ADDRESS/DATA [0–15] : When the CD2481 is not a bus master, these pins provide the 16-bit data bus for reading and writing to the CD2481 registers. When ADLD* is low, A/D[0–15] provide the upper address bits for external latching. When the CD2481 is a bus master, A/D[0–15] provide a multiplexed address/data bus for reading and writing to system memory.
ADLD*	O (TS)	ADDRESS LOAD* : This is a strobe used to externally latch the upper portion of the system address bus A[8–31]. While ADLD* is low, address bits 16–31 are available on A/D[0–15], and address bits 8–15 on A[0–7].
AEN*	O (TS)	ADDRESS ENABLE* : This output is used to output enable the external address bus drivers during CD2481 DMA cycles.
DATEN*	O (TS)	DATA ENABLE* : This output is active when either the CD2481 is a bus master, or the CS* and DS* pins are low. It is used to enable the external data bus buffers during host register read/write operations or during DMA operations. For operations on 32-bit buses, this signal needs to be gated with A[1] to select the correct half of the data bus.
DATDIR*	O (TS)	DATA DIRECTION* : This output is active when either the CD2481 is a bus master, or the CS* pin is low. It is used to control the external data buffers; when low, the buffers should be enabled in the CD2481 to system bus direction.
CLK	I	CLOCK : System clock.
BUSCLK	O	BUS CLOCK : This is the system clock divided by two, which is used internally to control certain bus operations. This pin is driven low during hardware reset.
RESET*	I	RESET* : This signal should stay valid for a minimum of 20 ns. The reset state of the CD2481 will be guaranteed at the rising edge of this signal. When RESET* is removed, the CD2481 also performs a software initialization of its registers.
TEST	I	TEST : In normal operation, this pin should be kept low. For board-level testing purposes, it provides a mechanism for forcing normal output pins to High-Impedance mode. When the TEST pin is high, the following pins will be in High-Impedance mode: BUSCLK, BGOUT*, IACKOUT*, RXCOUT[0–3], RTS*[0–3], DTR*[0–3], and TXD[0–3]. To ensure that all CD2481 outputs are high-impedance, either of the following two conditions must be met: the RESET* pin can be driven low, and the TEST pin driven high; or the CD2481 is kept in the bus idle state (not accessed for read/write operations nor DMA active), and the TEST pin is driven high.
RTS*[0–3]	O	REQUEST TO SEND* [0–3] : This output can be controlled automatically by the CD2481 to indicate that data is ready to be sent on the TXD pin.
TXCOUT/DTR*	O	TRANSMIT CLOCK OUT/DATA TERMINAL READY* [0–3] : This output can be controlled automatically by the CD2481 to indicate that a programmable threshold has been reached in the receive FIFO. It can also be programmed to output the transmit data clock. Following reset, this pin will be high and stays high in Clock mode until the transmit channel is enabled for the first time; after that it remains active independent of the state of the transmit enable. In all modes, the clock transitions every bit time, even during idle fill in Asynchronous mode. Data transitions are made on the negative going edge of TXCOUT.
RXCOUT[0–3]	O	RECEIVE CLOCK OUT [0–3] : This output provides a one-time bit rate clock for the receive data in all modes, except when an input (RXCIN) one-time receive clock is used. After reset, this pin will be low until the channel is receive enabled for the first time, after which it remains active, independent of the state of receive-enable. When in Asynchronous mode, the output only transitions while receiving data and not during inter-character fill. The receive data is sampled on the positive-going edge of this clock.

Table 1. Pin Descriptions (Sheet 3 of 3)

Symbol	Type	Description
CTS*[0–3]	I	CLEAR TO SEND* [0–3]: This input can be programmed to control the flow of transmit data, for out-of-band flow control applications.
TXCIN	I	TRANSMIT CLOCK: This pin inputs the transmit clock to the bit rate generator.
CD*	I	CARRIER DETECT*: This pin is always visible in the MSVR register. CD* is a general purpose modem input and can be used to cause modem group interrupts upon signal level transitions.
RXCIN	I	RECEIVE CLOCK: This pin inputs the receive clock to the bit rate generator.
DSR*	I	DATA SET READY*: This pin is always visible in the MSVR register. DSR* can be used to validate receive data as well as cause modem group interrupts upon signal level transitions.
TXD[0–3]	O	TRANSMIT DATA [0–3]: Serial data output for each channel.
RXD[0–3]	I	RECEIVE DATA [0–3]: Serial data input for each channel.
BYTESWAP	I	<p>BYTESWAP: This pin alters the byte ordering of data during certain 16-bit transfers. It also changes that half of the data bus on which byte transfers are made, to comply with Intel® or Motorola® processor systems. BYTESWAP does not alter the bus handshake signals. When the BYTESWAP pin is high, the byte on A/D[0–7] precedes that on A/D[8–15] in a string of transmit or receive bytes. When BYTESWAP is low, A/D[8–15] precedes A/D[0–7]. When the BYTESWAP pin is high, bytes are transferred on A/D[0–7] when A[0] is low, and on A/D[8–15] when A[0] is high. When BYTESWAP is low, bytes are transferred on A/D[8–15] when A[0] is low, and A/D[0–7] when A[0] is high. A different register map is used, depending on the state of this pin.</p> <p>Byteswap Byte Alignment</p> <ul style="list-style-type: none"> 0 Motorola byte alignment 1 Intel byte alignment

4.0 Register Summaries

Registers in the CD2481 are either Global or Per-Channel. The column ‘Address mode’ in the memory map on the following pages defines this attribute for each register. Only one set of Global registers exists, and is accessible by the host at any time. Two sets of Per-Channel registers exist, and the set accessible at any one time is determined by the currently active channel number. The channel number is selected by the host in normal (non-interrupt) processing by writing to the Channel Access register. The channel number in the Channel Access register remains in force until changed by the host. The channel number is provided automatically by the CD2481 during interrupt service routines and DMA transfers.

In the following list, some register locations appear twice. They have different names and functions for asynchronous and synchronous protocol operations. See [Chapter 9.0 on page 112](#) of this datasheet for detailed descriptions of all register functions.

Note also that not all registers are valid at any one time, depending on which functions are included in the microcode image which has been downloaded. Please refer to end-company dependent documentation for descriptions of the microcode images.

4.1 Memory Map

4.1.1 Global Registers

Name	Description	Addr. Mode ¹	INT ²	MOT ³	Size	Access	Page
GFRCR	Global Firmware Revision Code Register	G	82	81	B	R/W	112
CAR	Channel Access Register	G	EC	EE	B	R/W	112

The following notes are applicable for [Section 4.1.1](#) through [Section 4.1.7](#).

NOTES:

- Address mode G: Global register — one set is always accessible.
Address mode P: Per-Channel register — four sets, one per channel, accessible by CAR or interrupt context.
- INT = address for Intel[®]-style processor.
- MOT = address for Motorola[®]-style processor.

4.1.2 Option Registers

Name	Description	Addr. Mode ¹	INT ²	MOT ³	Size	Access	Page
CMR	Channel Mode Register	P	18	1B	B	R/W	113
COR1	Channel Option Register 1	P	13	10	B	R/W	114
COR2	Channel Option Register 2	P	14	17	B	R/W	116
COR3	Channel Option Register 3	P	15	16	B	R/W	123
COR4	Channel Option Register 4	P	16	15	B	R/W	130
COR5	Channel Option Register 5	P	17	14	B	R/W	131
COR6	Channel Option Register 6	P	1B	18	B	R/W	132
COR7	Channel Option Register 7	P	04	07	B	R/W	135
SCHR1	Special Character Register 1	P	1C	1F	B	R/W Async	136
SCHR2	Special Character Register 2	P	1D	1E	B	R/W Async	137
SCHR3	Special Character Register 3	P	1E	1D	B	R/W Async	138
SCHR4	Special Character Register 4	P	1F	1C	B	R/W Async	138
SCRI	Special Character Range low	P	20	23	B	R/W Async	138
SCRh	Special Character Range high	P	21	22	B	R/W Async	139
LNXT	LNext Character	P	2D	2E	B	R/W Async	139
RFAR1	Receive Frame Address Register 1	P	1C	1F	B	R/W Sync	139
RFAR2	Receive Frame Address Register 2	P	1D	1E	B	R/W Sync	140
RFAR3	Receive Frame Address Register 3	P	1E	1D	B	R/W Sync	140
RFAR4	Receive Frame Address Register 4	P	1F	1C	B	R/W Sync	140
CPSR	CRC Polynomial Select Register	P	D4	D6	B	R/W Sync	141
TSPMAP1	Transmit Special Mapped Character 1	P	1B	18	B	R/W PPP	141
TSPMAP2	Transmit Special Mapped Character 2	P	04	07	B	R/W PPP	141
TSPMAP3	Transmit Special Mapped Character 3	P	2D	2E	B	R/W PPP	142
TXACCM0	Transmit Async Control Character Map 0	P	1C	1F	B	R/W PPP	142
TXACCM1	Transmit Async Control Character Map 1	P	1D	1E	B	R/W PPP	142
TXACCM2	Transmit Async Control Character Map 2	P	1E	1D	B	R/W PPP	143
TXACCM3	Transmit Async Control Character Map 3	P	1F	1C	B	R/W PPP	143
RXACCM0	Receive Async Control Character Map 0	P	20	23	B	R/W PPP	143
RXACCM1	Receive Async Control Character Map 1	P	21	22	B	R/W PPP	144
RXACCM2	Receive Async Control Character Map 2	P	22	21	B	R/W PPP	144
RXACCM3	Receive Async Control Character Map 3	P	23	20	B	R/W PPP	144

4.1.3 Bit Rate and Clock Option Registers

Name	Description	Addr. Mode ¹	INT ²	MOT ³	Size	Access	Page
RBPR	Receive Baud Rate Period Register	P	C9	CB	B	R/W	145
RCOR	Receive Clock Option Register	P	CA	C8	B	R/W	145
TBPR	Transmit Baud Rate Period Register	P	C1	C3	B	R/W	146
TCOR	Transmit Clock Option Register	P	C2	C0	B	R/W	147

4.1.4 Channel Command and Status Registers

Name	Description	Addr. Mode ¹	INT ²	MOT ³	Size	Access	Page
CCR	Channel Command Register	P	10	13	B	R/W	148
STCR	Special Transmit Command Register	P	11	12	B	R/W	150
CSR	Channel Status Register	P	19	1A	B	R	153
MSVR-RTS MSVR-DTR	Modem Signal Value Registers	P	DC	DE	B	R/W	158
		P	DD	DF	B	R/W	158

4.1.5 Interrupt Registers

Name	Description	Addr. Mode ¹	INT ²	MOT ³	Size	Access	Page
LIVR	Local Interrupt Vector Register	P	0A	09	B	R/W	159
IER	Interrupt Enable Register	P	12	11	B	R/W	160
LICR	Local Interrupting Channel Register	P	25	26	B	R/W	162
STK	Stack Register	G	E0	E2	B	R	162

4.1.5.1 Receive Interrupt Registers

Name	Description	Addr. Mode ¹	INT ²	MOT ³	Size	Access	Page
RPILR	Receive Priority Interrupt Level Register	G	E3	E1	B	R/W	163
RIR	Receive Interrupt Register	G	EF	ED	B	R	164
RISR	Receive Interrupt Status Register	G	8A	88	W	R	165
RISRI	Receive Interrupt Status Register low	G	8A	89	B	R	165
RISRh	Receive Interrupt Status Register high	G	8B	88	B	R	171
RFOC	Receive FIFO Output Count	G	33	30	B	R	172
RDR	Receive Data Register	G	F8	F8	B	R	172
REOIR	Receive End of Interrupt Register	G	87	84	B	W	173

4.1.5.2 Transmit Interrupt Registers

Name	Description	Addr. Mode ¹	INT ²	MOT ³	Size	Access	Page
TPILR	Transmit Priority Interrupt Level Register	G	E2	E0	B	R/W	175
TIR	Transmit Interrupt Register	G	EE	EC	B	R	175
TISR	Transmit Interrupt Status Register	G	89	8A	B	R	176
TFTC	Transmit FIFO Transfer Count	G	83	80	B	R	177
TDR	Transmit Data Register	G	F8	F8	B	W	177
TEOIR	Transmit End of Interrupt Register	G	86	85	B	W	178

4.1.5.3 Modem Interrupt Registers

Name	Description	Addr. Mode ¹	INT ²	MOT ³	Size	Access	Page
MPILR	Modem Priority Interrupt Level Register	G	E1	E3	B	R/W	179
MIR	Modem Interrupt Register	G	ED	EF	B	R	179
MISR	Modem (/Timer) Interrupt Status Register	G	88	8B	B	R/W	180
MEOIR	Modem End of Interrupt Register	G	85	86	B	W	181

4.1.6 DMA Registers

Name	Description	Addr. Mode ¹	INT ²	MOT ³	Size	Access	Page
DMR	DMA Mode Register	G	F4	F6	B	W	182
BERCNT	Bus Error Retry Count	G	8D	8E	B	R/W	182
DMABSTS	DMA Buffer Status	P	1A	19	B	R	183

4.1.6.1 DMA Receive Registers

Name	Description	Addr. Mode ¹	INT ²	MOT ³	Size	Access	Page
ARBADRL	A Receive Buffer Address Lower	P	40	42	W	R/W	184
ARBADRU	A Receive Buffer Address Upper	P	42	40	W	R/W	184
BRBADRL	B Receive Buffer Address Lower	P	44	46	W	R/W	185
BRBADRU	B Receive Buffer Address Upper	P	46	44	W	R/W	185
ARBCNT	A Receive Buffer Byte Count	P	48	4A	W	R/W	186
BRBCNT	B Receive Buffer Byte Count	P	4A	48	W	R/W	186
ARBSTS	A Receive Buffer Status	P	4C	4F	B	R/W	186
BRBSTS	B Receive Buffer Status	P	4D	4E	B	R/W	187
RCBADRL	Receive Current Buffer Address Lower	P	3C	3E	W	R	188
RCBADRU	Receive Current Buffer Address Upper	P	3E	3C	W	R	188

4.1.6.2 DMA Transmit Registers

Name	Description	Addr. Mode ¹	INT ²	MOT ³	Size	Access	Page
ATBADRL	A Transmit Buffer Address Lower	P	50	52	W	R/W	189
ATBADRU	A Transmit Buffer Address Upper	P	52	50	W	R/W	189
BTBADRL	B Transmit Buffer Address Lower	P	54	56	W	R/W	190
BTBADRU	B Transmit Buffer Address Upper	P	56	54	W	R/W	190
ATBCNT	A Transmit Buffer Byte Count	P	58	5A	W	R/W	191
BTBCNT	B Transmit Buffer Byte Count	P	5A	58	W	R/W	191
ATBSTS	A Transmit Buffer Status	P	5C	5F	B	R/W	191
BTBSTS	B Transmit Buffer Status	P	5D	5E	B	R/W	192
TCBADRL	Transmit Current Buffer Address Lower	P	38	3A	W	R	196
TCBADRU	Transmit Current Buffer Address Upper	P	3A	38	W	R	196

Programmable Sync Mode

Idle	0	0	0	ChL3	ChL2	ChL1	ChL0
------	---	---	---	------	------	------	------

**Channel Option Register 2 (COR2)
HDLC Mode**

14 17 B R/W

0	FCSApd	0	CRCNinv	0	RtsAO	CtsAE	DsrAE
---	--------	---	---------	---	-------	-------	-------

Bisync Mode

LRC	BCC	EBCDIC	CRCNinv	SYN3	SYN2	SYN1	SYN0
-----	-----	--------	---------	------	------	------	------

Asynchronous Mode

IXM	TxIBE	ETC	0	RLM	RtsAO	CtsAE	DsrAE
-----	-------	-----	---	-----	-------	-------	-------

X.21 Mode

0	0	ETC	0	0	0	0	0
---	---	-----	---	---	---	---	---

Async-HDLC / PPP Mode

IXM	TxIBE	0	0	RLM	RtsAO	CtsAE	DsrAE
-----	-------	---	---	-----	-------	-------	-------

MNP4/SLIP Mode

0	0	0	0	RLM	RtsAO	CtsAE	DsrAE
---	---	---	---	-----	-------	-------	-------

Programmable Sync Mode

SYN2	Strip	0	0	0	RtsAO	CtsAE	DsrAE
------	-------	---	---	---	-------	-------	-------

**Channel Option Register 3 (COR3)
HDLC Mode**

15 16 B R/W

sndpad	Alt1	FCSPre	FCS	idle	npad2	npad1	npad0
--------	------	--------	-----	------	-------	-------	-------

Bisync Mode

sndpad	S55	FCSPre	FCS	DisCRCAI	npad2	npad1	npad0
--------	-----	--------	-----	----------	-------	-------	-------



Asynchronous Mode

EDCDE	RngDE	FCT	SCDE	Splstp	Stop2	Stop1	Stop0
-------	-------	-----	------	--------	-------	-------	-------

X.21 Mode

SglSYN	SSDE	StrpSyn	SCDE	0	0	0	0
--------	------	---------	------	---	---	---	---

Async-HDLC / PPP Mode

Stop2	FCSApd	RxChk	TxGen	npad3	npad2	npad1	npad0
-------	--------	-------	-------	-------	-------	-------	-------

SLIP Mode

Stop2	0	0	0	npad3	npad2	npad1	npad0
-------	---	---	---	-------	-------	-------	-------

MNP4 Mode

Stop2	FCSApd	RxChk	TxGen	npad3	npad2	pad1	pad0
-------	--------	-------	-------	-------	-------	------	------

Programmable Sync Mode

0	0	0	0	0	0	Append1	Append0
---	---	---	---	---	---	---------	---------

Channel Option Register 4 (COR4)

16 15 B R/W

DSRzd	CDzd	CTSzd	0	FIFO Threshold			
-------	------	-------	---	----------------	--	--	--

Channel Option Register 5 (COR5)

17 14 B R/W

DSRod	CDod	CTSod	In/Out	Rx Flow Control Threshold			
-------	------	-------	--------	---------------------------	--	--	--

**Channel Option Register 6 (COR6)
Asynchronous Mode**

1B 18 B R/W

IgnCR	ICRNL	INLCF	IgnBrk	NBrkInt	ParMrk	INPCK	ParInt
-------	-------	-------	--------	---------	--------	-------	--------

Bisync Mode

Special Frame Termination Character							
-------------------------------------	--	--	--	--	--	--	--

Transmit Special Mapped Character 2 (TSPMAP2)	04	07	B	R/W	PPP
Transmit Special Mapped Character 3 (TSPMAP3)	2D	2E	B	R/W	PPP

Transmit Async Control Character Maps (PPP only)

Transmit Async Control Character Map 0 (TXACCM0)	1C	1F	W/B	R/W	PPP
Transmit Async Control Character Map 1 (TXACCM1)	1D	1E	W/B	R/W	PPP
Transmit Async Control Character Map 2 (TXACCM2)	1E	1D	W/B	R/W	PPP
Transmit Async Control Character Map 3 (TXACCM3)	1F	1C	W/B	R/W	PPP

Receive Async Control Character Maps (PPP only)

Receive Async Control Character Map 0 (RXACCM0)	20	23	W/B	R/W	PPP
Receive Async Control Character Map 1 (RXACCM1)	21	22	W/B	R/W	PPP
Receive Async Control Character Map 2 (RXACCM2)	22	21	W/B	R/W	PPP
Receive Async Control Character Map 3 (RXACCM3)	23	20	W/B	R/W	PPP

4.2.3 Bit Rate and Clock Option Registers

Receive Baud Rate Period Register (RBPR)	C9	CB	B	R/W
--	----	----	---	-----

Receive Baud Rate Period (Divisor)

Receive Clock Option Register (RCOR)	CA	C8	B	R/W
--------------------------------------	----	----	---	-----

TLVal	0	DpllEn	Dpllmd1	Dpllmd0	ClkSel2	ClkSel1	ClkSel0
-------	---	--------	---------	---------	---------	---------	---------

Transmit Baud Rate Period Register (TBPR)	C1	C3	B	R/W
---	----	----	---	-----

Transmit Baud Rate Period (Divisor)

Transmit Clock Option Register (TCOR)	C2	C0	B	R/W
---------------------------------------	----	----	---	-----

ClkSel2	ClkSel1	ClkSel0	0	Ext-1X	0	LLM	0
---------	---------	---------	---	--------	---	-----	---

4.2.4 Channel Command and Status Registers

Channel Command Register (CCR)	10	13	B	R/W
--------------------------------	----	----	---	-----

Mode 1

0	ClrCh	InitCh	RstAll	EnTx	DisTx	EnRx	DisRx
---	-------	--------	--------	------	-------	------	-------

Mode 2

1	ClrT1	ClrT2	ClrRx	ClrTx	0	0	0
---	-------	-------	-------	-------	---	---	---

Special Transmit Command Register (STCR) **11 12 B R/W**
HDLC, X.21 and Bisync Modes

0	AbortTx	0	0	SndSpC	SSPC2	SSPC1	SSPC0
---	---------	---	---	--------	-------	-------	-------

Asynchronous Mode

0	AbortTx	AppdCmp	0	SndSpC	SSPC2	SSPC1	SSPC0
---	---------	---------	---	--------	-------	-------	-------

Async-HDLC/PPP Mode

0	AbortTx	0	0	SndSpC	frame	Xon	Xoff
---	---------	---	---	--------	-------	-----	------

SLIP/MNP4 Mode

0	AbortTx	0	0	SndSpC	frame	0	0
---	---------	---	---	--------	-------	---	---

Channel Status Register (CSR) **19 1A B R**
HDLC Mode

RxEn	RxFlag	RxFrame	RxMark	TxEn	TxFlag	TxFrame	TxMark
------	--------	---------	--------	------	--------	---------	--------

Bisync Mode

RxEn	RxITB	RxFrame	0	TxEn	TXITB	TxFrame	0
------	-------	---------	---	------	-------	---------	---

Asynchronous Mode

RxEn	RxFloff	RxFlon	0	TxEn	TxFloff	TxFlon	0
------	---------	--------	---	------	---------	--------	---

X.21 Mode

RxEn	0	RxSpC	0	TxEn	0	TxSpC	0
------	---	-------	---	------	---	-------	---

Async-HDLC/PPP Mode

RxEn	RxFloff	RxFrame	Ridle	TxEn	TxFloff	TxFrame	Tidle
------	---------	---------	-------	------	---------	---------	-------

SLIP/MNP4 Mode

RxEn	0	RxFrame	Ridle	TxEn	0	TxFrame	Tidle
------	---	---------	-------	------	---	---------	-------



Modem Signal Value Registers (MSVR) R/W
 Modem Signal Value Register (MSVR-RTS) DC DE B R/W
 Modem Signal Value Register (MSVR-DTR) DD DF B R/W

DSR	CD	CTS	DTRop	0	0	DTR	RTS
-----	----	-----	-------	---	---	-----	-----

4.2.5 Interrupt Registers

Local Interrupt Vector Register (LIVR) 0A 09 B R/W

X	X	X	X	X	X	IT1	IT0
---	---	---	---	---	---	-----	-----

Interrupt Enable Register (IER) 12 11 B R/W

Non_Async-HDLC/PPP Mode

Mdm	0	RET	0	RxD	TIMER	TxMpty	TxD
-----	---	-----	---	-----	-------	--------	-----

Async-HDLC/PPP Mode

Mdm	0	0	0	RxD	TIMER	TxMpty	TxD
-----	---	---	---	-----	-------	--------	-----

Local Interrupting Channel Register (LICR) 25 26 B R/W

X	X	X	X	C1	C0	X	X
---	---	---	---	----	----	---	---

Interrupt Stack Register (STK) E0 E2 B R

CLvl [1]	MLvl [1]	TLvl [1]	0	0	TLvl [0]	MLvl [0]	CLvl [0]
----------	----------	----------	---	---	----------	----------	----------

4.2.5.1 Receive Interrupt Registers

Receive Priority Interrupt Level Register (RPILR) E3 E1 B R/W

Receive Priority Match Value (only bits 6:0 are significant)
--

Receive Interrupt Register (RIR) EF ED B R

Ren	Ract	Reo	0	Rvct [1]	Rvct [0]	Rcn [1]	Rcn [0]
-----	------	-----	---	----------	----------	---------	---------

Receive Interrupt Status Register (RISR) **8A 88 W R**

Receive Interrupt Status Register low (RISRI) **8A 89 B R**
HDLC Mode

0	EOF	RxAbt	CRC	OE	ResInd	0	ClrDct
---	-----	-------	-----	----	--------	---	--------

Bisync Mode

0	EOF	RxAbt	CRC	OE	0	0	0
---	-----	-------	-----	----	---	---	---

X.21 Mode

LVal	SCdet2	SCdet1	SCdet0	OE	PE	0	LChg
------	--------	--------	--------	----	----	---	------

Asynchronous Mode

Timeout	SCdet2	SCdet1	SCdet0	OE	PE	FE	Break
---------	--------	--------	--------	----	----	----	-------

Async-HDLC / PPP / MNP4 Mode

0	EOF	RxAbt	CRC	OE	FE	0	Break
---	-----	-------	-----	----	----	---	-------

SLIP Mode

0	EOF	RxAbt	0	OE	FE	0	Break
---	-----	-------	---	----	----	---	-------

Receive Interrupt Status Register high (RISRh) **8B 88 B R**

Berr	EOF	EOB	0	BA/BB	0	0	0
------	-----	-----	---	-------	---	---	---

Receive FIFO Output Count (RFOC) **33 30 B R**

0	0	0	RxCt4	RxCt3	RxCt2	RxCt1	RxCt0
---	---	---	-------	-------	-------	-------	-------

Receive Data Register (RDR) **F8 F8 B R**

D7	D6	D5	D4	D3	D2	D1	D0
----	----	----	----	----	----	----	----

Receive End of Interrupt Register (REOIR) **87 84 B W**
Standard Asynchronous / HDLC / Bisync / X.21 Modes

TermBuff	DiscExc	SetTm2	SetTm1	NoTrans	Gap2	Gap1	Gap0
----------	---------	--------	--------	---------	------	------	------

Async-HDLC/PPP / SLIP / MNP4 Modes

TermBuff	DiscExc	SetTm2	SetTm1	NoTrans	0	0	0
----------	---------	--------	--------	---------	---	---	---

4.2.5.2 Transmit Interrupt Registers
Transmit Priority Interrupt Level Register (TPILR) E2 E0 B R/W

Transmit Priority Match Value (only bits 6:0 are significant)

Transmit Interrupt Register (TIR) EE EC B R

Ten	Tact	Teoi	0	Tvct [1]	Tvct [0]	Tcn [1]	Tcn [0]
-----	------	------	---	----------	----------	---------	---------

Transmit Interrupt Status Register (TISR) 89 8A B R

Berr	EOF	EOB	UE	BA/BB	0	TxEmpty	TxDat
------	-----	-----	----	-------	---	---------	-------

Transmit FIFO Transfer Count (TFTC) 83 80 B R

0	0	0	TxCt4	TxCt3	TxCt2	TxCt1	TxCt0
---	---	---	-------	-------	-------	-------	-------

Transmit Data Register (TDR) F8 F8 B W

D7	D6	D5	D4	D3	D2	D1	D0
----	----	----	----	----	----	----	----

Transmit End of Interrupt Register (TEOIR) 86 85 B W

TermBuff	EOF	SetTm2	SetTm1	Notrans	0	0	0
----------	-----	--------	--------	---------	---	---	---

4.2.5.3 Modem/Timer Interrupt Registers
Modem Priority Interrupt Level Register (MPILR) E1 E3 B R/W

Modem Priority Match Value (only bits 6:0 are significant)
--

Modem Interrupt Register (MIR) ED EF B R

Men	Mact	Meoi	0	Mvct [1]	Mvct [0]	Mcn [1]	Mcn [0]
-----	------	------	---	----------	----------	---------	---------

Modem (/Timer) Interrupt Status Register (MISR) 88 8B B R/W

DSRChg	CDChg	CTSChg	res	res	res	Timer2	Timer1
--------	-------	--------	-----	-----	-----	--------	--------

Modem End of Interrupt Register (MEOIR) **85** **86** **B** **W**

0	0	SetTm2	SetTm1	0	0	0	0
---	---	--------	--------	---	---	---	---

4.2.6 DMA Registers

DMA Mode Register (DMR) **F4** **F6** **F8** **W**

EnSync	0	0	0	ByteDMA	0	0	0
--------	---	---	---	---------	---	---	---

Bus Error Retry Count (BERCNT) **8D** **8E** **B** **R/W**

Binary Value							
--------------	--	--	--	--	--	--	--

DMA Buffer Status (DMABSTS) **1A** **19** **B** **R**

TDAIgr	RstApd	CrtBuf	Append	Ntbuf	Tbusy	Nrbuf	Rbusy
--------	--------	--------	--------	-------	-------	-------	-------

4.2.6.1 DMA Receive Registers

A Receive Buffer Address Lower (ARBADRL) **40** **42** **W** **R/W**

A Receive Buffer Address Upper (ARBADRU) **42** **40** **W** **R/W**

B Receive Buffer Address Lower (BRBADRL) **44** **46** **W** **R/W**

B Receive Buffer Address Upper (BRBADRU) **46** **44** **W** **R/W**

A Buffer Receive Byte Count (ARBCNT) **48** **4A** **W** **R/W**

B Buffer Receive Byte Count (BRBCNT) **4A** **48** **W** **R/W**

A Receive Buffer Status (ARBSTS) **4C** **4F** **B** **R/W**

B Receive Buffer Status (BRBSTS) **4D** **4E** **B** **R/W**

Berr	EOF	EOB	0	0	0	0	2481own
------	-----	-----	---	---	---	---	---------

Receive Current Buffer Address Lower (RCBADRL) **3C** **3E** **W** **R**

Receive Current Buffer Address Upper (RCBADRU) **3E** **3C** **W** **R**

4.2.6.2 DMA Transmit Registers

A Transmit Buffer Address Lower (ATBADRL) **50** **52** **W** **R/W**

A Transmit Buffer Address Upper (ATBADRU) **52** **50** **W** **R/W**

B Transmit Buffer Address Lower (BTBADRL)	54	56	W	R/W
B Transmit Buffer Address Upper (BTBADRU)	56	54	W	R/W
A Buffer Transmit Byte Count (ATBCNT)	58	5A	W	R/W
B Buffer Transmit Byte Count (BTBCNT)	5A	58	W	R/W
A Transmit Buffer Status (ATBSTS)	5C	5F	B	R/W
B Transmit Buffer Status (BTBSTS)	5D	5E	B	R/W
Async-HDLC / PPP Mode				

Berr	EOF	EOB	0	0	map32	INTR	2481own
------	-----	-----	---	---	-------	------	---------

SLIP / MNP4 Mode

Berr	EOF	EOB	0	0	0	INTR	2481own
------	-----	-----	---	---	---	------	---------

Asynchronous

Berr	EOF	EOB	UE	Append	0	INTR	2481own
------	-----	-----	----	--------	---	------	---------

X.21 / HDLC Modes

Berr	EOF	EOB	UE	0	0	INTR	2481own
------	-----	-----	----	---	---	------	---------

Bisync Mode

Berr	EOF	EOB	UE	0	DisCRC	INTR	2481own
------	-----	-----	----	---	--------	------	---------

Transmit Current Buffer Address Lower (TCBADRL)	38	3A	W	R
Transmit Current Buffer Address Upper (TCBADRU)	3A	38	W	R

4.2.7 Timer Registers

Timer Period Register (TPR)	D8	DA	B	R/W
------------------------------------	-----------	-----------	----------	------------

Binary Value

Receive Time-Out Period Register (RTPR)	26	24	W	R/W Async
--	-----------	-----------	----------	------------------

Receive Time-Out Period Register low (RTPRI)	26	25	B	R/W Async
---	-----------	-----------	----------	------------------

Binary Value, bits 7:0



Receive Time-Out Period Register high (RTPRh) 27 24 B R/W Async

Binary Value, bits 15:8

General Timer 1 (GT1) 28 2A W R Sync

General Timer 1 low (GT1l) 28 2B B R Sync

Binary Value, bits 7:0

General Timer 1 high (GT1h) 29 2A B R Sync

Binary Value, bits 15:8

General Timer 2 (GT2) 2A 29 B R Sync

Binary Value

Transmit Timer Register (TTR) 2A 29 B R Async

Binary Value

5.0 Functional Description

5.1 Host Interface

The CD2481 is a synchronous device with an asynchronous bus interface. A stable input clock is required on the CLK pin — nominally 60 MHz. CLK is divided by two internally, and the resulting clock controls internal device timing and is output on the BUSCLK pin. The baud-rate generators and timers are also related to CLK. The “AC Electrical Characteristics (Revision B at 35 MHz)” section in [Chapter 10.0](#) shows that many input signal setup and output signal transitions are related to the edges of the CLK and BUSCLK signals. It is possible, however, to use the CD2481 in a purely asynchronous bus environment.

The CD2481 can act as either bus master, during DMA transfers, or as a bus slave device during normal host read and write transfers. Both byte and word transfers are supported in each of the Bus Slave and DMA Bus Master modes. [Figure 2](#) and [Figure 3](#) show the signals involved in these transfers.

5.1.1 Host Read and Write Cycles

The host read and write cycles begin with the activation of the CS* (chip select) and DS* (data strobe) signals. The DATADIR* (data direction) and DATEN* (data enable) signals are used to control external data buffers. The falling edge of the DTACK* (data transfer acknowledge) signal indicates that the transfer is complete. DTACK* is released when DS* is deasserted. CS* should also be deasserted at that time. The AS* (address strobe) is not used during slave cycles; it is an output during DMA transfers.

Note that the following open-drain and tristate outputs should have pull-up resistors attached: AEN*, AS*, DATADIR*, DATEN*, and DTACK*.



Figure 2. Host Read Cycle

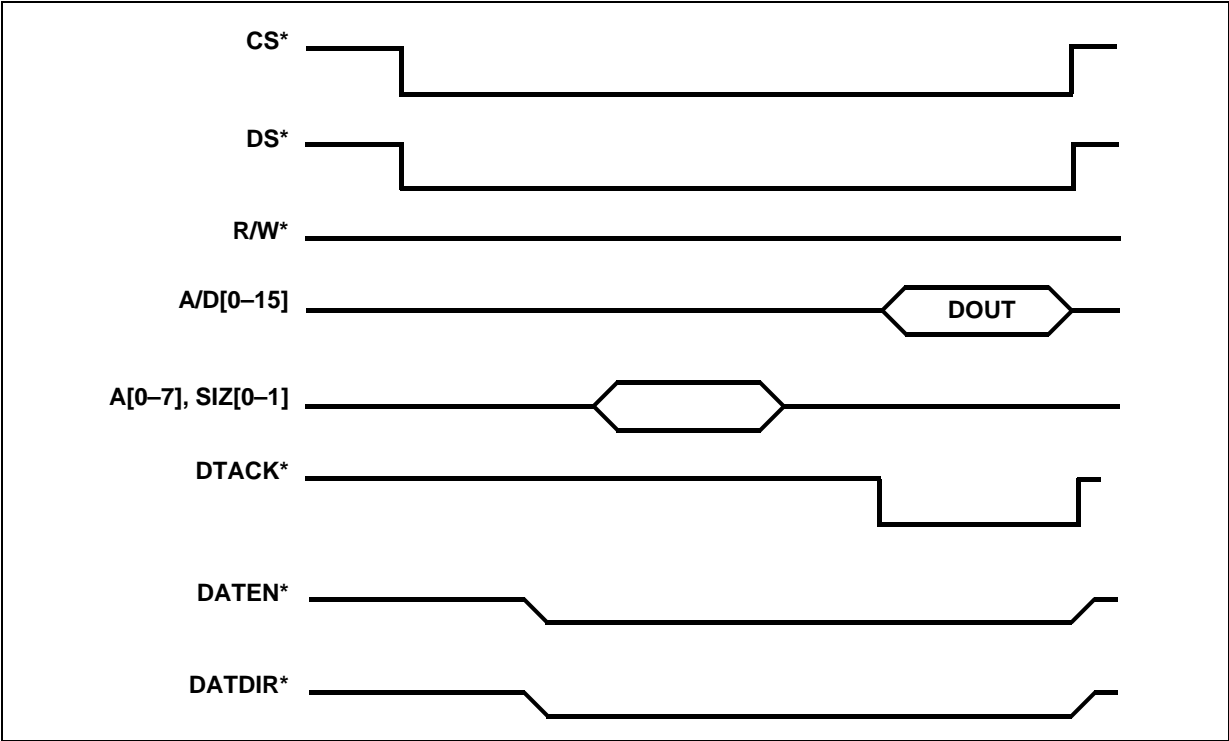
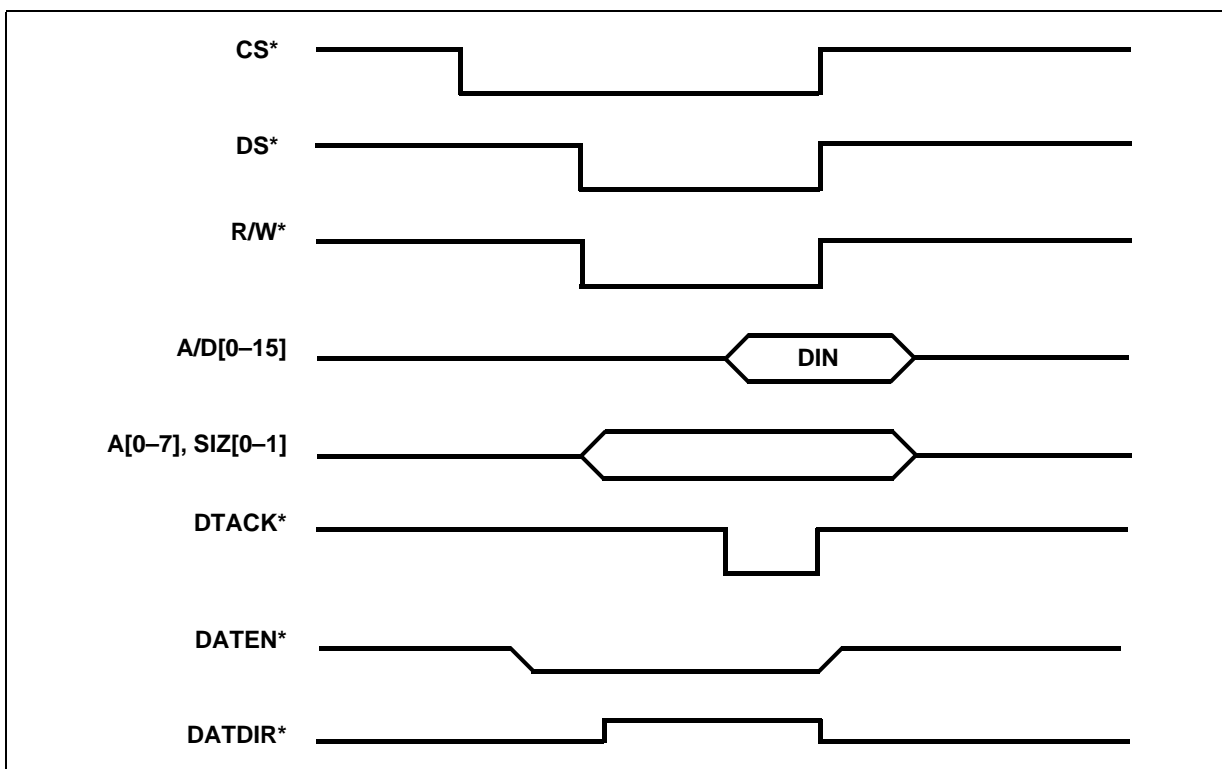

Figure 3. Host Write Cycle



5.1.2 Byte and Word Transfers

Data can be moved to and from the CD2481 in either byte or word transfers. Many registers are 16-bits wide and, while these can be accessed as individual bytes, some, such as timers, should be accessed only with word transfers. To accommodate various families of host processors, the BYTESWAP input pin is set to indicate the system byte-ordering scheme. The size pins (SIZ[1,0]) are used to indicate whether the transfer is 1 or 2 bytes wide.

In systems where the even addresses represent the high-order byte, the BYTESWAP input pin should be tied low, and byte transfers occur on the A/D[15:8] pins for even addresses and on the A/D[7:0] pins for odd addresses. In systems where the high-order byte is on the odd address, the situation is reversed, and BYTESWAP should be tied high. Byte transfers to even addresses occur on the A/D[7:0] pins, and to odd addresses on the A/D[15:8] pins.

5.2 Interrupts

The CD2481 uses interrupt requests to alert the host that certain events requiring its attention have occurred. Interrupt operations on the CD2481 are tightly coupled with several registers described below. The concept of context affects the accessibility of these and other registers.

5.2.1 Contexts and Channels

The registers in the CD2481 are grouped into Global, Virtual, and four sets of Per-Channel registers. The CD2481 is normally in the background context, where the CAR (Channel Access Register) selects the channel number for Per-Channel registers. The interrupt context begins with the interrupt acknowledge bus cycle, and ends with a write access to the appropriate End of Interrupt register (EOIR). During the interrupt context, only the per-channel registers for the channel number being serviced are available; the CAR has no effect. Most Global registers are available at all times, but some are shared by the four channels, such as the FIFO registers. These are called Virtual registers, and must be accessed *only* during an interrupt context.

Interrupt contexts can be nested so that a higher-priority interrupt service can preempt a lower priority interrupt already in progress. The CD2481 pushes the current interrupt context onto the stack, visible in the STK (Stack register), and enters the context for the newly acknowledged interrupt. Any register accesses are in the new interrupt context until the host does a write to the appropriate EOIR for the top-level context. The CD2481 pops the top-level context off the stack and returns to the previous interrupt context.

5.2.2 Interrupt Registers

The IER (Interrupt Enable register) and the LIVR (Local Interrupt Vector register) are Per-Channel registers. IER contains bits used to enable or disable the various interrupt sources within the CD2481. The LIVR value is output on the data bus during the interrupt acknowledge cycle. There are sets of three Global registers that correspond to the three types of interrupts: Receive, Transmit, and Modem. The Priority Interrupt Level registers — RPILR, TPILR, and MPILR — are programmed to contain the value that will be present on the address bus during the interrupt acknowledge bus cycle for each type of interrupt. The Interrupt Status registers — RISR, TISR, or MISR — are examined during the interrupt service routine to determine the cause of each type of interrupt. The TDR (Transmit Data) and RDR (Receive Data) registers provide access to the FIFO buffers for each channel. They *must not* be accessed outside of the appropriate interrupt context. A write operation to the End of Interrupt registers — REOIR, TEOIR, or MEOIR — must be the last access to the CD2481 at the end of this handler routine to return it to its non-interrupt context.

Figure 4. Interrupt Acknowledge Cycle

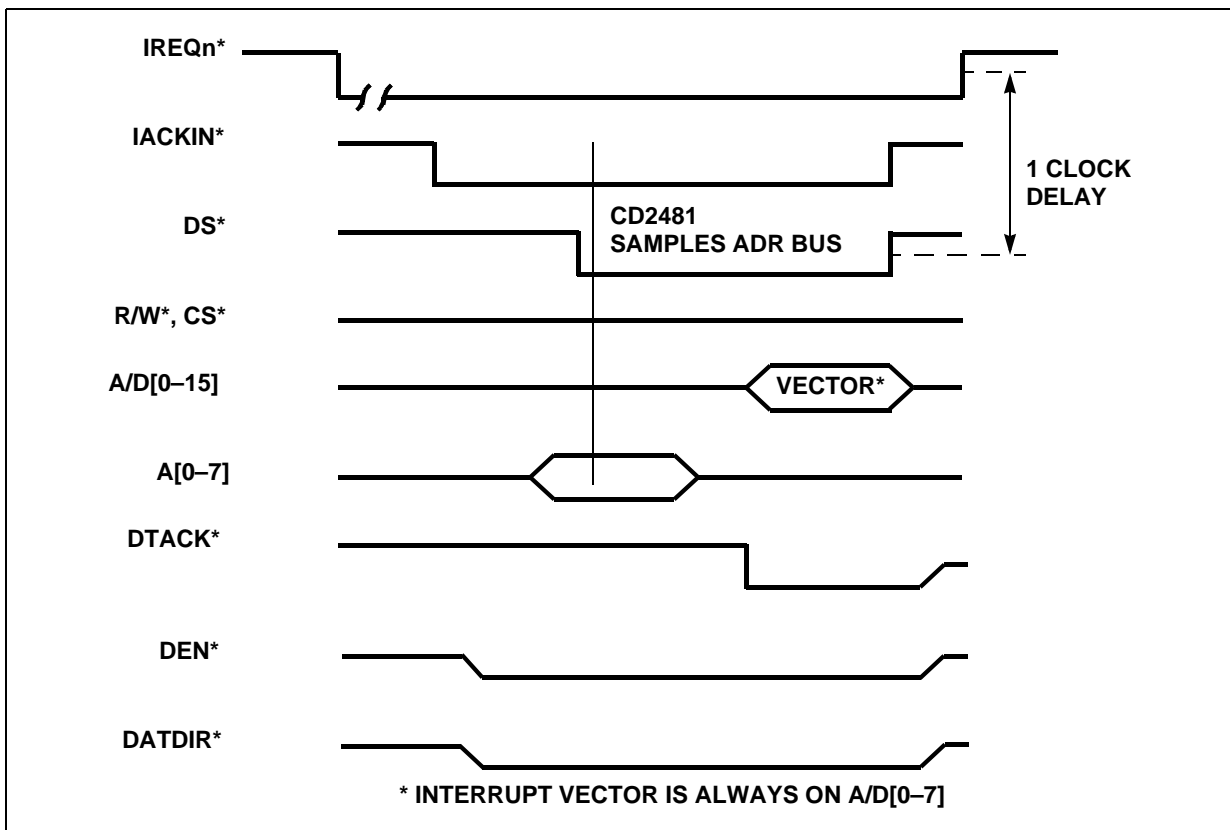

5.2.3 Groups and Types

There are two general reasons for the CD2481 to request service from the host processor — data transfer and exceptional conditions. Furthermore, interrupts are grouped into three categories, each with an associated Interrupt Request signal — IREQ1*, IREQ2*, and IREQ3*.

- Group 1 — Modem signal change/timer events
- Group 2 — Transmit interrupts
- Group 3 — Receive interrupts

Group 1 is only used for exceptions. Groups 2 and 3 include both data transfer and exceptions. Table 2 shows the possible causes of transmit and receive interrupt service requests. The cause of an interrupt request is encoded into the two least-significant bits of the vector presented on the data bus during the interrupt acknowledge cycle. The most-significant six bits of the vector come from the LIVR and are user defined:

Interrupt Vector LSBs

- | | |
|----|------------------------------------|
| 00 | Receive exception |
| 01 | Modem signal change or timer event |
| 10 | Transmit data or exception |
| 11 | Receive Good Data |

Table 2. Transmit and Receive Interrupt Service Requests

Interrupt Cause	Async	HDLC	Bisync	X.21	PPP	SLIP	MNP4 [®]
Receive Good Data ^{™ 1}	•	•	•	•	•	•	•
Break detect	•				•	•	•
Framing error	•				•	•	•
Parity error	•		•	•			
Receive time-out, no data	•				•	•	•
Special character match	•		•	•			
Transmitter empty	•	•	•	•	•	•	•
Tx FIFO threshold ^a		•	•	•	•	•	•
Receive overrun	•	•	•	•	•	•	•
Clear detect		•					
CRC error		•	•		•		•
Residual bit count		•					
Receive abort		•	•		•	•	•
End of frame		•	•	•	•	•	•
Transmit underrun		•					
Bus error ²	•	•	•	•	•	•	•
End of buffer ^b	•	•	•	•	•	•	•

1.Non-DMA mode

2.DMA mode only

5.2.4 Hardware Signals and IACK Cycles

The IACK (interrupt acknowledge) bus cycle begins with the IACKIN* (Interrupt Acknowledge In) and DS* asserted, and a value matching the appropriate PILR contents on the least-significant seven address bus bits, A[6:0]. If the IACK cycle is valid (that is, the A[6:0] and PILR values match), the corresponding vector from the interrupting channels LIVR is driven onto the data bus and DTACK* asserted. DTACK* is released after DS* is removed.

Figure 4 shows the interrupt acknowledge cycle timing. It is similar to the basic host read cycle except that IACKIN* is active, and CS* is inactive.

The three IREQn* pins are open-drain outputs requiring external pull-up resistors, nominally 4.7 kΩ. The IACKOUT* (Interrupt Acknowledge Out) is used to form a daisy-chain in systems with more than one CD2481.

5.2.4.1 Programming the PILR Registers

The three PILRs must be programmed with values that correspond to the least-significant seven address bits that will be present on A[6:0] during the interrupt acknowledge bus cycle. Some CPUs output the priority level of the interrupt that is being acknowledged on the bus during the IACK cycle. In these systems the three PILR values are unique. In other systems that do not use this scheme, the PILR values can be the same or different depending on the specific design. When all of

the PILR registers contain the same value and multiple IREQn* lines are asserted, the CD2481 imposes the following automatic priority scheme to determine which interrupt request will be acknowledged:

Highest priority: Receive Interrupt register

Transmit Interrupt register

Lowest priority: Modem Interrupt register

5.2.4.2 Systems with Interrupt Controllers

Some systems use an interrupt controller that supplies its own vector during the interrupt acknowledge cycle. The CD2481 needs an IACK cycle in response to its interrupt request to function properly. These systems can decode three distinct locations for the CD2481 to produce an IACKIN* instead of CS*. The PILR registers should be programmed with the least significant seven bits of the addresses of these three locations.

Alternatively, a single location can be decoded and the three PILRs given identical values as described above. In either case, the host should read one of these locations before the first access to the device in an interrupt service routine. The CD2481 enters its interrupt context for the proper type and channel, and the data returned is the device interrupt vector from the LIVR.

5.2.4.3 Multi-CD2481 Systems

Multiple CD2481s can be chained together for systems requiring more than four channels. Each group of interrupt request lines — IREQn* — can be connected in a parallel, wired-OR fashion. The system Interrupt Acknowledge signal is connected to the IACKIN* (Interrupt Acknowledge In) pin of the first device, and its IACKOUT* (Interrupt Acknowledge Out) is then connected to the IACKIN* of the next device, and so on, forming a chain of CD2481s.

5.2.4.4 Keep and Pass Logic

The acceptance of an interrupt acknowledge cycle by the CD2481 depends on whether the part is requesting service and whether the least-significant seven address bits match the contents of the appropriate PILR register. The following rules apply to the keep and pass logic:

1. If the CD2481 does not have an interrupt asserted, the interrupt acknowledge is passed out on IACKOUT*.
2. If the CD2481 is asserting one or more of its interrupts, but the interrupt priority level driven on the address bus by the host does not match the contents of the appropriate PILR register, the interrupt acknowledge is also passed out on IACKOUT*.
3. If the CD2481 is asserting an interrupt, and the interrupt priority level on the address bus matches the PILR register for that interrupt type, the interrupt acknowledge is accepted by the CD2481, and the vector from the LIVR is driven onto the data bus.

5.2.4.5 Fair Share Scheme

When multiple CD2481s are chained, the Fair Share logic in these devices guarantees that the interrupts from all CD2481s in the system are presented to the host with equal urgency. There is no positional hierarchy in the interrupt scheme, that is, the CD2481 that is farthest from the host has

an equal chance of getting its interrupts through as the CD2481 that is nearest to the top of the interrupt chain. The Fair Share scheme is totally transparent to the user, and no enabling or disabling is required.

When an interrupt request line is asserted, the Fair bit for that type of interrupt on the asserting device is cleared. The Fair bit remains cleared until the interrupt line returns to a high state. The CD2481 does not assert a new interrupt of that type while the corresponding Fair bit is cleared. Therefore, when multiple CD2481s assert interrupts together, each one is serviced in turn, before they can reassert the same interrupt type.

The IREQn* interrupt request lines are open-drain outputs that can be tied together in groups of the same type, creating a Fair Share scheme for each group of interrupts. Alternatively, all three groups can be tied to a common request and using the CD2481 internal automatic priority scheme (see [Section 5.2.4.1](#)).

5.3 FIFO and Timer Operations

Each channel in the CD2481 has a 16-byte receive FIFO and a 16-byte transmit FIFO. The FIFOs are accessible through the RDR (Receive Data register) and TDR (Transmit Data register) registers. These Virtual registers are shared among the four channels; therefore, they can not be accessed outside of an interrupt context.

Each channel's threshold level is common for both FIFOs. It is set by COR4 (Channel Option Register 4), with a maximum threshold value of 12. The FIFO threshold is meaningful in both DMA and non-DMA modes. In DMA mode, the FIFO threshold determines when transfer bursts will occur. In non-DMA mode, the threshold level determines when transfer interrupts are asserted.

5.3.1 Receive FIFO Operation

In the Asynchronous mode, a Good Data™ interrupt is initiated when the number of characters in the FIFO is greater than the FIFO threshold. Note that receive time-out and receive data exception conditions also cause an interrupt from the device.

In the Synchronous mode, an interrupt request for data transfer is initiated when either the number of characters is greater than the FIFO threshold or an end of frame has been received.

5.3.2 Transmit FIFO Operation

The TxDat and TxEmpty bits in the IER control the generation of transmit FIFO interrupts. The CD2481 initiates an interrupt request for more data when the number of empty bytes in the FIFO is greater than the threshold set by COR4. During synchronous operation, when the last byte of the frame is transferred to the FIFO, the CD2481 stops asserting transmit interrupts until the frame is sent, including the FCS and closing flag, if any.

5.3.3 Timers

The global TPR (Timer Period register) provides a timer prescale 'tick' as a clock source for the various timers in the device. The TPR counter is clocked by the system clock (CLK) divided by 2048. To maintain timer accuracy, the TPR register should not be programmed with a value not less than 16 (10 hex) — a 'tick' of about 1 millisecond when CLK is 33 MHz.

Each channel has two timers, one 16-bit general timer 1 (GT1) and one 8-bit general timer 2 (GT2). Their operation and programming are different in synchronous and asynchronous protocols.

5.3.4 Timers in Synchronous Protocols

In synchronous protocols, the timers have no special significance for the CD2481; they are available to support the protocols. They are started by host commands or by interrupts generated by the CD2481. General timers 1 and 2 can be started in either of two ways:

1. By loading a new value to GT1 or GT2 when the timer is not running.
2. By setting the SetTm1 or SetTm2 bits in the End of Interrupt register when terminating an interrupt service routine. In this case, the value should be written to the appropriate Interrupt Status register (RISR, TISR, MISR).

These timers can be disabled by a command through the CCR (Channel Command register).

5.3.5 Timers in Asynchronous Protocols

The receive timer is restarted from the value programmed in RTPR every time a character is received and loaded into the FIFO, or data is read by the host. For example, receive FIFO threshold is set to eight, and six characters are stored in the receive FIFO. If no more characters are received and the receiver timer times-out, a receive interrupt is asserted (in DMA mode, DMA transfer occurs). The host is expected to retrieve all six characters from the receive FIFO. Assuming the host is still enabling this feature (that is, RET bit from the IER register bit 5 is still set), and if there is no character being received and receiver timer times-out, a receive exception time-out interrupt (a group 3 interrupt) is asserted. The timer can be disabled if the value in RTPR is set to '0' or the RET bit is cleared.

5.3.6 Transmit Timer

The TTR (Transmit Timer register) is used only if the embedded transmit command is enabled in the COR2 register. The delay transmit command specifies the delay period loaded in the TTR; no further transmit operations are performed until this timer reaches zero. The current state of the line is held at either '0' for send break or '1' for inter-character fill.

5.4 DMA Operation

The CD2481 uses a simple, but powerful, double-buffering method that is readily compatible with higher-level buffer control procedures, such as circular queues, link lists, and buffer pools. Each transmitter and each receiver is assigned an 'A' and a 'B' buffer. When transmitting, the host processor alternately fills the A and B buffers and commands the CD2481 to transmit the buffers one at a time. When receiving, the CD2481 fills the A and B buffers and informs the host processor when each is ready.

A simple Ownership Status bit is used for each buffer; this ensures that there are no deadlocks between the host and the CD2481 regarding the use of a particular buffer.

By using the simple and flexible DMA management of the CD2481, the user host processor is concerned with transmit/receive data on a block-by-block basis. The user does not need to be concerned with character-by-character transfers, or even filling and emptying the FIFOs. The DMA control is user-selectable per-channel and operates independently of one another.

The CD2481 can perform DMA operations in any of the supported line protocols. A special Append mode feature can reduce host CPU overhead for asynchronous data streams. DMA operations are channel- and direction-specific. In each channel, either the transmitter and the receiver, or both, can be independently programmed for DMA mode by the CMR (Channel Mode register).

When the CD2481 acquires the bus for a DMA transfer, only data for one channel and in one direction is transferred; then, bus ownership is relinquished. A maximum of 16 bytes — the depth of the transmit and receive FIFOs — are transferred during any ownership cycle.

Whenever possible, DMA cycles are 16 bits wide, and buffers have the proper byte alignment. Unaligned buffers are sent using only 8-bit-wide transfers. If the buffer begins on an even address and contains an odd number of bytes, the CD2481 uses 16-bit transfers for all the words in the buffer except the last transfer, which is 8 bits.

If one buffer in a chain ends on an odd address, the next buffer in the chain should also start on an odd address to keep the proper alignment and the most efficient bus usage. In this case, only the last transfer of the first buffer and the first transfer of the next buffer is 8 bits wide; all others are 16 bits.

The CD2481 can be forced to perform only byte-wide DMA operations by setting the byte DMA bit in the DMR (DMA Mode register).

5.4.1 Bus Acquisition Cycle

1. CD2481 asserts BR* and waits for BGIN*.
2. When BGIN* is detected, the CD2481 can access the bus after the current bus owner relinquishes control of the bus.
3. If BGACK* is high when BGIN* goes low, then the bus is free to access. In this case, go to step 5.
4. If BGACK* is low when BGIN* goes low, then the bus is in use. The CD2481 waits for BGACK* to go high.
5. Once the CD2481 senses that BGACK* is high, it waits for the current bus cycle to terminate (DS* and DTACK* high) and then asserts BGACK* by driving it low. At that time, the CD2481 'owns' the bus. After driving BGACK* low, the CD2481 drives BR* high.

Figure 5 on page 47 is an example in which the CD2481 was required to wait to access the bus.

5.4.2 DMA Data Transfer

After the CD2481 acquires the bus, it pulses ADLD* once. This loads the upper 24 address bits to the external 24-bit latch. This happens only once per DMA grant cycle. The AD[0–15] bits are remapped to Memory Address bits MA[16–31], and A[0–7] are mapped to MA[8–15]. If during DMA, the upper 24 bits need to change, the CD2481 relinquishes the bus and then reacquires the bus.

During each DMA read and write cycle, the least-significant eight memory address bits, MA[0–7] come from A[0–7].

Figure 6 on page 47 is an example of one DMA access after bus is acquired.

Figure 5. Bus Acquisition Cycle

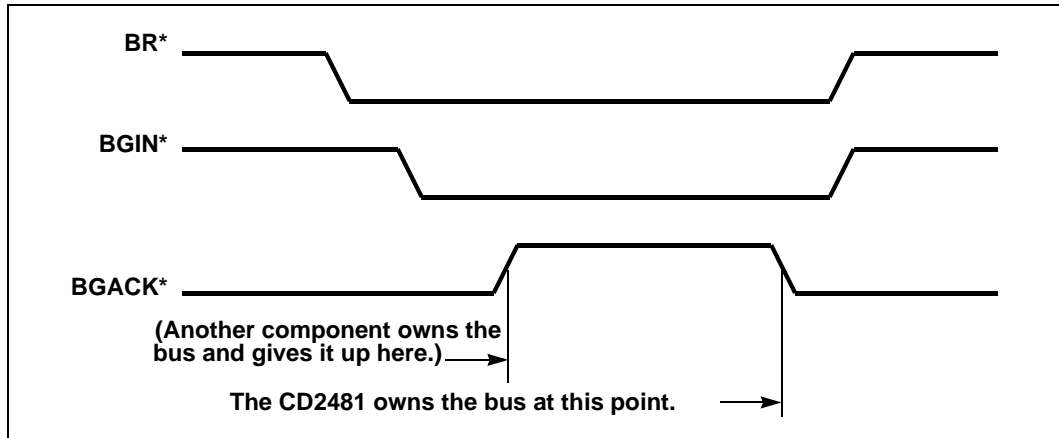
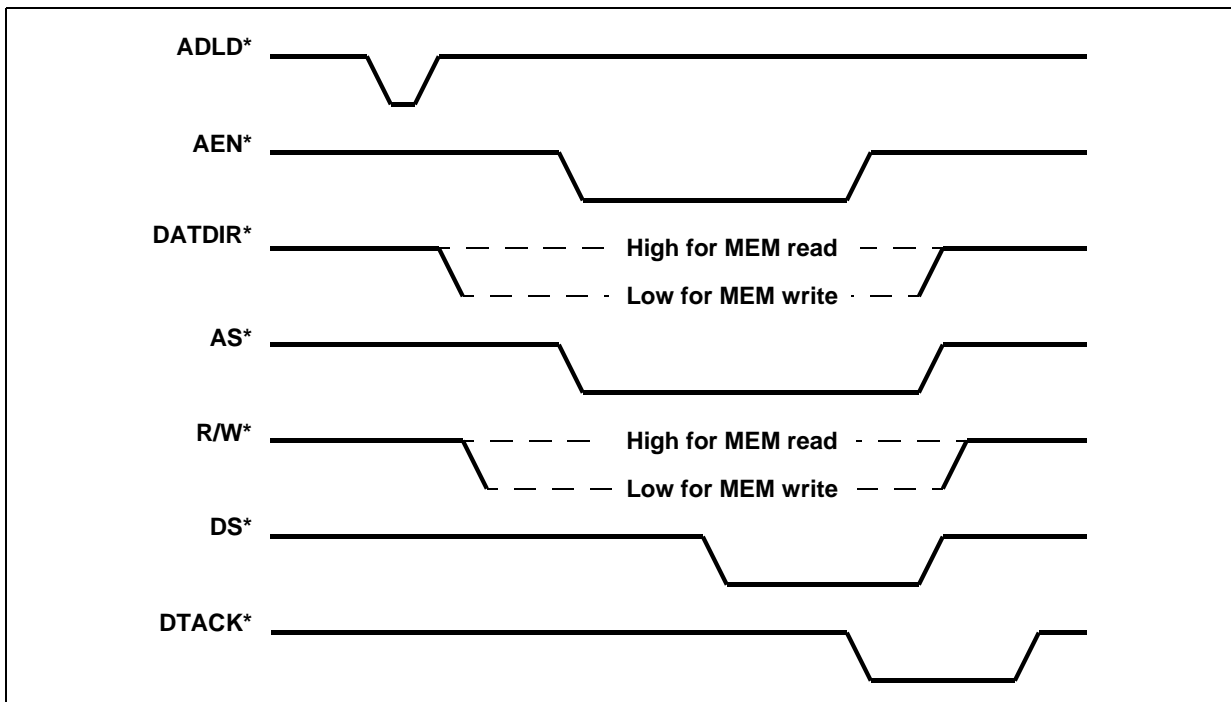

Figure 6. Data Transfer Timing



5.4.3 Bus Error Handling

When a bus error is detected during a DMA sequence, the CD2481 terminates the current bus cycle and relinquishes the bus. Any data transfer in the bus ownership cycle is ignored, and the original conditions are restored. A subsequent retry attempt would start again from these original conditions.

If there is a non-zero value in the BERCNT (Bus Error Retry Count register), the register is decremented, and the failed transfer is retried automatically. If the BERCNT is zero, a bus error interrupt is generated, and DMA transfers are suspended on the failing buffer until the interrupt is serviced.

5.4.4 A and B Buffers and Chaining

The buffer management of the CD2481 uses a dual-buffer scheme. There is an A and B buffer pair for each transmitter and each receiver. Each buffer is controlled by an Ownership Status bit, called 2481OWN. When 2481OWN is set to '1', the CD2481 owns the buffer. When 2481OWN is set to '0', the host owns the buffer. A simple rule prevents confusion in the buffer management: neither the CD2481 nor the host seizes buffer ownership. Each always relinquishes ownership to the other.

The host gives ownership of a receive buffer to the CD2481 when the receive buffer is ready. The CD2481 is then free to write received data into the buffer. The CD2481 returns ownership of the receive buffer after the receive data is in the buffer. The host gives ownership of a transmit buffer to the CD2481 when the transmit buffer is ready to transmit. The CD2481 then transmits the contents of the buffer. When this is complete, the CD2481 returns ownership back to the host.

The CD2481 keeps track of which buffer (A or B) is to be used next in the status bits — Ntbuf for transmit and Nrbuf for receive. The relationship between the 2481OWN bit and the 'next' bits is shown later. The receive buffers are handled in the same way using the Nrbuf (next receive buffer).

Table 3. A and B Buffers and Chaining

Ntbuf	2481OWN Buffer A	2481OWN Buffer B	Transmit Action
0	0	0	Send nothing
0	1	0	Host sets up buffer A
1	1	0	CD2481 accepts buffer A and marks B as next
1	0	0	CD2481 completes A tx, and passes it to host
1	0	1	Host sets up buffer B
0	0	1	CD2481 accepts B and marks A as next
0	1	1	Host sets up buffer A
1	1	0	CD2481 completes B tx, passes to host, accepts A and marks B as next
1	0	0	CD2481 completes A tx and passes it to host

Chaining is used to break up relatively long frames into shorter blocks in memory, and is useful where there are frequent smaller frames and occasional long frames. Chaining allows more efficient use of the user RAM.

The EOF Status bit is used to control chaining in Synchronous modes. Chaining applies to both transmit and receive. For transmit, the host determines EOF bit; for receive, the CD2481 determines the EOF bit.

In Transmit DMA, when the first buffer is supplied to the CD2481, it is treated as the start of frame — the CRC is reset and leading pad/flag/syn characters are transmitted, followed by the data. If the EOF bit is set, the CRC and closing flag/syn are appended, and the next buffer is again treated as the start of frame. If the EOF bit is not set, the CD2481 treats the buffer as the first part of a larger frame and chains into the next buffer (does not reset CRC); this process then continues until a buffer is supplied with the EOF bit set.

5.4.5 Transmit DMA Transfer

As in receive data transfers, two buffers are available for DMA transmit transfers. The ATBADR/ BTBADR and ATBCNT/ BTBCNT (Transmit Buffer Address and Transmit Buffer Count registers) contain the start address of and the byte count in the buffers. These registers are set by the host when initiating a transfer. The CD2481 makes a copy of the registers to perform the transfer, leaving the originals unchanged. Transfer of buffers between the host and the CD2481 is controlled by the ATBSTS/BTBSTS (Transmit Buffer Status) registers.

Buffers can contain either complete frames or blocks of data, linked together to form a complete frame or a block, or used in an Append mode to transmit data as it arrives from another process. The first two transfer types are Block mode transfers, the last is the Append mode, and both are described below. The management of the buffers reduces the processor overhead associated with short data transfers and increases the minimum response time requirements for frame-based transmissions.

Chain Mode Transfer

In this mode, the frame should be complete in buffers in memory before transmission is started. The Append Status bit should not be set; the Start of Frame bit must be set to begin transmission, and the Last Buffer bit must be set if this buffer is the last in a chained block or is a complete frame or a block.

When the CRC bit is set, the CD2481 generates and transmits a cyclic redundancy check word for the frame using the polynomial selected by the CPSR (CRC Polynomial Select register). A host interrupt is generated after the buffer is transmitted, if the Interrupt Required bit is set.

Transmit buffers can be chained to support large frames. To minimize bus usage, the first buffer of the chain should begin on an even address in host memory. The CD2481 begins fetching a frame from a buffer performing DMA transfer, reading two bytes at a time. The CD2481 cannot realign data between external memory and the FIFO. If one buffer of the chain ends on an odd address, the next buffer in the chain should begin on an odd address. Otherwise, only single-byte transfers are made for the rest of the buffer.

Append Mode Transfer

This mode is available for buffer A in Asynchronous mode only. If buffer A is set to Append mode, the host can enable the CD2481 to transmit data in the buffer before it is completely filled. The CD2481 starts transmitting new data when it is appended to the buffer.

This mode is useful for terminal echo routines that do not wait for a complete block to be formed before starting transmission. In this mode, transmission is started when the buffer is made available to the CD2481 by the host; the ATBADR[0–3] and the ATBCNT[L, H] are initialized. Subsequent triggering of DMA transfer occurs by programming the ATBCNT[L, H] with the accumulated byte count. The ATBCNT should be written as a 16-bit word in this case, to avoid confusion between 2-byte operations. The ATBADR[0–3] should not be reprogrammed during the Append mode. If the memory space has to be moved, the Append mode has to be disabled first. When the final data is added to the append buffer and ATBCNT has been updated, the host should set the AppdCmp bit in STCR. When the CD2481 has completed the final transmission, it clears the 2481OWN bit in the ATBSTS register, and generate an end-of-buffer interrupt. Only the A buffer can be used in the Append mode.

Figure 7. Transmitter A and B Buffers

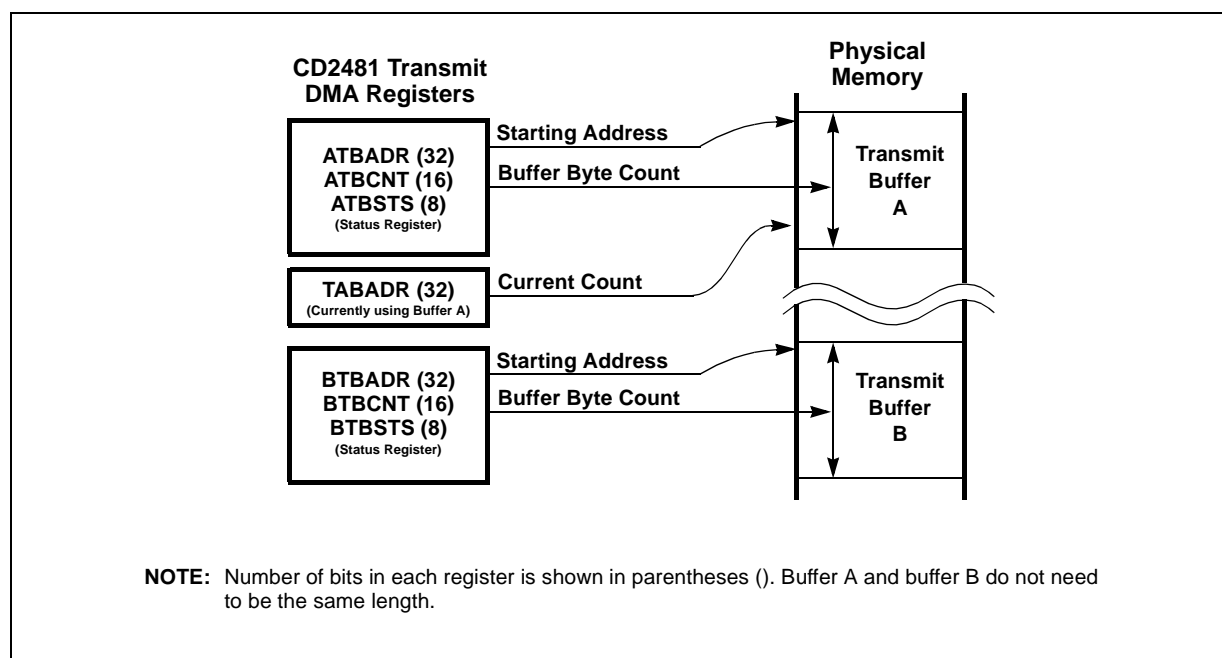

5.4.6 Synchronous Transmitter Examples

In Figure 7, buffers A and B are contained in RAM external to the CD2481. All else (DMABSTS, ATBADR, TCBADR, ATBCNT, ATBSTS, BTBADR, BTBCNT, and BTBSTS) is inside the CD2481.

Example 1

Transmit a frame out of channel 1, with no chaining.

1. The host checks the Ntbuf bit in the DMABSTS register for channel 1 to determine which buffer is next. In this example, Ntbuf is set to '0' indicating that buffer A is used next.
2. The host sets up the buffer data, the starting address — ATBADR, and the buffer byte count — ATBCNT.
3. The host then sets up the ATBSTS ('A' Buffer Status) register. The EOF bit is set to indicate that there is no chaining. The 2481OWN bit is set to give ownership to the CD2481. By setting 2481OWN, the host commands the CD2481 to start transmission. Thus, everything must be ready (starting address, buffer data, byte count) prior to setting 2481OWN.
4. The CD2481 starts frame transmission out of channel 1. When transmission is started, the CD2481 sets Tbusy bit in DMABSTS. As transmission progresses, the current buffer pointer, TCBADR, is updated by the CD2481. Also, at the start of transmission, the Next Buffer bit, Ntbuf, is set to '1' to notify the host that buffer B is next.
5. The CD2481 completes frame transmission by adding any necessary CRCs and trailing frame delimiters.

6. When the CD2481 completes the transmission, it clears the Tbusy bit. Then it sets the EOB bit and clears the 2481OWN bit in the ATBSTS. This notifies the host that the transmission is complete, and it returns ownership of the buffer back to the host.
7. The CD2481 optionally interrupts the host, with EOF and EOB in the TISR both set to indicate that the transmission is complete, and there was no chaining.

Example 2

Transmit out of channel 0, and chain three buffers into one frame. The frame is 240 bytes long, and the maximum buffer size is 100.

1. The host checks the Ntbuf bit in the DMABSTS register for channel 0 to determine which buffer is next. In this example, Ntbuf is set to '1' indicating that buffer B is used next.
2. The host sets up the buffer data, the starting address — BTBADR, and the buffer byte count — BTBCNT, for the first 'link' of the chain to be transmitted. For this example, BTBCNT is set to 100.
3. The host then sets up the BTBSTS ('B' Buffer Status) register. The EOF bit is clear to indicate that this buffer is the first link in a chain. The 2481OWN bit is set to give ownership to the CD2481. By setting 2481OWN, the host commands the CD2481 to start transmission. Thus, everything must be ready (starting address, buffer, data count) prior to setting 2481OWN.
4. At this point, the host has enough time to transmit 100 bytes to set up the next buffer link. If the host fails to do this in time, there is a transmitter underrun, and the frame is aborted in HDLC or bisynchronous.
5. The CD2481 starts transmitting buffer B from channel 0. When this is started, the Ntbuf bit is cleared to '0' to indicate that buffer A is next. This helps the host keep track of which buffer is next. As transmission progresses, the current buffer pointer, TCBADR, is updated by the CD2481. During this or prior, the host has made buffer A ready. For buffer A, the EOF bit in the ATBSTS register is cleared by the host, indicating that the buffer is not the end of the chain.
6. At the end of transmission of this buffer, the CD2481 does not add any CRCs nor end of frame delimiters because there is more data for the current frame.
7. After the CD2481 has completed transmission of the first link out of buffer B, the CD2481 sets the EOB bit and clears the 2481OWN bit in the BTBSTS. This notifies the host that the transmission is complete, and returns ownership of the buffer back to the host.
8. The CD2481 optionally interrupts the host with EOF clear and EOB set in the TISR to indicate that the transmission is completed, and that there was chaining.
9. The CD2481 now sees from the ATBSTS register that it has ownership of buffer A for transmission of the next 'link'. It also sees that the EOF is clear so that this link is not the last link in the transmitted chain.
10. The CD2481 continues transmission of the current frame, but now transmission is from buffer A. This is the second link, and is 100 bytes long. During this time, the host must set up a new buffer B for the third and final link. The BTBCNT for the last link is set to 40 bytes.
11. After the CD2481 has completed transmission of the second link out of buffer A, the CD2481 sets the EOB bit and clears the 2481OWN bit in the ATBSTS. This notifies the host that the transmission is completed, and returns ownership of the buffer back to the host. As with the first link, the CD2481 does not add CRCs nor ending frame delimiters to this link.
12. The CD2481 optionally interrupts the host with EOF clear and EOB set in the TISR to indicate that the transmission is completed, and there was chaining.

13. By this time, the host has set up a new buffer for buffer B. The EOF bit in the BTBSTS is set to indicate that this is the last link in the chain.
14. The CD2481 then transmits buffer B in the same manner shown above. As before, the CD2481 transmits the number of bytes indicated in the BTBCNT, which is 40 for the third segment.
15. When the CD2481 completes transmission, any necessary CRCs and ending frame delimiters are transmitted.
16. The CD2481 optionally interrupts the host with EOF and EOB set in the TISR to indicate that the transmission is complete, and this is the last link in the chain.

5.4.7 Receive DMA Transfer

In all protocol modes, two host memory buffers can be made available to each receive channel, by the ARBADR/BRBADR and ARBCNT/BRBCNT (Receive Buffer Address and Receive Buffer Count registers). To make a buffer available, the user must supply the buffer address in the Receive Buffer Address registers; the number of free bytes in the buffer must be written in the Receive Buffer Count registers, and the buffer status must be updated in ARBSTS/BRBSTS (Receive Buffer Status register). The CD2481 is then free to use the buffer for receive data, and update the Buffer Status register as appropriate. When the buffer is no longer in use, the CD2481 writes the number of bytes stored in the buffer in RBCNT and updates status in RBSTS. This frees the host to take control of this buffer and supply a new buffer in its place. The CD2481 automatically switches to the other buffer whenever one buffer becomes full, or the end of a frame has been reached. If the other buffer has not been allocated, the host still has the time required to fill the CD2481 16-byte FIFO in which to respond and avoid loss of data.

Special actions are taken depending on the channel protocol. In HDLC mode, the end-of-frame/data block boundaries are recognized by the CD2481. When a data-block boundary is detected, the current buffer is automatically terminated. If the other buffer is allocated and owned by the CD2481, it becomes the current buffer. End-of-frame and block interrupts are also generated to the host.

In Asynchronous mode, a host interrupt is generated when there are receive exceptions (framing error, special character, and so on), but the buffer is not terminated. The data and exception status are made available to the host, just as when the Asynchronous mode is purely interrupt-driven. New data is buffered internally in the FIFO until the host services the exception interrupt. The host has the following three options when terminating an exception interrupt:

1. The exception character can be discarded.
2. The buffer can be terminated, if it is then no additional interrupt would be generated. The transfer count is not provided in A/BRBCNT, but can be calculated by RCBADR (Receive Current Buffer Address).
3. A user-defined gap can be left in the buffer.

These selections are communicated to the CD2481 by the value written by the host to the Receive End of Interrupt register, when the Receive Interrupt service is completed. Leaving an 'n' byte gap enables the host to insert status of its own in the current buffer, while continuing to receive data in the same buffer. This eliminates the overhead of allocating a new buffer. The host must have noted the starting location of the gap while in the exception interrupt. This is done by reading the Receive Current Buffer Address register. The address in this register is guaranteed to be stable during the Receive Interrupt, and to point to the next free character location in the current DMA buffer. If the size of the gap supplied by the host is sufficient to fill or complete the current buffer, the CD2481

automatically switches to the other buffer and advances the Receive Current Buffer Address enough to complete the desired gap. The CD2481 readjusts data alignment in its internal FIFO as needed to maintain alignment with the external buffer.

Receiver A and B Buffers

In the following drawing, buffers A and B are contained in RAM external to the CD2481. All others (DMABSTS, ARBADR, ARBCNT, ARBSTS, RCBADR, BRBADR, BRBCNT, and BRBSTS) are inside the CD2481.

Figure 8. Receiver A and B Buffers

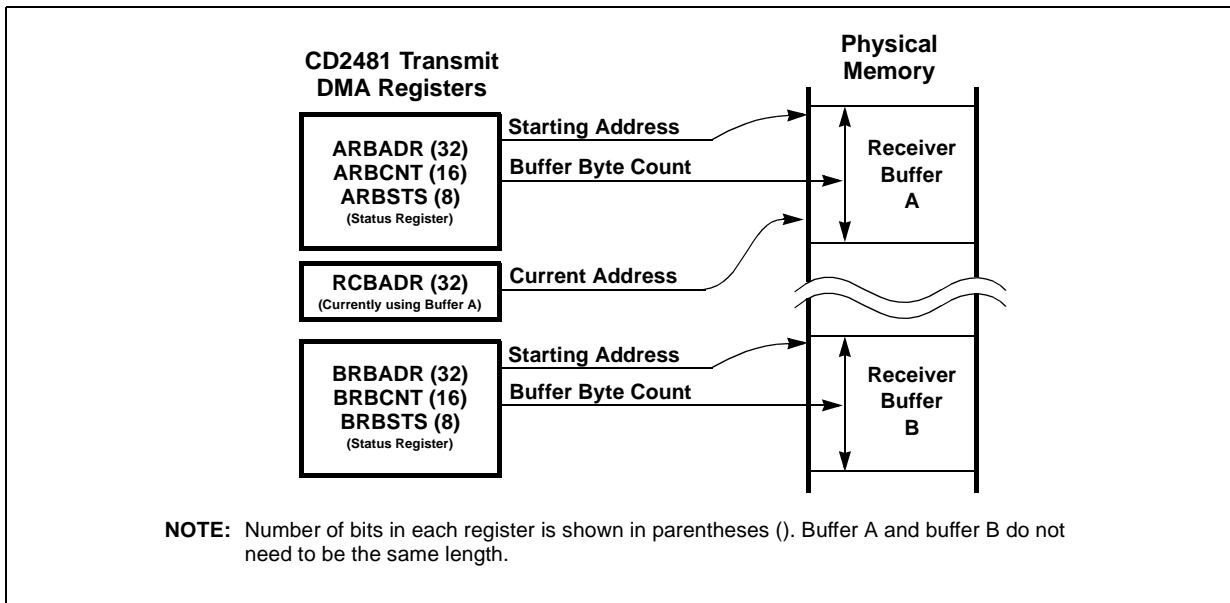

Example 1

Receive a frame from channel 1, no chaining.

1. The host must first make a receive buffer available before a frame can be received. Thus, the host checks the Nrbuf bit in the DMABSTS register for channel 1 to determine which buffer is next. In this example, Nrbuf is set to '0' indicates buffer A is used next.
2. The host sets up the starting address — ARBADR, and the buffer byte count — ARBCNT. When the host writes the count — ARBCNT, the host has defined the size limit for the buffer.
3. The host then gives the buffer to the CD2481 by setting the 2481OWN bit in the status register — ARBSTS. This notifies the CD2481 that it is now OK to write received.
4. The Rbusy bit in the DMABSTS register for channel 1 is '0' until a frame starts to be received. When frame data starts coming in, the CD2481 sets Rbusy to notify the host that buffer B is next. As data bytes are written into the buffer, the current buffer pointer, RCBADR, is updated by the CD2481.
5. At the end of the received frame, the CD2481 tests for correct end of frame delimiter and CRC. When the received frame is complete, the CD2481 clears the Rbusy bit. In this example, there is no receive chaining, so the received frame byte count is less than or equal to the buffer size count — ARBCNT. The CD2481 writes the value of the actual received byte count into

the same register — ARBCNT. (Recognize that the host has written the maximum buffer size in ARBCNT when the buffer is given to the CD2481, but when the buffer is returned to the host, the CD2481 has written the actual byte count of the received buffer into ARBCNT.)

6. The CD2481 sets the EOB and EOF bits. This notifies the host that the end of the buffer and frame have been reached. The CD2481 also clears the 2481OWN bit to give the buffer back to the host.

Example 2

Receive a frame on channel 0, which consists of three buffers chained together. The frame is 240 bytes long, and the maximum buffer size is 100.

1. The host checks the Nrbuf bit in the DMABSTS register for channel 0 to determine which buffer is next. In this example, Nrbuf is set to '1' indicates buffer B is used next.
2. The host sets up the starting address — BRBADR. Buffer size is set to 100 in this example. Thus, the host sets BRBCNT is set to 100.
3. The host then sets the 2481OWN bit to give ownership to the CD2481.
4. The host should know the amount of time it takes to receive 100 bytes, because this is the minimum time the host has to set up the next buffer link. If the host fails to do this in time, there is a receiver overrun, and the received frame is lost.
5. Suppose that the CD2481 starts receiving data into buffer B of channel 0. When this is started, the Nrbuf bit is cleared to '0' by the CD2481 to help the host keep track of which buffer is next. (During this time or prior, the host has made buffer A ready.)
6. After the CD2481 has received the first link of the frame into buffer B, it sets the EOB and SOB bits and clears the EOF bit. This indicates that the first link in a chain has been received. Also, the CD2481 clears the 2481OWN bit, and returns ownership of the buffer to the host.

For the first received link, the received byte count (BRBCNT) remains unchanged at 100, since the received data filled the buffer.

7. The CD2481 optionally interrupts the host with EOF clear and EOB set in the RISR to indicate that the received buffer is complete, and that there was chaining.
8. The CD2481 now sees from the ARBSTS register that it has ownership of buffer A for transmission of the next link.
9. As the frame continues to be received, the data goes into buffer A. This is the second link that is 100 bytes long. During this time, the host must set up a new buffer B for the third and final link.
10. After the CD2481 has received the second link into buffer A, it sets EOB bit and clears the 2481OWN bit in the ARBSTS. This gives ownership of the buffer back to the host.

As with the first link, the received byte count — ARBCNT, remains unchanged at 100 since the received data filled the buffer.

11. The CD2481 optionally interrupts the host with EOF clear and EOB set in the RISR to indicate that the received buffer is complete, and there was chaining.
12. By this time, the host has set up a new buffer for buffer B.
13. The CD2481 receives data into buffer B in the same manner explained earlier.

14. In this example, the third link does not fill the buffer. Thus, when the end of frame delimiter is detected by the CD2481, the value of 40 (for 40 received bytes) is written into the received byte count — BRBCNT.
15. Next, the CD2481 sets the EOB and EOF bits to show that the buffer is complete, and that this is the last link in the chain.
16. The CD2481 optionally interrupts the host with EOF and EOB set in the RISR to indicate that the received frame is complete, and this was the last link in the chain.

5.4.7.1 Buffer Allocation

The CD2481 contains two DMA descriptors that can be loaded by the CPU to specify transmit buffers. These descriptors are designated A and B, and each consists of a 32-bit address (A/BTBADR), a 16-bit count (A/BTBCNT), and an 8-bit status (A/BTBSTS).

The Status register contains an Ownership Status bit — 2481OWN. When this bit is set, the CD2481 owns the descriptor, and it should not be written to by the CPU. When the bit is clear, the descriptor is owned by the CPU.

When DMA is selected and the channel is enabled, the CD2481 waits for ownership of buffer A. When ownership of A is given by setting the 2481OWN bit, the buffer is transmitted, and then the ownership bit is cleared. The CD2481 waits for ownership of buffer B; this process continues, toggling between the two buffer descriptors.

The DMABSTS register contains a status bit (NtBuf) that informs the CPU of the next buffer to transmit to ensure that the CPU and CD2481 stay in synchronization. This procedure ensures that a pipeline of data is available for the CD2481 to send, maximizing the bandwidth utilization and minimizing the possibility of underruns. [Figure 9](#) on the following page illustrates this procedure.

5.4.7.2 Interrupts for Transmit DMA Buffers

Two types of transmit interrupts are available in DMA mode; they are enabled by the Interrupt Enable register (IER) and controlled by the TxD and TxMpty bits.

When the TxMpty interrupt is enabled, interrupts are generated when there is no transmit data available to send. For example, the TxMpty interrupt can be used by the CPU to determine when line turnaround can occur on half-duplex lines.

Normally, the TxDat interrupt is used to indicate the end of each transmit buffer. The interrupt is scheduled internally when the last data is read from the transmit buffer into the FIFO.

Because only one interrupt is generated for each buffer, the TxD bit in the IER register can be left permanently enabled. If interrupts are required selectively for individual buffers, the INTR bit in the A/BTBSTS registers can be used to selectively enable interrupts.

5.4.7.3 Chained Buffers

In Synchronous modes, when the frame size exceeds the maximum buffer size, a frame can be transmitted from a number of separate buffers. This is achieved simply by not setting the EOF bit in the A/BTBSTS (Transmit Buffer Status register) until the last buffer of the frame. The CD2481 transmits the buffers as one frame; it appends the CRC only when all the data is transmitted from the buffer with the EOF flag set.

If the above procedure for allocating buffers is used, the CPU has the transmission time of the last buffer to allocate the next to avoid possible underrun. The EOF bit in the Transmit Interrupt Status register is set for the interrupt associated with the last buffer.

Figure 9. DMA Transmit Buffer Selection

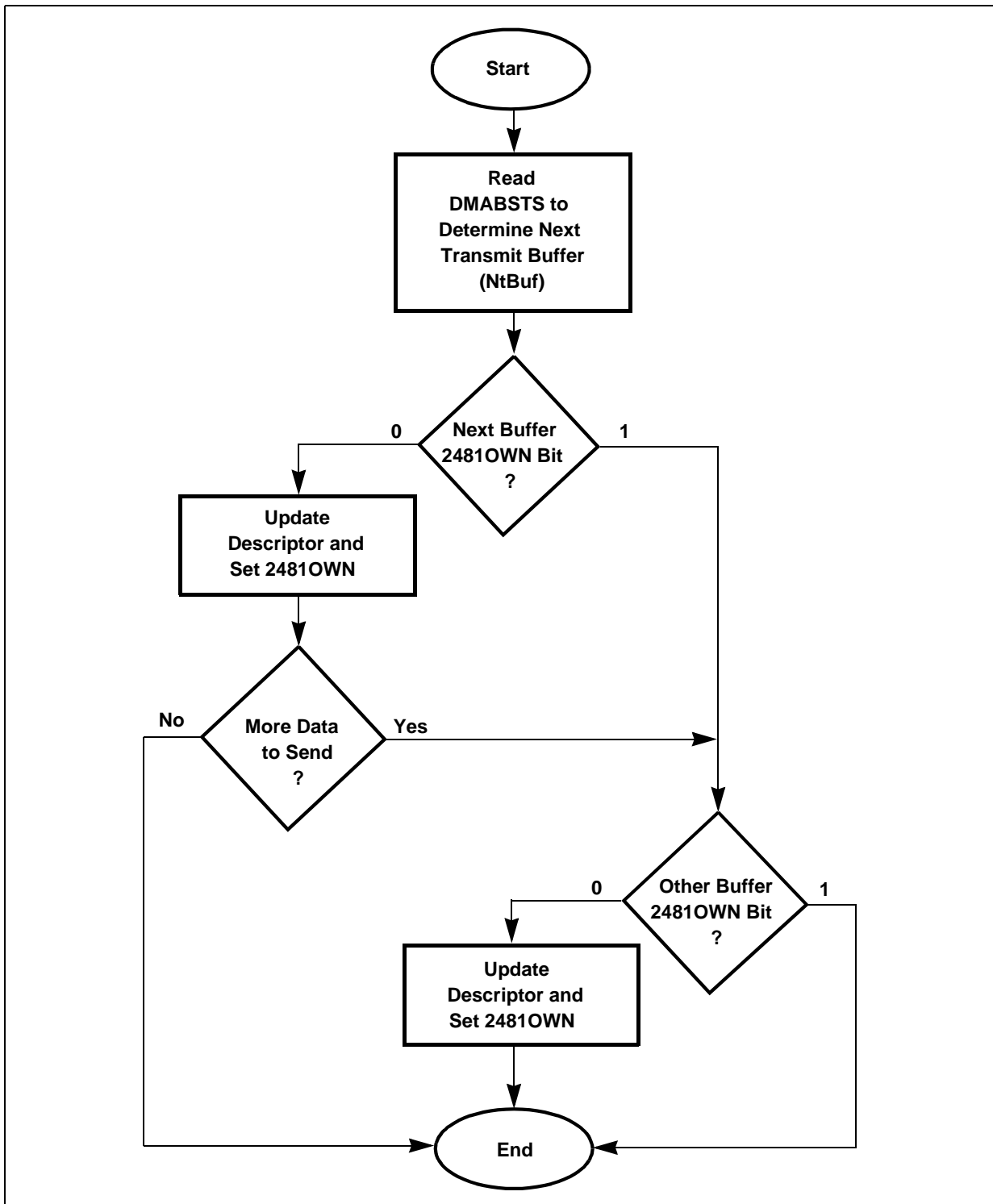

5.4.7.4 Append Mode

The Append mode reduces the CPU overhead required to provide asynchronous terminal echoing functionality; this is also necessary for any similar application that involves an unpredictable data stream. The A buffer can be set into Append mode by the ATBSTS register. This buffer can then be used for the echoed data, while the B buffer is used for all other output data. The append buffer allows data transmission to start from a buffer before all the data is available for transmission. For example, terminal echoing requires that each character is echoed (or translated and echoed) before the complete line is typed.

To operate in Append mode, the ATBADR and ATBCNT would be set as normal (the ATBCNT can be zero), and the 2481OWN and the Append bit set in the ATBSTS. When any data is available for transmission, it is placed in the RAM buffer by the CPU, and the total buffer byte count is updated in the ATBCNT. The CD2481 now scans the ATBCNT register for any changes; if new data is found, it is read from the buffer and transmitted.

When no more data is found in the append buffer, the CD2481 scans the B buffer for ownership. If the B buffer is owned by the CD2481, then the data in that buffer is transmitted uninterrupted; at the end of the transmission, the A buffer count continues to be scanned for new data.

For correct operation of this feature, the ATBCNT register should be updated with a word write operation. If only byte access is possible, the value should not exceed 256 bytes. This mode allows multiple transfers to be performed through a single buffer; it saves CPU overhead by either processing multiple buffers or in handling interrupts with every character.

Line retransmission becomes as simple as ‘stepping back’ in the buffer and resending. To terminate the Append mode, a command can be given by the STCR register that causes the A buffer to be terminated when all current data has been sent.

5.4.7.5 Transmit Bus Errors

When a transmit bus error interrupt is generated, the TISR and A/BTBSTS registers both indicate a bus error status. The current transfer address is available in the TCBADR[0–3] registers, and the bus error occurred on the last transfer that started at this address. This means the actual error address can be up to 16 bytes further in the buffer.

Following a bus error condition, the CPU has the choice of either discontinuing the current buffer or retrying from the start of the last transfer. To discontinue, the current buffer and the TermBuff bit should be set when TEOIR is written to at the end of the interrupt. In Synchronous mode, the frame is still in progress and needs to be aborted by the Special Transmit Command register (STCR).

To retry the frame, the CPU should set the 2481OWN bit in the ATBSTS/BTBSTS register, and not set the TermBuff bit when writing to TEOIR at the end of the interrupt. This causes the last transfer to be retried; should a bus error occur again, the above procedure is repeated. The CPU should check to ensure that a bad location is not continually retried.

5.4.7.6 Receive Buffer Interrupts

When a receive buffer is complete, the CD2481 generates an end-of-frame receive exception interrupt. It provides the CPU with RISR status and information on which buffer is complete.

When a receive error occurs, the device stops DMA at the point of error and generates a bus error receive exception interrupt. RISR indicates the cause of the exception, and RCBADR provides the next location in the receive buffer.

The CPU has the following five options:

1. Terminate the buffer.
2. Discard the exception.
3. Terminate the buffer and discard the exception.
4. Continue from the current position in the buffer.
5. Leave 'n' byte gap in the buffer and then continue.

The required option is written to the REOIR (Receive End-of-Interrupt register) by the CPU to terminate the interrupt. If the terminate buffer option is chosen, the 2481OWN bit in the A/BRBSTS register should first be cleared by the CPU, or a new buffer can be supplied by the CPU.

5.4.7.7 Receive Time-Out in Asynchronous DMA Mode

In Asynchronous DMA mode, the only way that the CD2481 releases the ownership is reaching the end-of-buffer. Receive time-out or any exceptions do not release the ownership if end-of-buffer condition is not met. The following illustrates recommended procedures to handle receive time-out in Asynchronous DMA mode.

Scenario 1: Buffer A is currently selected, receive time-out occurs, host wants to continue on.

Recommendation: Do nothing in the receive time-out interrupt service routine.

Scenario 2: Buffer A is currently selected, receive time-out occurs, host does not require DMA anymore.

Recommendation: Reset ownership bits in A(B) RBSTS, and set TermBuff in REOIR in the receive time-out interrupt service routine.

Scenario 3: Buffer A is currently used, receive time-out occurs, host wants to start DMA in buffer B.

Recommendation: Set TermBuff in REOIR in the receive time-out interrupt service routine. The CD2481 switches to buffer B.

Note: When a receive time-out occurs in buffer B, the CD2481 pops back to buffer A, unless the host clears both Ownership Status bits.

The above scenarios apply if buffer B is selected first.

5.4.7.8 Receive Bus Errors

When a receive bus error interrupt is generated, the RISR and A/BRBSTS registers both indicate a bus error status. The current transfer address is available in the RCBADR[0–3] registers, the bus error occurred on the last transfer that started at this address. This means that the actual error address can be up to 16 bytes further on in the buffer.

Following a bus-error condition, the CPU has the choice of either discontinuing the current buffer, or retrying from the start of the last transfer. If the buffer is to be discontinued, the number of valid receive bytes can be calculated by subtracting the starting address A/BRBADR[0–3] from the current address RCBADR[0–3]. The CPU should set the TermBuff bit in REOIR to terminate this buffer and move to the next.

The transfer that failed to the first buffer due to the bus error is still in the receive FIFO and is transferred to the next buffer following the end of interrupt.

To retry the buffer from the failure point, the CPU should set the 2481OWN bit in the A/BRBSTS register; the CPU should not set the TermBuff bit when writing to REOIR at the end of the interrupt. This causes the last transfer to be retried; should a bus error occur again, the above procedure is repeated. The CPU should check to ensure that a bad location is not continually retried.

5.5 Bit Rate Generation and Data Encoding

BRG and DPLL Operation

Data clocks are generated in the CD2481 by feeding one of a number of clock sources into a programmable divider. The clock source and divisor are programmable separately for each channel and direction by the user. Clock options are programmed in the Transmit Clock Option register and the Receive Clock Option register. The divisors are programmed in the Transmit Bit Rate Period register and the Receive Bit Rate Period register. The possible clock sources are:

Transmit

1. Clk 0 – CLK input/8
2. Clk 1 – CLK input/32
3. Clk 2 – CLK input/128
4. Clk 3 – CLK input/512
5. Clk 4 – CLK input/2048
6. TXCLK pin
7. Receive bit clock

Receive

1. Clk 0 – CLK input/8
2. Clk 1 – CLK input/32
3. Clk 2 – CLK input/128
4. Clk 3 – CLK input/512
5. Clk 4 – CLK input/2048
6. RXCLK pin

The CLK input is nominally 35 MHz.

The divisor can be programmed for values from 1–255. To maximize the accuracy of edge detection in Asynchronous and DPLL modes, the highest frequency clock and largest divisor combination should be selected.

An external clock input can be used, and it can be at a multiple of the desired bit rate. If so, the appropriate divisor value must be loaded into the Bit Rate Period register. If the external clock is at the desired bit rate, (1× clock) a value of 01h must be loaded into the associated Bit Rate Period register.

The receive bit rate generator can also be programmed to act as a DPLL (Digital Phase Locked Loop). In that mode, the clock select and divisor are programmed to be as near as possible to the nominal receive bit rate. Clock phase adjustments are made by the DPLL logic to lock to the incoming data stream. The receive bit clock is an optional input to the transmitter. This makes it possible to use the DPLL derived clock to synchronize the transmit data stream.

[Section 5.2](#) shows examples for programming standard bit rates. The value to be loaded to set a given bit rate is determined by the following equation:

$$\text{Bit rate divisor} = \frac{\text{Frequency of chosen clock source}}{\text{Desired bit rate}} - 1$$

Note: The above equation, in general, yields a non-integer result. The nearest integer value, along with the clock source, is the optimum choice for that bit rate. The value loaded in the period register must be that integer expressed as an 8-bit binary value. The bit-rate error is the difference between the integer value and the ideal value, expressed as a percentage.

Example 1

Illustrates programming the bit rate generator at 64 kbps using internal clock, at a system clock frequency of 35 MHz.

Divisor loaded into R/TBPR[†] = 67 or 43h
 Value loaded into R/TCOR = 00h, to select clk0

Example 2

Illustrates programming the bit rate generator at 56,000 bps using external clock. Again, the system clock frequency is assumed to be at 35 MHz.

The user provides a 1.25-MHz clock on the Rx Cin or Tx Cin pin.
 Divisor loaded into R/TBPR = 21 or 15h
 Value loaded into RCOR = 06h, to select External Clock mode
 Value loaded into TCOR = C0h, to select External Clock mode

[†]. R/T is used as a register abbreviation indicating Receive/Transmit followed by the register acronym.

Figure 10. Bit Rate Generator/DPLL

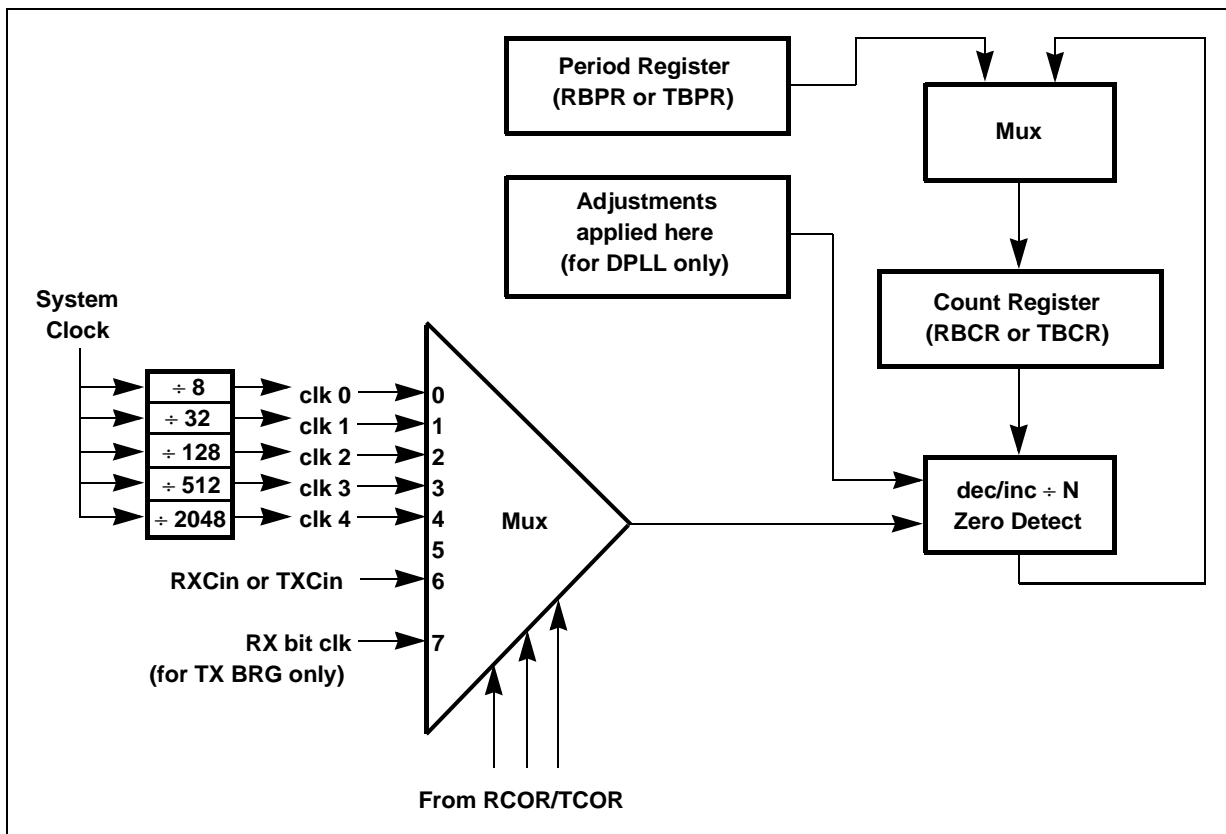

Receive Clock Option Register (RCOR)

CA C8 B R/W

TLVal	0	dpIIEn	Dpllmd1	Dpllmd0	ClkSel2	ClkSel1	ClkSel0
-------	---	--------	---------	---------	---------	---------	---------

Transmit Clock Option Register (TCOR)

C2 C0 B R/W

ClkSel2	ClkSel1	ClkSel0	0	Ext-1X	0	LLM	0
---------	---------	---------	---	--------	---	-----	---

Table 4. Clock Source Select (Sheet 1 of 2)

ClkSel2	ClkSel1	ClkSel0	Select
0	0	0	Clk 0
0	0	1	Clk 1
0	1	0	Clk 2
0	1	1	Clk 3
1	0	0	Clk 4
1	0	1	Reserved

Table 4. Clock Source Select (Sheet 2 of 2)

ClkSel2	ClkSel1	ClkSel0	Select	
1	1	0	External clock	
1	1	1	Reserved	(RCOR)
1	1	1	Receive clock	(TCOR)

Note: All divisors are in hexadecimal.

Table 5. Bit Rate Constants, CLK = 25 MHz

Bit Rate	Divisor	Clock	Error
50	f3	clk4	0.06%
110	6e	clk4	0.02%
150	50	clk4	0.47%
300	a2	clk3	0.15%
600	50	clk3	0.47%
1200	a2	clk2	0.15%
2481	50	clk2	0.47%
3600	d8	clk1	0.01%
4800	a2	clk1	0.15%
7200	6c	clk1	0.45%
9600	50	clk1	0.47%
19200	a2	clk0	0.15%
38400	50	clk0	0.47%
56000	37	clk0	0.35%
64000	30	clk0	0.35%
76800	28	clk0	0.76%

Note: All divisors are in hexadecimal.

Table 6. Bit Rate Constants, CLK = 30 MHz (Sheet 1 of 2)

Bit Rate	Divisor	Clock	Error
110	84	clk4	0.13%
150	61	clk4	0.35%
300	c2	clk3	0.16%
600	61	clk3	0.35%
1200	c2	clk2	0.16%
2481	61	clk2	0.35%
3600	40	clk2	0.16%
4800	c2	clk1	0.16%
7200	81	clk1	0.16%
9600	61	clk1	0.35%

Table 6. Bit Rate Constants, CLK = 30 MHz (Sheet 2 of 2)

Bit Rate	Divisor	Clock	Error
19200	c2	clk0	0.16%
38400	61	clk0	0.35%
56000	42	clk0	0.05%
64000	3a	clk0	0.69%
76800	30	clk0	0.35%
115200	20	clk0	1.38%

Note: All divisors are in hexadecimal.

Table 7. Bit Rate Constants, CLK = 35 MHz

Bit Rate	Divisor	Clock	Error
110	9a	clk4	0.23%
150	71	clk4	0.06%
300	e3	clk3	0.06%
600	71	clk3	0.06%
1200	e3	clk2	0.06%
2481	71	clk2	0.06%
3600	4b	clk2	0.06%
4800	e3	clk1	0.06%
7200	97	clk1	0.06%
9600	71	clk1	0.06%
19200	e3	clk0	0.06%
38400	71	clk0	0.06%
56000	4d	clk0	0.16%
64000	43	clk0	0.53%
76800	38	clk0	0.06%
115200	25	clk0	0.06%
12800	21	clk0	0.53%
134400	20	clk0	1.38%

Note: All divisors are in hexadecimal.

Table 8. Bit Rate Constants, CLK = 60 MHz (Sheet 1 of 2)

Bit Rate	Divisor	Clock	Error
150	c2	clk4	0.16%
300	61	clk4	0.35%
600	c2	clk3	0.16%
1200	61	clk3	0.35%
2400	c2	clk2	0.16%

Table 8. Bit Rate Constants, CLK = 60 MHz (Sheet 2 of 2)

Bit Rate	Divisor	Clock	Error
3600	81	clk2	0.16%
4800	61	clk2	0.35%
7200	40	clk2	0.16%
9600	40	clk1	0.16%
19200	81	clk0	0.35%
38400	40	clk0	0.16%
56000	2c	clk0	0.05%
57600	81	clk0	0.16%
64000	26	clk0	0.16%
76800	61	clk0	0.35%
115200	40	clk0	0.16%
128000	3a	clk0	0.69%
134400	37	clk0	0.35%
150000	31	clk0	0.00%
230400	20	clk0	1.38%

Transmit and receive data can be encoded and decoded in NRZ, NRZI, or Manchester formats. For NRZI, at the start of transmission, a learning data stream of contiguous zeros achieves bit synchronization; for Manchester, an alternating pattern of ones and zeros is required.

NRZ, NRZI, and Manchester — Data encoding schemes used in various synchronous protocols. In NRZ, the signal condition represents the data type, high for a logic 1 and low for a logic 0. In NRZ and NRZI type of encoding, the transitions of the data stream occur at the beginning of the bit cell. In NRZI, the signal condition switches to the opposite state to send a binary 0. In Manchester encoding, the transitions are always in the middle of the bit cell. A high-to-low transition is made to send a logic 1, and a low-to-high transition to send a logic 0. The following timing diagrams illustrate the encoding method. The data bits are 0110010.

Example 3

This example illustrates programming the Digital Phase locked loop at 128 kbps in NRZI mode using the internal clock, at a system clock frequency of 35 MHz.

Divisor loaded into R/TBPR = 33 or 21h
 Value loaded into RCOR = 28h, to enable the DPLL, NRZI framing and select clk0.

Example 4

This example illustrates programming the Digital Phase locked loop in the ×1 External Clock mode, with Manchester encoding.

Divisor loaded into RBPR = 01h, to enable ×1 external clock
 Value loaded into RCOR = 36h, to enable the DPLL, select Manchester framing, and external clock.

When using an n-times external clock, the highest possible clock frequency and largest divisor combination is recommended. The frequency of an external clock should be less than the system CLK input divided by 16, (that is, for 33-MHz operation, the data clock should be less than 2 MHz). Note that R/TBPR is an 8-bit register; therefore the largest divisor value is 255.

Use the following equation to compute the divisor value:

$$\text{Bit rate divisor} = \frac{\text{Frequency of external clock source}}{\text{Desired bit rate}} - 1$$

Figure 11. Data Encoding

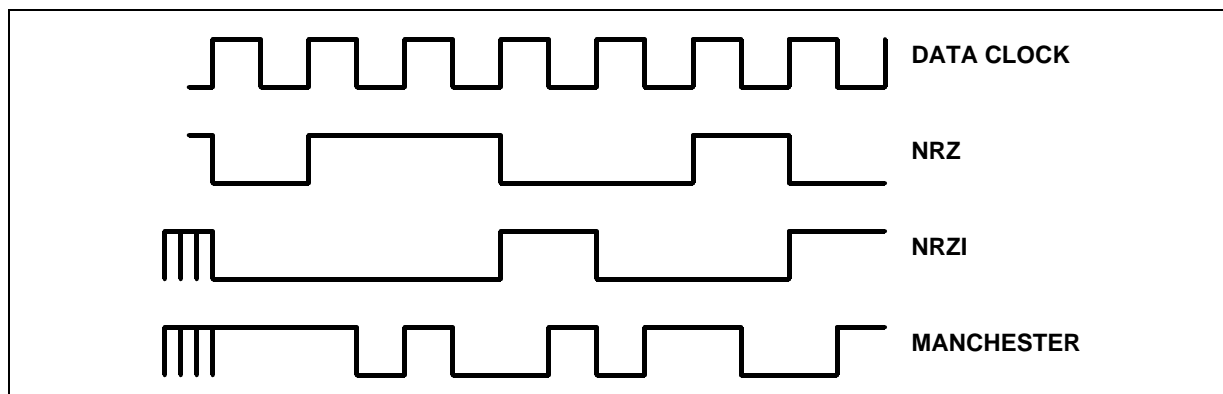
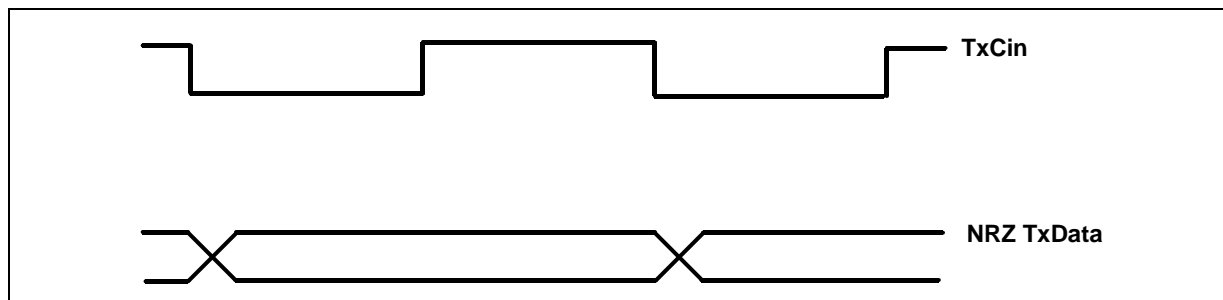

Figure 12. Transmit Data With External Clock In



NOTE: When using external receive clock in the Receive mode, data is sampled on the low-to-high going edge of RXCin.

Figure 13. Transmit Data With External Clock Out

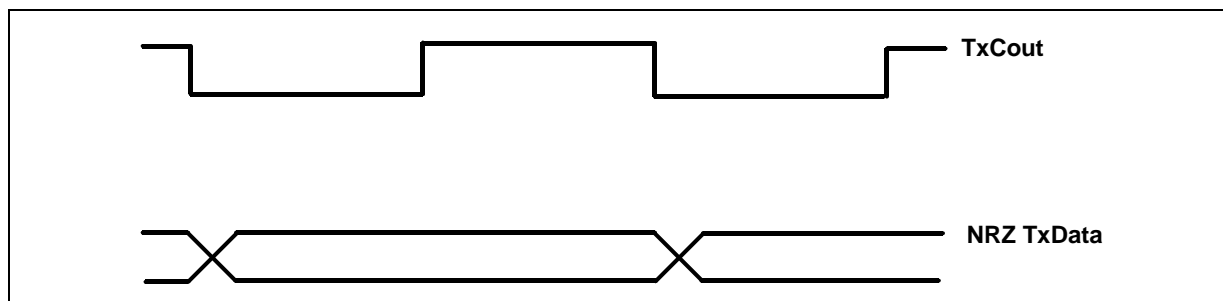

Table 9. Data Clock Selection Using External Clock

Bit Rate	External Clock Frequency	Divisor (hex)
Clock = 35 MHz		
50	9.765 kHz	C2
110	9.765 kHz	57
150	9.765 kHz	40
300	39.062 kHz	81
600	39.062 kHz	40
1200	156.250 kHz	81
2481	156.250 kHz	40
3600	625.00 kHz	EF
4800	625.00 kHz	81
7200	1.250 MHz	AC
9600	1.250 MHz	81
19200	1.250 MHz	40
38400	1.250 MHz	1F
56000	1.250 MHz	15
64000	1.250 MHz	12
76800	1.250 MHz	0F
115200	2.00 MHz	10
128000	2.00 MHz	0F

5.6 Hardware Configurations

To demultiplex the A/D[0–15] bus into separate address and data buses, external buffers and latches are required. To reduce external circuitry, these external devices can be shared in multi-CD2481 applications. The common control lines (ADLD*, AEN*, DATDIR*, DATEN*) to the external devices are wire-OR'ed together. These pins are tristate, not open collector, but an external pull-up resistor (2.2K–5.0K) must be connected to each line to ensure a logic '1' when no CD2481 is a bus master.

When no higher-priority alternate bus masters are present, a daisy-chain priority scheme can be implemented by wire OR'ing the BR* and BGACK* and connecting directly to the 680X0. The 680X0 BG* signal is then connected to the first device in the chain and daisy-chained to the remaining devices. A lower priority bus master can then be connected at the end of the chain.

If a higher priority bus master is present, the BG* signal must be qualified before being passed into the highest priority CD2481. If a priority encoded scheme is required, the BR* signals must be prioritized externally and BG* signals routed to individual devices.

5.6.1 Interface to a 32-Bit Data Bus

To interface to a 32-bit data bus, two 16-bit data buffers must be used to isolate the CD2481 A/D[0–15] pins from either half of the 32-bit bus. The A[1] address pin determines if the lower or upper half of the data bus is in use for a particular bus cycle. The CD2481 always drives all 16 data bits during a register read or a DMA write operation, regardless of the size of the actual transfer.

5.6.2 DMA Connections for the CD2481

Figure 14. DMA Connections for the CD2481

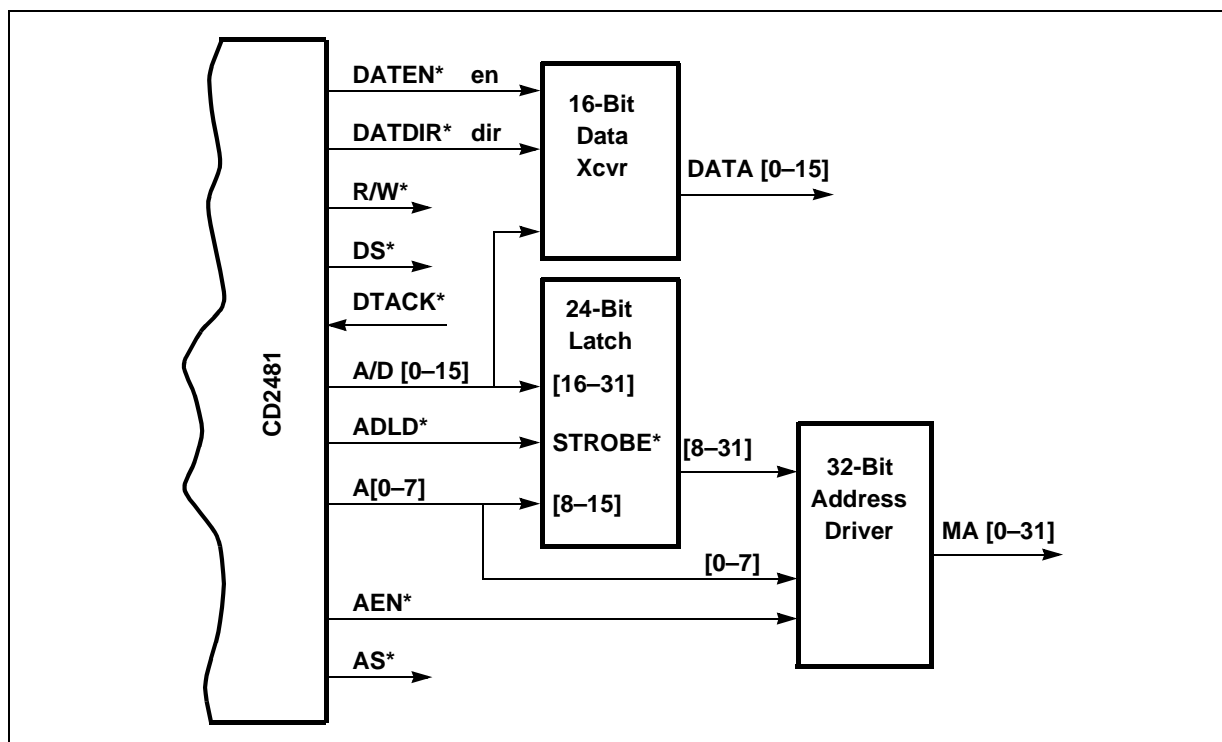

NOTES:

1. The 24-bit latch is REQUIRED.
2. The 16-bit transceiver is OPTIONAL depending on application.
3. The 32-bit driver is OPTIONAL depending on drive needs.

5.6.3 Recommended CD2481 as a DTE and DCE Interface

Table 10 shows the recommended DTE (data terminal equipment) connections between the CD2481 and RS-232-C, X.21 and X.21bis standard interfaces.

Table 10. DTE Connections

CD2481	RS-232-C	X.21	X.21bis (V.24)
RXD	BB	R	104
TXD	BA	T	103
RTS*	CA	C	105

Table 10. DTE Connections

CD2481	RS-232-C	X.21	X.21bis (V.24)
CTS*	CB	I	106
DSR*	CC	–	107
TXCOUT/DTR*	–/CD	–	108.2
RXCIN	DD	S	115
TXCIN	DB	S	114
RXCOUT	DA	–	113
CD*	–/CF	–	109

Table 11 shows the recommended DCE (data communication equipment) connections between the CD2481 and RS-232-C, X.21 and X.21 bis standard interfaces.

Table 11. DCE Connections

CD2481	RS-232-C	X.21	X.21bis (V.24)
RXD	BA	T	103
TXD	BB	R	104
RTS*	CB	I	106
CTS*	CA	C	105
DSR*	CD	–	108.2
TXCOUT/DTR*	DB/CC	S	114/107
RXCIN	–	–	–
TXCIN	DA	–	113
RXCOUT	DD	–	115
CD*	DA/–	–	–

NOTE: X.21 is completely different from X.21 bis.

Reference: CCITT 1988 Blue Book.

MPU Test Control Register - Write Only {MTCR} F3 F1 B W

7	6	5	4	3	2	1	0
n/u	n/u	n/u	n/u	n/u	TRAS	TMS1	TMS0

Bit 1:0 - Test Mode Select

TMS1	TMS0	Mode selected
0	0	Normal mode. Select internal ROM execution
0	1	Select auxiliary instruction.
1	0	Select emulation write mode.
1	1	Select emulation read mode.

The Auxiliary Instruction Registers hold the instruction that will be executed on the next instruction cycle. When single stepping, these registers are loaded with the desired instruction and then the single step command is issued.

 Auxiliary Instruction Register Low (write only) {AIRl} F0 F2 B W

7	6	5	4	3	2	1	0
Inst[7]	Inst[6]	Inst[5]	Inst[4]	Inst[3]	Inst[2]	Inst[1]	Inst[0]

 Auxiliary Instruction Register Middle (write only) {AIRm} F1 F3 B W

7	6	5	4	3	2	1	0
Inst[15]	Inst[14]	Inst[13]	Inst[12]	Inst[11]	Inst[10]	Inst[9]	Inst[8]

 Auxiliary Instruction Register High (write only) {AIRh} F2 F0 B W

7	6	5	4	3	2	1	0
n/u	n/u	n/u	n/u	n/u	n/u	Inst[17]	Inst[16]

6.1.2 Download Code Example

The following pages give a 'C' program example of how to perform a download operation. The code opens a file which contains the microcode data (stored in ASCII Hex format) and then sequentially loads the internal RAM with the data. The code requires that the microcode data be in contiguous form. The routine is written in Borland TurboC® for the MS-DOS environment; it should be easily ported to other environments. The microcode image is named "code_xx.hl", where

'xx' indicates the code revision number. Contact Basis Communications InterNetworking Products Applications Support at 'dcom-support@corp.basiscomm.com' for information on the latest microcode image.

```

#include<stdio.h>
#include<errno.h>
#include<dos.h>
#include<string.h>
#include<alloc.h>
#include<stdlib.h>
#include"2481_regs.h"/* File containing CD2481 register definitions */

void dl_setup( )
{
    outportb(btcr,0x01);/* stop the clock      */
    outportb(airl, 0xff);/* set jump 0x3fff instruction */
    outportb(airm, 0x3f);
    outportb(airh, 03);
    outportb(mtcr, 0x01);/* select auxiliary instruction */
    outportb(btcr, 0x03);/* do single step twice */
    outportb(btcr, 0x03);
    outportb(mtcr, 0x02);/* select data write mode - download */
}

void dload(ifp)
FILEifp;
{
    registerint i = 0;
    int    code1, code2, code3;
    char   *adrptr, *ptr;
    char   *strchr( ), *strtok( );
    char   buffer[120];

    /* Read data from file and separate into two byte-wide and one */
    /* 2-bit wide segments and place in aux. instruction registers. */

```

```

/* Once aux. instruction registers are loaded, execute store sequence. */

while (fgets(buffer,sizeof(buffer),ifp))    {

    adrptr = strtok(buffer, " \t");
    adrptr = strtok(NULL, " \t");
    sscanf(adrptr,"%1x%2x%2x",&code1,&code2,&code3);
    outportb(airl, code3%256);/* extract code into aux. */
    outportb(airm, code2%256);/* instruction registers */
    outportb(airh, code1%256);

    outportb(btcr, 0x03);/* single step to store in RAM */

    i++;
}

return(i);
}

void dl_start( );

{

    outportb(airl, 0xff);/* set jump 0x3fff instruction for restart */
    outportb(airm, 0x3f);

    outportb(airh, 03);

    outportb(mtcr, 0x01);/* select auxiliary instruction */
    outportb(btcr, 0x03);/* do single step twice */
    outportb(btcr, 0x03);

    outportb(mtcr, 0x03);/* execute from external RAM    */

    /* enable clock, begin executing from RAM code store */

    outportb(btcr,0x0);
}

main(argc, argv)

int argc;

char*argv[ ];

{

    switch (argc) {

```

```

    case 2:
        if ((ifp = fopen(argv[1], "r")) == 0) {
            printf("DL cannot open file: %s\n", argv[1]);
            exit( );
        }
        break;
    default:
        printf("Usage: dl filename.hl\n");
        exit( );
}
printf("Download setup...");
dl_setup( );
i = dload(ifp);/* do download */

printf("Downloaded %d (0x%x) lines of source code\n", i, i);

dl_start( );/* Start microcode */
printf("Program started.\n");
}

```

The file format of the microcode for the example software above is ASCII Hex; an example portion is shown below. The first column contains the address generated by the assembler, which is discarded by the download code, and the second column contains the microcode instruction.

```

00000  20D08
00001  208F0
00002  24030
00003  0D008
00004  228F0
00005  20C30
00006  22D10
00007  0200F
00008  1E000
etc.

```

7.0 Protocol Processing

The protocols supported by the device depend on the microcode image downloaded at boot time. This section describes all protocols included in the standard microcode image from Intel.

7.1 HDLC Processing

7.1.1 FCS (Frame Check Sequence)

The FCS is a 16 bit standard computation as used in HDLC, and defined in ISO 3309. This FCS algorithm is the same used with the synchronous HDLC operation of the CD2481. The basic characteristics of the FCS are as shown below:

Accumulation: FCS computation starts after the opening flag and continues to the closing flag.

Polynomial: The standard polynomial is:

$$x^{16} + x^{12} + x^5 + 1$$

Pre-load: The FCS 16-bit accumulator is preset to all '1's.

Transmit order: The FCS bits are identified as X15 to X0. The most-significant bit is X15, and is transmitted first. Thus, the first FCS character transmitted has bits X15–X8 in character positions D1–D8, respectively. The second FCS character has bits X7–X0 in character positions D1–D8, respectively.

Transmit polarity: Inverted.

Correct remainder: The receiver calculates the entire received frame, including the received FCS field. If the frame is received error-free, then the correct remainder in the FCS accumulation is 'F 0 B 8' (X15 is the leftmost bit).

The FCS can be individually enabled or disabled for the transmitter and receiver.

If enabled for the transmitter, the device appends the FCS on transmitted frames. If disabled, the device adds no FCS at the end of the frame.

If enabled for the receiver, the device computes the received FCS and reports the results. If the FCS buffer is enabled, the device includes the 2-byte FCS in the received data presented to the host. If disabled, the device does not test for received FCS.

7.1.2 HDLC Transmit Mode

The transmitter can be programmed to idle in either flag (0111110) or mark (continuous 1's) mode via Idle bit in Channel Option Register 3 (COR3). When idle in mark is selected, frame transmission can be programmed to be prepended by a programmable number of pad characters and a programmable number of flags. The pad character can be selected as either 00 or AA; the pad characters allow the remote receivers Phase Locked Loop to synchronize quickly to the data. When NRZI encoding is used, the 00 character guarantees a transition every bit time; for Manchester encoding, AA guarantees exactly one transition per bit time.

If the transmitter is idling in mark, frame transmission is started when data is made available to the transmitter, either via the TDR (Transmit Data register) or a DMA buffer. First the programmable number of pad characters are transmitted, then the programmable number of flag characters. Data characters are then transmitted and a CRC value accumulated using each data character.

When end-of-frame status is passed to the CD2481 via the TEOIR or the ABTBSTS/BTBSTS, and the remaining data is transmitted, the FCS (if enabled) and a closing flag will be appended to the frame. If a new frame is available immediately, the correct number of opening flags will be transmitted and data transmission started. If data is not available, the line will be returned to its idle condition.

If data underrun occurs, the CD2481 does not append an FCS, but aborts the transmission by sending eight continuous 1's, and then reverts to the idle condition. An underrun interrupt is generated, and, if interrupt transfer is being used, the CPU should provide an EOF response in TEOIR. If DMA Transfer mode is being used, the CD2481 discards DMA buffers until an EOF buffer is found; transmission then resumes from the next buffer. This ensures correct operation when a multiple buffer frame underruns.

When programmed in NRZI mode and idle in mark is selected, after the closing flag and the first eight ones are transmitted, the transmit data line is sampled to determine if it is a logic high or low. If it is low, an extra zero is transmitted to force the line to be a logic high.

When Idle in Flag mode is selected, the send pad and opening number of flags have no significance; transmission is started when data is first made available in the FIFO. If no data underrun occurs, the frame is terminated normally with an FCS, and then continuous flags are generated. If an underrun does occur, then no FCS is appended, eight ones are transmitted to abort the frame and then continuous flags and an underrun interrupt are generated.

7.1.3 HDLC Receive Mode

Once enabled, the receiver enters Flag Hunt mode. When the first flag is detected, the next non-flag/abort character is treated as the start of frame. If address recognition is not enabled, frame reception then continues; if address recognition is enabled, the incoming data is compared with the receive address registers, RFAR[1:4]. Two modes of address recognition are available:

1. The first byte of the address field only (four possible matches available against RFAR[1:4]).
2. The first *and* second byte the address field (two possible matches available against RFAR[1:2], RFAR[3:4]).

For the purposes of address matching, the HDLC Address Extension bit is not interpreted by the CD2481. The address matching occurs on either the complete first byte, or complete first and second byte of the frame. If no address match is recognized, Flag Hunt mode is once again entered, thereby discarding the current frame. If a match is found, normal frame reception continues. When the closing flag of the frame is detected, the data remaining in the FIFO is passed to the CPU, either through DMA transfers or good data interrupts, and then an EOF (End-of-Frame) interrupt is generated. The FCS can be either validated or ignored. If the CD2481 does not check the FCS, it will be passed onto the host. A validated FCS can be either discarded or passed onto the host for diagnostic purposes.

The next non-flag/abort character will restart the process. The current state of the receive process is visible to the CPU via the CSR register, which indicates whether data, flag or mark are currently being received. To support the Data Phase of an X.21 connection, a Clear Detect feature can be enabled via COR1. When enabled, the receive data and CTS* pin are monitored for the Clear

Indication (0, off) from the remote. If detected, the remainder of the current frame will be discarded, and a clear detect indication will be passed to the CPU via the RISR. However, the channel remains in HDLC mode until modified by the CPU.

7.2 PPP (Point-to-Point Protocol) Mode

7.2.1 Character Format

PPP uses the async-HDLC character format, which is fixed as one start bit, eight data bits, one stop bit. There is no parity bit. The character format is as shown in Figure 15.

Using the bit definitions from the standard format (Figure 15), the data bits are identified as D1–D8. D1 is the LSB. Characters are identified as either bits (D1–D8) or as hexadecimal values showing the hex value for bits D5–D8 first, followed by the hex value for D1–D4. Thus, a flag character is 01111110, and is indicated as a hex 7E. A control-escape character is 10111110, or 7D.

Figure 15. Character Format

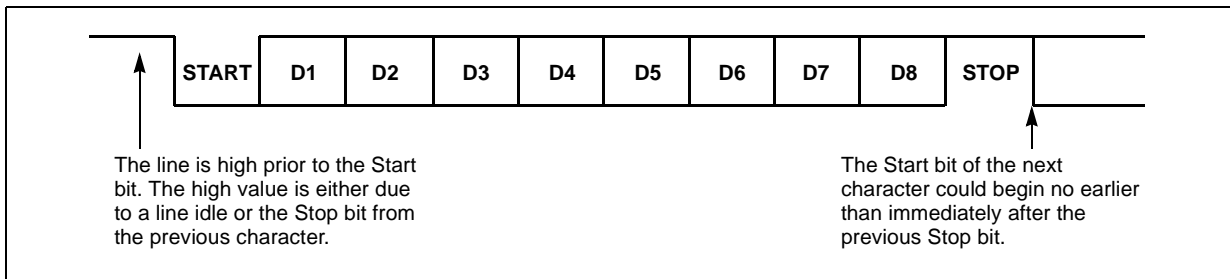

7.2.2 Frame Format

The standard frame format is as follows:

Figure 16. Point-to-Point Protocol Frame

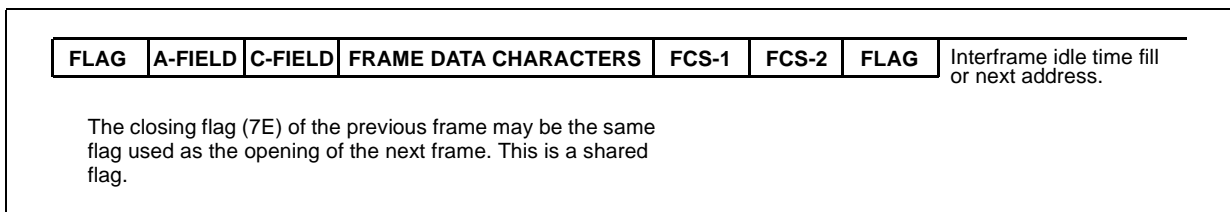

A and C fields

The chip passes the A and C fields to and from the host. The chip does not perform any special processing on these fields.

7.2.3 FCS (Frame Check Sequence)

PPP mode uses the same 16-bit CRC as standard HDLC mode (V.41).

Everything between the flags is included in the CRC calculation with two exceptions: control-escape (7D) characters added for transparency, and mapped characters received without a preceding control-escape. For mapped characters preceded by a control-escape, the FCS calculation is made after bit 6 is inverted.

7.2.4 Transparency

Transparency means that there is a protocol method to prevent confusion and ambiguity between control characters and data characters in the frame.

In PPP mode, there is a control-escape mechanism. Specific characters are identified as ‘control mapped’ characters. The control map is called the ACCM (async-control-character map). Whenever there is a mapped character in the data stream, the transmitter precedes that character with a hex 7D control-escape character. After the control-escape character, the character itself is transmitted with bit 6 inverted.

For example, if the character 13 is a mapped character, as identified by the corresponding ACCM bit, then the transmission of 13 is 7D–33.

When the receiver sees the 7D control-escape character, the 7D is removed, and bit 6 of the following character is inverted. The resultant reconstructed character is passed on to the host as one received character.

7.2.4.1 Mapped Characters from 00–1F

When a channel is selected for PPP, two ACCMs are assigned. Each ACCM consists of four registers (32 bits) to define mapped characters in the range 00–1F. One ACCM is for the transmitter (TXACCM), and one ACCM is for the receiver (RXACCM). Each bit within the ACCM points to a particular character within the range. When the bit is set, that character is a mapped character. Conversely, if the bit is clear, that character is not a mapped character.

As an example, suppose that the TXACCM bit pointing to the character 12 is set, and that the TXACCM bit pointing to the character 0B is clear. Then whenever a 12 is present for transmission, the actual transmission is 7D–32. Whenever a 0B is present for transmission, the 0B is transmitted without modification.

Continuing the example, suppose that the receiver ACCM bits pointing to 12 and 0B are also set and clear, respectively. Then, a received 12 (without a preceding 7D) is discarded, and a received 0B (without a preceding 7D) is passed through to the host unchanged.

7.2.4.2 Mapped Characters from 20 and Above

Three characters above 20 may be mapped. These characters are defined in the channel specific registers TSPMAP[1], TSPMAP[2], and TSPMAP[3].

7.2.4.3 Characters 7D and 7E as Transmitted Data

Whenever the transmitter sees either 7D or 7E as data for transmission, the transmitter treats these as mapped characters. Thus, a 7D as data is transmitted as 7D–5D, and a 7E as data is transmitted as 7D–5E.

7.2.4.4 Mapped Characters in the FCS Field

Whenever the transmitter sees that the FCS result to be transmitted contains a mapped character, the transmitter handles that character as any other mapped character. See [Section 5.3](#).

For example, suppose that an FCS field just happened to be A7–7E. In that case, the transmitter would send three characters in the FCS field: A7–7D–5E. The receiver would convert the received FCS back to A7–7E before completing the FCS computation.

7.2.5 Definition of a Valid Frame

Valid frames, from the viewpoint of the CD24XX chips, are:

All characters are formatted as in the standard async-HDLC format shown in [Section 7.2.1](#). When a channel is placed in the PPP mode, that channel transmits and expects received characters to be as shown in [Section 7.2.1](#). There is one exception of an option to transmit a framing error. See [Section 7.2.6.2](#) and [Section 7.2.6.4](#).

Async-HDLC and PPP protocols have requirements of minimum frame size. However, the CD24XX chips makes no requirement of a minimum frame size.

The frame opens and ends with a flag (7E). The chip complies with this in transmit, and requires opening and closing flags on the receiver. The closing flag from a preceding frame may be the same flag as the opening flag of the next frame. This is a shared flag. The chip can send and receive shared or non-shared flags.

The frame never ends with a control-escape followed by a flag (7D–7E). The chip does not send a 7D–7E at the end of a frame in the normal PPP mode. The chip may be commanded to send an abort of either a 7D–7E or a character with a bad stop bit.

If the chip receives a frame that ends in a 7D–7E, that frame is indicated to the host as being in error.

PPP requires transparency as described in [Section 7.2.4](#). When the channel is in the PPP mode, transparency is always enabled.

7.2.6 Transmitter

7.2.6.1 Fixed Transmitter Operations

For PPP mode, all transmitted characters are of the format shown in [Section 7.2.1](#), and the transmitter always sends an opening flag.

7.2.6.2 Transmitter Options

The device transmitter may be control-bit selected for options provided in the following table:

Option	Description
map32 (ATBSTS) (BTBSTS)	When map32 is set, all the characters in the TXACCM (00–1F) are mapped. All 32 characters are transmitted with a preceding 7D, and with bit 6 flipped. When clear, the normal TXACCM is used.
npad3, 2, 1, 0 (COR3)	The minimum number idle character times between transmitted frames is programmable from 0 to 15 character times.
TxGen (COR3)	If TxGen is set, the chip adds the two character FCS at the end of each frame. If TxGen is clear, the chip ends the frame with a closing flag after the last data byte from the host.
frame (STCR)	When commanded by setting the frame bit in STCR, the chip sends one character in the frame with the stop bit forced to 0.

7.2.6.3 Transmission of Abort

When commanded through the AbortTx bit in the Special Transmit Command Register (STCR[6]), the CD2481 ends the transmission of the current frame with an abort sequence of 7D–7E. After executing the abort, the CD2481 clears the STCR. The rules for shared flag transmission in [Section 7.2.6.2](#) are followed for the trailing flag (7E) of the abort sequence (7D–7E).

If the CD2481 is not sending a frame when the command bit is set, the chip clears the STCR, and sends no abort sequence.

7.2.6.4 Transmit Framing Error

For test purposes, one character with a framing error may be transmitted inside a frame. The Frame bit (STCR[2]) notifies the CD2481 to transmit one character with stop bit forced to 0. If the channel is transmitting a frame, one framing error character is inserted. After transmission, the channel continues with the frame transmission. After executing the command, the device clears the STCR.

If the CD2481 is not sending a frame when the command bit is set, the it clears the STCR, and sends no framing error character.

7.2.7 Receiver

7.2.7.1 Fixed Receiver Operations

The receiver is said to accept a frame or to accept a character when the received data are brought through the CD2481 and presented to the host.

In async-HDLC mode, the receiver accepts only characters of the format shown in [Section 7.2.1](#).

The receiver accepts only frames that have an opening flag. There may be more than one opening flag.

7.2.7.2 Receiver Options

The CD2481 receiver may be control-bit selected for the following options:

Option	Description
RxChk {COR3}	If RxChk is set, the receiver tests the FCS at the end of each frame, and reports the result. If RxChk is clear, the receiver makes no FCS computation.
RTPR	The RTPR timer is disabled when all bits are 0. RTPR is enabled with a non-zero value. See Section 4-5.

7.3 SLIP Processing

7.3.1 Framing

As defined in the original implementation, SLIP frames end with an ‘END’ character and have no beginning character. However, RFC-1055 suggests that all frames begin and end with ‘END’ characters. The CD2481 uses the ‘END’ character essentially as opening and closing flags. The defined characters (see table below) are fixed (hardcoded) and cannot be changed by the user.

Defined Character	Hex Encoding
END	0xC0
ESC	0xDB
ESC_END	0xDC
ESC_ESC	0xDD

The CD2481 uses the following conventions when transmitting a SLIP frame:

- When an ‘END’ character is to be sent, it is replaced by the character sequence ‘ESC’, ‘ESC_END’.
- When an ‘ESC’ character is to be sent, it is replaced by the character sequence ‘ESC’, ‘ESC_ESC’.

During receipt of a frame, the CD2481 makes the following substitutions:

- When an ‘ESC’ character is found in the data stream, only the ‘ESC_END’ and ‘ESC_ESC’ characters can follow. These two character sequences are replaced with a single character:
 - The sequence ‘ESC’, ‘ESC_END’ is replaced with ‘END’.
 - The sequence ‘ESC’, ‘ESC_ESC’ is replaced with ‘ESC’.
- Even though the characters ‘ESC_END’ and ‘ESC_ESC’ are the only valid characters following ‘ESC’, RFC-1055 suggests that when other characters are encountered, the ‘ESC’ should be discarded and the second character should be kept unmodified. The CD2231 follows this convention.

The SLIP protocol prohibits in-band flow control. As such, the CD2481 does not respond to XON and XOFF characters in any special way, they are treated as normal data.

7.3.2 Debugging Aids

For debug purposes, the CD2481 can send the sequence ‘ESC’, ‘END’, by setting the AbortTx bit (STCR[6]). This is intended as an abort frame function. The STCR also has a command for sending a bad (0 value) Stop bit, which causes a framing error at the receiving end (STCR[2]).

When the CD2481 receives the sequence ‘ESC’, ‘END’, it is reported as ‘receive abort’ in the RISR register. A bad Stop bit is reported as a FE (framing error) in the RISR.

7.4 MNP4[®]/ARAP Protocol Processing

7.4.1 Framing

An MNP4 (V.42) frame consists of a start flag, data octets, a stop flag, and a 16-bit FCS (frame check sequence). The FCS uses the polynomial $(x^{16} + x^{12} + x^5 + 1)$, preset to all ‘1’s, transmitted, and inverted. The character format uses asynchronous framing with 8 data bits, no parity, and one Stop bit. In-band flow control (XON/XOFF) is not permitted in this mode.

The start flag is a three octet sequence consisting of the start character, escape character, and STX (0x02). The stop flag is a two octet sequence consisting of the escape character and ETX (0x03).

During transmit, if an escape character is encountered in the data stream, it is duplicated. Conversely, the receiver discards the second of two sequential escape characters.

MNP4 is the data-link layer of ARAP 1.0 (AppleTalk™ Remote Access Protocol). ARAP 2.0 is the same as MNP4 except for the two start and escape characters.

The CD2481 uses two Special Character registers (SCHR1 and SCHR2) to hold the definition of the start and escape characters. There is no mode selection within the CD2481 that allows it to determine whether it is in an ARAP 1.0 or ARAP 2.0 environment. It builds and detects frames using the values in the two Special Character registers. The user must load the two Special Character registers with the appropriate start and escape characters for the version in use during channel initialization. The two special characters for each protocol are shown in [Table 12](#).

Table 12. Special Character Definition

Special Character Register 1 and 2	ARAP 1.0	ARAP 2.0
SCHR1 contains the start character	SYN	SOH
SCHR2 contains the escape character	DLE	ESC

For both versions of ARAP, frames begin with SCHR1, SCHR2, STX, and end with SCHR2 and ETX:

- ARAP 1.0— SYN, DLE, STX, data, data, data, ... DLE, ETX
- ARAP 2.0— SOH, ESC, STX, data, data, data, ... ESC, ETX

Both versions escape the escape character (in SCHR2) by duplicating it if it appears within the data stream.

7.4.2 MNP4[®]/ARAP FCS (Frame Check Sequence) Calculation

Both versions use the $(x^{16} + x^{12} + x^5 + 1)$ polynomial, preset to all '1's, transmitted and inverted with remainder equal to 0x1D0F. The frame body and ETX octet of the stop flag are included in the FCS calculation for both versions. The start flag and all DLE (ARAP 1.0)/ESC (ARAP 2.0) octets that are used for transparency are excluded from the FCS calculation. [Figure 17](#) and [Figure 18](#) illustrate the characters used in the FCS calculation. Data used in FCS calculation is in bold print.

Figure 17. ARAP 1.0 Frame

Start Flag			T				End Flag					
SYN	DLE	STX	data	data	DLE	DLE	data	data	DLE	ETX	FCS1	FCS2

Figure 18. ARAP 2.0 Frame

Start Flag			T				End Flag					
SOH	ESC	STX	data	data	DLE	DLE	data	data	ESC	ETX	FCS1	FCS2

Note: The DLE (ARAP 1.0) and ESC (ARAP 2.0) characters in the middle of the data stream, indicated by the 'T' column, are inserted for transparency and thus not included in the FCS calculation.

7.5 Async Processing

Data is transmitted according to the format options defined in the Channel Option registers. These options determine the character length, parity, and stop bit length. New data sent from the host will be transmitted in a continuous stream, unless one of the following happens:

1. Transmitter disabled – transmission terminated at the end of the current character until transmitter enabled.
2. XOFF received from line (if in-band flow control is enabled) – transmission terminated at end of the current character until XON received or transmitter enabled .
3. Out of band flow control (if enabled) – transmission terminated at the end of the current character until out of band flow control removed.
4. In-line command received in data stream from host – in-line command is executed and transmission resumed (if embedded commands are enabled).
5. Send special character command from host – the current character is completed and the special character is transmitted after which normal transmission resumes.

7.5.1 Transmitter In-Band Flow Control

For in-band flow control modes to be active, the Special Character Detect mode must be enabled.

Transmit in-band flow control is enabled when the Transmit In-Band Enable (TxIBE) bit in COR2[6] is set to one. When TxIBE is cleared to zero, in-band flow control is disabled, and the Implied XON Mode (IXM) COR2[7] has no meaning. The XON and XOFF characters are defined in the Special Character registers SCHR[1:2].

When in-band flow control is enabled ($TxIBE = 1$), and an XOFF character is received, the channel will stop transmission after the current character in the Transmit Shift register and the current character in the Transmit Holding register are transmitted. When $IXM = 0$, transmission will restart after an XON character is received. When $IXM = 1$, transmission will restart after any character is received.

The Flow Control Transparency (FCT) Mode bit ($COR3[5]$) is used to determine if the received flow control characters are passed to the host. If $FCT = 1$, the characters are not passed to the host. If $FCT = 0$, they are passed to the host as exception characters. This bit does not affect non-flow control special characters.

Additional status information about the state of transmitter in-band flow control is available in the Channel Status register (CSR). The Transmit Flow Off ($TxFloff$) and the Transmit Flow On ($TxFlon$) ($CSR[2:1]$) bits indicate the current state.

$TxFloff = 0$ is normal. $TxFloff = 1$ means that the channel has been requested by the remote to stop transmission. This bit is reset to 0 when the channel restarts transmission, as described above. This bit is reset to 0 when the transmitter is enabled or disabled, or the channel is reset.

$TxFlon = 0$ is normal. $TxFlon = 1$ means that the channel has been requested by the remote to restart transmission. This bit is reset to 0 once the channel has restarted transmission. This bit is reset to 0 when the transmitter is enabled or disabled, or the channel is reset.

7.5.2 Receiver In-Band Flow Control

The channel can request the remote to stop transmission by sending an XOFF character. Likewise, the channel can request the remote to restart transmission by sending an XON characters. The XON/XOFF characters is transmitted by setting the $SndSpc$ bit in $STCR$ to a 1.

The CSR contains status bits Receive Flow Off ($RxFloff$) and Receive Flow On ($RxFlon$) that are used for receiver in-band flow control.

$RxFloff = 0$ is normal. $RxFloff = 1$ means the channel has requested that the remote stop its transmission. This bit is reset to 0 when the channel requests the that the remote restart its transmission. This bit is reset to 0 when the receiver is enabled or disabled, or the channel is reset.

$RxFlon = 0$ is normal. $RxFlon = 1$ means that the channel has requested that the remote restart its transmission. This bit is reset to 0 when the next non-flow control character is received. This bit is reset to 0 when the receiver is enabled or disabled, or the channel is reset.

7.5.2.1 Automatic Receive In-Band Flow Control

The CD2481 can perform automatic in-band flow control, if desired. Automatic in-band flow control means that the device sends XON and XOFF characters based on the level of characters in the receive FIFO. This function is identical to the automatic out-of-band (hardware) flow control that uses the DTR bin.

As with automatic hardware flow control, when the number of characters in the FIFO exceeds the number programmed in $COR5[3:0]$, the automatic feature is activated and the CD2481 transmits an XOFF character (as defined by $SCHR2$). When the number of characters falls back to equal or below the programmed value, an XON character (as defined by $SCHR1$) is transmitted. The CD2481 keeps track of X-ON/X-OFF characters that it has sent so that erroneous flow control characters are not transmitted. For example, it does not transmit an XON simply because the number of characters is below the threshold; it only does so if it had previously sent an XOFF due

to the threshold being exceeded. For this reason, the user should not use the Send Special Character command in the STCR (Special Transmit Command register) to send XON/XOFF characters because the CD2481 does not keep track of flow control characters that it did not send automatically. The result could cause confusion on the other end of the connection due to conflicting flow control commands.

Automatic in-band flow control is functional only in standard Async and Async-HDLC/PPP modes; SLIP and MNP 4 expressly forbid in-band flow control. See the COR5 description for programming details.

7.5.3 Out-of-Band Flow Control

Receive out-of-band flow control is enabled when the CTS Automatic Enable (CtsAE) bit (COR2[1]) is set to 1. In this mode, character transmission begins only after the CTS* pin is active (low). In asynchronous transmission, if CTS* goes inactive (high) after transmission has started, the channel stops transmission after the current character in the Transmit Shift register, and the current character in the Transmit Holding register are transmitted. In synchronous modes, if CTS* goes inactive, the channel will stop transmission after the current frame. In either case, transmission will restart after CTS* becomes active again.

The CD2481 can automatically flow control the remote device via the DTR* pin. This mode is selected by setting a non-zero DTR* threshold in COR5 (COR5[3:0]); when both thresholds in COR4[3:0] and the threshold in COR5 are exceeded, the CD2481 will set the DTR* pin high. When the data in the FIFO falls below the DTR* threshold, the DTR* pin is automatically driven low.

Each channel of the CD2481 has four pins that can be used either as a modem control or general-purpose input/output pins. The modem signal names assigned to these four pins have been chosen to provide an easy reference for system designers. In fact, they are all simply general-purpose inputs and outputs (if automatic out-of-band flow-control is not used) that can be individually controlled or examined via the modem signal value register(s). Since the pins are general-purpose, system designers may choose to connect the pins in a manner that suits the application.

However, when the system software design employs automatic out-of-band flow control with the pins, then the signal naming convention no longer holds true in some cases, depending on whether the device is used as DCE or DTE. In this case, it is best to think of the pins in terms of their actual uses within the CD2481 and connect them accordingly, without regard to their names. The RTS* and CTS* pins are associated with transmitter and the DTR* and DSR* pins are associated with the receiver. The table below shows Intel recommended signal hook-up if automatic, out-of-band flow control is desired.

Mode		CD2481 Pin Name	Out-of-Band Flow Control
DCE	DTE		
CTS		DTR	Signal remote to transmit
RTS			Not implemented in this direction
	RTS	RTS	Request remote permission to transmit
	CTS	CTS	Enable transmitter

For example, if the CD2481 is designed to be DCE and automatic out-of-band flow control is desired, the pin DTR should be connected to remote CTS input. If the CD2481 is to be used as the DTE side, then the CD2481 CTS output would be connected to the remote CTS input.

Note that if automatic out-of-band flow control is implemented, the activity of DTR and DSR pins do not implement the function assigned to those signal names by the signalling conventions of the CCITT and other standards organization. These names would only apply to these pins if they are under program control and not under automatic CD2481 control. In fact, the “DTR” function enables the modem to go on- and off-line, depending on the state of the pin. If automatic control is used, then DTR would go inactive when the receive FIFO reached the programmed threshold thus causing the modem to drop the connection (carrier) to the remote, which would not be the correct function based on the state of the receive FIFO.

7.5.4 Line Break Detection and Generation

A line break on the receiver occurs when the input at the receive data (RxD) pin is all zeros (low) for at least one full character time. This is indicated when the Break bit (RISRI[0]) is set to ‘1’.

Line break generation out of the transmitter is possible when the Embedded Transmit Command (ETC) bit {COR2[5]} is set to 1. A line break is generated when the output at the transmit data (TxD) pin is all zeroes (low) for at least one full character time.

Line breaks may be transmitted by embedding certain sequences in the data stream, as defined in the table below. These sequences are valid for transmitting breaks only if ETC is set to ‘1’. The embedded sequences to transmit a break are listed below.

Sequence	Function
00h-81h	Send BREAK – Send a line break for at least one character time.
00h-82h-xxh	Insert Delay – To increase the break generation beyond one character time, the Insert Delay sequence may be used. The inserted delay will be xx, where xx is a binary number. The delay will be xx times the 'tick' set by the Timer Period register (TPR). The minimum period of TPR should be 1 millisecond. If the Insert Delay sequence is not preceded by a Send BREAK sequence, then there will be an inserted delay of all 1's (high) on the output for duration xx.
00h-83h	Stop BREAK – This must follow the Send BREAK sequence, or the Insert Delay sequence.
00h-00h	Send NUL – If the user needs to send a NUL character, and ETC = 1, the user may embed 00h-00h to send one NUL character. If there are less than 8-bits per character, the user may also send a NUL character by 'sending' an 80h.

Note: In addition to Insert Delay, a 'break' may also be increased beyond one full character by transmitting more than one 'Send BREAK' sequence at a time.

7.5.5 Special Character Transmission

Selected special characters may be sent preemptively by setting the SndSpC bit (STCR[3]). The CD2481 channel acknowledges the command by clearing the STCR. Along with the SndSpC bit, the host needs to set-up the three SSPC bits (STCR[2:0]), also in the STCR to select which character is to be sent.

When the host commands a special character transmission, the channel will complete transmitting any characters in the Transmit Shift register and Transmit Holding register, and then transmit the special character sequence. Any other characters awaiting transmission in the FIFO or through DMA will be transmitted after the special character.

If the transmitter is off due to in-band flow control, the special characters will override and be sent. Special characters will override out-of-band flow control. Also, if the transmitter is disabled, the special character send command will override, and the character will be sent.

Table 13. SSPC[x] Settings

SSPC2	SSPC1	SSPC0	
0	0	1	Send Special Character #1
0	1	0	Send Special Character #2
0	1	1	Send Special Character #3
1	0	0	Send Special Character #4
0	0	0	reserved
1	0	1	reserved
1	1	0	reserved
1	1	1	reserved

7.5.6 Special Character Recognition

Special character recognition is enabled when the SCDE bit COR3[4] is set to 1. The special characters are programmed in the SCHR registers, and are the same characters used for the transmitter.

If the FCT bit (COR3[5]) is set to 1, the channel process the flow control characters and discards them. Otherwise, if FCT = 0, the received flow control characters will be processed and passed onto the host via exception interrupt.

In the event of an error (framing and/or parity) in a received character sequence, the channel will not interpret this character as a special character. But, if an overrun condition occurred after a special character is detected, the new character is lost and the overrun status is set. In this condition, the CD2481 will give both an overrun exception and a special character recognition status.

7.5.7 Special Character Range

The Special Character Range low and high (SCRl and SCRh) registers define an inclusive range for special character recognition in the Asynchronous mode. It may be useful for identifying that a received character is within a certain range, such as a control character. To disable this function, if special character detection is enabled, make both SCRl and SCRh equal to SCHR1.

Special characters and range detection is through the three special character detect bits (RISRl[6:4]). The function of the SCdet[x] bits is listed below.

Table 14. SCdet[x] Settings

SCdet2	SCdet1	SCdet0	
0	0	0	No special characters/range detected
0	0	1	Special character 1 matched
0	1	0	Special character 2 matched

Table 14. SCdet[x] Settings

SCdet2	SCdet1	SCdet0	
0	1	1	Special character 3 matched if character 1 and 3 sequence not enabled
1	0	0	Special character 4 matched if character 2 and 4 sequence not enabled
1	1	1	The hex value of the receive character is within the range $SCRI \leq \text{receive character} \leq SCRh$.

7.5.8 UNIX Support Features

COR6 provides several functions useful in UNIX TTY drivers, to further reduce the amount of character-by-character processing the CPU is required to perform. Separate receive and transmit bits are provided to perform CR/NL (carriage return/new line) translations. In transmit NL can be converted to CR NL, or CR converted to NL. In receive, CR can be discarded, NL converted to CR, or CR converted to NL.

In receive processing, separate modes are provided to handle break and character error conditions. Break conditions can be handled in the normal way (via a receive exception interrupt), the condition can be discarded, or the break can be translated to a NULL (00) and passed as normal data to the CPU. Parity and framing errors can either be handled as normal (via receive exception interrupts), discarded, translated to a NULL (00) and passed to the CPU as normal data, or the character can be passed to the CPU as normal data, preceded by the sequence FF 00.

The LNext option (COR7[6]) provides a mechanism to transfer flow control and other special characters without invoking flow control or special character interrupts at the receiver. If the LNext option is enabled when the LNext character is received, the following character is just passed to the CPU as a normal character. The LNext character is programmed via the LNext register. The Strip feature (COR7[7]) strips the eighth bit off each error-free received character. It has no effect on the transmitted data. [Figure 19](#) shows the exact order of the CD2481 character processing steps in flowchart form.

Figure 19. CD2481 Receive Character Processing

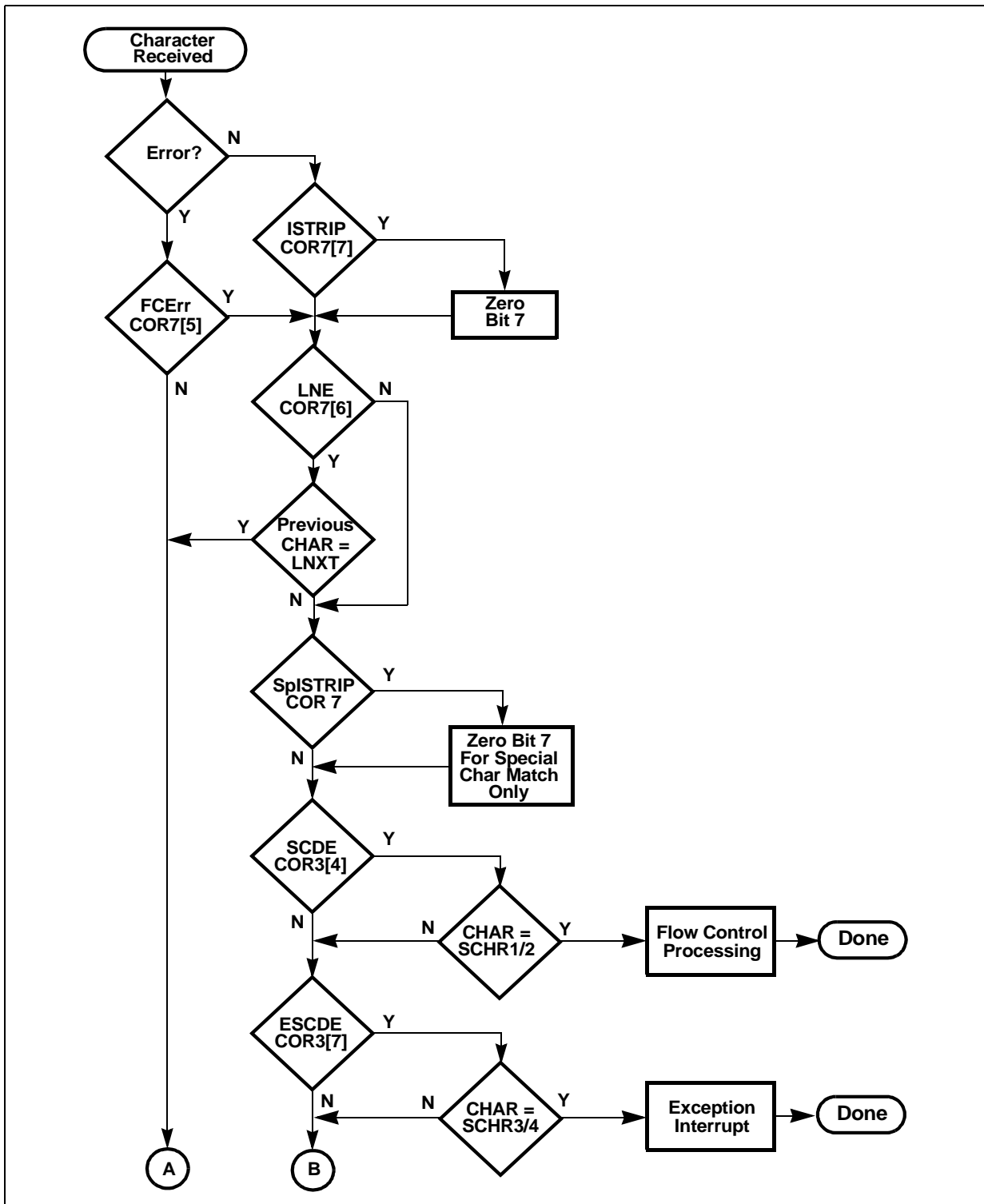



Figure 19. CD2481 Receive Character Processing (Continued)

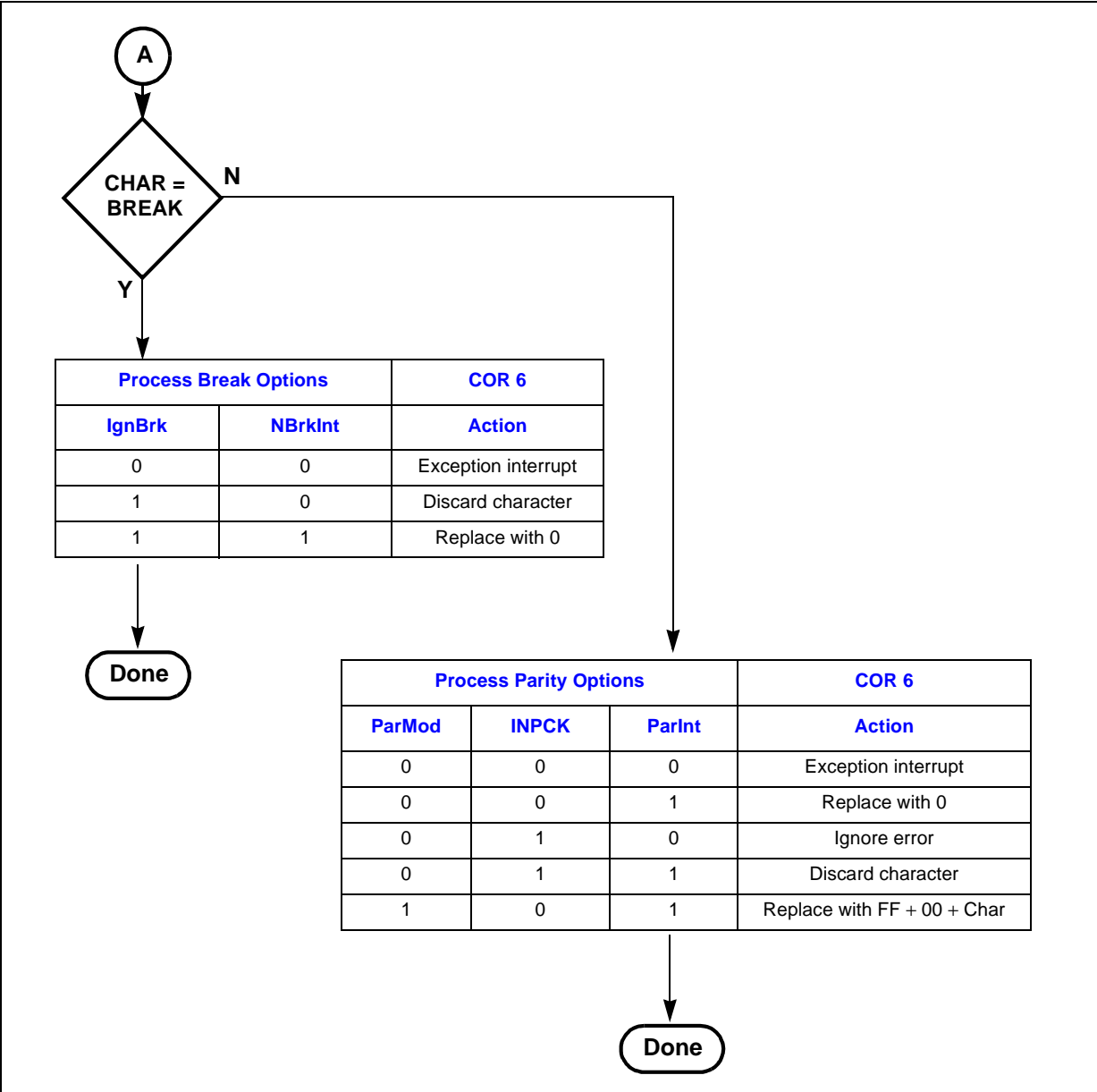
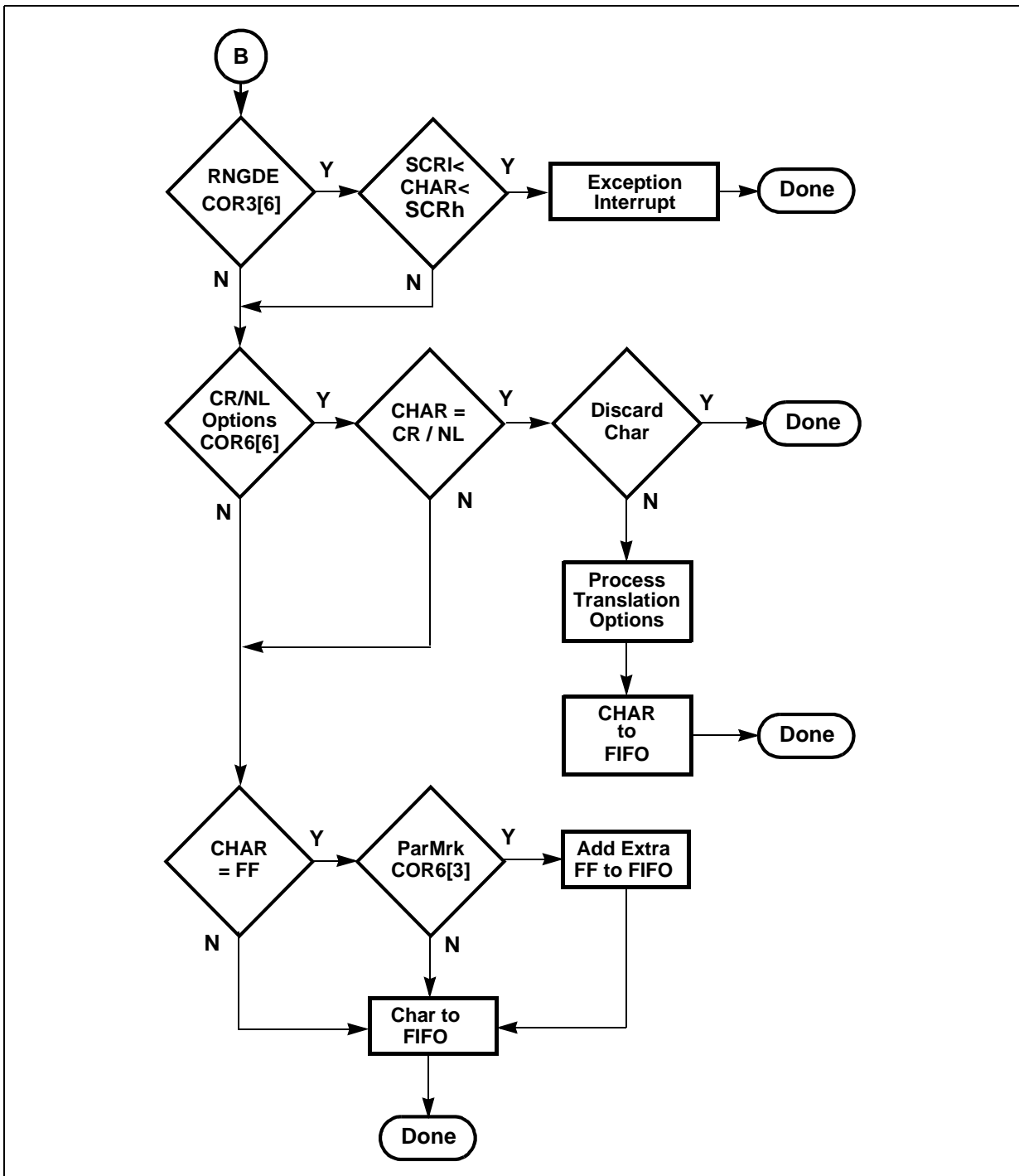

Figure 19. CD2481 Receive Character Processing (Continued)



7.6 Bisync Protocol

In both transmit and receive, the CD2481 interprets the first characters of data to determine the type of frame and compile the corresponding BCC. The host uses COR1 to program parity options and character length, and COR2 to program the character set (ASCII or EBCDIC) and determine whether to use CRC-16 or LRC.

7.6.1 Bisync Transmit Processing

The CD2481 can be programmed to idle in either SYN or mark. When idling in mark, a programmable number of leading pad characters can be transmitted before each data frame. The leading pads ensure the Remote Phase locked loop has sufficient transitions to achieve bit synchronization before data starts. The leading pad character can be programmed as AA (suitable for NRZ and Manchester), or 00 (suitable for NRZI).

When data is available in the FIFO, transmission will be started; any required leading pads will be sent, followed by a SYN pair and the CPU-supplied data. The CD2481 monitors the transmit data to determine frame type and compute the correct BCC, eliminating unnecessary characters from the calculation. If SYN sequences are embedded in the data supplied by the CPU, they will be transmitted — but excluded — from the BCC calculation.

If a frame transmission is aborted via the STCR, an EOT and trailing pad will be transmitted and the line returned to its idle state. A frame is terminated normally when an EOF indication is passed to the CD2481, either in TEOIR, or in the A/BTBSTS. If the frame ends with an EOT or ENQ condition, the trailing pad is appended and transmission is complete; otherwise, any accumulated BCC is appended, followed by the trailing pad, and the line returned to its idle state.

7.6.2 Bisync Receive Processing

After initialization, the receiver starts in Synchronous Hunt Mode, and will discard data until a pair of SYN characters are detected. The next non-SYN data is assumed to be the start of frame. The receive data is continuously monitored to determine the type of frame (transparent/non-transparent, BCC/no BCC). If required, the BCC is compiled, excluding any characters which should not be part of the calculation. When a frame terminating condition is detected, and if a BCC was accumulated, it is checked and the EOF information passed to the CPU via the RISRI. If the frame is terminated with an ENQ condition, the BCC is not checked, and an abort indication is passed to the CPU in RISRI.

An extra frame termination process is available by programming an extra-frame-termination character into COR6. When this character is detected, the receive frame is terminated immediately, and no BCC is computed. Following an initialize channel command, the COR6 is set to the value of DLE (10hex) by the internal code; the user may alter this to any other value. To detect the condition where the frame termination character has been corrupted on a non-transparent line, COR6 can be programmed to the idle condition FF hex. To use this on a transparent line, the data should not equal FF; if the value in COR6 is preceded by the DLE character, it does not cause frame termination.

Short Frame Processing

Short frames in Bisync mode are generally terminated with minimum two bytes of x'FF. The CD2481 reports these frames as follows:

Frame = SYN SYN STX ENQ FF FF

Reported as:

receive CRC error
receive abort

STX and ENQ are passed to host as data.

7.6.3 CRC Calculation in Bisync Mode

When in Bisync mode, there are several conditions under which the CD2481 varies the way it computes the FCS (frame check sequence) or BCC/CRC. The decision about which data is included in the current frame depends on how the previous frame ended and the transparency in the middle of a frame.

The following tables show the point in the current frame where the FCS computation begins, based on how the previous frame ended. From the start of a frame, when the previous frame ended in DLE-ITB, the following data streams have CRC computed as follows:

SYN	SYN	Data	Data
SYN	SYN	STX	Data
SYN	SYN	SOH	Data

From the start of a frame, when the previous frame did not end in DLE-ITB, the following four data streams have CRC computed as follows:

SYN	SYN	DLE	STX	Data
SYN	SYN	DLE	SOH	Data
SYN	SYN	SOH	Data	

Transition from non-transparent to transparent frame:

SYN	SYN	SOH	Data	Data	DLE	STX	Data

Within a non-transparent frame:

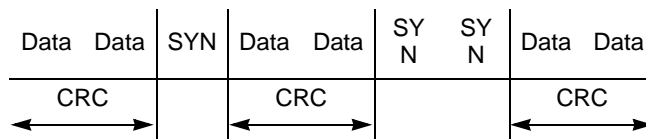

At the end of a non-transparent frame:

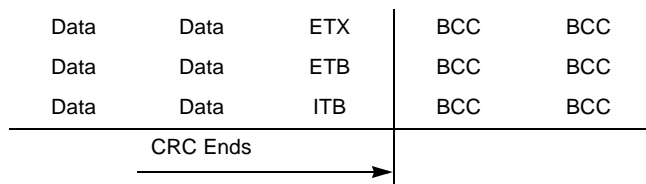

At the end of a transparent frame:

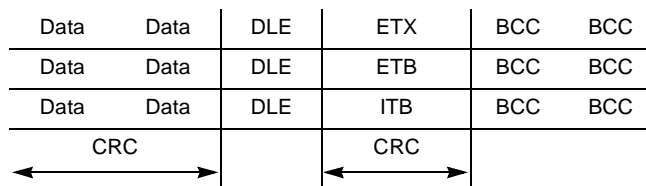

Note: For the transparent Bisync frames (receive only), the first DLE is not included in the CRC calculation, with the exception of DLE-SYN, in which the SYN is also not included.

Transparency Support

In transmit, the CD2481 generates CRC according to the tables earlier, however the host must insert the DLE manually in the data stream.

On receive, the CD2481 checks CRC according to the tables earlier, however it does not strip the DLE from the data stream.

7.6.4 BCC Computation Formulas

In Bisync mode, the CD2481 can use either CRC-16 or LRC. The mode used is determined by the setting of the LRC bit in COR2[7]. CRC-16 uses the polynomial:

$$x^{16} + x^{15} + x^2 + 1$$

preset to all zeroes. LRC performs a parity check on each bit of each character in the frame in a longitudinal or “vertical” manner. For example, in the following three byte frame, the LRC, with even parity, would be computed as shown:

Character 1:10010001
 Character 2:11000001
 Character 3:11000001
 LRC: 10010001

Note: If parity is used, parity is computed/checked on each character but the LRC of the parity bits is not checked.

7.6.5 Receive State Tables

The tables on the following pages show the Bisync state transitions with in the Bisync receive microcode character processing and the definition of the states.

Table 15. Bisync Receive State Transition (Sheet 1 of 2) (see “Key” on page 96)

Character Received	BGETHDR 0	BESCF 1	BESCL 2	BGETxT 3	BBCC 4	BBCC2 5	BWEOT 6	BXP 7	BDIS 8 ¹
SYN	0	hunt	7	3	5 CRC	CRC ²	6	7 CRC	8
DLE, RxITB = 0	1 i	hunt	7 CRC	1 CRC	5 CRC	CRC ^b	6	2	8
DLE, RxITB = 1	2 i CRC	hunt	7 CRC	1 CRC	5 CRC	CRC ^b	6	2	8
ENQ, SOHf = 1	hunt	hunt	hunt	hunt Abort 0-RxITB	5 CRC	CRC ^b	6	7 CRC	8
ENQ, SOHf = 0 STXf = 0	hunt	hunt	hunt	hunt 0-RxITB	5 CRC	CRC ^b	6	7 CRC	8
ENQ, SOHf = 0 STXf = 1, no data	hunt	hunt	hunt	hunt 0-RxITB 'TTD'	5 CRC	CRC ^b	6	7 CRC	8
ENQ, SOHf = 0 STXf = 1, data	hunt	hunt	hunt	hunt Abort 0-RxITB	5 CRC	CRC ^b	6	7 CRC	8
EOT, SOHf = 1	hunt	hunt	7 CRC	3 CRC	5 CRC	CRC ^b	6	7 CRC	8
EOT, SOHf = 0 STXf = 0	hunt	hunt	7 CRC	hunt	5 CRC	CRC ^b	6	7 CRC	8
EOT, SOHf = 0 STXf = 1	hunt	hunt	7 CRC	3 CRC	5 CRC	CRC ^b	6	7 CRC	8
STX	3 i ³ 1-STXf	7 ⁴	7 CRC ⁵	3 CRC	5 CRC	CRC ^b	6	7 CRC	8
SOH	3 i ^c 1-SOHf	hunt	7 CRC	3 CRC	5 CRC	CRC ^b	6	7 CRC	8
ETX RxITB = 1	4 CRC 0-RxITB	hunt	4 CRC 0-RxITB	4 CRC 0-RxITB	5 CRC	CRC ^b	6	7 CRC	8
ETB RxITB = 1	4 CRC 0-RxITB	hunt	4 CRC 0-RxITB	4 CRC 0-RxITB	5 CRC	CRC ^b	6	7 CRC	8
ITB	6	hunt	4 CRC 1-RxITB	4 CRC 1-RxITB	5 CRC	CRC ^b	6	7 CRC	8
ETX RxITB = 0	6	hunt	4 CRC 0-RxITB	4 CRC 0-RxITB	5 CRC	CRC ^b	6	7 CRC	8

Table 15. Bisync Receive State Transition (Sheet 2 of 2) (see “Key” on page 96)

Character Received	BGETHDR 0	BESCF 1	BESCL 2	BGETXT 3	BBCC 4	BBCC2 5	BWEOT 6	BXP 7	BDIS 8 ¹
ETB RxITB = 0	6	hunt	4 CRC 0-RxITB	4 CRC 0-RxITB	5 CRC	CRC ^b	6	7 CRC	8
PAD	6	hunt	7 CRC	3 CRC	5 CRC	CRC ^b	hunt 0-RxITB	7 CRC	hunt
none of above RxITB = 0	6	hunt	7 CRC	3 CRC	5 CRC	CRC ^b	6	7 CRC	8
none of above RxITB = 1	3 i CRC	hunt	7 CRC	3 CRC	5 CRC	CRC ^b	6	7 CRC	8

- 1.The BDIS¹ state is entered on receipt of error.
- 2.In the BBCC2 state, if RxITB = 1, go to state BGETHDR, else go to syn hunt.
- 3.If RxITB = 1, then calculate BCC, else do not calculate BCC.
- 4.If SOHf-1 and EBCDIC, then calculate BCC, else do not calculate BCC. If in ASCII/LRC mode, initialize BCC. Else do not calculate nor initialize BCC.
- 5.If in ASCII/LRC mode, but overridden by the DLE-STX, then initialize BCC, else calculate BCC.

Key

- hunt = Go to syn hunt state
 i = initialize BCC
 CRC = calculate CRC
 0 = clear state flag for example, 0-RxITB clears the RxITB flag
 1 = set state flag
 STXf = STX first flag
 SOHf = SOH first flag

Note: When returning to the syn-hunt state, RxITB is cleared.

Equation 1. State Descriptions

Number	Name	Description
0	BGETHDR	SYN-SYN received, and looking for next non-SYN character.
1	BESCF	The first DLE after opening SYNs has been received.
2	BESCL	A DLE has been received, but not the first for this frame.
3	BGETXT	The first non-SYN character after opening SYNs has been received, and that first character is either: STX, SOH, or a non-organized character if RxITB=1.
4	BBCC	A proper end of text has been received, and the channel is ready for the first BCC character. The things considered proper are: ETX, ETB, or ITB in non-transparent. Or, DLE-ETX, DLE-ETB, or DLE-ITB in transparent.
5	BBCC2	The first BCC character has been received, and the chip is ready for the second BCC character.
6	BWEOT	Continue receiving in this state until a PAD is detected.
7	BXP	Transparent receive. Look for escape DLE. Else, keep receiving.
8	BDIS	Disconnect state. Nothing being received. Remains in this state until a PAD is received.

NOTES:

1. The syn hunt state not shown. The syn hunt state consists of two sub-states that look for a received SYN-SYN pattern. Upon receiving SYN-SYN, the state moves to BGETHDR.
2. Conditions for the state table:
 - Bisync
 - Receive

7.7 X.21 Call Set-Up Mode

The X.21 call setup protocol uses a combination of synchronous data and control leads to control call progress, between a DCE and a DTE. The data can be in the form of steady state conditions (all '1's, all '0's, alternating '1's and '0's) or character synchronous data. The control leads are used in conjunction with the steady state data conditions to pass change of state information between the DCE and DTE. To enable detection of the steady state conditions, the SSDE bit (COR3[4]) must be set.

7.7.1 X.21 Transmit

To minimize the CPU intervention in the transmit direction, a modified version of the ETC (embedded transmit command) is used. ETC mode is controlled by COR2. When enabled, ETC mode provides a means of transmitting steady state, or repetitive data patterns synchronized to the control lead. The ETC consists of a sequence of four bytes passed to the CD2481 as normal transmit data, with the following format:

Table 16. ETC Byte Sequence

Byte 1	This byte must be 80 hex to indicate the start of a command sequence.
Byte 2	This byte indicates the required state of the control lead 00 = sets the control lead off 01 = sets the control lead on 02-FF = reserved.
Byte 3	This byte the is data character to be transmitted, and is transmitted as is, with no parity added. If parity is required, it must be included in the byte (that is, to transmit '+' with odd parity, the value AB would be loaded).
Byte 4	This byte is a count of the number of times to transmit the character. If the count is '0', the character are sent indefinitely until new data is made available (this would be the normal mode for the steady state conditions). In this case, when the count is '0', the CD2481 always sends the data a minimum of three times even if new data is made available sooner.

7.7.2 X.21 Receive

In receive, the CD2481 validates the steady state conditions, passing just the change of state information to the CPU. Steady state conditions validated are:

- All '1's
- All '0's
- Alternating '1's and '0's
- SYN the characters programmed in SCHR[1-3].



To be validated, a condition must be present for two character times with a stable value on the CTS* pin (CTS* is used in X.21 as the 'I' lead in a DTE or 'C' lead in a DCE).

For X.21, the SSDE bit (COR3[6]) must be set to enable the detection of the steady state conditions; this enables the detection of the all '1's, all '0's and the alternating '1's and '0's conditions with a stable value on the CTS* pin. When the SSDE bit is set, the StrpSyn and SCDE bits (COR3[5:4]) can also be set, if required (if SSDE is not set then the StrpSyn and SCDE bits have no effect).

Note: The SglSyn bit COR3[7] must be '0' because X.21 mode always requires two SYN characters for synchronization.

Enable the SSDE and StrpSYN bits to prevent SYN characters from entering the receive data FIFO. When set, the StrpSYN bit treats SYN characters the same way as steady-state conditions (that is, when two valid SYN characters are detected, a receive special character interrupt is generated and the next SYN characters are stripped from the incoming data stream). If the StrpSYN bit is not set, the SYN character is still used to achieve character synchronization, but all received SYN characters are passed to the CPU as normal receive data.

The SCDE bit enables the detection of the special characters defined in SCHR1–3 the same way as steady-state conditions. When detected for two consecutive character times, a special character detect interrupt is generated and the next repetitions of the same character are stripped from the receive data (for example, to detect the 'BEL off' condition for a DTE incoming call, then strip that repetition until the next state change). Character synchronization must be achieved before SCHR1–3 can be detected.

In certain phases of X.21 call setup, there is no character synchronization. When a data change occurs in a non-character synchronous phase, a partial character can be detected before the steady is detected or character sync is achieved. In these conditions, the partial character is passed to the host as normal data.

Note: The CD2481 passes all data it receives to the host prior to receiving SYN characters.

Example:

Assume SSDE, StrpSyn, and SCDE bits in COR3 are set, i.e., the CD2481 detects steady-state conditions, strip SYN and special characters from the incoming data. Under these conditions, the following data stream:

Incoming Data:

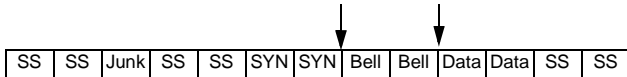

Where SS = Steady State Condition.

Note: A SYN Character Detect interrupt is generated after the second SYN. A Special Character Detect interrupt is generated after the second Bell

The incoming data is passed to the host as follows:



7.8 Extended X.21 Mode

Proper selection of options can extend the X.21 mode for some synchronous applications. Extended X.21 mode does not perform a true programmable sync mode, because the Extended-X.21 mode keeps passing characters to host though it is in SYN Hunt mode.

7.8.1 Extended X.21 Transmit

Without the ETC (COR2[5]) enabled, the data supplied to the channel is transmitted unaltered. When no data is available in the transmit FIFO, the ASCII SYN Character (16) is sent to fill idle time; this is the normal operating mode of X.21. If some other character is required to idle the line, two methods are available.

First, the idle character can be supplied as normal data; the drawback is that host intervention is required to either fill the FIFO or supply a new DMA buffer periodically while there is no real data to send. The second method is to use the ETC to repeat the required data pattern until transmit data is available. The ETC command functions as shown in Table 17 (COR2[5] is set).

When an 80 hex character is encountered in the transmit data, it and the following three characters are treated as a special command; the format of the bytes is as shown in Table 17.

Table 17. Byte Format - ETC Bit Set

Byte 1	Byte 1 must be equal to 80 hex to start a command sequence.
Byte 2	Byte 2 indicates the required state of the RTS* pin. 00 = the RTS* pin is set inactive (high) 01 = the RTS* pin is set active (low) 02–FF= reserved
Byte 3	Byte 3 is the required character for transmission. It is sent as an 8-bit character without parity (any required parity value should be included by the host).
Byte 4	Byte 4 is the number of times the above character should be sent; if set to '0', the character is sent until new data is supplied — but a minimum of three times.

To idle-in mark with the RTS* line off, the following command could be written '80 00 FF 00'. To send the character '80' while the ETC command is enabled and the RTS* pin is asserted, the following sequence should be written '80 01 80 01'.

7.8.2 Extended X.21 Receive

In Receive mode, the SYN character can be programmed in COR6 to be any required value. When the channel is initialized, COR6 is initially set to the value '16' by the internal code; host software can reprogram this register to the required SYN value after channel initialization has been completed. If a parity mode is enabled, the parity bit should not be set in COR6. Synchronization can be achieved with either a single or double SYN pattern; this is controlled by the SglSyn (single SYN) bit in COR3.

Since the channel does not look for an end of frame delimiter, the host must determine when to end the frame and/or to terminate the buffer (if DMA is used) via software. It also must detect when to start another frame.

Extended-X.21 mode keeps passing received data to host before and/or after it has received the SYN character(s). The host can discard all the junk characters before SYN character(s) whenever the chip detects the SYN character(s) and generates an interrupt.

If the SSDE bit COR3[4] is not set, Extended X.21 mode does not strip SYN characters and special characters from the incoming data stream.

Note: Strip SYN and SCDE are functional only if SSDE is set.

Example 1: (Two Syn mode)

Incoming data:



Note: a SYN character detect interrupt is generated after the second SYN.

Data passed to the host:



Example 2: (Single Syn mode)

Incoming data:



Note: a SYN character detect interrupt is generated after the SYN.

Data passed to the host:



7.9 Programmable Sync

Programmable Sync mode provides a means to enable the CD2481 to be configured for use in many non-standard character or byte synchronous applications. The protocol can be used in data streams that consist of 5, 6, 7 or 8-bit “characters” and can be enabled to synchronize to the data

stream via either one or two user defined SYN characters. Additionally, up to four frame terminating (EOF) characters can be defined. The transmitter may be programmed to idle the transmit data line in either an active high or active low condition; there is no flag fill option in this mode.

7.9.1 Programmable Sync Transmit

The transmitter sends the frame data, shifted out LSB first, with no start or stop bits, no bit-stuffing and no frame check sequence (FCS). This allows maximum flexibility to implement protocols that have non-standard CRC polynomials. If the special protocol being implemented uses an FCS, the host must compute and append the check characters to the frame prior to transmission.

If the character length is less than 8 bits, the CD2481 will strip the unused MSB bits from the character prior to transmission so that the data stream remains true to the character length selected.

Between frames, the CD2481 can 'idle' the TxD pin in either a continuous '1' or '0', depending on the setting of the Idle bit (COR1[7]).

If an underrun condition occurs, either from DMA latency or lack of a buffer (in chained buffer instances) or due to the host failing to respond to a transmit data interrupt in time, the transmitter immediately aborts transmission of the frame and returns the transmit data line to the programmed idle condition.

The host signals the end of frame via either setting the EOF bit in the TEOIR register (interrupt mode) or via the EOF bit in the A/BTBSTS registers (DMA mode).

7.9.2 Programmable Sync Receive

Receive characters are assembled LSB first, with the MSB bits filled with zeroes if the number of bits per character is less than eight.

The receiver initially enters SYN-hunt mode when enabled via the receiver enable command of the CCR. It will shift in data, comparing the value with sync character (SYN1), as specified by the value programmed in COR6. The match is performed on the number of LSB bits programmed for the character length (COR1[3:0]). After character synchronization is achieved via match against SYN1, COR2 is examined to determine if SYN1-SYN2 mode is enabled (COR2[7]). If SYN1-only mode is selected, frame reception commences and, if Strip is enabled (COR2[6]), SYN1 is discarded and not included in the frame data presented to the host, otherwise it is included in the data stream.

If SYN1-SYN2 mode is enabled, the character immediately following SYN1 is compared against the SYN2 value, as programmed in COR7. If a match occurs on SYN2, frame reception begins, with stripping as enabled. If the second character does not match SYN2, the receiver reverts to SYN-hunt mode.

Up to four separate characters may be programmed as frame terminating (EOF) flags. These EOF characters are programmed via the four Special Character Registers (SCHR1-SCHR4). If fewer than four EOF characters are needed, the values in the unused SCHR registers should be programmed with duplicates of the values in use. That is, if only one EOF is needed, all four SCHR registers should be programmed with the same EOF value; if two are needed, SCHR1 and SCHR2 should contain the two characters and SCHR3 and SCHR4 should have duplicates of those values. Once the EOF has been detected, the receiver will automatically re-enter SYN-hunt mode.

Several options are available for handling the EOF character(s). The Append bits (COR3[1:0]) select whether or not the EOF character will be included in the frame data given to the host and, optionally, additional characters following the EOF can also be included.

If Append1 and Append0 are both '0', the EOF is not given to the host. If Append1 is '0' and Append0 is '1', the EOF character is included in the frame data.

Optionally, the first one or two characters following the EOF can also be included in the frame data. If Append1 is '1' and Append0 is '0', the first character following EOF is given to the host; Append1 and Append0 both set to '1' cause the CD2481 to give the host the two characters following EOF.

Note: SYN-hunt for the next frame does not begin until after the programmed number of append characters have been received. Thus, if SYN1 of the next frame immediately follows EOF and Append mode selects that the first character following EOF is to be included in the previous frame data, the device will not sync to the next frame.

Once the EOF has been received, the CD2481 will generate an End-of-Frame interrupt in either interrupt or DMA modes. Any FCS verification must be performed by host software.

7.10 Non-8-Bit Data Transfers

In Asynchronous and programmable sync modes, it is possible to transmit and receive less than 8 bits per character. There can be 5, 6, 7, or 8 bits per character.

For HDLC mode, 8 bits per character are always transmitted. The CD2481 transmits only byte-aligned frames. The CD2481 receives HDLC frames using transfers of 8 bits per character, except for the last character received before the FCS. If this last character is not aligned to an 8-bit boundary, the ResInd (residual indication) bit is set along with the EOF bit in RISR1. The residual character is zero filled and LSB aligned in the FIFO.

8.0 Programming Examples

This section provides some examples of CD2481 programming. Included are examples of Global and Per-Channel initialization, and two interrupt service routines. The code was written in Borland® Turbo C++.



Figure 20. Initialization Sequence for the CD2481

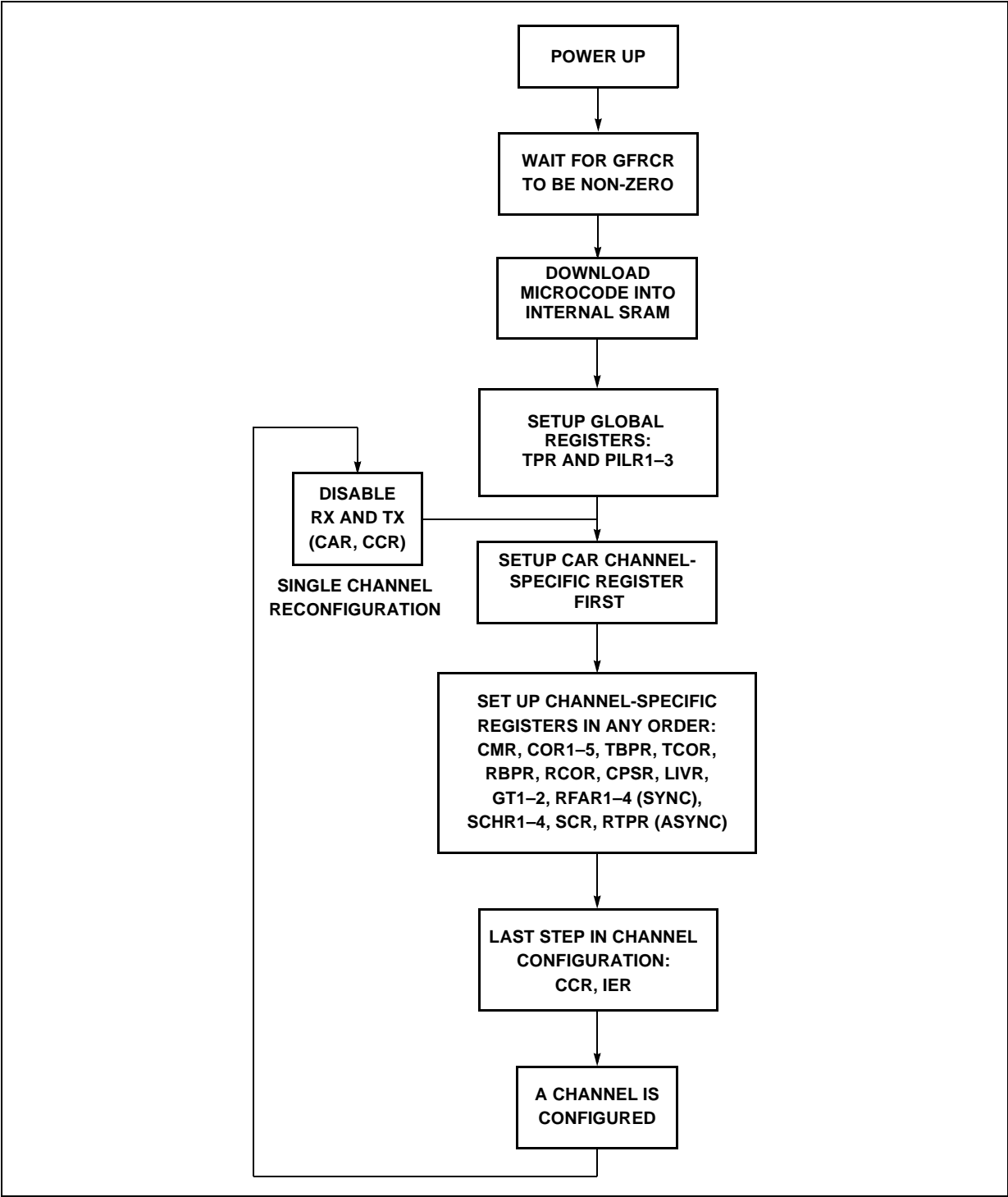

8.1 Global Initialization

The following is an example of global initialization. The host waits for a hardware reset, determined by a non-zero value in the GFRCR (Global Firmware Revision Code register). After the GFRCR becomes non-zero, the host must download the microcode image into the internal SRAM (see chapter 5 for details of the download operation. After the download, a ‘Reset All’ command can be sent to the CD2481 by the CCR (Channel Command register). The internal CPU puts a non-zero value into GFRCR when initialization is complete.

The PILRs (Priority Interrupt Level registers) should be loaded with the value of the seven address lines A[6:0] during interrupt acknowledge cycles. The TPR (Timer Prescale register) loads the dividing counter that inputs each of the other timers in the CD2481. The DMA Mode and Bus Error Count registers are used in DMA modes only. After the Global portion is done, the Per-Channel registers need to be initialized. Transfers and interrupts should be enabled after all other initialization is complete.

```
// Global Initialization

while( !inportb( GFRCR ) )// wait for hardware reset
    ; // wait

outportb( CCR, RESET_ALL ) ;// Reset command

while( !inportb( GFRCR ) ) // wait for reset command
    ; // wait

outportb( PILR1, 0x02 );// Priority Interrupt
outportb( PILR2, 0x04 );// Level registers
outportb( PILR3, 0x06 );
outportb( TPR, 0x40 );// Set timer prescale
outportb( BERCNT, 0 );// Bus error count
outportb( DMR, 0 );// DMA mode – 16-bit

// per-channel initialization

for( i=0; i<4; i++ ) {
    outportb( CAR, i );// set channel number
    init_chan( cor, bpr );// initialize channel
    outportb( CCR, INIT_CH | EN_RX | EN_TX );
```

```
while( inportb(CCR) )  
    ; // wait  
outportb( IER, TX_DATA|RX_DATA );// enable interrupts  
}
```

8.2 Async Interrupt Setup Example

This section shows an example for an asynchronous channel running at 19,200 bits per second, with 8 bits/character, 1 Stop bit, and no parity. The sample program enables in-band flow control and implied XON mode. This code assumes that the proper channel has been set by the CAR (Channel Access register).

```
outportb( LIVR, 0x40 );

outportb( RCOR, 0 );// Receive clock option

outportb( RBPR, 0x81 );// Baud Rate divisor

outportb( TCOR, 0 );// Transmit clock option

outportb( TBPR, 0x81 );// Baud Rate divisor

outportb( CMR, ASYNC );// Async Mode, interrupt

outportb( COR1, PARIGN | CHAR8 );// 8 bit chars, no parity
outportb( COR2, IXM | TXIBE );// in-band flow, implied XON
outportb( COR3, STOP1 | FCT );// 1 stop, flow control
outportb( COR4, thresh );// FIFO threshold
outportb( COR5, 0 );
```

8.3 HDLC DMA Channel Setup Example

This per-channel initialization example is for the HDLC protocol at 38.4 kbps with NRZI encoding. The setup specifies two extra opening flags before frames, no address matching, and that DMA transfers should be used.

```
outportb( LIVR, 0x30 );// Set interrupt vector

outportb( RCOR, DPLL_NRZI );// Receive clock option
outportb( RBPR, 64 );// Baud rate divisor
outportb( TCOR, 0 );// Transmit clock option
outportb( TBPR, 64 );// Baud rate divisor

outportb( CMR, RX_DMA | TX_DMA | HDLC );// Mode register
outportb( CPSR, CPSR_CRC_V41 );// CRC polynomial select
```

```
outportb( COR1, NO_ADDR | FLAG_2 );// No address matching,  
outportb( COR2, CRC_V41 );// 2 opening flags  
outportb( COR3, 0 );  
outportb( COR4, thresh );// FIFO threshold  
outportb( COR5, 0 );
```

8.4 Receive DMA Interrupt Service Routine

The following example shows an interrupt service routine for the CD2481 in DMA mode. The buffer class array 'ib[]' is used for notational convenience, and its exact implementation is user-defined. The upper () and lower () functions should return the upper and lower 16 bits of the DMA address for the current buffer segment. The next_buf() accesses the next segment.

If the system uses separate interrupt handlers for receive, transmit, and modem interrupts, the channel number can be obtained from the lower 2 bits of the Interrupt register (RIR/TIR/MIR). Otherwise, use LIVR first to determine the type of interrupt. Receive 'Good Data' interrupts should not occur during DMA transfers. The normal exception is when end of frame is received.

DMABSTS shows which buffer the CD2481 expects to use next. Fill the descriptor registers for that buffer, including the 2481OWN bit and return. The last access to the CD2481 during the service routine is the REOIR.

```
int risrl = inportb( RISRL );// low status
int ch = inportb( RIR ) & 0x03;// channel number
switch( inport( LIVR ) & 0x03 ) {
case LIVR_GOODDATA:// shouldn't happen in DMA
    break;
case LIVR_EXCEPTION:// EOF is 'normal' exception
    if( risrl & RISR_EOF ) {
        if( inportb( DMABSTS ) & DMABS_NRBUF ) { // buffer B next
            outport( BRBADRU, ib[ch].upper() );
            outport( BRBADRL, ib[ch].lower() );
            outport( BRBCNT, BUF_MAX );
            outport( BRBSTS, OWN_2481 );
            ib[ch].next_buf();// get next buffer
        } else { // buffer A next
            outport( ARBADRU, ib[ch].upper() );
            outport( ARBADRL, ib[ch].lower() );
            outport( ARBCNT, BUF_MAX );
            outport( ARBSTS, OWN_2481 );
            ib[ch].next_buf();// get next buffer
        }
    }
}
outportb( REOIR, ZERO );
```

8.5 Transmit Interrupt Service Routine

The following example is a transmit interrupt service handler example. When using a synchronous protocol, transmitters must declare an end of frame if an underrun occurs. If the end of buffer is encountered before data is transferred by this interrupt service, then the NOTRANS bit in TEOIR should be set along with EOF. TEOIR is always the last access of an interrupt service routine.

```

int teoir = ZERO; // default

int tizr = inportb( TISR ); // status

int ch = inportb( TIR ) & 0x03; // channel number

switch( tizr ) {

case TISR_UE:

    teoir = TEOIR_EOF; // underflow

    break;

case TISR_TXDATA:

    tftc = inportb( TFTC ); // FIFO count

    for( i=0; i<tftc; i++) {

        if( ob[ch].is_eob() ) { // end of buffer ?

            ob[ch].nxt_buf(); // get next buffer

            teoir = TEOIR_EOF;

            if( i==0 )

                teoir |= NOTRANS;

            break;

        }

        else outportb( TDR, ob[ch].nxt_char() ); // send next character

    }

}

outportb( TEOIR, teoir );

```

8.6 Support Files from the Intel FTP Server

For additional programming examples, sample register definition and symbol header files (for C++), connect to the Basis Communications ftp server and download the files in the datacom support area:

<ftp://ftp.basiscomm.com/pub/oem/sio/cd2481/evalbdv2>



Programmable Four-Channel Communications Controller — CD2481

For the latest microcode image, connect to the Basis Communications ftp server and download the file in the CD2481 firmware support area:

`ftp://ftp.basiscomm.com/pub/oem/sio/cd2481/Firmware`

9.0 Detailed Register Descriptions

9.1 Global Registers

9.1.1 Global Firmware Revision Code Register (GFRCR)

Register Name: GFRCR						Intel Hex Address: x'82	
Register Description: Global Firmware Revision Code Register						Motorola Hex Address: x'81	
Default Value: x'0D							
Access: Byte Read/Write							
Bit 7	Bit 6	Bit 5	Bit 4	Bit 3	Bit 2	Bit 1	Bit 0
Firmware Revision Code							

This register serves two functions in providing the host with information about the CD2481. When the CD2481 is initialized by a hardware RESET signal, or by a software 'Reset All' command issued through any Channel Command register, the CD2481 zeros this register at the start of the initialization. At the conclusion of the initialization, the CD2481 writes firmware revision code to the GFRCR. All valid CD2481 revision codes are non-zero, the revision code is incremented by one with each new release, for example, GFRCR for Revision A = DD hex, Revision B is DE hex, Revision D is E0 hex.

Host software must confirm that the GFRCR contents are non-zero before proceeding to configure the CD2481 for normal operation.

9.1.2 Channel Access Register (CAR)

Register Name: CAR						Intel Hex Address: x'EC	
Register Description: Channel Access Register						Motorola Hex Address: x'EE	
Default Value: x'03							
Access: Byte Read/Write							
Bit 7	Bit 6	Bit 5	Bit 4	Bit 3	Bit 2	Bit 1	Bit 0
Reserved						C1	C0

This register contains the channel number for the channel-oriented host read or write operations, when the host is not in an interrupt service routine. The CD2481 supplies the interrupting channel number during all interrupt service operations. The Channel Access register contents are not used during an interrupt service. Note that this means that an interrupt service routine is restricted to accessing only the register set of the Interrupting Channel and Global registers.

Bits 7:2 Reserved – *must be zero*.

Bits 1:0 Channel number

C1		C0	Channel number
0		0	Channel 0
0		1	Channel 1
1		0	Channel 2
1		1	Channel 3

9.2 Option Registers

9.2.1 Channel Mode Register (CMR)

Register Name: CMR				Intel Hex Address: x'18			
Register Description: Channel Mode Register				Motorola Hex Address: x'1B			
Default Value: x'02							
Access: Byte Read/Write							
Bit 7	Bit 6	Bit 5	Bit 4	Bit 3	Bit 2	Bit 1	Bit 0
RxMode	TxMode	0	0	chmd3	chmd2	chmd1	chmd0

Bit 7 Receive Transfer mode
0 – Interrupt
1 – DMA

Bit 6 Transmit Transfer mode
0 – Interrupt
1 – DMA

Bits 5:3 Reserved – *must be zero.*

Bits 2:0 Protocol mode select
If these options are changed, an initialize command must be given to the CD2481 through the Channel Command register.

chmd3	chmd2	chmd1	chmd0	Protocol
0	0	0	0	HDLC
0	0	0	1	Bisync
0	0	1	0	Async
0	0	1	1	X.21
0	1	0	0	Async-HDLC/PPP
0	1	0	1	SLIP

chmd3	chmd2	chmd1	chmd0	Protocol
0	1	1	0	MNP4/ARAP
0	1	1	1	Reserved
1	0	0	0	Programmable Sync

9.2.2 Channel Option Register 1 (COR1)

COR1 – HDLC Mode (Not used in PPP mode)

Register Name: COR1				Intel Hex Address: x'13			
Register Description: Channel Option Register 1				Motorola Hex Address: x'10			
Default Value: x'00							
Access: Byte Read/Write							
Bit 7	Bit 6	Bit 5	Bit 4	Bit 3	Bit 2	Bit 1	Bit 0
AFLO	ClrDet	AdMd1	AdMd0	Flag3	Flag2	Flag1	Flag0

If any options specified in this register are changed, an initialize command must be given to CD2481 through the Channel Command register.

Bit 7 Address field length option
 0 = Address field is 1 octet in length
 1 = Address field is 2 octets in length

Bit 6 Clear detect for X.21 data transfer phase
 0 = Clear detect disabled
 1 = Clear detect enabled
 A clear is defined as two consecutive all zero receive characters with the CTS* pin high.

Bits 5:4 Addressing modes
 00 = no address recognition
 01 = 4 * 1 byte
 10 = 2 * 2 byte
 If this bit is set, RFAR1, RFAR2, RFAR3, and RFAR4 should contain the address to be matched. If AFLO is set to '1', an address match is made against the RFAR1 and RFAR2 pair or the RFAR3 and RFAR4 pair.

Bits 3:0 Inter-frame flag option
 Defines the minimum number of flags transmitted before a frame is started.

Flag 3	Flag 2	Flag 1	Flag 0	
0	0	0	0	minimum of 1 opening flag, with shared closing/opening flags permitted
0	0	0	1	
through				minimum number of opening flags sent
1	1	1	1	

The minimum number of opening flags always precede a frame when idle in Mark mode is set, or is always separated by two consecutively transmitted frames. No restriction is placed on the number of flags between received frames.

Note: Not used in PPP, MNP4, and SLIP modes.

COR1 – Asynchronous, Bisynchronous, and X.21 Modes (Not used in PPP mode)

Register Name: COR1				Intel Hex Address: x'13			
Register Description: Channel Option Register 1				Motorola Hex Address: x'10			
Default Value: x'00							
Access: Byte Read/Write							
Bit 7	Bit 6	Bit 5	Bit 4	Bit 3	Bit 2	Bit 1	Bit 0
Parity	ParM1	ParM0	Ignore	ChL3	ChL2	ChL1	ChL0

Bit 7 Parity
1 = odd parity
0 = even parity

Bits 6:5 Parity mode 1 and 0
Defines Parity mode for both transmitter and receiver:

ParM1	ParM0	Parity
0	0	no parity
0	1	force parity
		(odd parity = force 1, even = force 0)
1	0	normal parity
1	1	reserved

Bit 4 Ignore – Ignore parity
0 = evaluate parity on received characters
1 = do not evaluate parity on received characters

Bits 3:0 Character Length

ChL3	ChL2	ChL1	ChL0	Character Length
0	1	0	0	5 bits
0	1	0	1	6 bits
0	1	1	0	7 bits
0	1	1	1	8 bits

Note: Not used in PPP, MNP4, and SLIP modes.

COR1 – Programmable Sync Mode (Not used in PPP mode)

Register Name: COR1						Intel Hex Address: x'13	
Register Description: Channel Option Register 1						Motorola Hex Address: x'10	
Default Value: x'00							
Access: Byte Read/Write							
<i>Bit 7</i>	<i>Bit 6</i>	<i>Bit 5</i>	<i>Bit 4</i>	<i>Bit 3</i>	<i>Bit 2</i>	<i>Bit 1</i>	<i>Bit 0</i>
Idle	0	0	0	ChL3	ChL2	ChL1	ChL0

Bit 7 Idle–Transmit pin idle state
This bit selects the level at which the TxD pin will be held when no frame transmission is in progress.
0 = Idle with TxD 'low', Idle in 0's
1 = Idle with TxD 'high', Idle in 1's

Bits 6:4 Reserved - *must be zero*.

Bits 3:0 Character Length

ChL3	ChL2	ChL1	ChL0	Character Length
0	1	0	0	5 bits
0	1	0	1	6 bits
0	1	1	0	7 bits
0	1	1	1	8 bits
1	0	0	0	Reserved
:	:	:	:	:
1	1	1	1	Reserved

Note: Not used in PPP, MNP4, and SLIP modes.

9.2.3 Channel Option Register 2 (COR2)

COR2 – HDLC Mode

Register Name: COR2						Intel Hex Address: x'14	
Register Description: Channel Option Register 2						Motorola Hex Address: x'17	
Default Value: x'00							
Access: Byte Read/Write							
<i>Bit 7</i>	<i>Bit 6</i>	<i>Bit 5</i>	<i>Bit 4</i>	<i>Bit 3</i>	<i>Bit 2</i>	<i>Bit 1</i>	<i>Bit 0</i>
0	FCSApd	0	CRCNinv	0	RtsAO	CtsAE	DsrAE

Bit 7 Reserved – *must be zero*.



- Bit 6 FCS append
0 = Receive CRC is not passed to the host at end of frame
1 = Receive CRC is passed to the host at end of frame
- Bit 5 Reserved – *must be zero.*
- Bit 4 CRCNinv
0 = CRC is transmitted inverted (that is, CRC V.41)
1 = CRC is not transmitted inverted (that is, CRC-16)
- Bit 3 Reserved – *must be zero.*
- Bit 2 RTS automatic output enable
When set, if the channel is enabled, the CD2481 automatically asserts the RTS* output when it has characters to send. When Idle-in Mark mode is selected, RTS* is asserted prior to opening flags and remains asserted until after a closing flag has been transmitted.
- Bit 1 CTS automatic enable
Enables CTS* input to be used as automatic transmitter enable/disable. If enabled, the CTS input is checked before frame transmission is started.
- Bit 0 DSR Automatic Enable
Enable the DSR* input as automatic receiver enable/disable. If enabled, the pin is checked at the beginning of each received frame.

COR2 – Bisynchronous Mode

Register Name: COR2						Intel Hex Address: x'14	
Register Description: Channel Option Register 2						Motorola Hex Address: x'17	
Default Value: x'00							
Access: Byte Read/Write							
Bit 7	Bit 6	Bit 5	Bit 4	Bit 3	Bit 2	Bit 1	Bit 0
LRC	BCC	EBCDIC	CRCNinv	NoStrip	Alt-Ctrl	SYN1	SYN0

- Bit 7 Longitudinal redundancy check
0 = CRC16 used for BCC
1 = LRC used for BCC
- Bit 6 BCC Append
0 = Receive BCC is not passed to the host at end of frame.
1 = Receive BCC is passed to the host at end of frame.
- Bit 5 EBCDIC
0 = ASCII character set in use.
1 = EBCDIC character set in use.
- Bit 4 CRCNinv
0 = CRC is transmitted inverted (CRC V.41).
1 = CRC is not transmitted inverted (CRC-16).



Bit 3 **NoStrip**
 0 = NoStrip disabled; stripping of DLE-SYN or SYN-SYN will occur.
 1 = NoStrip enabled; if this bit is set, stripping of DLE-SYN (transparent frames) or SYN-SYN (non-transparent frames) is disabled. DLE-SYN or SYN-SYN will be kept in the frame data.

Bit 2 **Alternate Control**
 Alt-Ctrl has significance only if COR2 bit 7 (LRC) is 0 (which selects CRC-16), and COR2 bit 5 is 1, which allows the 7 bit ASCII data in 8 bit EBCDIC format. The eighth bit is for error-checking, while for transparent case, the host should use CRC-16 for error checking. In all cases the CD2481 would use CRC-16 calculation and checking. The burden of checking character validity (through VRC or CRC-16 during reception) along with 8th bit parity addition (during transmission) is to be borne by host alone.

Note: As a side effect, the CRC error bit (set by CD2481) may not be valid for the host. It may be ignored in case of non-transparent text and may be used in case of transparent text.

Bits 1:0 **Extra SYN characters**
 This field determines the number of extra synchronize (SYN) characters that are transmitted before a frame is started. The two required SYNs are not included in this count. This is a binary encode field in which the two required SYNs are followed by the encoded number of characters (00 = no extra characters; 11 = 3 extra characters)

Note: In ASCII mode, data is 7 bit with LRC (odd parity) checking only. In EBCDIC mode, data is 8 bit with CRC checking only. See exception under Alternate Control Bit (COR2 bit 2).

COR2 – Asynchronous

Register Name: COR2				Intel Hex Address: x'14			
Register Description: Channel Option Register 2				Motorola Hex Address: x'17			
Default Value: x'00							
Access: Byte Read/Write							
Bit 7	Bit 6	Bit 5	Bit 4	Bit 3	Bit 2	Bit 1	Bit 0
IXM	TxIBE	ETC	0	RLM	RtsAO	CtsAE	DsrAE

Bit 7 **IXM – Implied XON mode**
 IXM has meaning only when TxIBE is set.
 If transmission has been stopped due to a received XOFF character, then:

 If IXM = 0, then transmission is resumed only after the receipt of an XON character or a transmit enable command by the Channel Command register (CCR).

 If IXM = 1, then transmission is resumed after the receipt of any character or a transmit enable command by the CCR.

Bit 6 **TxIBE – Transmit in-band flow control enable**
 If TxIBE is clear, there is no in-band flow control.

If TxIBE is set, then transmission is stopped after the receipt of an XOFF character (cntl-S or hex 13). Immediately after receiving an XOFF, any character in the Transmit Shift register or Holding Register is transmitted, and character transmission is halted. Thus, no more than two characters are sent after receiving an XOFF.

Depending on the IXM bit, either the receipt of an XON (cntl-Q or hex 11) character or any character (IXM = 1) restarts the transmission. A transmit enable command by the CCR also restarts transmission.

- Bit 5 Embedded transmitter command enable (Async)
 If set, the embedded special transmitter command functions are enabled. The null (all zeroes) character is used as the ESCape character. The following functions are supported:
- 00H 00H – Send one 00H character as normal data
 - 00H 81H – Send break
 Enter line break condition for at least 1 character time. (If the insert delay special character sequence immediately follows the send break sequence, the duration of the break transmission is extended by the amount of the programmed delay.)
 - 00H 82H XXH – Insert delay
 Insert a delay of ‘XX’ (interpreted as an unsigned binary number) times the programmed timer ‘tick’ set by the Prescaler Period registers. (A zero delay count results in no delay.)
 - 00H 83H – Stop break
 Exit line break condition and resume normal character transmission.
- Bit 4 Reserved – *must be zero*.
- Bit 3 RLM – Remote loop back
 RLM = 1 enables Remote Loopback mode.
 RLM = 0 disables Remote Loopback mode.
- Bit 2 RtsAO – RTS automatic output enable
 If RtsAO = 1, the RTS* output pin remains enabled during DMA or character bursts from the transmit FIFO. If the CTS* input pin goes high, then RTS* goes high and transmission is stopped after the current burst is completed.
- Bit 1 CtsAE – CTS automatic enable
 When clear, the transmitter output enable is independent of the CTS* input pin.

 When set, the CTS* input pin is evaluated prior to the transmission of each character. If CTS* is asserted low, that character is transmitted completely. If CTS* is high, that character transmission is held until CTS* goes low.
- Bit 0 DsrAE – DSR automatic enable
 When clear, the receiver input enable is independent of the DSR* input pin.

 When set, the DSR* input pin is evaluated at the end of each received character. If DSR* is asserted low, the receiver input is enabled for the next character. If DSR* is high, the receiver is disabled until DSR* goes low.

COR2 – X.21 Mode

Register Name: COR2 Register Description: Channel Option Register 2 Default Value: x'00 Access: Byte Read/Write						Intel Hex Address: x'14 Motorola Hex Address: x'17	
Bit 7	Bit 6	Bit 5	Bit 4	Bit 3	Bit 2	Bit 1	Bit 0
0	0	ETC	0	0	0	0	0

Bits 7:6 Reserved – *must be zero*.

Bit 5 Embedded transmitter command enable
If set, embedded command in the FIFO is detected and acted upon.

Bit 4:0 Reserved – *must be zero*.

FIFO Data Sequence to Implement the Embedded Transmit Command

In X.21 mode, this feature is provided to simplify the transmission of both repetitive data and data synchronized to the 'C' lead. The command is a sequence of four consecutive bytes supplied as normal transmit data by the host processor. The sequence of bytes placed in the data stream to implement this are:

Byte1 This must be equal to 80 hex to start a command sequence.

Byte 2 This byte indicates the required state of the 'C' lead to be synchronized with the transmit data.
00 = set the 'C' lead to OFF
01 = set the 'C' lead to ON
02–FF = reserved, do not use

Byte 3 This is the required data character for transmission. It is sent as an 8-bit character without parity (any required parity should be included in the character by the host).

Byte 4 This is the count of the number of times the character should be sent. If set to '0', the character is sent continuously until more data is provided to the transmitter (but always a minimum of three times).

COR2 – Async-HDLC / PPP Mode

Register Name: COR2 Register Description: Channel Option Register 2 Default Value: x'00 Access: Byte Read/Write						Intel Hex Address: x'14 Motorola Hex Address: x'17	
Bit 7	Bit 6	Bit 5	Bit 4	Bit 3	Bit 2	Bit 1	Bit 0
IXM	TxIBE	0	0	RLM	RtsAO	CtsAE	DsrAE

Bit 7	<p>IXM – Implied XON mode IXM has meaning only when TxIBE is set. If transmission has been stopped due to a received XOFF character, and:</p> <p>If IXM = 0, transmission is resumed only after the receipt of an XON character or a transmit enable command by the CCR (Channel Command register).</p> <p>If IXM = 1, transmission is resumed after the receipt of any character or a transmit enable command by the CCR.</p>
Bit 6	<p>TxIBE – Transmit in-band flow control enable If TxIBE is clear, there is no in-band flow control.</p> <p>If TxIBE is set, transmission is stopped after the receipt of an XOFF character (cntl-S or hex 13). Immediately after receiving an XOFF, any character in the Transmit Shift register or Holding register is transmitted, and then character transmission is halted. Thus, no more than two characters are sent after receiving an XOFF.</p> <p>Depending on the IXM bit, either the receipt of an XON (cntl-Q or hex 11) character or any other character (IXM = 1) restarts the transmission. A transmit enable command by the CCR also restarts the transmission.</p>
Bits 5:4	Reserved – <i>must be zero.</i>
Bit 3	<p>RLM – Remote loop back RLM = 1, enables Remote Loopback mode RLM = 0, disables Remote Loopback mode</p>
Bit 2	<p>RtsAO – RTS automatic output enable If RtsAO = 1, the RTS* output pin remains enabled during DMA or character bursts from the transmit FIFO. If the CTS* input pin goes high, RTS* goes high and transmission is stopped after the current burst is completed.</p>
Bit 1	<p>CtsAE – CTS automatic enable When clear, the transmitter output enable is independent of the CTS* input pin.</p> <p>When set, the CTS* input pin is evaluated prior to the transmission of each character. If CTS* is asserted low, that character is transmitted completely. If CTS* is high, that character transmission is held until CTS* goes low.</p>
Bit 0	<p>DsrAE – DSR automatic enable When clear, the receiver input enable is independent of the DSR* input pin.</p> <p>When set, the DSR* input pin is evaluated at the end of each received character. If DSR* is asserted low, the receiver input is enabled for the next character. If DSR* is high, the receiver is disabled until DSR* goes low.</p>

COR2 – MNP4/SLIP Mode

Register Name: COR2					Intel Hex Address: x'14		
Register Description: Channel Option Register 2					Motorola Hex Address: x'17		
Default Value: x'00							
Access: Byte Read/Write							
Bit 7	Bit 6	Bit 5	Bit 4	Bit 3	Bit 2	Bit 1	Bit 0
0	0	0	0	RLM	RtsAO	CtsAE	DsrAE

Note: SLIP, MNP4, and Automatic In-Band Flow Control modes are only available on Revision B and later devices.

Bits 7:6 Reserved – *must be zero*. No in-band flow control in MNP4 mode.

Bits 5:4 Reserved – *must be zero*.

Bit 3 RLM – Remote Loop Back mode
RLM = 1 enables Remote Loopback mode
RLM = 0 disables Remote Loopback mode

Bit 2 RtsAO – RTS automatic output enable
If RtsAO = 1, then the RTS* output pin remains enabled during DMA or character bursts from the transmit FIFO. If the CTS* input pin goes high, then RTS* goes high and transmission is stopped after the current burst is completed.

Bit 1 CtsAE – CTS automatic enable
When clear, the transmitter output enable is independent of the CTS* input pin.

When set, the CTS* input pin is evaluated prior to the transmission of each character. If CTS* is asserted low, that character is transmitted completely. If CTS* is high, that character transmission is held until CTS* goes low.

Bit 0 DsrAE – DSR automatic enable
When clear, the receiver input enable is independent of the DSR* input pin.
When set, the DSR* input pin is evaluated at the end of each received character. If DSR* is asserted low, the receiver input is enabled for the next character. If DSR* is high, the receiver is disabled until DSR* goes low.

COR2 – Programmable Sync Mode

Register Name: COR2					Intel Hex Address: x'14		
Register Description: Channel Option Register 2					Motorola Hex Address: x'17		
Default Value: x'00							
Access: Byte Read/Write							
Bit 7	Bit 6	Bit 5	Bit 4	Bit 3	Bit 2	Bit 1	Bit 0
SYN2	Strip	0	0	0	RtsAO	CtsAE	DsrAE

Bit 7	<p>SYN characters Selects one or two character match for character synchronization to start frame reception. 0 = SYN1 only (COR6) 1 = SYN1 and SYN2 (COR6 and COR7)</p>
Bit 6	<p>Strip 0 = Do not strip SYN characters from data stream (SYN characters are passed to the host). 1 = Strip SYN characters from data stream (not passed to the host).</p>
Bit 5:3	Reserved— <i>must be zero</i> .
Bit 2	<p>RtsAO – RTS automatic output enable If RtsAO = 1, the RTS* output pin remains active during frame transmission.</p>
Bit 1	<p>CtsAE – CTS automatic enable When clear, the transmitter output enable is independent of the CTS* input pin.</p> <p>When set, the CTS* input pin is evaluated prior to frame transmission. If CTS* is asserted low, the frame is transmitted completely. If CTS* is high, frame transmission is held until CTS* goes low. If CTS* changes after frame transmission begins, the frame will be transmitted to completion, after which CTS* will once again be evaluated.</p>
Bit 0	<p>DsrAE – DSR automatic enable When clear, the receiver input enable is independent of the DSR* input pin. When set, the receiver is enabled only when the DSR* input pin is asserted low. If DSR* is high, the receiver is disabled until DSR* goes low.</p>

9.2.4 Channel Option Register 3 (COR3)

COR3 – HDLC Mode

Register Name: COR3 Register Description: Channel Option Register 3 Default Value: x'00 Access: Byte Read/Write						Intel Hex Address: x'15 Motorola Hex Address: x'16	
Bit 7	Bit 6	Bit 5	Bit 4	Bit 3	Bit 2	Bit 1	Bit 0
sndpad	Alt1	FCSPre	FCS	idle	npad2	npad1	npad0

In Synchronous mode, COR3 is used to specify the learning pattern (pad character) sent by the CD2481 to synchronize the DPLL at the remote end. The pad character (00h or AAh) sent depends on the kind of encoding used.

Bit 7	<p>Sends pad character(s) 1 = CD2481 sends pad character(s) before sending flag when coming out of the Mark Idling mode. 0 = CD2481 does not send any pad character.</p>
-------	--



- Bit 6 alt1 – send sync pattern
1 = AAh (Manchester/NRZ encoding) is sent as pad character.
0 = 00h (NRZI encoding) is sent as pad character.

- Bit 5 FCS preset
0 = FCS is preset to all ‘1’s (CRC V.41).
1 = FCS is preset to all ‘0’s (CRC-16).

- Bit 4 FCS mode
1 = Disables FCS generation and checking. The CD2481 treats the entire frame as data.
0 = Normal FCS mode. The CD2481 generates and appends CRC on transmit and validates CRC on receive using the CRC polynomial selected through the CRC Polynomial Select register.

- Bit 3 Idle mode
0 = idle in Flag mode
1 = idle in Mark mode

- Bits 2:0 Character Count – specifies the number of synchronous characters sent.

npad2	npad1	npad0	
0	0	0	Reserved
0	0	1	1 pad character sent
0	1	0	2 pad characters sent
0	1	1	3 pad characters sent
1	0	0	4 pad characters sent
101–111 are reserved.			

COR3 – Bisynchronous Mode

Register Name: COR3 Register Description: Channel Option Register 3 Default Value: x'00 Access: Byte Read/Write						Intel Hex Address: x'15 Motorola Hex Address: x'16	
Bit 7	Bit 6	Bit 5	Bit 4	Bit 3	Bit 2	Bit 1	Bit 0
Sndpad	S55	FCSPre	FCS	Idle	DisCRC	npad1	npad0

- Bit 7 Send pad character
0 = CD2481 does not send any pad characters.
1 = CD2481 sends pad characters before sending SYN when coming out of the Mark Idle mode.

- Bit 6 S55 = Send pad pattern
0 = hex AA is sent as pad character.
1 = hex 55 is sent as pad character.



- Bit 5 FCS preset
0 = FCS is preset to all '0's.
1 = FCS is preset to all '1's.

- Bit 4 FCS mode
0 = Normal FCS mode. The CD2481 generates and appends CRC on transmit and validates CRC on receiving, using the CRC polynomial selected through CRC Polynomial Select register.
1 = Disable FCS generation and checking. The CD2481 treats the entire frame as data.

- Bit 3 Idle mode
0 = Idle in SYN.
1 = Idle in Mark.

- Bit 2 Disable CRC transmission on all Bisync frames
0 = disable function
1 = CRC will not be transmitted on any frames

- Bits 1:0 Pad count – Transmit frame leading pads
Specifies the number of pad characters to be sent when coming out of Mark Idle mode.

npad1	npad0	Number of leading pads
0	0	0
0	1	1
1	0	2
1	1	3

COR3 – Asynchronous Mode

Register Name: COR3 Register Description: Channel Option Register 3 Default Value: x'00 Access: Byte Read/Write						Intel Hex Address: x'15 Motorola Hex Address: x'16	
Bit 7	Bit 6	Bit 5	Bit 4	Bit 3	Bit 2	Bit 1	Bit 0
ESCDE	RngDE	FCT	SCDE	Splstp	Stop2	Stop1	Stop0

- Bit 7 ESCDE – Extended special character detect enable
0 = Special character detect for SCHR3 and SCHR4 is disabled.
1 = Special character detect for SCHR3 and SCHR4 is enabled; a special character interrupt is generated following the receipt of a character matching SCHR3 or SCHR4.

- Bit 6 RngDE – Range detect enable
0 = Range detect disabled.



1 = Characters between SCRI and SCRh (inclusive) generate special character interrupts.

Bit 5 FCT – Flow Control Transparency mode
 0 = Flow control characters received are passed to the host by receive exception interrupts.
 1 = Flow control characters received are not passed to the host.
 This bit has no effect unless both TxIBE (COR2) and SCDE (COR3) are set.

Bit 4 SCDE – Special character detection
 0 = Special character detect for SCHR1 and 2 is disabled.
 1 = Special character detect for SCHR1 and 2 is enabled.

 This bit must be set along with TxIBE (COR2) before FCT (COR3) becomes effective.

Bit 3 Splstp – Special character I-strip
 When set, this bit causes the receive character to be I-stripped (bit 7 set to '0') for the special character matching functions only. The character passed to the host is unaffected. This function allows special character processing of data without knowing if the data is 8 bit with no parity or 7 bit with parity.

Bits 2:0 Stop2, Stop1, Stop0 – Stop bit length
 Specifies the length of the Stop bit.

Stop2	Stop1	Stop0	Stop Bit Length
0	1	0	1 stop bit
0	1	1	1.5 stop bits
1	0	0	2 stop bits
000–001 and 110–111 are reserved.			

COR3 – X.21 Mode

Register Name: COR3 Register Description: Channel Option Register 3 Default Value: x'00 Access: Byte Read/Write						Intel Hex Address: x'15 Motorola Hex Address: x'16	
Bit 7	Bit 6	Bit 5	Bit 4	Bit 3	Bit 2	Bit 1	Bit 0
SglSyn	SSDE	StrpSyn	SCDE	0	0	0	0

Bit 7 Single SYN
 This bit determines the number of SYN characters that need to be received before Character Synchronization mode is considered received.
 0 = Two SYN characters are required.
 1 = One SYN character is required.

Note: The SglSyn option is only available for Extended X.21 Mode; standard X.21 mode always requires two SYN characters. When the SglSyn option is set, StrpSyn and SCDE options are disabled.



Bit 6 Steady state detect enable
 When set, this bit enables the checking of special receive conditions relevant to X.21. The conditions are:
 1. All '0's
 2. All '1's
 3. Alternating '0's and '1's.
 4. Change in the condition of the CTS* pin (CTS* is used as the 'I' lead for DTE or 'C' lead for DCE).

To be detected as a special condition, a change must be present for at least 16 bit times. When detected, a receive exception interrupt is generated with the relevant status set in the RISR. After detection of the special condition, no further data is passed to the host until different data is received.

In certain phases of X.21 call setup, there is no character synchronization. When a data change occurs in a non-character synchronous phase, a partial character can be detected before the steady state is detected or character sync is achieved. In these conditions, the partial character is passed to the host as normal data.

Bit 5 Strip SYN
 When this bit is set, SYN characters are treated as special receive conditions; when two SYN characters are received, a special character interrupt is generated (see RISR), and following SYN characters are stripped from the incoming data stream. If this bit is not set, the SYN characters are treated as normal data and passed to the host in Good Data interrupts; they are still used to obtain character synchronization with the data.

Bit 4 Special character detect enable
 SCDE is only available when SSDE mode (see above) is enabled. If enabled, the characters programmed in SCHR[1–3] are treated as the steady state conditions in the SSDE mode. They are validated for two character times, a special character interrupt is generated and subsequent repetitions of the same data pattern are filtered from the data stream.

Bits 3:0 Reserved – *must* be zero; will read back as zero.

COR3 – Async-HDLC/PPP Mode

Register Name: COR3				Intel Hex Address: x'15			
Register Description: Channel Option Register 3				Motorola Hex Address: x'16			
Default Value: x'00							
Access: Byte Read/Write							
Bit 7	Bit 6	Bit 5	Bit 4	Bit 3	Bit 2	Bit 1	Bit 0
Stop2	0	RxChk	TxGen	npad3	npad2	npad1	npad0

Bit 7 Stop2
 0 = 1 Stop bit
 1 = 2 Stop bit

Bit 6 Reserved – *must be zero*.



- Bit 5 RxChk – Receive FCS check enabled
When clear, the channel does not test the 2-byte FCS field. All frame data characters are given to the host.
When set, the channel tests the 2-byte FCS field.
- Bit 4 TxGen – Transmit FCS enabled
When clear, the channel does not add the 2-byte FCS field.
When set, the channel adds the 2-byte FCS field at the end of the frame.
- Bits 3:0 npad3, npad2, npad1, npad0 – Transmit frame leading pads
The number of character times preceding any frame transmission. A character time is 10 bit times. All zeros in this field disables the leading pads.

npad3	npad2	npad1	npad0	Number of leading pads
0	0	0	0	0
0	0	0	1	1
0	0	1	0	2
1	1	1	1	15

COR3 – SLIP Mode

Register Name: COR3 Register Description: Channel Option Register 3 Default Value: x'00 Access: Byte Read/Write						Intel Hex Address: x'15 Motorola Hex Address: x'16	
Bit 7	Bit 6	Bit 5	Bit 4	Bit 3	Bit 2	Bit 1	Bit 0
Stop2	0	0	0	npad3	npad2	npad1	npad0

Note: SLIP, MNP4, and Automatic In-Band Flow Control modes are only available on Revision B and later devices.

- Bit 7 Stop2
0 = 1 Stop bit
1 = 2 Stop bit
- Bits 6:4 Reserved – *must be zero*.
- Bits 3:0 npad3, npad2, npad1, npad0 – Transmit frame leading pads
The number of character times preceding any frame transmission. A character time is 10 bit times. All zeros in this field disables the leading pads.

npad3	npad2	npad1	npad0	Number of leading pads
0	0	0	0	0
0	0	0	1	1
0	0	1	0	2
1	1	1	1	15

COR3 – MNP4 Mode

Register Name: COR3				Intel Hex Address: x'15			
Register Description: Channel Option Register 3				Motorola Hex Address: x'16			
Default Value: x'00							
Access: Byte Read/Write							
Bit 7	Bit 6	Bit 5	Bit 4	Bit 3	Bit 2	Bit 1	Bit 0
Stop2	0	RxChk	TxGen	npad3	npad2	npad1	npad0

Note: SLIP, MNP4, and Automatic In-Band Flow Control modes are only available on Revision B and later devices.

Bit 7 Stop2
0 = 1 Stop bit
1 = 2 Stop bit

Bit 6 Reserved – *must be zero*.

Bit 5 RxChk – Receive FCS check enabled
When clear, the channel does not test the 2-byte FCS field. All frame data characters are given to the host.
When set, the channel tests the 2-byte FCS field.

Bit 4 TxGen – Transmit FCS enabled
When clear, the channel does not add the 2-byte FCS field.
When set, the channel adds the 2-byte FCS field at the end of the frame.

Bits 3:0 npad3, npad2, npad1, npad0 – Transmit frame leading pads
The number of character times preceding any frame transmission. A character time is 10 bit times. All zeros in this field disables the leading pads.

npad3	npad2	npad1	npad0	Number of leading pads
0	0	0	0	0
0	0	0	1	1
0	0	1	0	2
1	1	1	1	15

COR3 – Programmable Sync Mode

Register Name: COR3 Register Description: Channel Option Register 3 Default Value: x'00 Access: Byte Read/Write						Intel Hex Address: x'15 Motorola Hex Address: x'16	
Bit 7	Bit 6	Bit 5	Bit 4	Bit 3	Bit 2	Bit 1	Bit 0
0	0	0	0	0	0	Append1	Append0

Bit 7:2 Reserved – *must be zero*.

Bits 3:0 Append1, Append0 – Append characters
These bits define the number of characters to be appended to the buffer after receipt of EOF character. The receiver re-enters SYN-hunt mode after the EOF and the programmed number of appended characters, if any, are received.

Append1	Append0	Number of appended characters
0	0	EOF character not appended to frame data
0	1	EOF character is appended to frame data
0	1	Append EOF character and the first byte after EOF
1	1	Append EOF character and the first two bytes after EOF

9.2.5 Channel Option Register 4 (COR4)

Register Name: COR4 Register Description: Channel Option Register 4 Default Value: x'00 Access: Byte Read/Write						Intel Hex Address: x'16 Motorola Hex Address: x'15	
Bit 7	Bit 6	Bit 5	Bit 4	Bit 3	Bit 2	Bit 1	Bit 0
DSRzd	CDzd	CTSzd	0	FIFO Threshold			

(Modem Change Options and FIFO Transfer Threshold)

Bit 7 DSRzd = 1
Detect one-to-zero transition on the DSR* input (zero-to-one transition of DSR (MSVR) bit)

Bit 6 CDzd = 1
Detect one-to-zero transition on the CD* input (zero-to-one transition of CD (MSVR) bit)

Bit 5 CTSzd = 1
Detect one-to-zero transition on the CTS* input (zero-to-one transition of CTS (MSVR) bit)

- Bit 4 Reserved – *must be zero*.
- Bits 3:0 FIFO Threshold in characters
 Note that the maximum value allowed for this field is 12 (0C hex). This 4-bit binary encoded field, sets the FIFO transfer threshold for both transmit and receive FIFOs for both Interrupt and DMA Transfer modes.

In Asynchronous mode, a Good Data transfer is initiated for the number of characters in the FIFO greater than the specified threshold. Receive time-out and the occurrence of a receive data exception are also cause to initiate a receive transfer. In Synchronous modes, data transfer is initiated when the number of characters in the FIFO is greater than the specified threshold. An end of frame also initiates a receive transfer.

For transmit operation, the CD2481 attempts to refill the transmit FIFO when the empty space in the FIFO is greater than the set threshold. In synchronous frame transmissions, the CD2481 stops refilling the transmit FIFO once the last character in the frame has been transferred to the FIFO.

9.2.6 Channel Option Register 5 (COR5)

Register Name: COR5 Register Description: Channel Option Register 5 Default Value: x'00 Access: Byte Read/Write				Intel Hex Address: x'17 Motorola Hex Address: x'14			
Bit 7	Bit 6	Bit 5	Bit 4	Bit 3	Bit 2	Bit 1	Bit 0
DSRod	CDod	CTSod	In/Out	Rx Flow Control Threshold			

This register is used to define the current-state change options to be monitored.

- Bit 7 DSRod = 1
 Detect zero-to-one transition on DSR input (one-to-zero transition of DSR (MSVR) bit)
- Bit 6 CDod = 1
 Detect zero-to-one transition on CD input (one-to-zero transition of CD (MSVR) bit)
- Bit 5 CTSod = 1
 Detect zero-to-one transition on CTS input (one-to-zero transition of CTS (MSVR) bit)
- Bit 4 In/Out – Automatic receive flow control select
 This bit is ignored when bits 3:0 are all zeros.
 0 = Use out-of-band flow control (DTR pin).
 1 = Use in-band flow control (automatic transmission of XOFF/XON characters)

Bit 4	Number of characters in FIFO	CD2481 Action
0	Less than or equal to threshold	DTR asserted
0	Greater than threshold	DTR deasserted
1	Less than or equal to threshold	XON transmitted
1	Greater than threshold	XOFF transmitted

Note: Do not use the STCR (Special Transmit Command register) to send XON and XOFF characters while using automatic in-band flow control.

Bits 3:0 Receive flow control FIFO threshold
 These four bits define the threshold for automatic flow control activation based on the contents of the receive FIFO. A threshold value of zero disables this function and the setting of bit 4 is ignored. Bit 4 determines whether the out-of-band (DTR pin) or the in-band (XOFF/XON characters) is used to stop the flow of incoming data from the remote transmitter.
 When the number of characters in the FIFO exceeds this threshold, the DTR pin deasserts or an XOFF character is transmitted. When the number of characters in the FIFO is less than or equal to the threshold, the DTR asserts or and XON is transmitted.

9.2.7 Channel Option Register 6 (COR6)

COR6 — Async Mode

Register Name: COR6				Intel Hex Address: x'1B			
Register Description: Channel Option Register 6				Motorola Hex Address: x'18			
Default Value: x'00							
Access: Byte Read/Write							
Bit 7	Bit 6	Bit 5	Bit 4	Bit 3	Bit 2	Bit 1	Bit 0
IgnCR	ICRNL	INLCF	IgnBrk	NBrkInt	ParMrk	INPCK	ParInt

CR is defined as 0D hex, NL as 0A hex, and NULL as 00 hex.

Bits 7:5 These three bits are used to enable translation of received CR/NL characters as follows:

IgnCr	ICrRNL	INLCR	
0	0	0	No special action on CR and NL
0	0	1	NL translated to CR
0	1	0	CR translated to NL
0	1	1	CR translated to NL and NL translated to CR
1	0	0	CR discarded

IgnCr	ICrNL	INLCR	
1	0	1	CR discarded and NL translated to CR
1	1	0	CR discarded
1	1	1	CR discarded and NL translated to CR

Bits 4:3 Break Action – These bits determine the action taken after a break condition is received.

IgnBrk	NBrkInt	
0	0	Generate an exception interrupt
0	1	Translate to a NULL character
1	0	Reserved
1	1	Discard character

Bits 2:0 Parity/framing error actions – These bits determine the action taken when a parity or framing error is received.

Following the generation of a break-exception interrupt, a receive exception interrupt is generated with RET bit (RISR1) set, when the end of break is detected. The RET interrupt must be enabled in IER to enable this feature.

ParMrk	INPCK	ParInt	
0	0	0	Generated an exception interrupt
0	0	1	Translated to a NULL character
0	1	0	Ignore error; character passed on as good data
0	1	1	Discard error character
1	0	0	Reserved
1	0	1	Translate to a sequence of FF NULL and the error character and pass on as Good Data
1	1	0	Reserved
1	1	1	Reserved

When ParMrk = 1 and ParInt = 1, each occurrence of FF hex in the data stream is preceded by FF hex to distinguish it from a parity error sequence.

COR6 — Bisync Mode

Register Name: COR6						Intel Hex Address: x'1B	
Register Description: Channel Option 6						Motorola Hex Address: x'18	
Default Value: x'00							
Access: Byte Read/Write							
Bit 7	Bit 6	Bit 5	Bit 4	Bit 3	Bit 2	Bit 1	Bit 0
Special Frame Termination Character							

In Bisynchronous mode, this register provides a frame-termination method for a receive character other than the one already defined in the bisynchronous specification. When an initialize channel command in the CCR is processed, COR6 is set to the value of DLE (hex 10); this deactivates the function because DLE processing is always performed before a match with COR6 is performed. Following the completion of the initialize channel command, the user can program COR6 to any character value where frame termination is required.

One use of this might be to terminate non-transparent frames where the termination character has been corrupted. If the idle line character (hex FF in 8-bit mode, hex 7F in 7-bit mode) is programmed in COR6 when a normal termination character is corrupted (that is, ETX hex 03 is changed to hex 07), the BCC is received as data and the idle line condition causes the frame to terminate. The idle line character is the last character in the frame. No attempt is made to perform a CRC on the receive data under these conditions.

COR6 — X.21 Mode

Register Name: COR6						Intel Hex Address: x'1B	
Register Description: Channel Option 6						Motorola Hex Address: x'18	
Default Value: x'00							
Access: Byte Read/Write							
Bit 7	Bit 6	Bit 5	Bit 4	Bit 3	Bit 2	Bit 1	Bit 0
SYN Character							

In X.21 mode, this register contains the character to be used for find character synchronization with the receive data stream. When the initialize channel command in the CCR is processed, COR6 is set to the value ASCII SYN (hex 16). If the user requires a different synchronization character, COR6 can be loaded with that character after the initialize channel command completes, as in the following sequence:

1. Issue initialize channel command.
2. Wait for command to complete (CCR returns to hex 00).
3. Reprogram COR6 to the desired character.
4. Issue receive enable command by CCR.

COR6 — Programmable Sync Mode

Register Name: COR6 Register Description: Channel Option 6 Default Value: x'00 Access: Byte Read/Write						Intel Hex Address: x'1B Motorola Hex Address: x'18	
Bit 7	Bit 6	Bit 5	Bit 4	Bit 3	Bit 2	Bit 1	Bit 0
SYN1 Character							

In Programmable Sync (CMR mode 0x08) mode, this register defines the SYN1 character, to be used to find character synchronization within the receive data stream. Unused bits must be zero.

9.2.8 Channel Option Register 7 (COR7)

Async Mode

Register Name: COR7 Register Description: Channel Option Register 7 Default Value: x'00 Access: Byte Read/Write						Intel Hex Address: x'04 Motorola Hex Address: x'07	
Bit 7	Bit 6	Bit 5	Bit 4	Bit 3	Bit 2	Bit 1	Bit 0
IStrip	LNE	FCErr	0	0	0	ONLCR	OCRNL

CR is defined as 0D hex, NL as 0A hex and NULL as 00 hex.

Bit 7 IStrip – when this bit is set, the most-significant bit of receive characters is stripped, leaving 7-bit characters. IStrip is applied after all other character processing, but before special character processing.

Bit 6 LNext – this bit enables the LNext option
 0 = All receive characters are processed for special character detection.
 1 = The character following the LNext character is not processed for special character matching or flow control.

This provides a mechanism to transfer flow control and special characters as normal data, without invoking flow control action in the CD2481, and without generating special interrupts. The LNext character is defined in the LNXT register, and when processed, is always passed to the host CPU as normal data.

Bit 5 Flow control on error characters
 0 = Characters received with an error are not processed for special character/flow control matching.
 1 = All receive characters, even those with errors, are processed for special character/flow control processing.

Bits 4:2 Reserved – *must be zero*.

Bits 1:0 Transmit processing for CR and NL; these bits define Translation mode when CR and/or NL are present in the transmit data.

ONLCR	OCRNL	
0	0	No special action
0	1	CR translated to NL
1	0	NL translated to the sequence CR NL
1	1	CR translated to NL and NL translated to the sequence CR NL

COR7 —Programmable Sync Mode

Register Name: COR7						Intel Hex Address: x'04	
Register Description: Channel Option 7						Motorola Hex Address: x'07	
Default Value: x'00							
Access: Byte Read/Write							
Bit 7	Bit 6	Bit 5	Bit 4	Bit 3	Bit 2	Bit 1	Bit 0
SYN2 Character							

In Programmable Sync (CMR mode 0x08) mode, this register defines the SYN2 character, to be used to find character synchronization within the receive data stream. Unused bits must be zero.

9.2.9 Special Character Registers – Async and Programmable Sync Modes

Special Character registers can be used for detecting specific receive characters in the incoming data stream, and can be used in Async Mode to transmit character(s) (by STCR) preempting any data in the transmit FIFO.

9.2.9.1 Special Character Register 1 (SCHR1)

Register Name: SCHR1						Intel Hex Address: x'1C	
Register Description: Special Character Register 2						Motorola Hex Address: x'1F	
Default Value: x'00							
Access: R/W – Async							
Bit 7	Bit 6	Bit 5	Bit 4	Bit 3	Bit 2	Bit 1	Bit 0
User defined special character, protocol defined special characters (see below).							

9.2.9.2 Special Character Register 2 (SCHR2)

Register Name: SCHR2						Intel Hex Address: x'1D	
Register Description: Special Character Register 2						Motorola Hex Address: x'1E	
Default Value: x'00							
Access: R/W – Async							
<i>Bit 7</i>	<i>Bit 6</i>	<i>Bit 5</i>	<i>Bit 4</i>	<i>Bit 3</i>	<i>Bit 2</i>	<i>Bit 1</i>	<i>Bit 0</i>
User defined special character, protocol defined special characters (see below).							

Asynchronous Mode

Special characters 1 and 2 are used in conjunction with the SCDE bit of COR3 to detect incoming characters; when both SCDE and TxIBE (COR2) are set, they define the in-band flow control characters XON and XOFF.

SCHR1 = XON
SCHR2 = XOFF

In addition to the SCDE and TxIBE bits, if the FCT bit (COR3) is set when flow control characters are received, they are stripped from the data stream.

MNP4 Mode

SCHR1 holds the start character.
SCHR2 holds the escape character.

These values vary depending on whether the mode is ARAP 1.0 or ARAP 2.0:

MNP4/ARAP 1.0	ARAP 2.0	
SCHR1	SYN 16 hex	SOH 01 hex
SCHR2	DLE 10 hex	ESC 1B hex

Programmable Sync Mode

SCHR 1-4 define up to four EOF patterns for delimiting frames. If less than the maximum number of EOF patterns is needed (only two, for example), then the unused SCHR registers should duplicate the defined values. In this case, SCHR1 and SCHR2 define two EOF characters, SCHR3 and SCHR4 duplicate these values.

9.2.9.3 Special Character Register 3 (SCHR3)

Register Name: SCHR3						Intel Hex Address: x'1E	
Register Description: Special Character Register 3						Motorola Hex Address: x'1D	
Default Value: x'00							
Access: Byte Read/Write							
<i>Bit 7</i>	<i>Bit 6</i>	<i>Bit 5</i>	<i>Bit 4</i>	<i>Bit 3</i>	<i>Bit 2</i>	<i>Bit 1</i>	<i>Bit 0</i>
User defined special character, protocol defined special character (see below).							

9.2.9.4 Special Character Register 4 (SCHR4)

Register Name: SCHR4						Intel Hex Address: x'1F	
Register Description: Special Character Register 4						Motorola Hex Address: x'1C	
Default Value: x'00							
Access: Byte Read/Write							
<i>Bit 7</i>	<i>Bit 6</i>	<i>Bit 5</i>	<i>Bit 4</i>	<i>Bit 3</i>	<i>Bit 2</i>	<i>Bit 1</i>	<i>Bit 0</i>
User defined special character, protocol defined special character (see below).							

Special characters 3 and 4 are used in conjunction with the ESCDE bit of COR3 to detect characters in the receive data stream and to generate receive special character interrupts.

NOTES:

1. Special characters 3 and 4 are not stripped from the data stream if Flow Control Transparency (FCT) mode is enabled.
2. See “[Programmable Sync Mode](#)” on page 137 for information on SCHR usage in Programmable Synch mode.

9.2.10 Special Character Range – Async Mode Only

9.2.10.1 Special Character Range low (SCRI)

Register Name: SCRL						Intel Hex Address: x'20	
Register Description: Special Character Range, low						Motorola Hex Address: x'23	
Default Value: x'00							
Access: Byte Read/Write							
<i>Bit 7</i>	<i>Bit 6</i>	<i>Bit 5</i>	<i>Bit 4</i>	<i>Bit 3</i>	<i>Bit 2</i>	<i>Bit 1</i>	<i>Bit 0</i>
User Defined Special Character Detect Range, low							

9.2.10.2 Special Character Range high (SCRh)

Register Name: SCRH						Intel Hex Address: x'21	
Register Description: Special Character Range, high						Motorola Hex Address: x'22	
Default Value: x'00							
Access: Byte Read/Write							
<i>Bit 7</i>	<i>Bit 6</i>	<i>Bit 5</i>	<i>Bit 4</i>	<i>Bit 3</i>	<i>Bit 2</i>	<i>Bit 1</i>	<i>Bit 0</i>
User Defined Special Character Detect Range, high							

These registers define an inclusive range for special character recognition in the Asynchronous mode. It can be useful for identifying that a received character is within a user defined range and is, for example, a control character.

9.2.11 LNext Character (LNXT) – Async Mode Only

Register Name: LNXT						Intel Hex Address: x'2D	
Register Description: Literal Next Character						Motorola Hex Address: x'2E	
Default Value: x'00							
Access: Byte Read/Write							
<i>Bit 7</i>	<i>Bit 6</i>	<i>Bit 5</i>	<i>Bit 4</i>	<i>Bit 3</i>	<i>Bit 2</i>	<i>Bit 1</i>	<i>Bit 0</i>
User Defined Literal Next Character							

This register defines the LNext character. If the LNext function is enabled (bit 6 of COR7), the CD2481 examines received characters and compare them against this value. If a match occurs, this character and the following are placed in the FIFO without any special processing. In effect, the LNext function causes the CD2481 to ignore characters with special meaning, such as flow control characters. There are two exceptions: a 'break' or an 'errored' character. If the character following the LNext character is either a 'break' or an 'errored' character, LNext is placed in the FIFO, and the following character is treated as it normally would be for these error conditions.

9.2.12 Receive Frame Address Registers – HDLC Sync Mode Only

9.2.12.1 Receive Frame Address Register 1 (RFAR1)

Register Name: RFAR1						Intel Hex Address: x'1C	
Register Description: Receive Frame Address Register 1						Motorola Hex Address: x'1F	
Default Value: x'00							
Access: Byte Read/Write							
<i>Bit 7</i>	<i>Bit 6</i>	<i>Bit 5</i>	<i>Bit 4</i>	<i>Bit 3</i>	<i>Bit 2</i>	<i>Bit 1</i>	<i>Bit 0</i>
Frame Qualification Address 1							

9.2.12.2 Receive Frame Address Register 2 (RFAR2)

Register Name: RFAR2						Intel Hex Address: x'1D	
Register Description: Receive Frame Address Register 2						Motorola Hex Address: x'1E	
Default Value: x'00							
Access: Byte Read/Write							
<i>Bit 7</i>	<i>Bit 6</i>	<i>Bit 5</i>	<i>Bit 4</i>	<i>Bit 3</i>	<i>Bit 2</i>	<i>Bit 1</i>	<i>Bit 0</i>
Frame Qualification Address 1							

9.2.12.3 Receive Frame Address Register 3 (RFAR3)

Register Name: RFAR3						Intel Hex Address: x'1E	
Register Description: Receive Frame Address Register 3						Motorola Hex Address: x'1D	
Default Value: x'00							
Access: Byte Read/Write							
<i>Bit 7</i>	<i>Bit 6</i>	<i>Bit 5</i>	<i>Bit 4</i>	<i>Bit 3</i>	<i>Bit 2</i>	<i>Bit 1</i>	<i>Bit 0</i>
Frame Qualification Address 3							

9.2.12.4 Receive Frame Address Register 4 (RFAR4)

Register Name: RFAR4						Intel Hex Address: x'1F	
Register Description: Receive Frame Address Register 4						Motorola Hex Address: x'1C	
Default Value: x'00							
Access: Byte Read/Write							
<i>Bit 7</i>	<i>Bit 6</i>	<i>Bit 5</i>	<i>Bit 4</i>	<i>Bit 3</i>	<i>Bit 2</i>	<i>Bit 1</i>	<i>Bit 0</i>
Frame Qualification Address 4							

Reception of an HDLC frame can be qualified with a matched 1- or 2-byte address field either as four 1-byte alternatives or two 2-byte alternatives. The use of RFAR registers for address recognition is described in the Channel Option registers (COR1) on [“Channel Option Register 1 \(COR1\)” on page 114](#).

9.2.13 CRC Polynomial Select Register (CPSR)

Register Name: CPSR						Intel Hex Address: x'D4	
Register Description: CRC Polynomial Select Register						Motorola Hex Address: x'D6	
Default Value: x'00							
Access: Byte Read/Write							
Bit 7	Bit 6	Bit 5	Bit 4	Bit 3	Bit 2	Bit 1	Bit 0
0	0	0	0	0	0	0	Poly

Bits 7:1 Reserved – *must be zero*.

Bit 0 Polynomial select
 0 = CRC V.41 polynomial (normally used for HDLC protocol and preset to 1's)
 $[x^{**16} + x^{**12} + x^{**5} + 1]$
 1 = CRC-16 polynomial (generally used for Bisync but will work in HDLC mode, preset to 0's)
 $[x^{**16} + x^{**15} + x^{**2} + 1]$

9.2.14 Transmit Special Mapped Characters – PPP Mode only

9.2.14.1 Transmit Special Mapped Character 1 (TSPMAP1)

Register Name: TSPMAP1						Intel Hex Address: x'1B	
Register Description: Special Mapped Transmit Character 1						Motorola Hex Address: x'18	
Default Value: x'00							
Access: Byte Read/Write							
Bit 7	Bit 6	Bit 5	Bit 4	Bit 3	Bit 2	Bit 1	Bit 0
User Defined Mapped Transmit Character							

9.2.14.2 Transmit Special Mapped Character 2 (TSPMAP2)

Register Name: TSPMAP2						Intel Hex Address: x'04	
Register Description: Special Mapped Transmit Character 2						Motorola Hex Address: x'07	
Default Value: x'00							
Access: Byte Read/Write							
Bit 7	Bit 6	Bit 5	Bit 4	Bit 3	Bit 2	Bit 1	Bit 0
User Defined Mapped Transmit Character							

9.2.14.3 Transmit Special Mapped Character 3 (TSPMAP3)

Register Name: TSPMAP3 Register Description: Special Mapped Transmit Character 3 Default Value: x'00 Access: Byte Read/Write						Intel Hex Address: x'2D Motorola Hex Address: x'2E	
<i>Bit 7</i>	<i>Bit 6</i>	<i>Bit 5</i>	<i>Bit 4</i>	<i>Bit 3</i>	<i>Bit 2</i>	<i>Bit 1</i>	<i>Bit 0</i>
User Defined Mapped Transmit Character							

The three TSPMAP registers are used to provide control character escape processing on characters outside the 00–1F (hex) range. Each of these three registers are scanned to match the character currently being transmitted; if a match occurs, that character is 'escaped' before transmission. If a zero value is found in any of them, the scan is terminated. (Zero is already covered in the standard TXACCM.)

9.2.15 Transmit Async Control Character Maps – Async-HDLC/PPP Mode Only

9.2.15.1 Transmit Async Control Character Map 0 (TXACCM0)

Register Name: TXACCM0 Register Description: Transmit Async Control Character Map 0 Default Value: x'00 Access: Byte Read/Write						Intel Hex Address: x'1C Motorola Hex Address: x'1F	
<i>Bit 7</i>	<i>Bit 6</i>	<i>Bit 5</i>	<i>Bit 4</i>	<i>Bit 3</i>	<i>Bit 2</i>	<i>Bit 1</i>	<i>Bit 0</i>
Char. 07	Char. 06	Char. 05	Char. 04	Char. 03	Char. 02	Char. 01	Char. 00

9.2.15.2 Transmit Async Control Character Map 1 (TXACCM1)

Register Name: TXACCM1 Register Description: Transmit Async Control Character Map 1 Default Value: x'00 Access: Byte Read/Write						Intel Hex Address: x'1D Motorola Hex Address: x'1E	
<i>Bit 7</i>	<i>Bit 6</i>	<i>Bit 5</i>	<i>Bit 4</i>	<i>Bit 3</i>	<i>Bit 2</i>	<i>Bit 1</i>	<i>Bit 0</i>
Char. 0F	Char. 0E	Char. 0D	Char. 0C	Char. 0B	Char. 0A	Char. 09	Char. 08

9.2.15.3 Transmit Async Control Character Map 2 (TXACCM2)

Register Name: TXACCM2						Intel Hex Address: x'1E	
Register Description: Transmit Async Control Character Map 2						Motorola Hex Address: x'1D	
Default Value: x'00							
Access: Byte Read/Write							
<i>Bit 7</i>	<i>Bit 6</i>	<i>Bit 5</i>	<i>Bit 4</i>	<i>Bit 3</i>	<i>Bit 2</i>	<i>Bit 1</i>	<i>Bit 0</i>
Char. 17	Char. 16	Char. 15	Char. 14	Char. 13	Char. 12	Char. 11	Char. 10

9.2.15.4 Transmit Async Control Character Map 3 (TXACCM3)

Register Name: TXACCM3						Intel Hex Address: x'1F	
Register Description: Transmit Async Control Character Map 3						Motorola Hex Address: x'1C	
Default Value: x'00							
Access: Byte Read/Write							
<i>Bit 7</i>	<i>Bit 6</i>	<i>Bit 5</i>	<i>Bit 4</i>	<i>Bit 3</i>	<i>Bit 2</i>	<i>Bit 1</i>	<i>Bit 0</i>
Char. 1F	Char. 1E	Char. 1D	Char. 1C	Char. 1B	Char. 1A	Char. 19	Char. 18

The TXACCM registers define transmitted characters in the range 00–1F as mapped (Control bit set) or not mapped (Control bit clear) as follows:

- TXACCM0 bits 0–7 control characters 00–07, respectively.
- TXACCM1 bits 0–7 control characters 08–0F, respectively.
- TXACCM2 bits 0–7 control characters 10–17, respectively.
- TXACCM3 bits 0–7 control characters 18–1F, respectively.

9.2.16 Receive Async Control Character Maps – Async-HDLC/PPP Mode Only

9.2.16.1 Receive Async Control Character Map 0 (RXACCM0)

Register Name: RXACCM0						Intel Hex Address: x'20	
Register Description: Receive Async Control Character Map 0						Motorola Hex Address: x'23	
Default Value: x'00							
Access: Byte Read/Write							
<i>Bit 7</i>	<i>Bit 6</i>	<i>Bit 5</i>	<i>Bit 4</i>	<i>Bit 3</i>	<i>Bit 2</i>	<i>Bit 1</i>	<i>Bit 0</i>
Char. 07	Char. 06	Char. 05	Char. 04	Char. 03	Char. 02	Char. 01	Char. 00

9.2.16.2 Receive Async Control Character Map 1 (RXACCM1)

Register Name: RXACCM1						Intel Hex Address: x'21	
Register Description: Receive Async Control Character Map 1						Motorola Hex Address: x'22	
Default Value: x'00							
Access: Byte Read/Write							
Bit 7	Bit 6	Bit 5	Bit 4	Bit 3	Bit 2	Bit 1	Bit 0
Char. 0F	Char. 0E	Char. 0D	Char. 0C	Char. 0B	Char. 0A	Char. 09	Char. 08

9.2.16.3 Receive Async Control Character Map 2 (RXACCM2)

Register Name: RXACCM2						Intel Hex Address: x'22	
Register Description: Receive Async Control Character Map 2						Motorola Hex Address: x'21	
Default Value: x'00							
Access: Byte Read/Write							
Bit 7	Bit 6	Bit 5	Bit 4	Bit 3	Bit 2	Bit 1	Bit 0
Char. 17	Char. 16	Char. 15	Char. 14	Char. 13	Char. 12	Char. 11	Char. 10

9.2.16.4 Receive Async Control Character Map 3 (RXACCM3)

Register Name: RXACCM3						Intel Hex Address: x'23	
Register Description: Receive Async Control Character Map 3						Motorola Hex Address: x'20	
Default Value: x'00							
Access: Byte Read/Write							
Bit 7	Bit 6	Bit 5	Bit 4	Bit 3	Bit 2	Bit 1	Bit 0
Char. 1F	Char. 1E	Char. 1D	Char. 1C	Char. 1B	Char. 1A	Char. 19	Char. 18

The RXACCM registers define received characters in the range 00–1F as mapped (Control bit set) or not mapped (Control bit clear) as follows:

- RXACCM0 bits 0–7 control characters 00–07, respectively.
- RXACCM1 bits 0–7 control characters 08–0F, respectively.
- RXACCM2 bits 0–7 control characters 10–17, respectively.
- RXACCM3 bits 0–7 control characters 18–1F, respectively.

9.3 Bit Rate and Clock Option Registers

9.3.1 Receive Baud Rate Generator Registers

9.3.1.1 Receive Baud Rate Period Register (RBPR)

Register Name: RBPR				Intel Hex Address: x'C9			
Register Description: Receive Bit-Rate Period Register				Motorola Hex Address: x'CB			
Default Value: x'81							
Access: Byte Read/Write							
Bit 7	Bit 6	Bit 5	Bit 4	Bit 3	Bit 2	Bit 1	Bit 0
Receive Bit Rate Period (Divisor)							

This register contains the preload value for the receive baud rate counter. When using an internal clock option or an n-times external clock, the preload value in conjunction with the receiver clock source chosen, determines the receive baud rate. If a 1× external clock is used, a value of 01h must be loaded in the RBPR.

9.3.1.2 Receive Clock Option Register (RCOR)

Register Name: RCOR				Intel Hex Address: x'CA			
Register Description: Receive Clock Option Register				Motorola Hex Address: x'C8			
Default Value: x'00							
Access: Byte Read/Write							
Bit 7	Bit 6	Bit 5	Bit 4	Bit 3	Bit 2	Bit 1	Bit 0
TLVal	0	DpllEn	Dpllmd1	Dpllmd0	ClkSel2	ClkSel1	ClkSel0

This register is used to select the DPLL mode, and the desired clock source for the receive baud rate generator.

- Bit 7 TLVal – Transmit line value
This bit reflects the logical value of the transmit data pin. It is a read-only bit; writing to this bit has no effect.
- Bit 6 Reserved – *must be zero*.
- Bit 5 DPLL enable
1 = DPLL is enabled
0 = DPLL is disabled
- Bits 4:3 DPLL mode selects the type of data encoding used.

Dpllmd1	Dpllmd0	Encoding
0	0	NRZ
0	1	NRZI
1	0	Manchester
1	1	Reserved

Bits 2:0 These three bits select the clock source for the receive baud rate generator or DPLL.

clkSel2	clkSel1	clkSel0	Clock Source
0	0	0	Clk 0
0	0	1	Clk 1
0	1	0	Clk 2
0	1	1	Clk 3
1	0	0	Clk 4
1	0	1	Reserved
1	1	0	External clock
1	1	1	Reserved

Note: See the description of clock options in [Section 5.5](#).

9.3.2 Transmit Baud Rate Generator Registers

9.3.2.1 Transmit Baud Rate Period Register (TBPR)

Register Name: TBPR				Intel Hex Address: x'C1			
Register Description: Transmit Bit-Rate Period Register				Motorola Hex Address: x'C3			
Default Value: x'81							
Access: Byte Read/Write							
Bit 7	Bit 6	Bit 5	Bit 4	Bit 3	Bit 2	Bit 1	Bit 0
Transmit Bit Rate Period (Divisor)							

This register contains the preload value for the transmit baud rate count. When using one of the internal clocks or an n-times external clock, the preload value in conjunction with the transmitter clock source chosen, determines the transmit baud rate. If a 1× external clock or the receive clock is used, a value of 01h must be loaded in the TBPR.

9.3.2.2 Transmit Clock Option Register (TCOR)

Register Name: TCOR				Intel Hex Address: x'C2			
Register Description: Transmit Clock Option Register				Motorola Hex Address: x'C0			
Default Value: x'00							
Access: Byte Read/Write							
Bit 7	Bit 6	Bit 5	Bit 4	Bit 3	Bit 2	Bit 1	Bit 0
ClkSel2	ClkSel1	ClkSel0	0	Ext-1X	0	LLM	0

This register controls the transmit baud rate generator and Local Loopback mode.

Bits 7:5 These bits select the clock source for the transmit baud rate generator.

ClkSel2	ClkSel1	ClkSel0	Select
0	0	0	Clk 0
0	0	1	Clk 1
0	1	0	Clk 2
0	1	1	Clk 3
1	0	0	Clk 4
1	0	1	Reserved
1	1	0	External clock
1	1	1	Receive clock

Note: See the description of clock options in [Section 5.5](#).

Bit 4 Reserved – *must be zero*.

Bit 3 Times 1 external clock. This bit is set to '1' when user supplies the data clock on TxCIN[i] pin whose frequency is equal to the transmit data rate. When using the external 1× clock or the clock from the receiver's DPLL, the TBPR must be programmed to 01h.

Bit 2 Reserved – *must be zero*.

Bit 1 Local Loopback mode
 1 = enables the Local Loopback mode
 0 = disables the Local Loopback mode

Bit 0 Reserved – *must be zero*.

9.4 Channel Command and Status Registers

9.4.1 Channel Command Register (CCR)

There are two CCR command sets. Mode 1 (if bit 7 is '0') commands affect basic channel control. In Mode 2 (if bit 7 is '1'), additional commands that control timer functions are available.

CCR - Mode 1

Register Name: CCR				Intel Hex Address: x'10			
Register Description: Channel Command Register, Mode 1				Motorola Hex Address: x'13			
Default Value: x'00							
Access: Byte Read/Write							
Bit 7	Bit 6	Bit 5	Bit 4	Bit 3	Bit 2	Bit 1	Bit 0
0	ClrCh	InitCh	RstAll	EnTx	DisTx	EnRx	DisRx

The various command and control bits in this register perform largely independent functions. The host can assert multiple command bits to achieve the desired effect. The CD2481 clears the register to zero after it accepts and acts on a host command. The host must verify that the contents of this register are zero prior to issuing a new command. If the RESET ALL command is issued, all other commands are ignored. All other combinations are legal, and the order of processing is as follows:

1. Clear channel
2. Initialize channel
3. Enable receive
4. Disable receive
5. Enable transmit
6. Disable transmit

Note: Processing CCR commands is a low-priority task for the internal firmware, since they seldom occur. The user must take care when waiting for command completions at critical times, that is, during interrupt service routines.

Channel Control Commands (Bit 7 = 0)

Bit 7 Must be zero.

Bit 6 Clear channel command
 When this command is issued, the CD2481 clears the data FIFOs and current transmit and receive status of the channel in the CSR. If the channel is currently transmitting a frame in synchronous protocol, the host should issue the transmit abort, special transmit command, before issuing a clear command. The channel parameters are not affected by a channel clear command. The clear channel command causes both receive and transmit FIFOs to be cleared, the transmitter and receiver to be disabled and all DMA Status registers (DMABSTS, A/BRBSTS and A/BTBSTS) to be cleared.

Bit 5 Initialize channel
 If any change is made to the Protocol Mode Select bits in the CMR (Channel Mode register) or to the COR1 (Channel Option Register 1), the channel must be reinitialized by this command. The command causes the internal protocol-specific registers to be initialized.

Note: If the Initialize Channel command is issued after a channel is already in operation, then a Clear Channel command must be issued prior to, or coincident with, the Initialize Channel command. Failure to observe this requirement will result in unpredictable device behavior.

Bit 4 Reset all
 An on-chip firmware initialization of all channels is performed. All channel and global parameters are reset to their power-on reset condition. This command is the strongest the host can issue. None of the other command bits are interpreted if the RESET ALL command is given. The host must re-initialize the CD2481 following the execution of this command just as after a hardware power-on reset. When this command is completed, the GFRCCR is updated with the firmware revision code.

Bit 3 Enable transmitter
 Enables the transmitter by setting TxEn bit in the CSR (Channel Status register). In Asynchronous mode, this command also clears the transmit flow control options.

Bit 2 Disable transmitter
 Disables the transmitter by clearing TxEn bit in the CSR. In Asynchronous mode, the Transmit Flow Control bits are cleared.

Bit 1 Enable receiver
 Enables the receiver by setting the RxEn bit in the CSR. In Asynchronous mode, the Receive Flow Control bits are cleared.

Bit 0 Disable receiver
 Disables the receiver by clearing the RxEn bit in the CSR. In Asynchronous mode, the Receive Flow Control bits are cleared.

CCR Mode 2

Register Name: CCR						Intel Hex Address: x'10	
Register Description: Channel Command Register, Mode 2						Motorola Hex Address: x'13	
Default Value: x'00							
Access: Byte Read/Write							
Bit 7	Bit 6	Bit 5	Bit 4	Bit 3	Bit 2	Bit 1	Bit 0
1	ClrT1	ClrT2	ClrRx	ClrTx	0	0	0

Either one or both of the timers can be cleared with a single command. Note that if the running timer value is 01h at the time this command is issued, there is a small chance that the timer expires and causes a timer interrupt before the command is processed.

Bit 7 Must be one.

Bit 6 Clear timer 1
 General timer 1 is cleared.

- Bit 5 Clear timer 2
General timer 2 is cleared.
- Bit 4 Clear receiver command
This command only affects the receiver. It resets all receiver functions like a combination of clear channel and initialize channel commands. ClrRx clears the receive FIFO and clears receive status in the CSR, except for the RxEn bit. ClrRx clears receive DMA buffer status in ARBSTS, BRBSTS, and Receive Status bits in DMABSTS. Clearing the 2481OWN bits in both the Receive Buffer Status registers means that DMA buffers have to be returned to the CD2481 before receive transfers begin again.
- For Synchronous modes, this command puts the receiver back into Syn/Flag Hunt mode.
- Bit 3 Clear Transmitter Command
This command only affects the transmitter; it is *only* available on Revision C and later devices and only effective in asynchronous protocols. It resets all transmitter functions like a combination of clear channel and initialize channel commands. ClrTx clears the transmit FIFO and clears transmit status in the CSR, except for the TxEn bit.
- ClrTx clears transmit DMA buffer status in ATBSTS, BTBSTS, and Transmit Status bits in DMABSTS. Clearing the CD2481 own bits in both the Transmit Buffer Status registers means that DMA buffers have to be returned to the CD2481 before transmit transfers begin again.
- Bits 2:0 Reserved – *must be zero*.

9.4.2 Special Transmit Command Register (STCR)

STCR – Async and HDLC Modes

Register Name: STCR						Intel Hex Address: x'11	
Register Description: Special Transmit Command Register						Motorola Hex Address: x'12	
Default Value: x'00							
Access: Byte Read/Write							
Bit 7	Bit 6	Bit 5	Bit 4	Bit 3	Bit 2	Bit 1	Bit 0
0	AbortTx	AppdCmp	0	SndSpC	SSPC2	SSPC1	SSPC0

The CD2481 clears the register to zero when it accepts a host CPU command.

- Bit 7 Reserved – *must be zero*.
- Bit 6 Abort transmission (HDLC)
Terminates the frame currently in transmission with an abort sequence. In DMA mode, all data up to the next EOF is discarded.



- Bit 5 Append complete (Asynchronous DMA mode only)
This bit should be set by the host when the last addition has been made to the append buffer.
- Bit 4 Reserved – *must be zero*.
- Bit 3 Send special character(s) command
In Asynchronous mode, sends a user-defined special character or special-character sequence. The special character is transmitted ahead of any data remaining in the FIFO.
- Bits 2:0 Special character select

SSPC2	SSCP1	SSPC0	Function
0	0	0	Reserved
0	0	1	Send Special Character 1
0	1	0	Send Special Character 2
0	1	1	Send Special Character 3
1	0	0	Send Special Character 4
1	0	1	Reserved
1	1	0	Reserved
1	1	1	Reserved

Note: The user should not use the send XON/XOFF commands if automatic in-band flow control is enabled (Asynchronous modes only) in COR5.

STCR –Async-HDLC/PPP Mode

Register Name: STCR						Intel Hex Address: x'11	
Register Description: Special Transmit Command Register						Motorola Hex Address: x'12	
Default Value: x'00							
Access: Byte Read/Write							
Bit 7	Bit 6	Bit 5	Bit 4	Bit 3	Bit 2	Bit 1	Bit 0
0	AbortTx	0	0	SndSpc	Frame	XON	XOFF

Special characters can be transmitted preemptively (ahead of any characters in the transmit FIFO) upon commands described below. When the special character is transmitted, the STCR is cleared by the device.

- Bit 7 Reserved – *must be zero*.
- Bit 6 Abort
Transmission of the two-character sequence (7D–7E) aborts the current transmit frame. All data in the FIFO following the abort is discarded. If DMA is used, the remaining data up to the EOF is discarded.
- Bits 5:4 Reserved – *must be zero*.



- Bit 3 sndsp – Send special character command
When clear, the frame, XON, and XOFF bits described below have no meaning.
When set, the host should also set one of the following bits: frame, XON, or XOFF.
- Bit 2 frame – Send framing error
Causes the next character in the transmit stream to be sent with an incorrect Stop bit (Stop bit is '0').
This bit is intended as a test function. Unlike the Abort bit, this bit does not terminate the transmission.
- Bit 1 XON – Send XON
Causes the transmission of an XON (cntl-Q or hex 11).

Note: The user should not use the send XON/XOFF commands if automatic in-band flow control is enabled (Asynchronous modes only) in COR5.

- Bit 0 XOFF – Send XOFF
Causes the transmission of an XOFF (cntl-S or hex 13).

The command structure associated with the sndsp Control bit is:

sndsp	frame	XON	XOFF	Action
0	X	X	X	Send Special Disabled
1	1	X	X	Send one character with FE
1	0	1	X	Send XON
1	0	0	1	Send XOFF

Note: The user should not use the send XON/XOFF commands if automatic in-band flow control is enabled (Asynchronous modes only) in COR5.

STCR –SLIP/MNP4 Mode

Register Name: STCR						Intel Hex Address: x'11	
Register Description: Special Transmit Command Register						Motorola Hex Address: x'12	
Default Value: x'00							
Access: Byte Read/Write							
Bit 7	Bit 6	Bit 5	Bit 4	Bit 3	Bit 2	Bit 1	Bit 0
0	AbortTx	0	0	SndSpc	Frame	0	0

Special characters can be transmitted preemptively (ahead of any characters in the transmit FIFO) upon commands described below. When the special character is transmitted, the STCR is cleared by the device.

- Bit 7 Reserved – *must be zero.*
- Bit 6 Abort
Transmission of the two-character sequence (7D–7E) aborts the current transmit

frame. All data in the FIFO following the abort is discarded. If DMA is used, the remaining data up to the EOF is discarded.

- Bits 5:4 Reserved – *must be zero*.
- Bit 3 sndsp – Send special character command
When clear, the frame, XON, and XOFF bits described below have no meaning.
When set, the host should also set one of the following bits: frame, XON, or XOFF.
- Bit 2 frame – Send framing error
Causes the next character in the transmit stream to be sent with an incorrect stop bit (stop bit is '0').
This bit is intended as a test function. Unlike the Abort bit, this bit does not terminate the transmission.
- Bits 1:0 Reserved – *must be zero*.

9.4.3 Channel Status Register (CSR)

This status register stores the current state of the channel. It can be read by the host at any time. The states of the RxEn and the TxEn bits are controlled by host CPU commands to the CCR.

CSR – HDLC Mode

Register Name: CSR				Intel Hex Address: x'19			
Register Description: Channel Status Register				Motorola Hex Address: x'1A			
Default Value: x'00							
Access: Byte Read/Write							
Bit 7	Bit 6	Bit 5	Bit 4	Bit 3	Bit 2	Bit 1	Bit 0
RxEn	RxFlag	RxFrame	RxMark	TxEn	TxFlag	TxFrame	TxMark

- Bit 7 Receiver enable
0 = Receiver is disabled
1 = Receiver is enabled
- Bit 6 Rx flag
0 = Currently not receiving flag/sync
1 = Currently receiving flag/sync
- Bit 5 Rx frame
0 = Currently not receiving frame
1 = Currently receiving frame
- Bit 4 Rx mark
0 = Currently not receiving continuous mark
1 = Currently receiving continuous mark
- Bit 3 Transmitter enable
0 = Transmitter is disabled
1 = Transmitter is enabled

- Bit 2 Tx flag
0 = Currently not transmitting flag
1 = Currently transmitting flag
- Bit 1 Tx frame
0 = Currently not transmitting frame
1 = Currently transmitting frame
- Bit 0 Tx mark
0 = Currently not transmitting continuous ones
1 = Currently transmitting continuous ones

CSR –Bisynchronous Mode

Register Name: CSR				Intel Hex Address: x'19			
Register Description: Channel Status Register				Motorola Hex Address: x'1A			
Default Value: x'00							
Access: Byte Read/Write							
Bit 7	Bit 6	Bit 5	Bit 4	Bit 3	Bit 2	Bit 1	Bit 0
RxEn	RxITB	RxFrame	0	TxEn	TxITB	TxFrame	0

- Bit 7 Receiver enabled status
0 = Receiver disabled.
1 = Receiver enabled.
- Bit 6 Receive ITB
This bit indicates that the last frame received was terminated with an ITB. This means that the leading character of the next receive frame is included in the BCC calculation.
- Bit 5 Receive frame
This bit, when set, indicates that the CD2481 is currently receiving a frame.
- Bit 4 Reserved – returns '0' when read.
- Bit 3 Transmitter enabled status
0 = Transmitter disabled.
1 = Transmitter enabled.
- Bit 2 Transmit ITB
This bit is set if the last frame transmitted ended with and ITB character, that is, the leading character of the next frame is included in the BCC calculation.
- Bit 1 Transmit frame status
This bit, when set, indicates that the CD2481 is currently transmitting a frame.
- Bit 0 Reserved – returns '0' when read.

9.4.3.1 CSR —Asynchronous Mode

Register Name: CSR				Intel Hex Address: x'19			
Register Description: Channel Status Register				Motorola Hex Address: x'1A			
Default Value: x'00							
Access: Byte Read/Write							
Bit 7	Bit 6	Bit 5	Bit 4	Bit 3	Bit 2	Bit 1	Bit 0
RxEn	RxFloff	RxFlon	0	TxEEn	TxFloff	TxFlon	0

If the host determines that a flow control state is inappropriate, it can be cleared by enabling or disabling the transmitter or receiver by CCR command.

- Bit 7 Receiver enable
0 = Receiver is disabled
1 = Receiver is enabled

- Bit 6 Receive flow off
0 = Normal
1 = The CD2481 has requested the remote to stop transmission (Send XOFF command has been given to the channel). This bit is reset when the CD2481 has requested the remote to restart transmission, or when the receiver is enabled or disabled, or the channel is reset.

- Bit 5 Receive flow on
0 = Normal
1 = The CD2481 has requested the remote to restart character transmission (Send XON command has been given to the channel). This bit is reset when the next (non-flow control) character is received, or when the receiver is enabled or disabled, or the channel is reset.

- Bit 4 Reserved – returns '0' when read.

- Bit 3 Transmitter enable
0 = Transmitter is disabled
1 = Transmitter is enabled

- Bit 2 Transmit flow off
0 = Normal
1 = The CD2481 has been requested by the remote to stop transmission. This bit is reset when the CD2481 receives a request to resume transmission, or when the transmitter is enabled or disabled, or the channel is reset.

- Bit 1 Transmit flow on
0 = Normal
1 = The CD2481 has been requested by the remote to resume transmission. This bit is reset once character transmission is resumed, or when the transmitter is enabled or disabled, or the channel is reset.

- Bit 0 Reserved – returns '0' when read.



CSR —X.21 Mode

Register Name: CSR				Intel Hex Address: x'19			
Register Description: Channel Status Register				Motorola Hex Address: x'1A			
Default Value: x'00							
Access: Byte Read/Write							
Bit 7	Bit 6	Bit 5	Bit 4	Bit 3	Bit 2	Bit 1	Bit 0
RxEn	0	RxSpc	0	TxEn	0	TxSpc	0

- Bit 7 Receiver enabled status
0 = Receiver disabled.
1 = Receiver enabled.
- Bit 6 Reserved – returns '0' when read.
- Bit 5 Receive special
This bit, when set, indicates that the CD2481 is currently in a steady state condition. Such conditions generate a receive special character interrupt.
- Bit 4 Reserved – returns '0' when read.
- Bit 3 Transmitter enabled status
0 = Transmitter disabled.
1 = Transmitter enabled.
- Bit 2 Reserved – returns '0' when read.
- Bit 1 Transmit special
This bit, when set, indicates that the CD2481 is currently transmitting an ETC command, as defined in COR2.
- Bit 0 Reserved – returns '0' when read.

CSR –Async-HDLC/PPP Mode

Register Name: CSR				Intel Hex Address: x'19			
Register Description: Channel Status Register				Motorola Hex Address: x'1A			
Default Value: x'00							
Access: Byte Read/Write							
Bit 7	Bit 6	Bit 5	Bit 4	Bit 3	Bit 2	Bit 1	Bit 0
RxEn	RxFloff	RxFrame	Ridle	TxEn	TxFloff	TxFrame	Tidle

- Bit 7 RxEn – Receiver enabled status
When set, the receiver is enabled.
When clear, the receiver is disabled.



- Bit 6 RxFloff – Receive flow off status
 When set, XOFF has been transmitted as commanded in the STCR. RxFloff indicates that the remote station has been requested to stop transmission. RxFloff remains set until the host issues an STCR command to send an XON, or when the receiver is enabled or disabled, or the channel is reset.

When clear, the remote station is not requested to stop transmission. RxFloff remains set until the host issues an STCR command to send an XON.
- Bit 5 RFram – Receive frame status
 When set, a frame is being received.
 When clear, no frame is being received.
- Bit 4 RIdle – Receiver idle status
 When set, the receiver input is idle.
 When clear, the receiver input is not idle.
 Notice that RFram and RIdle are mutually exclusive.
- Bit 3 TxEn – Transmitter enabled status
 When set, the transmitter is enabled.
 When clear, the transmitter is disabled.
- Bit 2 TxFloff– Transmit flow off status
 This bit has no meaning unless TxIBE in COR2 is set.
 When set, an XOFF has been received, and the transmitter has stopped sending data.
 When clear, the transmitter is able to transmit if there are characters to send.
- Bit 1 TFram – Transmit frame status
 When set, a frame is being transmitted.
 When clear, no frame is being transmitted.
- Bit 0 TIdle – Transmitter idle status
 When set, the transmitter output is idle.
 When clear, the transmitter output is not idle.
 Note that TFram and TIdle are mutually exclusive.

CSR –SLIP/MNP4 Mode

Register Name: CSR Register Description: Channel Status Register Default Value: x'00 Access: Byte Read/Write						Intel Hex Address: x'19 Motorola Hex Address: x'1A	
Bit 7	Bit 6	Bit 5	Bit 4	Bit 3	Bit 2	Bit 1	Bit 0
RxEn	0	RxFrame	Ridle	TxEn	0	TxFrame	Tidle

- Bit 7 RxEn – Receiver enabled status
 When set, the receiver is enabled.
 When clear, the receiver is disabled.
- Bit 6 Reserved – returns '0' when read.

- Bit 5 RFrame – Receive frame status
When set, a frame is being received.
When clear, no frame is being received.

- Bit 4 RIdle – Receiver idle status
When set, the receiver input is idle.
When clear, the receiver input is not idle.
Note that RFrame and RIdle are mutually exclusive.

- Bit 3 TxEn – Transmitter enabled status
When set, the transmitter is enabled.
When clear, the transmitter is disabled.

- Bit 2 Reserved – returns ‘0’ when read.

- Bit 1 TFrame – Transmit frame status
When set, a frame is being transmitted.
When clear, no frame is being transmitted.

- Bit 0 TIdle – Transmitter idle status
When set, the transmitter output is idle.
When clear, the transmitter output is not idle.
Note that TFrame and TIdle are mutually exclusive.

9.4.4 Modem Signal Value Registers (MSVR)

Modem Signal Value Register (MSVR-RTS)

Register Name: MSVR-RTS Register Description: Modem Signal Value Register - RTS Default Value: x'00 Access: Byte Read/Write						Intel Hex Address: x'DC Motorola Hex Address: x'DE	
Bit 7	Bit 6	Bit 5	Bit 4	Bit 3	Bit 2	Bit 1	Bit 0
DSR	CD	CTS	DTRop	0	0	DTR	RTS

Modem Signal Value Register (MSVR-DTR)

Register Name: MSVR-DTR Register Description: Modem Signal Value Register - DTR Default Value: x'00 Access: Byte Read/Write						Intel Hex Address: x'DD Motorola Hex Address: x'DF	
Bit 7	Bit 6	Bit 5	Bit 4	Bit 3	Bit 2	Bit 1	Bit 0
DSR	CD	CTS	DTRop	0	0	DTR	RTS

Either of these registers is read to determine the current input levels on the input modem pins. Note that the pin definitions for these signals is negative true while the register values are positive true. Two registers are provided for control of the outputs — DTR and RTS. Writing to the MSVR-DTR register affects only the DTR pin. Writing to the MSVR-RTS register affects only the RTS pin.

- Bit 7 DSR – Current state of data set ready input
- Bit 6 CD – Current state of carrier detect input
- Bit 5 CTS – Current state of clear to send input
- Bit 4 DTR option – written by MSVR-DTR register
0 = value of DTR bit is output on TXCOUT/DTR* pin
1 = Transmit clock is output on TXCOUT/DTR* pin

Note: If the transmit clock source is a 1× clock on the TXCIN pin, this signal cannot be driven on TXCOUT/DTR*.

- Bit 3:2 Reserved – returns ‘0’ when read; writing has no effect
- Bit 1 DTR – Current state of data terminal ready output
- Bit 0 RTS – Current state of request to send output

9.5 Interrupt Registers

9.5.1 General Interrupt Registers

9.5.1.1 Local Interrupt Vector Register (LIVR)

Register Name: LIVR						Intel Hex Address: x'0A	
Register Description: Local Interrupt Vector Register						Motorola Hex Address: x'09	
Default Value: x'00							
Access: Byte Read/Write							
Bit 7	Bit 6	Bit 5	Bit 4	Bit 3	Bit 2	Bit 1	Bit 0
X	X	X	X	X	X	IT1	IT0

The host effectively controls bits 7:2; the device provides bits 1 and 0 within an interrupt acknowledge context.

The CD2481 has one Local Interrupt Vector register per channel, each with six host-defined bits. The host can choose to embed the channel number and the protocol in use on the channel in the channel vector. The CD2481 supplies two modified bits signifying the type of interrupt service required.

- Bits 7:2 User-defined. These six bits can be used as the CD2481 device ID number.
- Bits 1:0 Interrupt type. These three bits indicate the group/type of interrupt occurring.

IT[1:0]	Group	Type
01	Group 1	Modem signal change interrupt/ general timer interrupt
10	Group 2	Transmit data interrupt
11	Group 3	Receive data interrupt
00	Group 4	Receive exception interrupt

Note that because the CD2481 provides a unique Local Interrupt Vector register for each channel, the host has the option to include the channel number within the interrupt vector.

9.5.1.2 Interrupt Enable Register (IER)

Non-Async-HDLC/PPP Modes

Register Name: IER				Intel Hex Address: x'12			
Register Description: Interrupt Enable Register				Motorola Hex Address: x'11			
Default Value: x'00							
Access: Byte Read/Write							
Bit 7	Bit 6	Bit 5	Bit 4	Bit 3	Bit 2	Bit 1	Bit 0
Mdm	0	RET	0	RxD	TIMER	TxMpty	TxD

- Bit 7 Modem pin change detect
Master interrupt enable for modem change detect functions. The host can select which modem pins are watched for input change and select either or both directions of change by programming the change detect option bits in COR4 and COR5. A group1 type interrupt (see LIVR description) is generated from this enable.
- Bit 6 Reserved – *must be zero*.
- Bit 5 RET (Async)
In Asynchronous mode, this bit enables a group 3 receive exception time-out interrupt when a receive data time-out occurs with an empty receive FIFO. This provides a mechanism for the host to manage a partially full receive buffer when receive data stops.
- Bit 4 Reserved – *must be zero*.
- Bit 3 Rx data
The receive FIFO threshold has been reached in Interrupt Transfer mode, causing a group 3 receive data interrupt. Any receive exception causes a group 3 receive exception interrupt.
- Bit 2 Timer
General timer(s) time-out
In Synchronous mode, this bit enables a group 1 interrupt when either timer reaches zero.

- Bit 1 Tx Mpty
Transmitter empty. If enabled, a group 2 interrupt is generated when the channel is completely empty of transmit data.
- Bit 0 Tx Data
Any transmit exception or transmit FIFO threshold reached in Interrupt Transfer mode. Group 2 interrupts are generated at the end of transmit DMA buffers or when the FIFO threshold is reached in Interrupt Transfer mode.

IER –Async-HDLC/PPP Mode

Register Name: IER					Intel Hex Address: x'12		
Register Description: Interrupt Enable Register					Motorola Hex Address: x'11		
Default Value: x'00							
Access: Byte Read/Write							
Bit 7	Bit 6	Bit 5	Bit 4	Bit 3	Bit 2	Bit 1	Bit 0
Mdm	0	0	0	RxD	TIMER	TxMpty	TxD

- Bit 7 Modem pin change detect
Master interrupt enable for modem change detect functions. The host can select which modem pins are watched for input change and select either or both directions of change by programming the change detect option bits in COR4 and COR5. A group1 type interrupt (see LIVR description) is generated from this enable.
- Bit 6:4 Reserved – *must be zero.*
- Bit 3 Rx data
The receive FIFO threshold has been reached in Interrupt Transfer mode, causing a group 3 receive data interrupt. Any receive exception causes a group 3 receive exception interrupt.
- Bit 2 Timer
General timer(s) time-out
In Synchronous mode, this bit enables a group 1 interrupt when either timer reaches zero.
- Bit 1 Tx Mpty
Transmitter empty. If enabled, a group 2 interrupt is generated when the channel is completely empty of transmit data.
- Bit 0 Tx Data
Any transmit exception or transmit FIFO threshold reached in Interrupt Transfer mode. Group 2 interrupts are generated at the end of transmit DMA buffers or when the FIFO threshold is reached in Interrupt Transfer mode.

9.5.1.3 Local Interrupting Channel Register (LICR)

Register Name: LICR						Intel Hex Address: x'25	
Register Description: Local Interrupting Channel Register						Motorola Hex Address: x'26	
Default Value: C1:C0 contain channel number							
Access: Byte Read/Write							
<i>Bit 7</i>	<i>Bit 6</i>	<i>Bit 5</i>	<i>Bit 4</i>	<i>Bit 3</i>	<i>Bit 2</i>	<i>Bit 1</i>	<i>Bit 0</i>
X	X	X	X	C1	C0	X	X

These per-channel registers are initialized with each channel number. The locations are RAM registers and can be used for any purpose.

Bits 7:4 User-defined

Bits 3:2 Defines the interrupting channel number

C1	C0	Channel Number
0	0	Channel 0
0	1	Channel 1
1	0	Channel 2
1	1	Channel 3

Bits 1:0 User-defined

9.5.1.4 Interrupt Stack Register (STK)

Register Name: STK						Intel Hex Address: x'E0	
Register Description: Interrupt Stack Register						Motorola Hex Address: x'E2	
Default Value: x'00							
Access: Byte Read Only							
<i>Bit 7</i>	<i>Bit 6</i>	<i>Bit 5</i>	<i>Bit 4</i>	<i>Bit 3</i>	<i>Bit 2</i>	<i>Bit 1</i>	<i>Bit 0</i>
CLvl [1]	MLvl [1]	TLvl [1]	0	0	TLvl [0]	MLvl [0]	CLvl [0]

This register is a 4-bit-deep by 2-bit-wide stack that holds the internal interrupt nesting history. The stack is pushed from bits 7 and 0 towards the center during an interrupt acknowledge cycle and popped from the center during a write to an end of interrupt register.

Bits 7, 0 CLvl [0:1] These bits provide the currently active interrupt level.

CLvl [1]	CLvl [0]	
0	0	No interrupt active; CAR provides the current channel number
0	1	Currently in a modem interrupt service, MIR provides the current channel number.
1	0	Currently in a transmit interrupt service, TIR provides the current channel number.
1	1	Currently in a receive interrupt service, RIR provides the current channel number.

- Bits 6, 1 MLvl [0:1] These bits hold a previously active interrupt now nested.
- Bits 5, 2 TLvl [0:1] These bits hold the oldest interrupt now nested 2 bit deep.
- Bits 4:3 Reserved – returns ‘0’ when read.

9.5.2 Receive Interrupt Registers

9.5.2.1 Receive Priority Interrupt Level Register (RPILR)

Register Name: RPILR		Intel Hex Address: x'E3					
Register Description: Receive Priority Interrupt Match Register		Motorola Hex Address: x'E1					
Default Value: x'00							
Access: Byte Read/Write							
Bit 7	Bit 6	Bit 5	Bit 4	Bit 3	Bit 2	Bit 1	Bit 0
User Assigned Receive Priority Match Value							

This register must be initialized by the host to contain the codes that are presented on the address bus by the host system to indicate which of the three CD2481 interrupt types (modem, transmit, or receive) is being acknowledged when IACKIN* is asserted. The CD2481 compares bits 0–6 in this register with A[0–6] to determine if the acknowledge level is correct. The value programmed in the MSB of the register has no effect on the IACK cycle.

RPILR must contain the code used to acknowledge receive interrupts.

Note: Bit 7 of the register is always read back as ‘0’. When each of the three Priority Interrupt Level registers is programmed with the same value, they are internally prioritized, with receive as the highest priority, followed by transmit and modem.

9.5.2.2 Receive Interrupt Register (RIR)

Register Name: RIR				Intel Hex Address: x'EF			
Register Description: Receive Interrupt Register				Motorola Hex Address: x'ED			
Default Value: x'00							
Access: Byte Read Only							
Bit 7	Bit 6	Bit 5	Bit 4	Bit 3	Bit 2	Bit 1	Bit 0
Ren	Ract	Reoi	0	Rvct [1]	Rvct [0]	Rcn [1]	Rcn [0]

Bit 7 **Ren**
 Receive enable is set by the CD2481 to initiate a receive interrupt request sequence. It is cleared during a valid receive interrupt acknowledge cycle.

Bit 6 **Ract**
 Receive active is set automatically when Ren is set, and the Fair Share logic allows the assertion of a receive interrupt request. It is cleared when the host CPU writes to the Receive End of Interrupt register.

Bit 5 **Reoi**
 Receive end of interrupt is set automatically when the host CPU writes to the Receive End of Interrupt register while in a receive interrupt routine.

Ren	Ract	Reoi	Sequence of Events
0	0	0	Idle
1	0	0	Receive interrupt requested, but not asserted
1	1	0	Receive interrupt asserted
0	1	0	Receive interrupt acknowledged
0	0	1	Receive interrupt service routine completed

Bit 4 Reserved – returns '0' when read.

Bits 3:2 **Rvct [1:0]**
 Receive vector bits are set by the CD2481 to provide the lower two bits of the vector supplied to the host CPU during an interrupt acknowledge cycle. Receive good data vector is decoded as follows: Rvct [1] = 1, and Rvct [0] = 1. Receive exception vector is decoded as follows: Rvct [1] = 0, and Rvct [0] = 0.

Bit 1:0 **Rcn [1:0]**
 Receive channel number is set by the CD2481 to indicate the channel requiring receive interrupt service.

9.5.2.3 Receive Interrupt Status Register (RISR)

Register Name: RISR						Intel Hex Address: x'8A	
Register Description: Receive Interrupt Status Register						Motorola Hex Address: x'88	
Default Value: x'00							
Access: Word Read/Write							
Bit 15	Bit 14	Bit 13	Bit 12	Bit 11	Bit 10	Bit 9	Bit 8
RISR High							
Bit 7	Bit 6	Bit 5	Bit 4	Bit 3	Bit 2	Bit 1	Bit 0
RISR Low							

This register reports the status of the channel during the receive interrupt service. It is a 16-bit register, with the lower byte displaying current receive character oriented status while the upper byte displays current DMA interrupt status. The upper byte is not used if DMA mode is not active.

Note: During an interrupt service routine, the host can use this register to provide a timer value as detailed in the Receive End of Interrupt register. The host can only load one of the two timers in the interrupt service routine.

RISRI – HDLC Mode

Register Name: RISRI						Intel Hex Address: x'8A	
Register Description: Receive Interrupt Status Register - Low						Motorola Hex Address: x'89	
Default Value: x'00							
Access: Byte Read Only							
Bit 7	Bit 6	Bit 5	Bit 4	Bit 3	Bit 2	Bit 1	Bit 0
0	EOF	RxAbt	CRC	OE	ResInd	0	ClrDct
Bit 7	Bit 6	Bit 5	Bit 4	Bit 3	Bit 2	Bit 1	Bit 0
Binary Value for Timer							

If RxData in IER is set, these interrupts are enabled.

- Bit 7 Reserved – returns '0' when read.
- Bit 6 Receiving a data frame is essentially complete.
- Bit 5 Received abort sequence terminating the frame.
- Bit 4 CRC error on current frame.



- Bit 3 Overrun error – indicates that new data has arrived, but the CD2481 FIFO or holding registers are full. The new data is lost, and the overrun indication is flagged on the last character received before the overrun occurred. In HDLC and Bisync modes, the remainder of a frame, following an overrun, is discarded.
- Bit 2 Residual indication – indicates that the last character of the frame was a partial character.
- Bit 1 Reserved – returns ‘0’ when read.
- Bit 0 Clear detect – indicates an X.21 data transfer phase clear signal has been detected. This is defined as two consecutive all-zero receive characters with the CTS* pin high. Clear Detect mode is enabled by COR1.

Note: During an interrupt service routine, the host can use this register to provide a timer value as detailed in the Receive End of Interrupt register. The host can only load one of the two timers in the interrupt service routine.

RISRI –Bisynchronous Mode

Register Name: RISRI				Intel Hex Address: x'8A			
Register Description: Receive Interrupt Status Register - Low				Motorola Hex Address: x'89			
Default Value: x'00							
Access: Byte Read/Write							
Bit 7	Bit 6	Bit 5	Bit 4	Bit 3	Bit 2	Bit 1	Bit 0
0	EOF	RxAbt	CRC	OE	0	0	0
Bit 7	Bit 6	Bit 5	Bit 4	Bit 3	Bit 2	Bit 1	Bit 0
Binary Value for Timer							

- Bit 7 Reserved – returns ‘0’ when read.
- Bit 6 EOF – End of frame
The EOF bit indicates that a valid End Of Frame has been received, and the frame is essentially complete.
- Bit 5 rxabt – Receive abort
The rxabt bit indicates that an abort sequence terminating the frame has been received.
- Bit 4 CRC – Receive CRC error
(The terms CRC and FCS are used interchangeably in this document.)
The CRC bit indicates that a frame with a valid end of frame has been received, but the FCS was not correct.
- Bit 3 OE – Overrun Error
The OE bit indicates that the receiver buffer and FIFO have been overrun. At least one new character has been received, but lost since there was no room available in

the receiver buffer and/or FIFO. The OE status is set on the last character received before the overrun occurred.

Bit 2:0 Reserved – returns ‘0’ when read.

Note: During an interrupt service routine, the host can use this register to provide a timer value as detailed in the Receive End of Interrupt register. The host can only load one of the two timers in the interrupt service routine.

RISRI – Asynchronous Mode

Register Name: RISRI				Intel Hex Address: x'8A			
Register Description: Receive Interrupt Status Register - Low				Motorola Hex Address: x'89			
Default Value: x'00							
Access: Byte Read Only							
Bit 7	Bit 6	Bit 5	Bit 4	Bit 3	Bit 2	Bit 1	Bit 0
Timeout	SCdet2	SCdet1	SCdet0	OE	PE	FE	Break

Bit 7	Bit 6	Bit 5	Bit 4	Bit 3	Bit 2	Bit 1	Bit 0
Binary Value for Timer							

If RxData in IER is set, these interrupts are enabled.

Bit 7 Timeout – indicates that the receive FIFO is empty, and no data has been received within the receive time-out period. There is no data character associated with this status, and no other status bits are valid if the Time-Out bit is set.

Bits 6:4 Special character detect

SCdet[2:0]	Status
000	None detected
001	Special Character 1 matched
010	Special Character 2 matched
011	Special Character 3 matched (only if ESCDE is enabled in COR3)
100	Special Character 4 matched (only if ESCDE is enabled in COR3)
111	Character is within the inclusive range of the characters in the Special Character Range low and high registers (only if RngDE is enabled in COR3). Special character match can be enabled for error characters by COR7.

Bit 3 Overrun error – indicates that new data has arrived, but the CD2481 FIFO or holding registers are full. The new data is lost and the overrun indication is flagged on the last character received before the overrun occurred.

Bit 2 Parity error – indicates that a parity error has occurred.

Bit 1 Framing error – indicates that a bad Stop bit has been detected.

Bit 0 Break – indicates that a break has been detected.

Note: During an interrupt service routine, the host can use this register to provide a timer value as detailed in the Receive End of Interrupt register. The host can only load one of the two timers in the interrupt service routine.

RISRI –X.21 Mode

Register Name: RISRI						Intel Hex Address: x'8A	
Register Description: Receive Interrupt Status Register - Low						Motorola Hex Address: x'89	
Default Value: x'00							
Access: Byte Read/Write							
Bit 7	Bit 6	Bit 5	Bit 4	Bit 3	Bit 2	Bit 1	Bit 0
LVal	SCDET2	SCDET1	SCDET0	OE	PE	0	LChg
Bit 7	Bit 6	Bit 5	Bit 4	Bit 3	Bit 2	Bit 1	Bit 0
Binary Value for Timer							

For X.21 operation, the CTS* pin is used as the 'T' lead for DTE or 'C' lead for DCE; a low level on CTS* is interpreted as an ON condition and a high level as an OFF condition.

Bit 7 Lead value
0 = Off
1 = On

Bits 6:4 Special character detect
This indication occurs if two consecutive characters matching the value indicated in the table below are received:

SCdet[2:0]	Status
000	None detected
001	Matched the value in SCHR1
010	Matched the value in SCHR2
011	Matched the value in SCHR3
100	All '0' condition
101	All '1' condition
110	Alternating '0' and '1' condition
111	SYN detect

Bit 3 Overrun error
The OE bit indicates that the receiver buffer and FIFO have been overrun. At least one new character has been received, but lost since there was no room available in

the receiver buffer and/or FIFO. The OE status is set on the last character received before the overrun occurred.

- Bit 2 Parity error
This bit indicates that a parity error occurred on this character.
- Bit 1 Reserved; returns '0' when read.
- Bit 0 Lead change
This bit indicates a change of state on the CTS* pin from the previous character time. Because there is no character sync during some phases of the X.21 call setup, an Lchg indication can precede a special character interrupt.

Note: During an interrupt service routine, the host can use this register to provide a timer value as detailed in the Receive End of Interrupt register. The host can only load one of the two timers in the interrupt service routine.

RISRI – Async-HDLC / PPP / MNP4 Mode

Register Name: RISRI						Intel Hex Address: x'8A	
Register Description: Receive Interrupt Status Register - Low						Motorola Hex Address: x'89	
Default Value: x'00							
Access: Byte Read Only							
Bit 7	Bit 6	Bit 5	Bit 4	Bit 3	Bit 2	Bit 1	Bit 0
0	EOF	RxAbt	CRC	OE	FE	0	Break
Bit 7	Bit 6	Bit 5	Bit 4	Bit 3	Bit 2	Bit 1	Bit 0
Binary Value for Timer							

If RxData in IER is set, these interrupts are enabled.

- Bit 7 Reserved; returns '0' when read.
- Bit 6 EOF – End of frame
The EOF bit indicates that a valid end of frame (7E) character has been received, and the 7E was not preceded by a 7D.
- Bit 5 rxabt – Receive abort
The rxabt bit indicates that an abort sequence (7D–7E) has been received.
- Bit 4 CRC – Receive CRC error
(The terms CRC and FCS are used interchangeably in this document.)
The CRC bit indicates that a frame with a valid end of frame has been received, but the FCS was not correct. CRC is set only if EOF is set.
- Bit 3 OE – Overrun error
The OE bit indicates that the receiver buffer and FIFO have been overrun. At least one new character has been received, but lost since there was no room available in the receiver buffer and/or FIFO.



- Bit 2 FE – Framing error
The FE bit indicates that a character has been received with an incorrect Stop bit. The stop bit was '0'; it should have been '1'.
- Bit 1 Reserved; returns '0' when read.
- Bit 0 Break – Break detection
The Break bit indicates that a break has been received. A break is a continuous sequence of at least ten '0' bits.

NOTES:

1. During an interrupt service routine, the host can use this register to provide a timer value as detailed in the Receive End of Interrupt register. The host can only load one of the two timers in the interrupt service routine.
2. OE, FE, and break are cumulative over the entire packet in PPP mode. This means that the respective error occurred somewhere in the packet, but did not cause an immediate interrupt.
3. The table to the right defines the encoding of RxABT and FE for an aborted receive frame:

RxABT	FE	Error
0	0	None
0	1	Not Used
1	0	Received abort sequence: x'7D, x'7E
1	1	Framing Error caused a frame abort

RISRI – SLIP/MNP4 Mode

Register Name: RISRI				Intel Hex Address: x'8A			
Register Description: Receive Interrupt Status Register - Low				Motorola Hex Address: x'89			
Default Value: x'00							
Access: Byte Read Only							
Bit 7	Bit 6	Bit 5	Bit 4	Bit 3	Bit 2	Bit 1	Bit 0
0	EOF	RxAbt	0	OE	FE	0	Break
Bit 7	Bit 6	Bit 5	Bit 4	Bit 3	Bit 2	Bit 1	Bit 0
Binary Value for Timer							

If RxData in IER is set, these interrupts are enabled.

- Bit 7 Reserved; returns '0' when read.
- Bit 6 EOF – End of frame
The EOF bit indicates that a valid end of frame (7E) character has been received, and the 7E was not preceded by a 7D.

Bit 5	rxabt – Receive abort The rxabt bit indicates that an abort sequence (7D–7E) has been received.
Bit 4	Reserved; returns ‘0’ when read.
Bit 3	OE – Overrun error The OE bit indicates that the receiver buffer and FIFO have been overrun. At least one new character has been received, but lost since there was no room available in the receiver buffer and/or FIFO.
Bit 2	FE – Framing error The FE bit indicates that a character has been received with an incorrect Stop bit. The Stop bit was ‘0’; it should have been ‘1’.
Bit 1	Reserved; returns ‘0’ when read.
Bit 0	Break – Break detection The Break bit indicates that a break has been received. A break is a continuous sequence of at least ten ‘0’ bits.

NOTES:

1. During an interrupt service routine, the host can use this register to provide a timer value as detailed in the Receive End of Interrupt register. The host can only load one of the two timers in the interrupt service routine.
2. OE, FE, and break are cumulative over the entire packet in PPP mode. This means that the respective error occurred somewhere in the packet, but did not cause an immediate interrupt.

9.5.2.4 Receive Interrupt Status Register high (RISRh)

Register Name: RISRh					Intel Hex Address: x’8B		
Register Description: Receive Interrupt Status Register - High					Motorola Hex Address: x’88		
Default Value: x’00							
Access: Byte Read Only							
Bit 7	Bit 6	Bit 5	Bit 4	Bit 3	Bit 2	Bit 1	Bit 0
Berr	EOF	EOB	0	BA/BB	0	0	0

This register is used in DMA mode only.

Bit 7	Bus error (written by CD2481) 0 = No bus error 1 = Bus error was detected on the last transfer The actual address at which the error occurred is available in the Receive Current Buffer Address register. In response to a bus error status, the host has two possible options: 1. Retry from the next position in the buffer. 2. Terminate this buffer by setting TermBuff bit in REOIR, and move onto the next.
Bit 6	Reception of a data frame is complete (Sync DMA mode only).

Bit 5	The end of a receive buffer has been reached. Used only for DMA supported transmission. The end of one of the host-supplied receive buffers has been reached.
Bit 4	Reserved; returns '0' when read.
Bit 3	Status during buffer A or buffer B data transfer 0 = Buffer A 1 = Buffer B
Bits 2:0	Reserved; returns '0' when read.

9.5.2.5 Receive FIFO Output Count (RFOC)

Register Name: RFOC						Intel Hex Address: x'33	
Register Description: Receive FIFO Output Count Register						Motorola Hex Address: x'30	
Default Value: x'00							
Access: Byte Read Only							
Bit 7	Bit 6	Bit 5	Bit 4	Bit 3	Bit 2	Bit 1	Bit 0
0	0	0	RxCt4	RxCt3	RxCt2	RxCt1	RxCt0

Bits 7:5 Reserved; returns '0' when read.

Bits 4:0 Receive data count
If the receive channel is interrupt driven, a non-zero value in this bit field is the number of data characters available for transfer within the current receive interrupt.

9.5.2.6 Receive Data Register (RDR)

Register Name: RDR						Intel Hex Address: x'F8	
Register Description: Receive Data Register						Motorola Hex Address: x'F8	
Default Value: x'00							
Access: Byte Read Only							
Bit 7	Bit 6	Bit 5	Bit 4	Bit 3	Bit 2	Bit 1	Bit 0
D7	D6	D5	D4	D3	D2	D1	D0

This Virtual register accesses the receive data FIFO of a channel interrupting for receive data transfer. This register address is used for all channels to transfer receive FIFO data to the host, if programmed in Interrupt Transfer mode. Data must be read as bytes, and follows the rules listed in [Section 9.3](#) for the positioning of valid data on the bus. If the BYTESWAP pin is high, data is valid on A/D[0–7], if BYTESWAP is low, data is valid on A/D[8–15]. This is true because the RDR is on an even address.

9.5.2.7 Receive End of Interrupt Register (REOIR)

REOIR –HDLC / Bisync / Asynchronous / X.21 Modes

Register Name: REOIR				Intel Hex Address: x'87			
Register Description: Receive End of Interrupt Register				Motorola Hex Address: x'84			
Default Value: x'00							
Access: Byte Write Only							
Bit 7	Bit 6	Bit 5	Bit 4	Bit 3	Bit 2	Bit 1	Bit 0
TermBuff	DiscExc	SetTm2	SetTm1	NoTrans	Gap2	Gap1	Gap0

The CD2481 interprets values written to this register at the completion of all receive interrupts.

- Bit 7** Terminate current DMA buffer
 If this bit is set, the current receive buffer is terminated and data transfer is switched to the other buffer. This bit should only be set in response to an async exception interrupt. If the buffer is terminated in response to an exception character (that is, parity error) interrupt and the discard exception character bit is not set, the exception character is written at the start of the next buffer.
- Before writing the terminate buffer command to REOIR, a new buffer descriptor can be written to the current buffer.
- Bit 6** Discard exception character (DMA mode only)
 When this bit is set in response to an async exception interrupt, the exception character is not transferred to memory.
- Bit 5** Set general timer 2 in Synchronous modes
 0 = do not set general timer
 1 = load the value, to general timer 2, provided in RISRI.
- Bit 4** Set general timer 1 in Synchronous modes
 0 = do not set general timer 1
 1 = load the value, to the high byte of general timer 1, provided in RISRI.
- At the end of an interrupt service routine, the user can set a timer by setting a timer value in the Receive Interrupt Status register. When the timer reaches '0', the CD2481 generates a modem/timer group interrupt to the host.
- Bit 3** No transfer of data
 This bit must be set by the host, if no data is transferred from the receive FIFO during a receive interrupt.
- Bits 2:0** Gap2, Gap1, Gap0
 Size of the optional gaps to be left in DMA buffer, starting at the current location, before resuming data transfer. The CD2481 moves forward its buffer address pointer to the selected number of bytes. It does not write to any location 'in the gap'. If the gap is large enough to complete, or extend beyond the end of the current buffer, it is completed, and the gap continued in the other receive buffer. If the discard exception character is not selected, the character on which the exception occurred is written to the buffer following the gap.

REOIR – Async-HDLC / PPP / SLIP / MNP4 Modes

Register Name: REOIR						Intel Hex Address: x'87	
Register Description: Receive End of Interrupt Register						Motorola Hex Address: x'84	
Default Value: x'00							
Access: Byte Write Only							
Bit 7	Bit 6	Bit 5	Bit 4	Bit 3	Bit 2	Bit 1	Bit 0
TermBuff	DiscExc	SetTm2	SetTm1	NoTrans	0	0	0

The CD2481 interprets values written to this register at the completion of all receive interrupts.

- Bit 7** Terminate current DMA buffer
 If this bit is set, the current receive buffer is terminated and data transfer is switched to the other buffer. This bit should only be set in response to an async exception interrupt. If the buffer is terminated in response to an exception character (that is, parity error) interrupt and the discard exception character bit is not set, the exception character is written at the start of the next buffer.
- Before writing the terminate buffer command to REOIR, a new buffer descriptor can be written to the current buffer.
- Bit 6** Discard exception character (DMA mode only)
 When this bit is set in response to an async exception interrupt, the exception character is not transferred to memory.
- Bit 5** Set general timer 2 in Synchronous modes
 0 = do not set general timer
 1 = load the value, to general timer 2, provided in RISRI.
- Bit 4** Set general timer 1 in Synchronous modes
 0 = do not set general timer 1
 1 = load the value, to the high byte of general timer 1, provided in RISRI.
- At the end of an interrupt service routine, the user can set a timer by setting a timer value in the Receive Interrupt Status register. When the timer reaches '0', the CD2481 generates a modem/timer group interrupt to the host.
- Bit 3** No transfer of data
 This bit must be set by the host, if no data is transferred from the receive FIFO during a receive interrupt.
- Bits 2:0** Reserved - *must be zero*.

9.5.3 Transmit Interrupt Registers

9.5.3.1 Transmit Priority Interrupt Level Register (TPILR)

Register Name: TPILR						Intel Hex Address: x'E2	
Register Description: Transmit Priority Interrupt Match Register						Motorola Hex Address: x'E0	
Default Value: x'00							
Access: Byte Read/Write							
Bit 7	Bit 6	Bit 5	Bit 4	Bit 3	Bit 2	Bit 1	Bit 0
User Assigned Transmit Priority Match Value							

This register must be initialized by the host to contain the codes that are presented on the address bus by the host system to indicate which of the three CD2481 interrupt types (modem, transmit, or receive) is being acknowledged when IACKIN* is asserted. The CD2481 compares bits 0–6 in this register with A[0–6] to determine if the acknowledge level is correct. The value programmed in the MSB of the register has no effect on the IACK cycle.

The TPILR must contain the code used to acknowledge transmit interrupts.

Note: Bit 7 of this register is always read back as '0'. When each of the three Priority Interrupt Level registers are programmed with the same value, they are internally prioritized, with receive as the highest priority, followed by transmit and modem.

9.5.3.2 Transmit Interrupt Register (TIR)

Register Name: TIR						Intel Hex Address: x'EE	
Register Description: Transmit Interrupt Register						Motorola Hex Address: x'EC	
Default Value: None, value varies							
Access: Byte Read Only							
Bit 7	Bit 6	Bit 5	Bit 4	Bit 3	Bit 2	Bit 1	Bit 0
Ten	Tact	Teoi	0	Tvct [1]	Tvct [0]	Tcn [1]	Tcn [0]

Bit 7 **Ten**
 Transmit enable is set by the CD2481 to initiate a transmit interrupt request sequence. It is cleared during a valid transmit interrupt acknowledge cycle.

Bit 6 **Tact**
 Transmit active is set automatically when Ten is set, and the Fair Share logic allows the assertion of a transmit interrupt request. It is cleared when the host CPU writes to the Transmit End of Interrupt register.

Bit 5 **Teoi**
 Transmit end of interrupt is set automatically when the host CPU writes to the Transmit End of Interrupt register while in a transmit interrupt routine.

Ten	Tact	Teoi	Sequence of Events
0	0	0	Idle
1	0	0	Transmit interrupt requested, but not asserted
1	1	0	Transmit interrupt asserted
0	1	0	Transmit interrupt acknowledged
0	0	1	Transmit interrupt service routine completed

Bit 4 Unused; returns '0' when read.

Bits 3:2 Tvct [1:0]
Transmit Vector bits are set by the CD2481 to provide the lower two bits of the vector supplied to the host CPU during an interrupt acknowledge cycle. Transmit vector is decoded as follows: Tvct [1] = 1, and Tvct [0] = 0.

Bit 1:0 Tcn [1:0]
Transmit channel number is set by the CD2481 to indicate the channel requiring transmit interrupt service.

9.5.3.3 Transmit Interrupt Status Register (TISR)

Register Name: TISR						Intel Hex Address: x'89	
Register Description: Transmit Interrupt Status Register						Motorola Hex Address: x'8A	
Default Value: x'00							
Access: Byte Read Only							
Bit 7	Bit 6	Bit 5	Bit 4	Bit 3	Bit 2	Bit 1	Bit 0
Berr	EOF	EOB	UE	BA/BB	0	TxEmpty	TxDat
Bit 7	Bit 6	Bit 5	Bit 4	Bit 3	Bit 2	Bit 1	Bit 0
Binary Value for Timer							

When the host receives a transmit interrupt, the following status is provided in this register:

Bit 7 Berr – Bus error (written by the CD2481)
0 = no bus error
1 = bus error was detected on the last transfer

Bit 6 EOF – Transmit end of frame indication in the DMA mode
This interrupt occurs when the final data character of a transmit frame is transferred to the transmit FIFO.

Bit 5 EOB – Transmit end of buffer indication in the DMA mode

- Bit 4 Transmit underrun error (HDLC only), otherwise zero (Async, PPP, SLIP, and MNP4).
- Bit 3 BA/BB – Applicable buffer for the register interrupt
0 = Transmit Buffer A
1 = Transmit Buffer B
- Bit 2 Reserved; returns ‘0’ when read.
- Bit 1 TxEmpty – Transmitter empty
All characters have been completely transmitted, and the serial output is idle.
- Bit 0 TxDat – The number of characters in the FIFO is below the threshold.

Note: During an interrupt service routine, the host can use this register to provide a timer value as detailed in the Receive End of Interrupt register. The host can only load one of the two timers in the interrupt service routine.

9.5.3.4 Transmit FIFO Transfer Count (TFTC)

Register Name: TFTC						Intel Hex Address: x'83	
Register Description: Transmit FIFO Transfer Count Register						Motorola Hex Address: x'80	
Default Value: x'00							
Access: Byte Read Only							
Bit 7	Bit 6	Bit 5	Bit 4	Bit 3	Bit 2	Bit 1	Bit 0
0	0	0	TxCt4	TxCt3	TxCt2	TxCt1	TxCt0

- Bits 7:5 Reserved - *must be zero*.
- Bits 4:0 Transmit data count
If the Transmit channel is interrupt driven, a non-zero value is a request for data. These bits give the number of spaces available in the transmit FIFO.

9.5.3.5 Transmit Data Register (TDR)

Register Name: TDR						Intel Hex Address: x'F8	
Register Description: Transmit Data Register						Motorola Hex Address: x'F8	
Default Value: x'00							
Access: Byte Write Only							
Bit 7	Bit 6	Bit 5	Bit 4	Bit 3	Bit 2	Bit 1	Bit 0
D7	D6	D5	D4	D3	D2	D1	D0

This register accesses the transmit data FIFO of a channel, interrupting for transmit data transfer. This register address is used for all channels to transfer transmit FIFO data to the host, if programmed in Interrupt Transfer mode. Data must be written as bytes, and follows the rules listed

in [Section 8.4](#) for positioning valid data on the bus. If the BYTESWAP pin is high, data must be valid on A/D[0–7]; if BYTESWAP is low, data must be valid on A/D[8–15], because the TDR is on an even address.

9.5.3.6 Transmit End of Interrupt Register (TEOIR)

Register Name: TEOIR				Intel Hex Address: x'86			
Register Description: Transmit End of Interrupt Register				Motorola Hex Address: x'85			
Default Value: x'00							
Access: Byte Write Only							
Bit 7	Bit 6	Bit 5	Bit 4	Bit 3	Bit 2	Bit 1	Bit 0
TermBuff	EOF	SetTm2	SetTm1	Notrans	0	0	0

The Transmit End of Interrupt register must be written to by the corresponding host interrupt service routine to signal to the CD2481 that the current interrupt service is concluded. This must be the last access to the CD2481 during an interrupt service routine. Writing to this register generates an internal end of interrupt signal which pops the CD2481 interrupt context stack.

Depending on the circumstances of an individual interrupt service, the host can be required to pass a parameter to the CD2481 through these registers.

Bit 7 1 = Terminate buffer in DMA mode forces the current buffer to be discarded.

Note: If current interrupt is a transmit end-of-buffer interrupt, setting this bit at the end of the service routine causes the next buffer to be terminated also.

Bit 6 End of frame in Synchronous modes using interrupt-driven data transfer
0 = this data transfer does not complete the frame/block.
1 = this data transfer does complete the frame/block.

Bit 5 Set general timer 2 (Synchronous modes only)
0 = do not set general timer 2.
1 = load the value, provided in TISR, to general timer 2.

Bit 4 Set general timer 1 (Synchronous modes only)
0 = do not set general timer 1.
1 = load the value, provided in TISR, to the high byte of general timer 1.

At the end of an interrupt service routine, the user can set a timer by setting a timer value in the Transmit Interrupt Status register. When the timer reaches '0', the CD2481 generates a modem/timer group interrupt to the host.

Bit 3 No transfer of data
This bit must be set by the host, if no data is transferred to the transmit FIFO during a data transfer interrupt.

Bits 2:0 Reserved – *must be zero*.

9.5.4 Modem Interrupt Registers

9.5.4.1 Modem Priority Interrupt Level Register (MPILR)

Register Name: MPILR						Intel Hex Address: x'E1	
Register Description: Modem Priority Interrupt Match Register						Motorola Hex Address: x'E3	
Default Value: x'00							
Access: Byte Read/Write							
Bit 7	Bit 6	Bit 5	Bit 4	Bit 3	Bit 2	Bit 1	Bit 0
User Assigned Modem Priority Match Value							

This register must be initialized by the host to contain the codes that are presented on the address bus by the host system to indicate which of the three CD2481 interrupt types (modem, transmit, or receive) is being acknowledged when IACKIN* is asserted. The CD2481 compares bits 0–6 in this register with A[0–6] to determine if the acknowledge level is correct. The value programmed in the MSB of the register has no effect on the IACK cycle.

The MPILR must contain the code used to acknowledge modem/timer interrupts.

Note: Bit 7 of this register is always read back as '0'. When each of the three Priority Interrupt Level registers is programmed with the same value, they are internally prioritized, with receive as the highest priority, followed by transmit and modem.

9.5.4.2 Modem Interrupt Register (MIR)

Register Name: MIR						Intel Hex Address: x'ED	
Register Description: Modem Interrupt Register						Motorola Hex Address: x'EF	
Default Value: x'00							
Access: Byte Read Only							
Bit 7	Bit 6	Bit 5	Bit 4	Bit 3	Bit 2	Bit 1	Bit 0
Men	Mact	Meoi	0	Mvct [1]	Mvct [0]	Mcn [1]	Mcn [0]

Bit 7 **Men**
Modem enable is set by the CD2481 to initiate a modem interrupt request sequence. It is cleared during a valid modem interrupt acknowledge cycle.

Bit 6 **Mact**
Modem active is set automatically when Men is set, and the Fair Share logic allows the assertion of a modem interrupt request. It is cleared when the host CPU writes to the Modem End of Interrupt register.

Bit 5 **Meoi**
Modem end of interrupt is set automatically when the host CPU writes to the Modem End of Interrupt register while in a modem interrupt routine.

Mact	Meoi	Sequence of Events	
0	0	0	Idle
1	0	0	Modem interrupt requested, but not asserted
1	1	0	Modem interrupt asserted
0	1	0	Modem interrupt acknowledged
0	0	1	Modem interrupt service routine completed

- Bit 4 Reserved; returns '0' when read.
- Bits 3:2 Mvct [1:0]
Modem Vector bits are set by the CD2481 to provide the lower two bits of the vector supplied to the host CPU during an interrupt acknowledge cycle. Modem vector is decoded as follows: Mvct [1] = 0, and Mvct [0] = 1.
- Bit 1:0 Mcn [1:0]
Modem channel number is set by the CD2481 to indicate the channel requiring modem interrupt service.

9.5.4.3 Modem (/Timer) Interrupt Status Register (MISR)

Register Name: MISR						Intel Hex Address: x'88	
Register Description: Modem Interrupt Status Register						Motorola Hex Address: x'8B	
Default Value: x'00							
Access: Byte Read/Write							
Bit 7	Bit 6	Bit 5	Bit 4	Bit 3	Bit 2	Bit 1	Bit 0
DSRChg	CDChg	CTSChg	Reserved			Timer2	Timer1
Bit 7	Bit 6	Bit 5	Bit 4	Bit 3	Bit 2	Bit 1	Bit 0
Binary Value for Timer							

When the host receives a modem interrupt, the following status is provided in this register:

- Bit 7 DSR changed
A logic '1' indicates that a change has been detected on the DSR* input. The change detect is programmed in COR4 and COR5.
- Bit 6 CD changed
A logic '1' indicates that a change has been detected on the CD* input. The change detect is programmed in COR4 and COR5.



- Bit 5 CTS changed
A logic '1' indicates that a change has been detected on the CTS* input. The change detect is programmed in COR4 and COR5.
- Bits 4:2 Reserved; returns '0' when read
- Bit 1 General timer 2 timed out (count reaches zero before being reset or disabled).
- Bit 0 General timer 1 timed out (count reaches zero before being reset or disabled).

During an interrupt service routine, the host can use this register to provide a binary timer value to one of the timers (Sync modes only), as detailed in the Modem End of Interrupt register. The host can only load one of the two timers in each interrupt service routine.

9.5.4.4 Modem End of Interrupt Register (MEOIR)

Register Name: MEOIR				Intel Hex Address: x'85			
Register Description: Modem End of Interrupt Register				Motorola Hex Address: x'86			
Default Value: x'00							
Access: Byte Write Only							
Bit 7	Bit 6	Bit 5	Bit 4	Bit 3	Bit 2	Bit 1	Bit 0
0	0	SetTm2	SetTm1	0	0	0	0

- Bits 7:6 Reserved – *must be zero*.
- Bit 5 Set general timer 2 (Synchronous modes only)
0 = do not set general timer 2.
1 = load the value, provided in MISR, to general timer 2.
- Bit 4 Set general timer 1 (Synchronous modes only)
0 = do not set general timer 1.
1 = load the value, provided in MISR, to the high byte of general timer 1.

At the end of an interrupt service routine, the user can set the timer by setting a timer value in the Modem Interrupt Status register. When the timer reaches '0', the CD2481 generates a modem/timer group interrupt to the host.
- Bits 3:0 Reserved – *must be zero*.

9.6 DMA Registers

9.6.1 DMA Mode Register (DMR)

Register Name: DMR				Intel Hex Address: x'F4			
Register Description: DMA Mode Register				Motorola Hex Address: x'F6			
Default Value: x'00							
Access: Byte Write Only							
Bit 7	Bit 6	Bit 5	Bit 4	Bit 3	Bit 2	Bit 1	Bit 0
EnSync	0	0	0	ByteDMA	0	0	0

This register is write only. No error occurs if the register is read, but the read value is not consistent.

Bits 7 Internal DTACK synchronization enable. If external synchronization of DTACK with BUSCLK is not provided, an internal synchronization can be enabled by setting this bit.

Bits 6:4 Reserved – *must be zero*.

Bit 3 Byte DMA
 0 = The CD2481 attempts to perform 16-bit data transfers whenever possible, and 8-bit data transfers only when necessary (when only one byte is available or there are odd address boundaries).
 1 = The CD2481 always performs 8-bit DMA transfers, the position of the data on the bus still follows the normal rules relating to the BYTESWAP pin.

Bits 2:0 Reserved – *must be zero*.

9.6.2 Bus Error Retry Count (BERCNT)

Register Name: BERCNT				Intel Hex Address: x'8D			
Register Description: Bus Error Retry Count Register				Motorola Hex Address: x'8E			
Default Value: x'00							
Access: Byte Read/Write							
Bit 7	Bit 6	Bit 5	Bit 4	Bit 3	Bit 2	Bit 1	Bit 0
Binary Value							

When this register is programmed to zero, any bus error causes a receive/transmit interrupt to be generated and DMA operations suspended on the buffer in error until the interrupt is processed by the host CPU.

When this register contains a non-zero value and when a bus error occurs, the CD2481 decrements the register value by one and retries the same DMA operation. If the value reaches zero, the next bus error causes an interrupt; at that time a new count can be loaded by the host CPU. This is a

global register used by all channels. It is not automatically reloaded by the CD2481. If the host CPU wishes to avoid bus error interrupts, it should periodically reload BERCNT to prevent it from reaching a zero value.

9.6.3 DMA Buffer Status (DMABSTS)

Register Name: DMABSTS				Intel Hex Address: x'1A			
Register Description: DMA Buffer Status Register				Motorola Hex Address: x'19			
Default Value: x'00							
Access: Byte Read Only							
Bit 7	Bit 6	Bit 5	Bit 4	Bit 3	Bit 2	Bit 1	Bit 0
TDAlign	RstApd	CrtBuf	Append	Ntbuf	Tbusy	Nrbuf	Rbusy

When CD2481 requires an external buffer for DMA transfer, it checks Ntbuf/Nrbuf bits to decide which buffer to use. Note that it only checks the status of the buffer indicated by Ntbuf and Nrbuf; if Ntbuf/Nrbuf point to buffer A, but buffer A is not available (as indicated by 2481Own), it will not check to see if buffer B is available, even if 2481Own is set for buffer B. Once CD2481 starts using the buffer, it toggles Ntbuf/Nrbuf bits, and sets Tbusy/Rbusy bits. Ntbuf and Nrbuf bits are set to Buffer A at system initialization.

- Bit 7 This status bit is used internally to manage data alignment in the transmit FIFO.
- Bit 6 Reset Append mode is set after the terminate append buffer command in STCR has been recognized, and is cleared after the remaining data has been flushed from the buffer.
- Bit 5 Current transmit buffer is used internally to mark the actual buffer in use.
- Bit 4 Append (only Buffer A can be used as an append buffer)
Transmit append buffer usage indicator
0 = Append buffer is not in use.
1 = Append buffer is in use.
- Bit 3 Ntbuf
Next transmit buffer
0 = Buffer A is the next transmit buffer.
1 = Buffer B is the next transmit buffer.

This bit is toggled when transmission starts from a buffer, that is, when data is first read from Buffer A, the bit is set to indicate that Buffer B is next.
- Bit 2 Tbusy
Current transmit buffer is in use
0 = No buffer is in use.
1 = Current transmit buffer is in use.
- Bit 1 Nrbuf
Next receive buffer
0 = Buffer A is the next receive buffer.
1 = Buffer B is the next receive buffer.

This bit is toggled when receive data is first written to a buffer, that is, when data is first written to Buffer A, the bit is set to indicate Buffer B is next.

Bit 0 Rbusy
 Current receive buffer is in use
 0 = No buffer is in use.
 1 = Current receive buffer is in use.

9.6.4 DMA Receive Registers

9.6.4.1 A Receive Buffer Address Lower (ARBADRL)

Register Name: ARBADRL						Intel Hex Address: x'40	
Register Description: Receive Buffer 'A' 32-bit Address, lower word						Motorola Hex Address: x'42	
Default Value: x'0000							
Access: Word Read/Write							
Bit 15	Bit 14	Bit 13	Bit 12	Bit 11	Bit 10	Bit 9	Bit 8
Binary Address Value, 32-bit Address bits 15 - 8							
Bit 7	Bit 6	Bit 5	Bit 4	Bit 3	Bit 2	Bit 1	Bit 0
Binary Address Value, 32-bit Address bits 7 - 0							

9.6.4.2 A Receive Buffer Address Upper (ARBADRU)

Register Name: ARBADRU						Intel Hex Address: x'42	
Register Description: Receive Buffer 'A' 32-bit Address, upper word						Motorola Hex Address: x'40	
Default Value: x'0000							
Access: Word Read/Write							
Bit 15	Bit 14	Bit 13	Bit 12	Bit 11	Bit 10	Bit 9	Bit 8
Binary Address Value, 32-bit Address bits 23 - 16							
Bit 7	Bit 6	Bit 5	Bit 4	Bit 3	Bit 2	Bit 1	Bit 0
Binary Address Value, 32-bit Address bits 31 - 24							

9.6.4.3 B Receive Buffer Address Lower (BRBADRL)

Register Name: BRBADRL						Intel Hex Address: x'44	
Register Description: Receive Buffer 'B' 32-bit Address, lower word						Motorola Hex Address: x'46	
Default Value: x'0000							
Access: Word Read/Write							
Bit 15	Bit 14	Bit 13	Bit 12	Bit 11	Bit 10	Bit 9	Bit 8
Binary Address Value, 32-bit Address, bits 15 - 8							
Bit 7	Bit 6	Bit 5	Bit 4	Bit 3	Bit 2	Bit 1	Bit 0
Binary Address Value, 32-bit Address, bits 7 - 0							

9.6.4.4 B Receive Buffer Address Upper (BRBADRU)

Register Name: BRBADRU						Intel Hex Address: x'46	
Register Description: Receive Buffer 'B' 32-bit Address, upper word						Motorola Hex Address: x'44	
Default Value: x'0000							
Access: Word Read/Write							
Bit 15	Bit 14	Bit 13	Bit 12	Bit 11	Bit 10	Bit 9	Bit 8
Binary Address Value, 32-bit Address, bits 23 - 16							
Bit 7	Bit 6	Bit 5	Bit 4	Bit 3	Bit 2	Bit 1	Bit 0
Binary Address Value, 32-bit Address, bits 31 - 24							

The ARBADRU/L and BRBADRU/L registers contain the start addresses of two external buffers that are used by the CD2481 to store the next two receive data blocks. They are written to by the host and copied internally to control the data transfer to the memory.

9.6.4.5 A Buffer Receive Byte Count (ARBCNT)

Register Name: ARBCNT						Intel Hex Address: x'48	
Register Description: Receive Buffer 'A' Byte Count						Motorola Hex Address: x'4A	
Default Value: x'0000							
Access: Word Read/Write							
Bit 15	Bit 14	Bit 13	Bit 12	Bit 11	Bit 10	Bit 9	Bit 8
Binary Count Value, 16-bit Count bits 15 - 8							
Bit 7	Bit 6	Bit 5	Bit 4	Bit 3	Bit 2	Bit 1	Bit 0
Binary Count Value, 16-bit Count, bits 7 - 0							

9.6.4.6 B Buffer Receive Byte Count (BRBCNT)

Register Name: BRBCNT						Intel Hex Address: x'4A	
Register Description: Receive Buffer 'B' Byte Count						Motorola Hex Address: x'48	
Default Value: x'0000							
Access: Word Read/Write							
Bit 15	Bit 14	Bit 13	Bit 12	Bit 11	Bit 10	Bit 9	Bit 8
Binary Count Value, 16-bit Count, bits 15 - 8							
Bit 7	Bit 6	Bit 5	Bit 4	Bit 3	Bit 2	Bit 1	Bit 0
Binary Count Value, 16-bit Count bits 7 - 0							

These registers contain the number of bytes stored in the external data buffers by the CD2481. The count is updated after a block of data is moved to memory and when the buffer is terminated. As initially written by the host, the register contains the number of bytes the buffer can hold.

9.6.4.7 A Receive Buffer Status (ARBSTS)

Register Name: ARBSTS						Intel Hex Address: x'4C	
Register Description: Receive Buffer 'A' Status						Motorola Hex Address: x'4F	
Default Value: x'00							
Access: Byte Read/Write							
Bit 7	Bit 6	Bit 5	Bit 4	Bit 3	Bit 2	Bit 1	Bit 0
Berr	EOF	EOB	0	0	0	0	2481own

9.6.4.8 B Receive Buffer Status (BRBSTS)

Register Name: BRBSTS						Intel Hex Address: x'4D	
Register Description: Receive Buffer 'B' Status						Motorola Hex Address: x'4E	
Default Value: x'00							
Access: Byte Read/Write							
Bit 7	Bit 6	Bit 5	Bit 4	Bit 3	Bit 2	Bit 1	Bit 0
Berr	EOF	EOB	0	0	0	0	2481own

These registers contain the current status of associated receive buffers and enable the buffers to be passed between the host and CD2481. Status bits are defined as follows:

- Bit 7 Bus error (set by the CD2481 and cleared by the host CPU)
0 = No bus error
1 = Bus error occurred on the last transfer; the suspect address is available in RCBADR.
- Bit 6 End of frame (set by the CD2481 and cleared by the host CPU); sync modes only.
0 = This buffer does not terminate a frame.
1 = This buffer terminates a frame.
- Bit 5 Buffer complete (set by the CD2481 and cleared by the host CPU)
0 = Buffer not complete.
1 = Buffer complete.
- Bits 4:1 Reserved – *must be zero*.
- Bit 0 Ownership of the transfer buffer (set by the host CPU and cleared by the CD2481)
0 = Buffer not free to be used by CD2481.
1 = Buffer free to be used by CD2481.

When the Buffer Completed bit is set by the CD2481, the buffer is free for the host to process. (RBCNT information is updated to the number of bytes available in the buffer, and a new buffer can be allocated.)

9.6.4.9 Receive Current Buffer Address Lower (RCBADRL)

Register Name: RCBADRL						Intel Hex Address: x'3C	
Register Description: Current Receive Buffer Address, lower word						Motorola Hex Address: x'3E	
Default Value: x'0000							
Access: Word Read Only							
Bit 15	Bit 14	Bit 13	Bit 12	Bit 11	Bit 10	Bit 9	Bit 8
Binary Address Value, 32-bit Address, bits 15 - 8							
Bit 7	Bit 6	Bit 5	Bit 4	Bit 3	Bit 2	Bit 1	Bit 0
Binary Address Value, 32-bit Address, bits 7 - 0							

9.6.4.10 Receive Current Buffer Address Upper (RCBADRU)

Register Name: RCBADRU						Intel Hex Address: x'3E	
Register Description: Current Receive Buffer Address, upper word						Motorola Hex Address: x'3C	
Default Value: x'0000							
Access: Word Read Only							
Bit 15	Bit 14	Bit 13	Bit 12	Bit 11	Bit 10	Bit 9	Bit 8
Binary Address Value, 32-bit Address, bits 31 - 24							
Bit 7	Bit 6	Bit 5	Bit 4	Bit 3	Bit 2	Bit 1	Bit 0
Binary Address Value, 32-bit Address, bits 23 - 16							

These registers contain the address of the current DMA buffer being used for receive data, updated at the end of receive data transfers. These registers are for the private use of the CD2481 to manage DMA transfers. In Asynchronous mode, the host can read this register during a receive exception interrupt to determine how much data is in the buffer. The address is the location of the next character to be transferred to the buffer. The host needs that information to process newly arrived data in the buffer if it is being used in the Append mode, and the data time-out has occurred. It is also needed if an exception has occurred, and a gap is to be left in the FIFO for the insertion of status information by the host. In the case of a bus error during receive data transfer, this register provides the start address of the transfer causing the bus error.



9.6.5 DMA Transmit Registers

9.6.5.1 A Transmit Buffer Address Lower (ATBADRL)

Register Name: ATBADRL						Intel Hex Address: x'50	
Register Description: Transmit Buffer 'A' 32-bit Address, lower word						Motorola Hex Address: x'52	
Default Value: x'0000							
Access: Word Read/Write							
Bit 15	Bit 14	Bit 13	Bit 12	Bit 11	Bit 10	Bit 9	Bit 8
Binary Address Value, 32-bit Address, bits 15 - 8							
Bit 7	Bit 6	Bit 5	Bit 4	Bit 3	Bit 2	Bit 1	Bit 0
Binary Address Value, 32-bit Address, bits 7 - 0							

9.6.5.2 A Transmit Buffer Address Upper (ATBADRU)

Register Name: ATBADRU						Intel Hex Address: x'52	
Register Description: Transmit Buffer 'A' 32-bit Address, upper word						Motorola Hex Address: x'50	
Default Value: x'0000							
Access: Word Read/Write							
Bit 15	Bit 14	Bit 13	Bit 12	Bit 11	Bit 10	Bit 9	Bit 8
Binary Address Value, 32-bit Address, bits 23 - 16							
Bit 7	Bit 6	Bit 5	Bit 4	Bit 3	Bit 2	Bit 1	Bit 0
Binary Address Value, 32-bit Address, bits 31 - 24							

9.6.5.3 B Transmit Buffer Address Lower (BTBADRL)

Register Name: BTBADRL						Intel Hex Address: x'54	
Register Description: Transmit Buffer 'B' 32-bit Address, lower word						Motorola Hex Address: x'56	
Default Value: x'0000							
Access: Word Read/Write							
Bit 15	Bit 14	Bit 13	Bit 12	Bit 11	Bit 10	Bit 9	Bit 8
Binary Address Value, 32-bit Address, bits 15 - 8							
Bit 7	Bit 6	Bit 5	Bit 4	Bit 3	Bit 2	Bit 1	Bit 0
Binary Address Value, 32-bit Address, bits 7 - 0							

9.6.5.4 B Transmit Buffer Address Upper (BTBADRU)

Register Name: BTBADRU						Intel Hex Address: x'56	
Register Description: Transmit Buffer 'B' 32-bit Address, upper word						Motorola Hex Address: x'54	
Default Value: x'0000							
Access: Word Read/Write							
Bit 15	Bit 14	Bit 13	Bit 12	Bit 11	Bit 10	Bit 9	Bit 8
Binary Address Value, 32-bit Address, bits 23 - 16							
Bit 7	Bit 6	Bit 5	Bit 4	Bit 3	Bit 2	Bit 1	Bit 0
Binary Address Value, 32-bit Address, bits 31 - 24							

These registers contain the start addresses of two external buffers that are used by the CD2481 to transmit the next data blocks. They are written to by the host and copied internally to control the data transfer from the memory to the CD2481 FIFO.

9.6.5.5 A Buffer Transmit Byte Count (ATBCNT)

Register Name: ATBCNT						Intel Hex Address: x'58	
Register Description: Transmit Buffer 'A' Byte Count						Motorola Hex Address: x'5A	
Default Value: x'0000							
Access: Word Read/Write							
Bit 15	Bit 14	Bit 13	Bit 12	Bit 11	Bit 10	Bit 9	Bit 8
Binary Count Value, 16-bit Count bits 15 - 8							
Bit 7	Bit 6	Bit 5	Bit 4	Bit 3	Bit 2	Bit 1	Bit 0
Binary Count Value, 16-bit Count, bits 7 - 0							

9.6.5.6 B Buffer Transmit Byte Count (BTBCNT)

Register Name: BTBCNT						Intel Hex Address: x'5A	
Register Description: Transmit Buffer 'B' Byte Count						Motorola Hex Address: x'58	
Default Value: x'0000							
Access: Word Read/Write							
Bit 15	Bit 14	Bit 13	Bit 12	Bit 11	Bit 10	Bit 9	Bit 8
Binary Count Value, 16-bit Count, bits 15 - 8							
Bit 7	Bit 6	Bit 5	Bit 4	Bit 3	Bit 2	Bit 1	Bit 0
Binary Count Value, 16-bit Count bits 7 - 0							

These registers contain the count of the bytes in the buffers to be transmitted.

9.6.5.7 A Transmit Buffer Status (ATBSTS) –Async Mode

Register Name: ATBSTS						Intel Hex Address: x'5C	
Register Description: Transmit Buffer 'A' Status Register						Motorola Hex Address: x'5F	
Default Value: x'00							
Access: Byte Read/Write							
Bit 7	Bit 6	Bit 5	Bit 4	Bit 3	Bit 2	Bit 1	Bit 0
Berr	EOF	EOB	0	Append	0	INTR	2481own

9.6.5.8 B Transmit Buffer Status (BTBSTS) –Async Mode

Register Name: BTBSTS						Intel Hex Address: x'5D	
Register Description: Transmit Buffer 'B' Status Register						Motorola Hex Address: x'5E	
Default Value: x'00							
Access: Byte Read/Write							
Bit 7	Bit 6	Bit 5	Bit 4	Bit 3	Bit 2	Bit 1	Bit 0
Berr	EOF	EOB	0	0	0	INTR	2481own

These registers contain the status of the associated transmit buffer, and enables successive buffers to be passed between the host and the CD2481. Status bits within the register are defined as:

- Bit 7 Bus error (set by the CD2481 and cleared by the host CPU)
0 = no bus error
1 = bus error occurred on the last transfer; the suspect address is available in TCBADR
- Bit 6 End of frame (set and cleared by host CPU)
0 = this buffer is not the last in frame/block
1 = this buffer is the last in frame/block
- Bit 5 End of a transmit buffer has been reached. Used only for DMA supported transfer. The end of one of the host supplied transmit buffers has been reached. This bit is set by the CD2481 and cleared by the host CPU.
- Bit 4 Reserved – *must be zero*.
- Bit 3 Append (Buffer A only, buffer B must be zero; set and cleared by the host CPU)
0 = no data is appended to the buffer
1 = data can be appended to buffer after Tx started
- Bit 2 Reserved – *must be zero*.
- Bit 1 Interrupt
0 = no interrupt required after the buffer is sent
1 = interrupt required after the buffer is sent
- Bit 0 Ownership of the transfer buffer (set by the host CPU and cleared by the CD2481)
0 = buffer not ready to be used by the CD2481
1 = buffer is ready for the CD2481 to transmit

To start transmission of a buffer, the host must set the ATBADR/BTBADR (Transmit Buffer Address) and ATBCNT/BTBCNT (Transmit Buffer Count) registers, and then set the 2481OWN bit. If the CD2481 is to generate and send the CRC for the frame, the CRC bit in COR1 must be set. If the buffer contains the end of a frame, the EOF bit must also be set. When the buffer has been sent, the EOB bit is set by the CD2481, and 2481OWN is reset, allowing a new buffer to be allocated.

Setting the Append bit allows data to be added to the buffer after transmission has begun. In this mode, the host sets ATADR and ATCNT as normal, but when new data is appended to the buffer, the ATBCNT/BTBCNT (Transmit Buffer Count) can be updated. When the A buffer is used in

Append mode, the CD2481 does not set the EOB bit. When the host has completed use of the buffer, it must issue the append complete command through STCR. The CD2481, upon transmitting the last characters from the buffer, sets EOB, thus allowing the host to allocate a new transmit buffer.

9.6.5.9 A Transmit Buffer Status (ATBSTS) –HDLC / Bisync / X.21 Modes

Register Name: ATBSTS						Intel Hex Address: x'5C	
Register Description: Transmit Buffer 'A' Status Register						Motorola Hex Address: x'5F	
Default Value: x'00							
Access: Byte Read/Write							
Bit 7	Bit 6	Bit 5	Bit 4	Bit 3	Bit 2	Bit 1	Bit 0
Berr	EOF	EOB	UE	0	0	INTR	2481own

9.6.5.10 B Transmit Buffer Status (BTBSTS) –HDLC / Bisync / X.21 Modes

Register Name: BTBSTS						Intel Hex Address: x'5D	
Register Description: Transmit Buffer 'B' Status Register						Motorola Hex Address: x'5E	
Default Value: x'00							
Access: Byte Read/Write							
Bit 7	Bit 6	Bit 5	Bit 4	Bit 3	Bit 2	Bit 1	Bit 0
Berr	EOF	EOB	UE	0	0	INTR	2481own

These registers contain the status of the associated transmit buffer, and enables successive buffers to be passed between the host and the CD2481. Status bits within the register are defined as:

- Bit 7 Bus error (set by the CD2481 and cleared by the host CPU)
0 = no bus error
1 = bus error occurred on the last transfer; the suspect address is available in TCBADR
- Bit 6 End of frame (set and cleared by host CPU)
0 = this buffer is not the last in frame/block
1 = this buffer is the last in frame/block
- Bit 5 End of a transmit buffer has been reached. Used only for DMA supported transfer. The end of one of the host supplied transmit buffers has been reached. This bit is set by the CD2481 and cleared by the host CPU.
- Bit 4 Underrun – Transmit underrun occurred as the buffer was not available, and it applies to this buffer.
- Bit 3:2 Reserved – *must be zero.*
- Bit 1 Interrupt
0 = no interrupt required after the buffer is sent
1 = interrupt required after the buffer is sent

Bit 0 Ownership of the transfer buffer (set by the host CPU and cleared by the CD2481)
 0 = buffer not ready to be used by the CD2481
 1 = buffer is ready for the CD2481 to transmit

9.6.5.11 A Transmit Buffer Status (ATBSTS) –Async-HDLC/PPP Mode

Register Name: ATBSTS Register Description: Transmit Buffer 'A' Status Register Default Value: x'00 Access: Byte Read/Write						Intel Hex Address: x'5C Motorola Hex Address: x'5F	
Bit 7	Bit 6	Bit 5	Bit 4	Bit 3	Bit 2	Bit 1	Bit 0
Berr	EOF	EOB	0	0	map32	INTR	2481own

9.6.5.12 B Transmit Buffer Status (BTBSTS) –Async-HDLC/PPP Mode

Register Name: BTBSTS Register Description: Transmit Buffer 'B' Status Register Default Value: x'00 Access: Byte Read/Write						Intel Hex Address: x'5D Motorola Hex Address: x'5E	
Bit 7	Bit 6	Bit 5	Bit 4	Bit 3	Bit 2	Bit 1	Bit 0
Berr	EOF	EOB	0	0	map32	INTR	2481own

Bit 7 Berr – Bus error (set by the CD2481, and cleared by the host)
 0 = No bus error
 1 = Bus error was detected on the last transfer

Bit 6 EOF – End of frame (set and cleared by the host)
 0 = This buffer is not the last in frame/block.
 1 = This buffer is the last in frame/block.

Bit 5 EOB – The end of a transmit buffer (set by the CD2481, and cleared by the host).
 The end of a host supplied transmit buffer has been reached.

Bits 4:3 Reserved – *must be zero*.

Bit 2 map32 – Map all transmit characters from 00–1F (set and cleared by the host)
 0 = Use the normal TXACCM map.
 1 = Map all characters in the range from 00–1F.

Bit 1 INTR – Interrupt
 0 = No interrupt required after the buffer is transmitted.
 1 = Interrupt required after the buffer is transmitted.

Bit 0 2481own – Ownership of the transmit buffer (set by the host and cleared by the CD2481)

0 = Buffer is owned by the host, and not ready for use by the CD2481.
 1 = Buffer is owned by the CD2481, and is ready for use by the CD2481.

9.6.5.13 A Transmit Buffer Status (ATBSTS) –SLIP/MNP4 Mode

Register Name: ATBSTS						Intel Hex Address: x'5C	
Register Description: Transmit Buffer 'A' Status Register						Motorola Hex Address: x'5F	
Default Value: x'00							
Access: Byte Read/Write							
Bit 7	Bit 6	Bit 5	Bit 4	Bit 3	Bit 2	Bit 1	Bit 0
Berr	EOF	EOB	0	0	0	INTR	2481own

9.6.5.14 B Transmit Buffer Status (BTBSTS) – SLIP/MNP4 Mode

Register Name: BTBSTS						Intel Hex Address: x'5D	
Register Description: Transmit Buffer 'B' Status Register						Motorola Hex Address: x'5E	
Default Value: x'00							
Access: Byte Read/Write							
Bit 7	Bit 6	Bit 5	Bit 4	Bit 3	Bit 2	Bit 1	Bit 0
Berr	EOF	EOB	0	0	0	INTR	2481own

- Bit 7 Berr – Bus error (set by the CD2481, and cleared by the host)
 0 = No bus error.
 1 = Bus error was detected on the last transfer.

- Bit 6 EOF – End of Frame (set and cleared by the host)
 0 = This buffer is not the last in frame/block.
 1 = This buffer is the last in frame/block.

- Bit 5 EOB – The end of a transmit buffer has been reached
 (set by the CD2481, and cleared by the host)
 The end of a host supplied transmit buffer has been reached.

- Bits 4:2 Reserved – *must be zero*.

- Bit 1 INTR – Interrupt
 0 = No interrupt required after the buffer is transmitted.
 1 = Interrupt required after the buffer is transmitted.

- Bit 0 2481own – Ownership of the transmit buffer (set by the host and cleared by the CD2481)
 0 = Buffer is owned by the host, and not ready for use by the CD2481.
 1 = Buffer is owned by the CD2481, and is ready for use by the CD2481.

9.6.5.15 Transmit Current Buffer Address Lower (TCBADRL)

Register Name: TCBADRL						Intel Hex Address: x'38	
Register Description: Current Transmit Buffer Address, lower word						Motorola Hex Address: x'3A	
Default Value: x'0000							
Access: Word Read Only							
Bit 15	Bit 14	Bit 13	Bit 12	Bit 11	Bit 10	Bit 9	Bit 8
Binary Address Value, 32-bit Address, bits 15 - 8							
Bit 7	Bit 6	Bit 5	Bit 4	Bit 3	Bit 2	Bit 1	Bit 0
Binary Address Value, 32-bit Address, bits 7 - 0							

9.6.5.16 Transmit Current Buffer Address Upper (TCBADRU)

Register Name: TCBADRU						Intel Hex Address: x'3A	
Register Description: Current Transmit Buffer Address, upper word						Motorola Hex Address: x'38	
Default Value: x'0000							
Access: Word Read Only							
Bit 15	Bit 14	Bit 13	Bit 12	Bit 11	Bit 10	Bit 9	Bit 8
Binary Address Value, 32-bit Address, bits 31 - 24							
Bit 7	Bit 6	Bit 5	Bit 4	Bit 3	Bit 2	Bit 1	Bit 0
Binary Address Value, 32-bit Address, bits 23 - 16							

These registers contain the address of the current DMA buffer being used for transmit data, updated at the end of transmit data transfers. In the case of a bus error during transmit data transfer, this register contains the start address of the transfer causing the bus error.

9.7 Timer Registers

9.7.1 Timer Period Register (TPR)

Register Name: TPR						Intel Hex Address: x'D8	
Register Description: Timer Period Register						Motorola Hex Address: x'DA	
Default Value: x'FF							
Access: Byte Read/Write							
<i>Bit 7</i>	<i>Bit 6</i>	<i>Bit 5</i>	<i>Bit 4</i>	<i>Bit 3</i>	<i>Bit 2</i>	<i>Bit 1</i>	<i>Bit 0</i>
Binary Value							

This register provides the initialization value for the timer prescaler that is itself clocked by a prescaled clock equal to system clock/2048. The timer prescaler establishes the clock for the various on-chip timers (including RTPR, TTR, and the general timers available to the host in the Synchronous modes). The minimum value loaded in this register to maintain accuracy in the timer is 0A hex.

9.7.2 Receive Time-Out Period Register (RTPR) – Async Modes Only

Register Name: RTPR						Intel Hex Address: x'26	
Register Description: Receive Time-Out Period Register, 16-bit						Motorola Hex Address: x'24	
Default Value: x'0000							
Access: Word Read/Write							
<i>Bit 15</i>	<i>Bit 14</i>	<i>Bit 13</i>	<i>Bit 12</i>	<i>Bit 11</i>	<i>Bit 10</i>	<i>Bit 9</i>	<i>Bit 8</i>
Binary Value, bits 15 - 8							
<i>Bit 7</i>	<i>Bit 6</i>	<i>Bit 5</i>	<i>Bit 4</i>	<i>Bit 3</i>	<i>Bit 2</i>	<i>Bit 1</i>	<i>Bit 0</i>
Binary Value, bits 7 - 0							

9.7.2.1 Receive Time-Out Period Register low (RTPRI) – Async Modes Only

Register Name: RTPRI						Intel Hex Address: x'26	
Register Description: Receive Time-Out Period Register, Low Byte						Motorola Hex Address: x'25	
Default Value: x'00							
Access: Byte Read/Write, ASYNC Mode Only							
<i>Bit 7</i>	<i>Bit 6</i>	<i>Bit 5</i>	<i>Bit 4</i>	<i>Bit 3</i>	<i>Bit 2</i>	<i>Bit 1</i>	<i>Bit 0</i>
Binary Value, bits 7 - 0							

9.7.2.2 Receive Time-Out Period Register high (RTPRh) – Async Modes Only

Register Name: RTPRh						Intel Hex Address: x'27	
Register Description: Receive Time-Out Period Register, High Byte						Motorola Hex Address: x'24	
Default Value: x'00							
Access: Byte Read/Write, ASYNC Mode Only							
Bit 7	Bit 6	Bit 5	Bit 4	Bit 3	Bit 2	Bit 1	Bit 0
Binary Value, bits 15 - 8							

Receive Time-Out Period register (16-bits)

This value sets the receive data time-out period. As each character is moved to the receive FIFO or the last data is transferred from the FIFO to the host, the receive timer (an internal timer) is reloaded with the Receive Time-Out Period register. The receive timer is decremented on each 'tick' of the prescaler counter, whose period is controlled by TPR. If the receive timer reaches zero, it causes a receive data interrupt.

9.7.3 General Timer 1 (GT1) – Sync Modes Only

Register Name: GT1						Intel Hex Address: x'28	
Register Description: General Timer 1						Motorola Hex Address: x'2A	
Default Value: x'00							
Access: Word Read/Write							
Bit 15	Bit 14	Bit 13	Bit 12	Bit 11	Bit 10	Bit 9	Bit 8
Binary Value, bits 15 - 8							
Bit 7	Bit 6	Bit 5	Bit 4	Bit 3	Bit 2	Bit 1	Bit 0
Binary Value, bits 7 - 0							

9.7.3.1 General Timer 1 low (GT1l) – Sync Modes Only

Register Name: GT1l						Intel Hex Address: x'28	
Register Description: General Timer 1, high byte						Motorola Hex Address: x'2B	
Default Value: x'00							
Access: Byte Read/Write							
Bit 7	Bit 6	Bit 5	Bit 4	Bit 3	Bit 2	Bit 1	Bit 0
Binary Value, bits 7 - 0							

9.7.3.2 General Timer 1 high (GT1h) – Sync Modes Only

Register Name: GT1h						Intel Hex Address: x'29	
Register Description: General Timer 1, low byte						Motorola Hex Address: x'2A	
Default Value: x'00							
Access: Byte Read/Write							
<i>Bit 7</i>	<i>Bit 6</i>	<i>Bit 5</i>	<i>Bit 4</i>	<i>Bit 3</i>	<i>Bit 2</i>	<i>Bit 1</i>	<i>Bit 0</i>
Binary Value, bits 15 - 8							

9.7.4 General Timer 2 (GT2) – Sync Modes Only

Register Name: GT2						Intel Hex Address: x'2A	
Register Description: General Timer 2						Motorola Hex Address: x'29	
Default Value: x'00							
Access: Byte Read/Write							
<i>Bit 7</i>	<i>Bit 6</i>	<i>Bit 5</i>	<i>Bit 4</i>	<i>Bit 3</i>	<i>Bit 2</i>	<i>Bit 1</i>	<i>Bit 0</i>
Binary Value							

This 16-bit timer can be started by the user whenever it is inactive by writing a 16-bit time-out value to the register. When non-zero, it is decremented on each prescaler clock 'tick'. When it reaches zero, a modem/timer group interrupt is generated to the host. The timer can be disabled by the Channel Command register. In addition, during a receive or transmit interrupt, the user can reload a running timer (high byte only) by providing a reload value in the Interrupt Status register and a reload timer command in the End of Interrupt register for the interrupt being serviced. Only one general timer can be restarted this way in a single-interrupt routine.

This 8-bit timer can be started by the user whenever it is inactive by writing an 8-bit time-out value to the Timer register. When non-zero, it is decremented on each prescaler clock 'tick'. When it reaches zero, a modem/timer group interrupt is generated to the host. The timer can be disabled by the Channel Command register if the timer's current value is greater than one. In addition, during a receive or transmit interrupt, the user can reload a running timer by providing a reload value in the Interrupt Status register and a reload timer command in the End of Interrupt register for the interrupt being serviced. Only one general timer can be restarted this way in a single-interrupt routine.



9.7.5 Transmit Timer Register (TTR) – Async Modes Only

Register Name: TTR				Intel Hex Address: x'2A			
Register Description: Transmit Timer Register				Motorola Hex Address: x'29			
Default Value: x'00							
Access: Byte Read Only							
<i>Bit 7</i>	<i>Bit 6</i>	<i>Bit 5</i>	<i>Bit 4</i>	<i>Bit 3</i>	<i>Bit 2</i>	<i>Bit 1</i>	<i>Bit 0</i>
Binary Value							

This Asynchronous mode timer is managed by the CD2481 to implement embedded transmit delays when that option is used by the host (see description of Channel Option Register 2). It should not be modified by the host under any circumstances.

10.0 Electrical Specifications

Note: Verify with your local sales office that you have the latest datasheet before finalizing a design.

10.1 Absolute Maximum Ratings (Revision B at 35 MHz)

Operating ambient temperature (T_A).....	0°C to 70°C
Storage temperature	-65°C to 150°C
All voltages with respect to ground	-0.5 V to $V_{CC} + 0.5$ V (volts)
Supply voltage (V_{CC}).....	+7.0 V
Power dissipation.....	0.25 W (watt)

Note: Stresses above those listed under Absolute Maximum Ratings can cause permanent damage to the device. These are stress ratings only and functional operation of the device at these or any conditions above those indicated in the operational sections of this specification is not implied. Exposure to absolute maximum rating conditions for extended periods can affect device reliability.

10.2 DC Electrical Characteristics (Revision B at 35 MHz)

(@ $V_{CC} = 5$ V \pm 5%, $T_A = 0^\circ\text{C}$ to 70°C)

Symbol	Parameter	MIN	MAX	Units	Test Conditions
V_{IL}	Input low voltage	-0.5	0.8	V	
V_{IH}	Input high voltage (all pins except CLK, RESET*, and BGIN*)	2.0	V_{CC}	V	
V_{IH}	Input high voltage for CLK, RESET*, and BGIN*	2.7	V_{CC}	V	
V_{OL}	Output low voltage	0.4		V	$I_{OL} = 10$ mA
V_{OH}	Output high voltage	2.4		V	$I_{OH} = -400$ μ A
I_{IL}	Input leakage current	-10	10	μ A	$0 < V_{IN} < V_{CC}$
I_{LL}	Data bus tristate leakage current	-10	10	μ A	$0 < V_{OUT} < V_{CC}$
I_{OC}	Open-drain output leakage	-10	10	μ A	$0 < V_{OUT} < V_{CC}$
I_{DD}	Power supply current		50	mA	CLK = 35 MHz
C_{IN}	Input capacitance		10	pF	
C_{OUT}	Output capacitance		10	pF	

10.3 AC Electrical Characteristics (Revision B at 35 MHz)

Symbol	Parameter (Sheet 1 of 2)	MIN	MAX
t_{PERIOD}	Period of CLK input (60 MHz maximum)	28.57	
t_1	CLK high to BUSCLK high		20
t_2	CLK high to BUSCLK low		20
Bus Arbitration			
t_{11}	CLK high to BGACK* tristate		25
t_{12}	BGIN* low to address valid ¹		40
t_{13}	Address hold after CLK high	0	
t_{14}	CLK high to address tristate		25
t_{15}	CLK high to ADLD* low		17
t_{16}	CLK high to ADLD* high		20
t_{17}	Address setup to ADLD* high	15	
t_{18}	CLK high to AEN*/DATEN*/DATDIR* high		25
t_{19}	CLK high to AEN*/DATEN*/DATDIR* tristate		25
t_{20}	CLK high to AEN*/DATEN*/DATDIR* low		25
DMA Read			
t_{21}	Data setup to CLK high	2	
t_{22}	Data hold after CLK high	15	
t_{23}	CLK high to address valid		30
t_{24}	CLK low to AS* low		20
t_{25}	CLK high to AS* high		20
t_{26}	CLK low to DS* low		20
t_{27}	CLK high to DS* high		20
t_{28}	DTACK* low setup to CLK high	10	
t_{29}	DTACK* high setup to CLK high (to avoid false termination)	50	
DMA Write			
t_{31}	CLK high to data valid		40
t_{32}	Data hold after CLK high	0	
t_{33}	CLK low to DS* low		20
t_{34}	CLK high to DS* high		20
t_{35}	DTACK* low setup to CLK high	10	
t_{36}	DTACK* high setup to CLK high (to avoid false termination)	50	
Host Read/Write			
t_{41}	DS* and CS* low setup to CLK high	7	
t_{44}	R/W* setup to CLK high	5	
t_{45}	CLK high to data valid		25

Symbol	Parameter (Sheet 2 of 2)	MIN	MAX
t_{46}	Data setup time to CLK high	5	
t_{47}	Data hold time after CLK high	15	
t_{48}	Address setup time to CLK high	5	
t_{49}	Address hold time after CLK high	15	
t_{50}	CLK high to DTACK* low (read cycle)		20
t_{51}	CLK high to DTACK* low (write cycle)		20
t_{52}	(CS* and DS*) low to DATEN*/DATDIR* low		25
t_{53}	DS* high to DATEN*/DATDIR* tristate		25
t_{54}	DS* high to data bus tristate		25
t_{55}	DS* high to DTACK* high-impedance		25
Interrupt Acknowledge			
t_{61}	CLK high to IACKIN*, DS* setup	17	
t_{63}	CLK high to data valid		25
t_{64}	Address setup to IACKIN* low	0	
t_{65}	Address hold after IACKIN* high	0	
t_{66}	CLK high to DTACK* low		20
t_{67}	(IACKIN* and DS*) low and BUSCLK high to DATEN* and DATDIR* low		40

1. This timing assumes the following conditions: BGACK* high, DTACK* high, DS* high, and BUSCLK high.

10.4 Absolute Maximum Ratings (Revisions B and D at 60 MHz)

Operating ambient temperature (T_A) 0°C to 70°C

Storage temperature -65°C to 150°C

All voltages with respect to ground -0.5 V to $V_{CC} + 0.5$ V (volts)

Supply voltage (V_{CC}) +7.0 V

Power dissipation 0.72 W (watt)

Note: Stresses above those listed under Absolute Maximum Ratings can cause permanent damage to the device. These are stress ratings only and functional operation of the device at these or any conditions above those indicated in the operational sections of this specification is not implied. Exposure to absolute maximum rating conditions for extended periods can affect device reliability.

10.5 DC Electrical Characteristics (Revisions B and D at 60 MHz)

(@ $V_{CC} = 5\text{ V} \pm 5\%$, $T_A = 0^\circ\text{C}$ to 70°C)

Symbol	Parameter	MIN	MAX	Units	Test Conditions
V_{IL}	Input low voltage	-0.5	0.8	V	
V_{IH}	Input high voltage (all pins except CLK, RESET*, and BGIN*)	2.0	V_{CC}	V	
V_{IH}	Input high voltage for CLK, RESET*, and BGIN*	2.7	V_{CC}	V	
V_{OL}	Output low voltage	0.4		V	$I_{OL} = 10\text{ mA}$
V_{OH}	Output high voltage	2.4		V	$I_{OH} = -400\text{ }\mu\text{A}$
I_{IL}	Input leakage current	-10	10	μA	$0 < V_{IN} < V_{CC}$
I_{LL}	Data bus tristate leakage current	-10	10	μA	$0 < V_{OUT} < V_{CC}$
I_{OC}	Open-drain output leakage	-10	10	μA	$0 < V_{OUT} < V_{CC}$
I_{DD}	Power supply current		130	mA	CLK = 60 MHz
C_{IN}	Input capacitance		7.5	pF	
C_{OUT}	Output capacitance		7.5	pF	

10.6 AC Electrical Characteristics (Revisions B and D at 60 MHz)

Symbol	Parameter (Sheet 1 of 2)	MIN	MAX
t_{PERIOD}	Period of CLK input (60 MHz maximum)	16.667	
t_{LOW}	CLK low phase (60/40 duty cycle, worst case)	6.667	10
t_{HIGH}	CLK high phase (60/40 duty cycle, worst case)	6.667	10
t_1	CLK high to BUSCLK high		17
t_2	CLK high to BUSCLK low		17
Bus Arbitration			
t_{11}	CLK high to BGACK* tristate		25
t_{12}	BGIN* low to address valid ¹		40
t_{13}	Address hold after CLK high	0	
t_{14}	CLK high to address tristate		20
t_{15}	CLK high to ADLD* low		13
t_{16}	CLK high to ADLD* high		16
t_{17}	Address setup to ADLD* high	15	
t_{18}	CLK high to AEN*/DATEN*/DATDIR* high		20
t_{19}	CLK high to AEN*/DATEN*/DATDIR* tristate		20
t_{20}	CLK high to AEN*/DATEN*/DATDIR* low		25
DMA Read			
t_{21}	Data setup to CLK high	2	
t_{22}	Data hold after CLK high	12	
t_{23}	CLK high to address valid		27
t_{24}	CLK low to AS* low		16
t_{25}	CLK high to AS* high		15
t_{26}	CLK low to DS* low		16
t_{27}	CLK high to DS* high		15
t_{28}	DTACK* low setup to CLK high	10	
t_{29}	DTACK* high setup to CLK high (to avoid false termination)	30	
DMA Write			
t_{31}	CLK high to data valid		40
t_{32}	Data hold after CLK high	0	
t_{33}	CLK low to DS* low		16
t_{34}	CLK high to DS* high		15
t_{35}	DTACK* low setup to CLK high	10	
t_{36}	DTACK* high setup to CLK high (to avoid false termination)	30	
Host Read/Write			
t_{41}	DS* and CS* low setup to CLK high	7	

Symbol	Parameter (Sheet 2 of 2)	MIN	MAX
t_{44}	R/W* setup to CLK high	5	
t_{45}	CLK high to data valid		25
t_{46}	Data setup time to CLK high	5	
t_{47}	Data hold time after CLK high	12	
t_{48}	Address setup time to CLK high	5	
t_{49}	Address hold time after CLK high	10	
t_{50}	CLK high to DTACK* low (read cycle)		17
t_{51}	CLK high to DTACK* low (write cycle)		17
t_{52}	(CS* and DS*) low to DATEN*/DATDIR* low		25
t_{53}	DS* high to DATEN*/DATDIR* tristate		25
t_{54}	DS* high to data bus tristate		17
t_{55}	DS* high to DTACK* high-impedance		17
Interrupt Acknowledge			
t_{61}	CLK high to IACKIN*, DS* setup	17	
t_{63}	CLK high to data valid		25
t_{64}	Address setup to IACKIN* low	0	
t_{65}	Address hold after IACKIN* high	0	
t_{66}	CLK high to DTACK* low		20
t_{67}	(IACKIN* and DS*) low and BUSCLK high to DATEN* and DATDIR* low		40

1. This timing assumes the following conditions: BGACK* high, DTACK* high, DS* high, and BUSCLK high.

Figure 21. CLK / BUSCLK / RESET* Timing Relationship

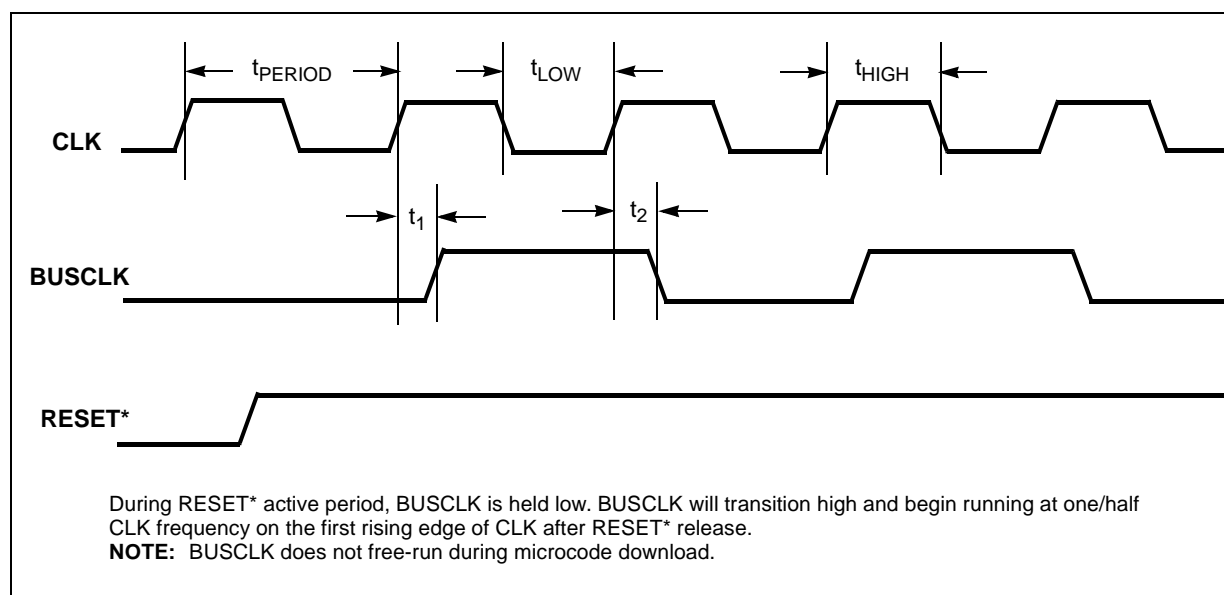

Figure 22. Slave Read Cycle Timing

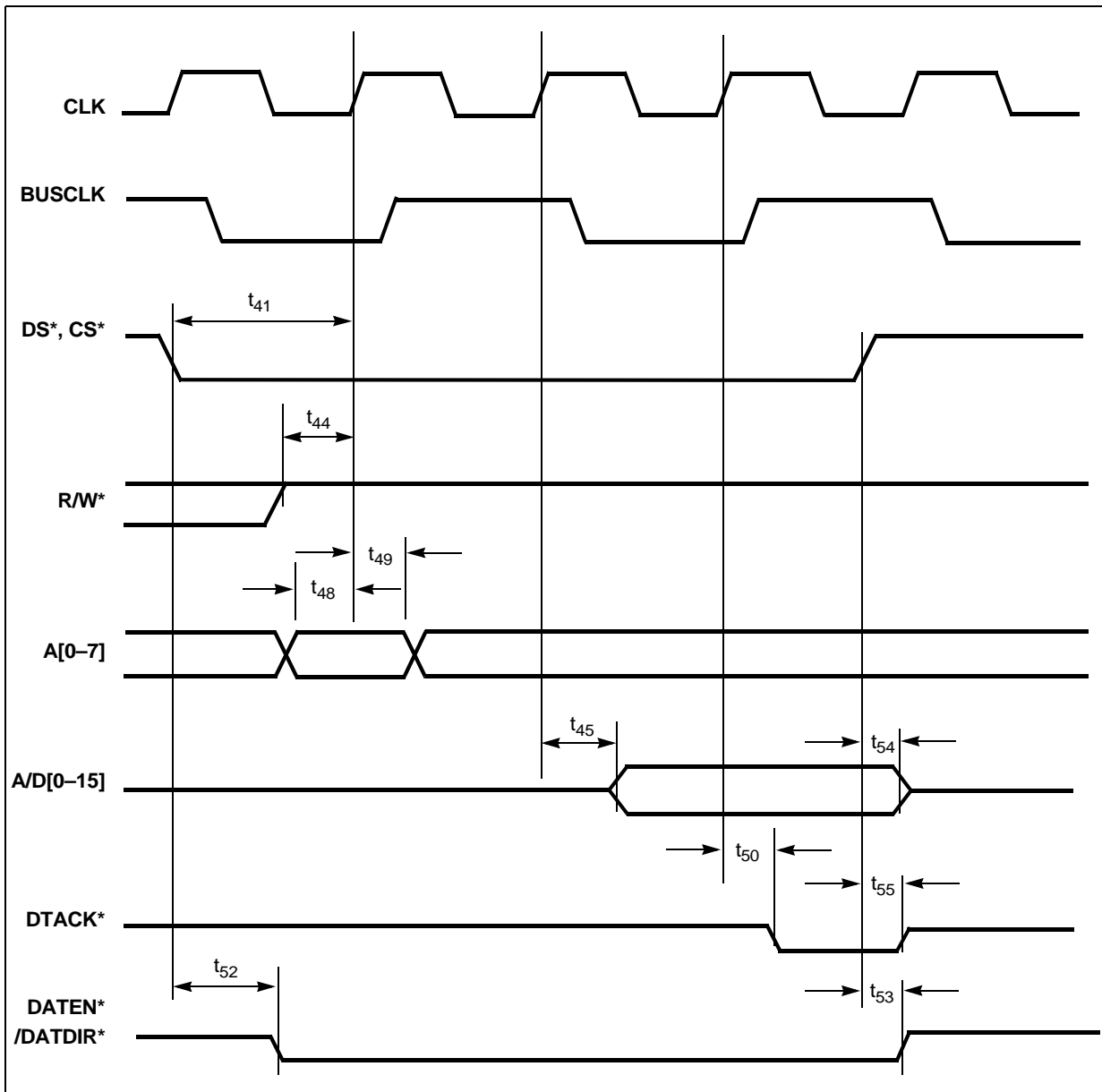



Figure 23. Slave Write Cycle Timing

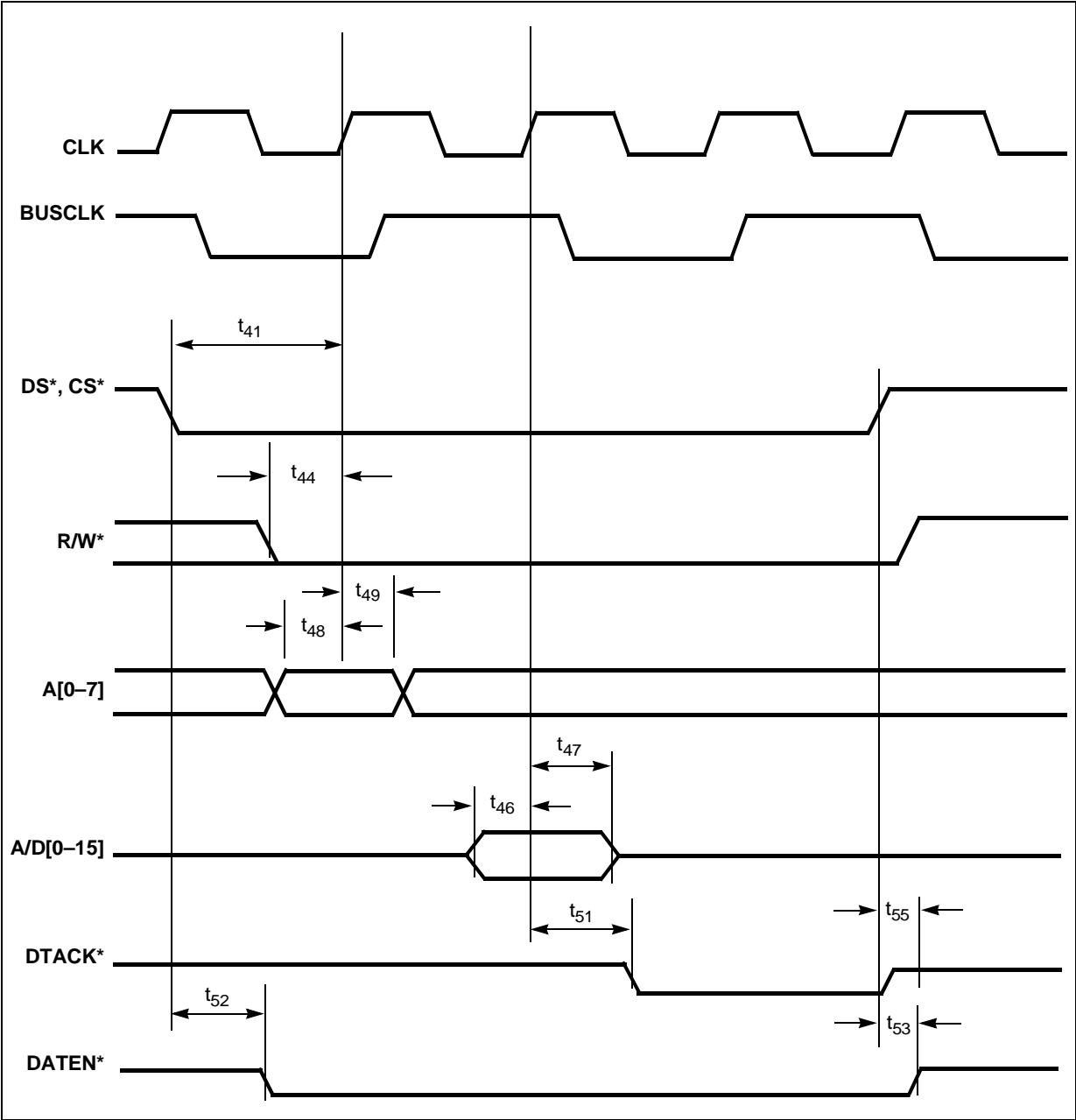

Figure 24. Interrupt Acknowledge Cycle Timing

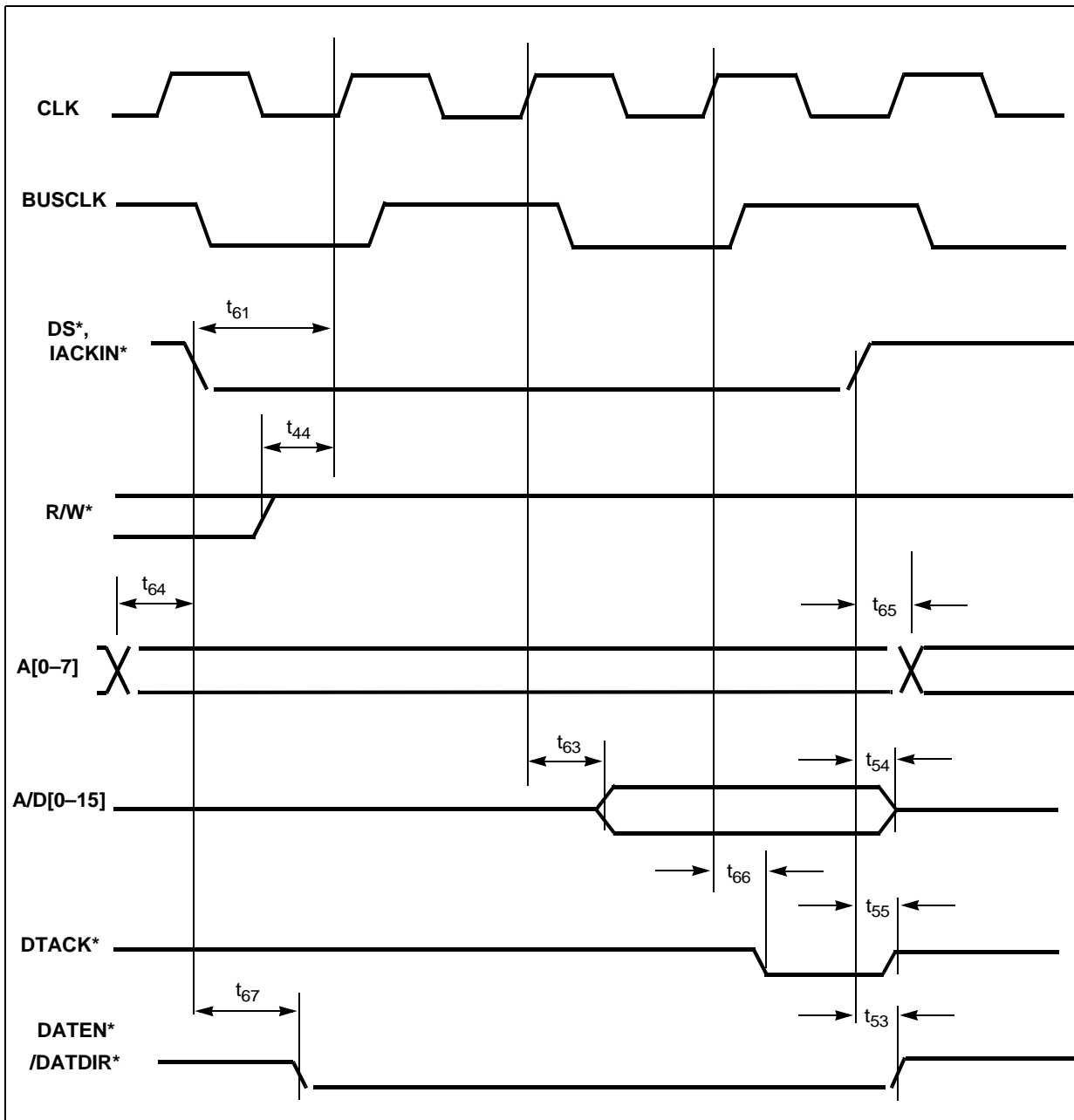

Figure 25. Bus Arbitration Cycle Timing

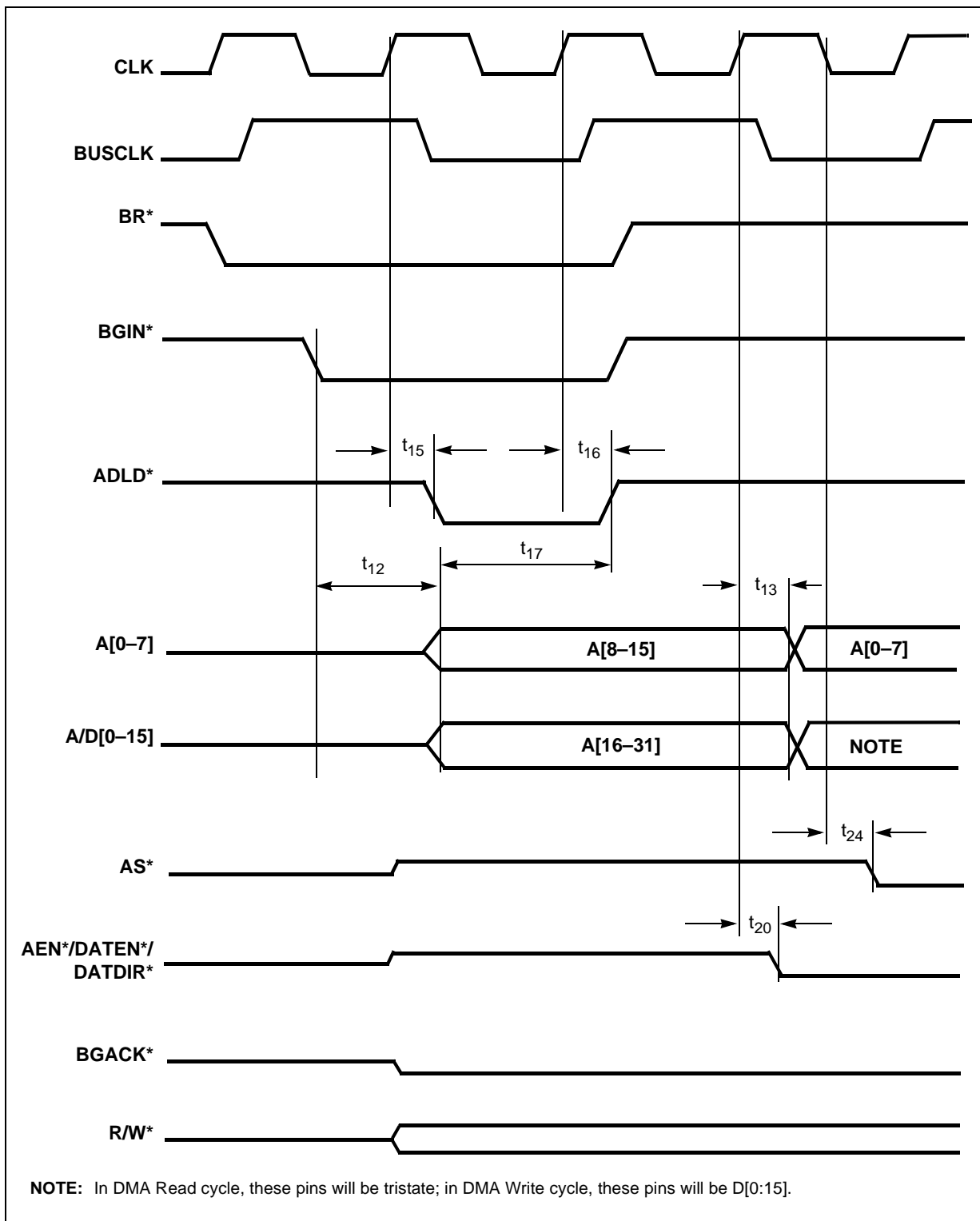

Figure 26. Bus Release Timing

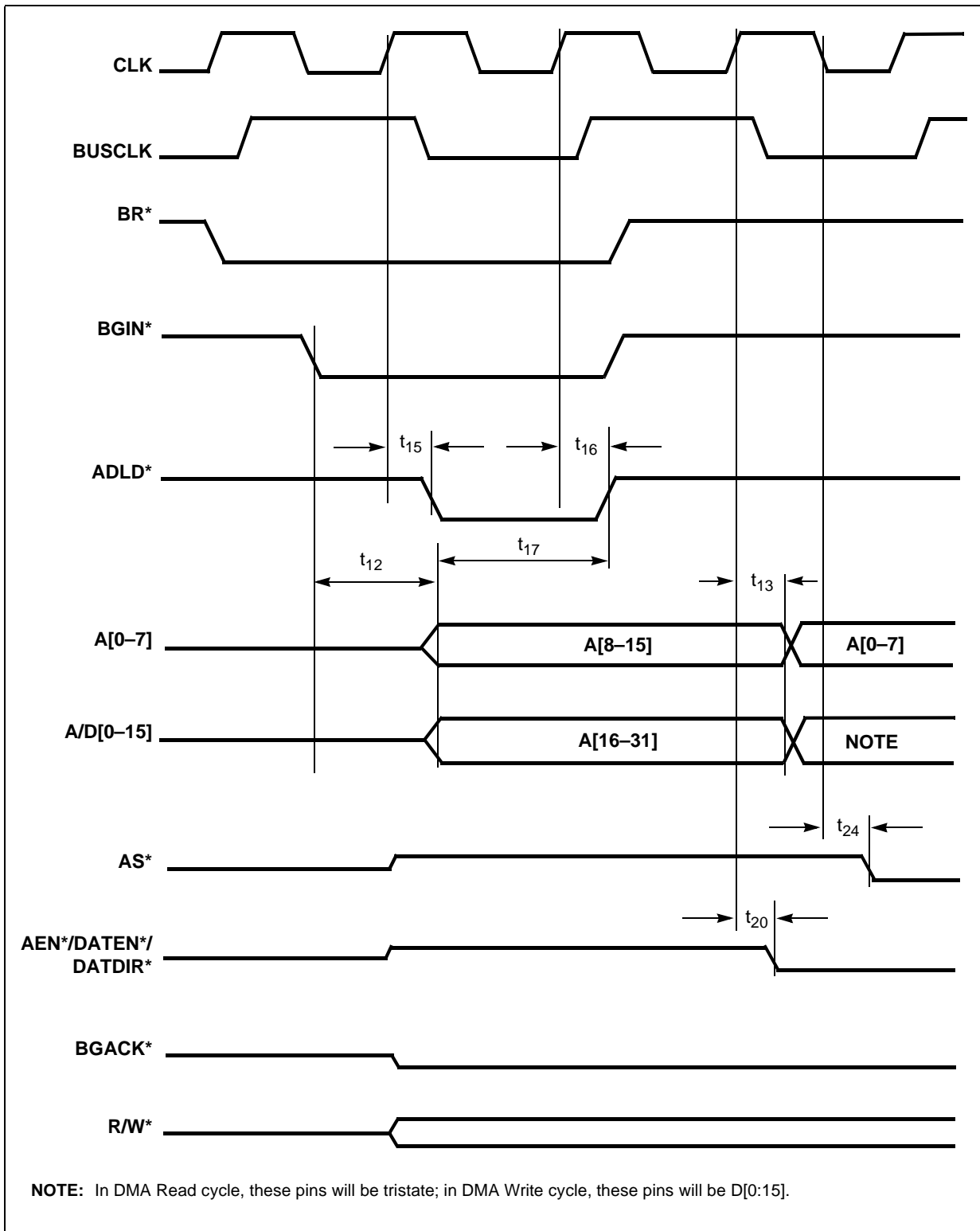



Figure 27. Bus Release Timing

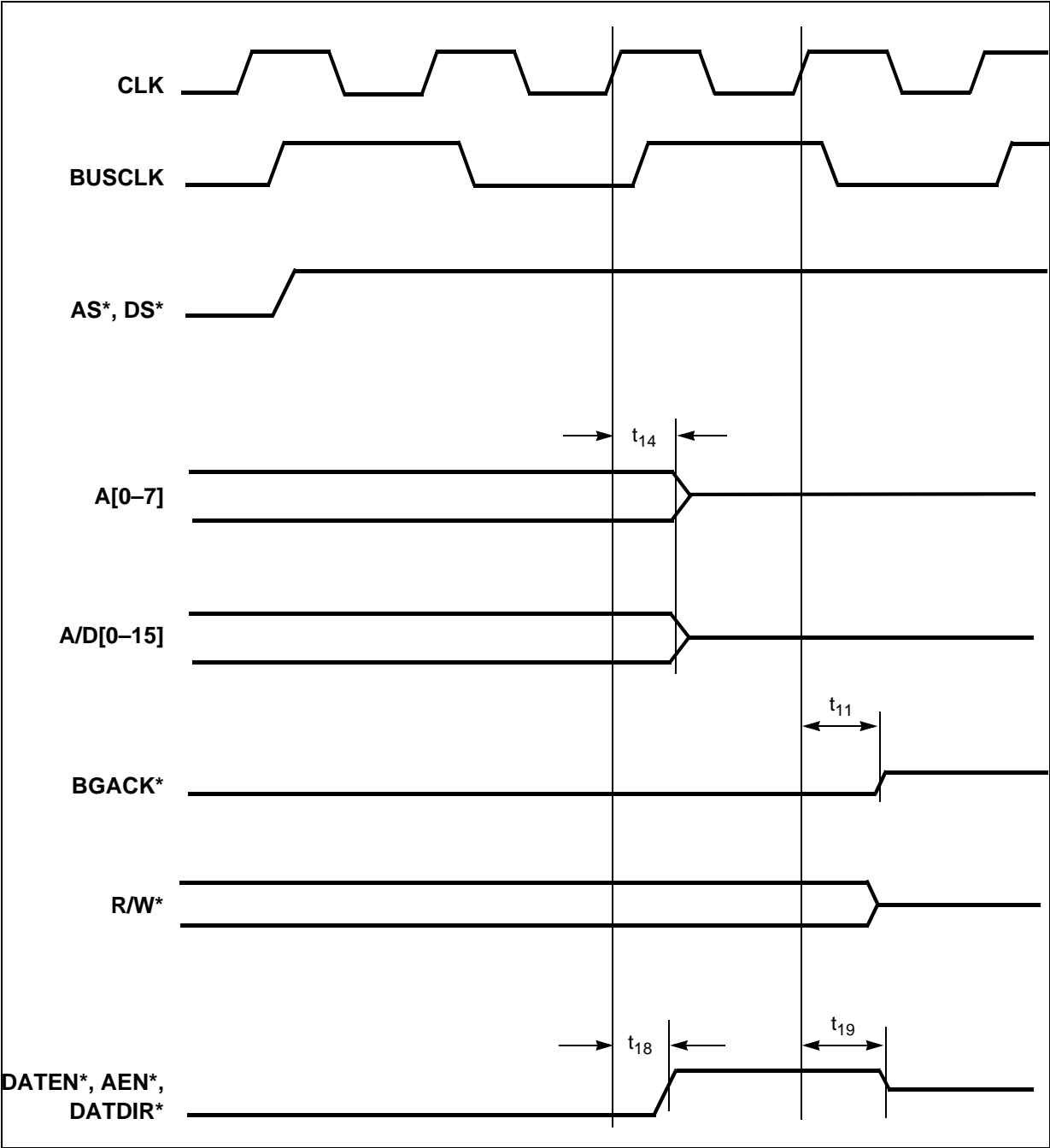

Figure 28. DMA Read Cycle Timing

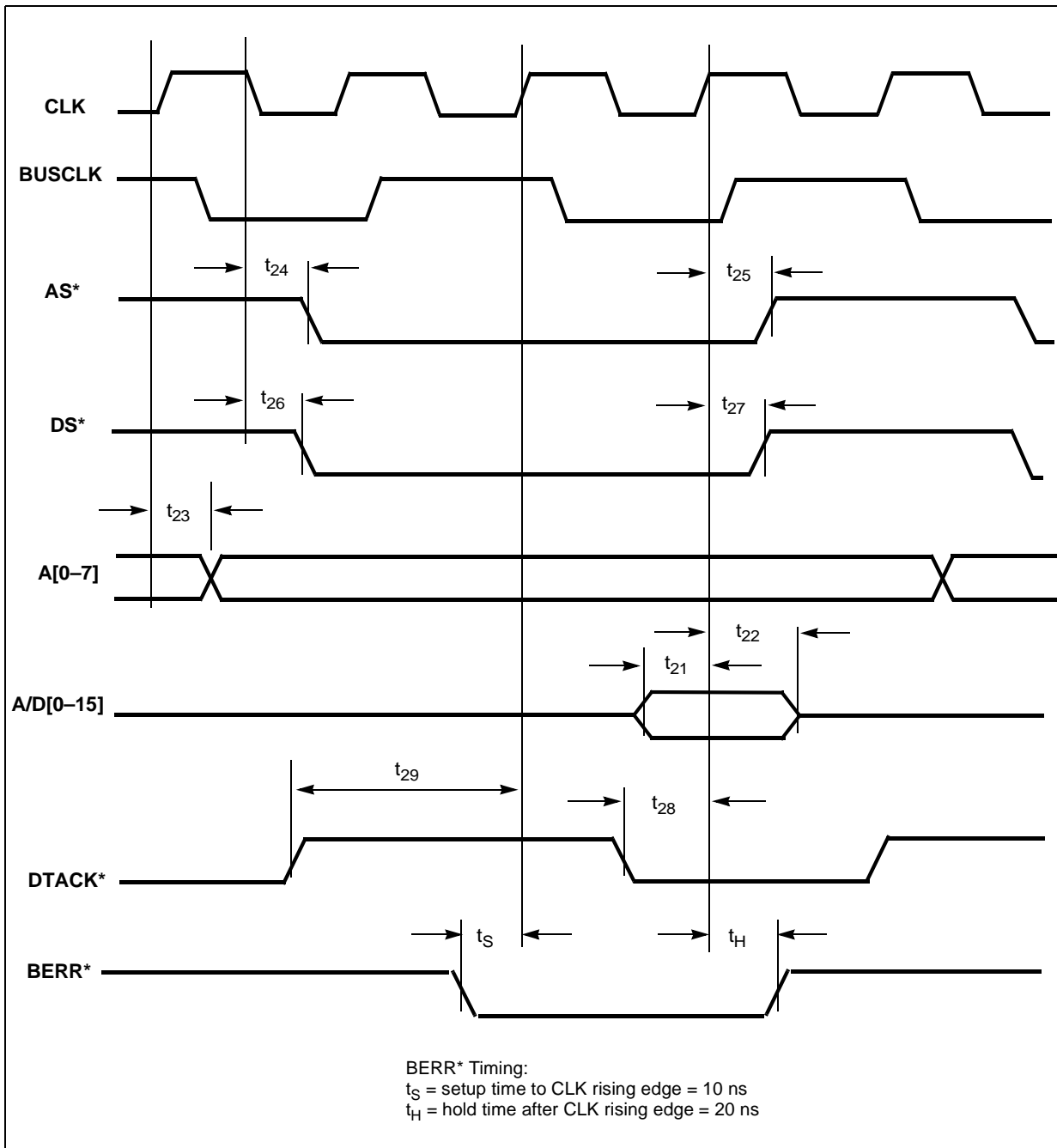
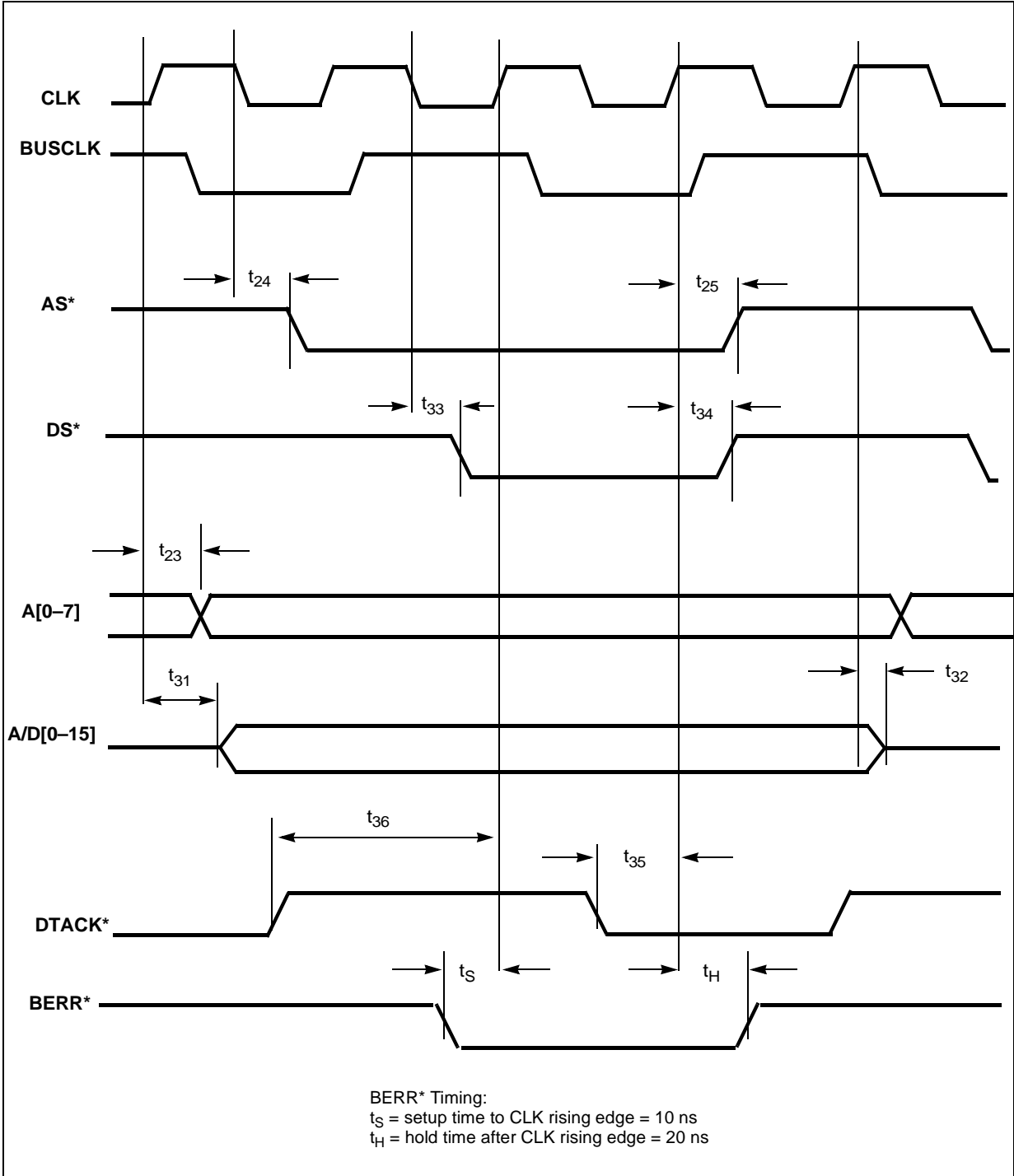
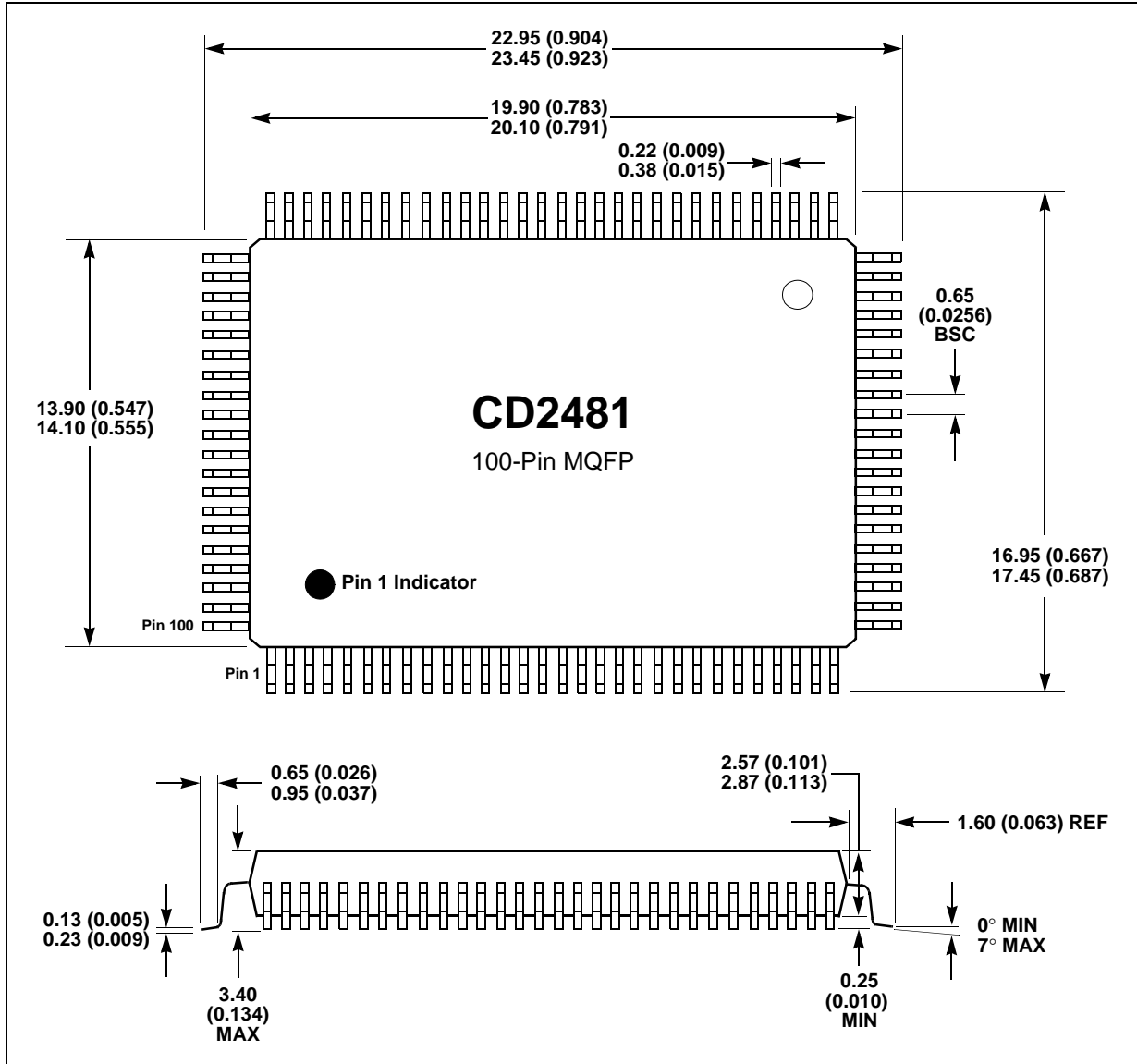

Figure 29. DMA Write Cycle Timing



11.0 Package Specifications



NOTES:

1. Dimensions are in millimeters (inches), and controlling dimension is millimeter.
2. Before beginning any new design with this device, please contact Intel for the latest package information.

12.0 Ordering Information Example

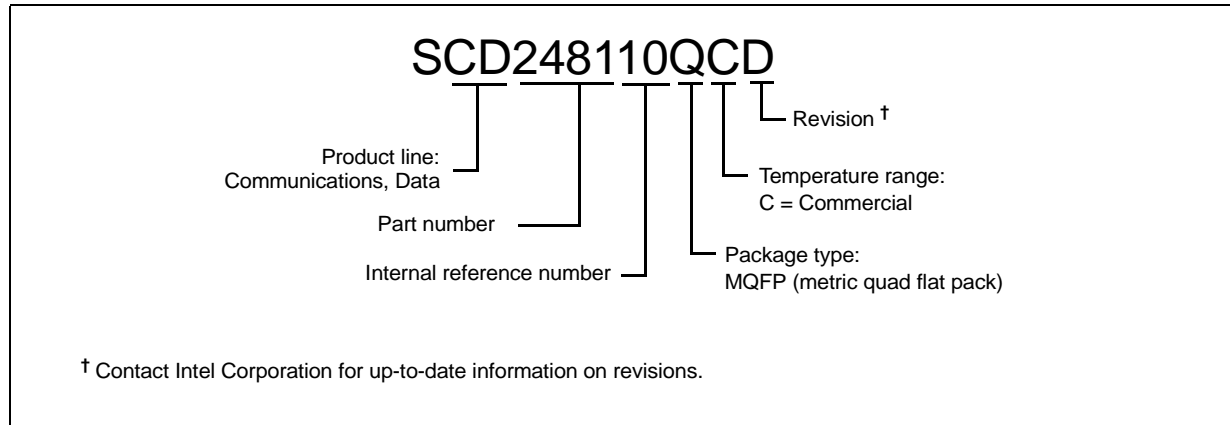

A

- abbreviations 13
- absolute maximum ratings 201, 203
- AC electrical characteristics
 - bus arbitration 202, 205
 - DMA read 202, 205
 - DMA write 202, 205
 - host read/write 202, 205
 - interrupt acknowledge 203, 206
- Addressing mode 114
- Append mode 58
- Async-HDLC/PPP mode 127, 151, 156
- Async-HDLC/PPP/MNP4 mode 169
- Asynchronous DMA mode 59
- Asynchronous mode 26, 118, 125, 155, 167
- Asynchronous/Async-HDLC/PPP mode 118, 120

B

- Bisync 92
- Bisynchronous mode 117, 124, 154
- bit rate generation 60
- BRG operation 60
- buffer allocation 55
- buffers and chaining 48
- bus acquisition cycle 46, 47
- bus arbitration 202, 205
- bus error handling 47
- byte and word transfers 39

C

- character format 77
- CLK 206
- CLK/BUSCLK/RESET* Timing Relationship 206
- contexts and channels 40
- cycles

- bus acquisition 46, 47
- hardware signals and IACK 42
- host read 38
- host read and write 37
- host write 39
- interrupt acknowledge 41

D

- data clock selection 67
- data encoding 60, 66
- DC electrical characteristics 201, 204
- DMA data transfer 46
- DMA operation 45
- DMA read 202, 205
- DMA write 202, 205
- DPLL mode 145
- DPLL operation 60

E

- electrical specifications 201

F

- Fair Share scheme 43
- FCS (frame check sequence) 75
- FCS mode 124
- FCT (flow control transparency) mode 126, 138
- fields, A and C 77
- FIFO and timer operations 44
- format
 - character 77
 - frame 77
- frame check sequence (FCS) 75
- frame format 77
- functional description 37

H

- hardware configurations
 - 32-bit data bus 68
 - DMA connections 68
 - DTE and DCE interface 68
- hardware signals and IACK cycles 42
- HDLC mode 114, 116, 123, 153, 165
- host interface 37
- host read and write cycles 37
- host read/write 202, 205

I

- IACKIN* 43
- IACKOUT* 43
- Idle mode 124
- interrupt acknowledge 203, 206
- interrupts
 - acknowledge cycle 41
 - contexts and channels 40
 - groups and types 41
 - IACK cycles 42
 - keep and pass logic 43
 - multi-CD2481 systems 43
 - registers 40
 - systems with interrupt controllers 43
 - transmit and receive interrupt service requests 42

K

- keep and pass logic 43

L

- Local Loopback mode 147
- logic, keep and pass 43

M

- mapped characters
 - 00-1F 78
 - 20 and above 78
 - 7D and 7E 78
 - in the FCS field 79

- Mark Idling mode 123
- memory map 20
- MNP4 mode 129
- MNP4/SLIP mode 122
- modes
 - Addressing mode 114
 - Append mode 58
 - Async-HDLC/PPP mode 127, 151, 156
 - Async-HDLC/PPP/MNP4 mode 169
 - Asynchronous DMA mode 59
 - Asynchronous mode 26, 118, 125, 155, 167
 - Asynchronous/Async-HDLC/PPP mode 118, 120
 - Bisynchronous mode 117, 124, 154
 - Chain mode 49
 - DPLL mode 145
 - FCS mode 124
 - FCT (flow control transparency) mode 126, 138
 - HDLC mode 114, 116, 123, 153, 165
 - Idle mode 124
 - Local Loopback mode 147
 - Mark Idling mode 123
 - MNP4 mode 129
 - MNP4/SLIP mode 122
 - Parity mode 115
 - PPP 120
 - Protocol mode 113
 - Receive Transfer mode 113
 - Remote Loopback mode 119, 121, 122
 - SLIP mode 128, 170
 - SLIP/MNP4 mode 152, 157
 - Syn/Flag Hunt mode 150
 - Synchronous mode 123
 - Transmit Transfer mode 113
 - XON mode 118, 121
- multi-CD2481 systems 43

O

- operations
 - BRG 60

- DMA 45
- DPLL 60
- FIFO and timer 44
 - receive FIFO 44
 - transmit FIFO 44
- ordering information example 216

P

- package specifications 215
- Parity mode 115
- pin descriptions 16
- pin diagram 15
- pin functions 16
- PPP mode 120
- Programmable Sync 100
- Programmable Sync Mode 122, 135, 136
- programming the PILR registers 42
- Protocol mode 113
- protocol processing 75

R

- read cycle, host 38
- receive buffer interrupts 58
- receive bus errors 59
- receive DMA transfer 53
- receive FIFO operation 44
- receive time-out 59
- Receive Transfer mode 113
- receiver
 - A and B buffers 53
 - fixed operations 80
 - options 80
- register definitions 25
- register descriptions, detailed 112
- register table 20
- registers
 - Bit Rate and Clock Option registers
 - RBPR 22, 29, 145
 - RCOR 22, 29, 145
 - TBPR 22, 29, 146
 - TCOR 22, 29, 147
 - Channel Command and Status registers

- CCR 22, 29, 148
- CSR 22, 30, 153
- MSVR-DTR 22, 31, 158
- MSVR-RTS 22, 31, 158
- STCR 22, 30, 150
- DMA Receive registers
 - ARBADRL 24, 34, 184
 - ARBADRU 24, 34, 184
 - ARBCNT 24, 34, 186
 - ARBSTS 24, 34, 186
 - BRBADRL 24, 34, 185
 - BRBADRU 24, 34, 185
 - BRBCNT 24, 34, 186
 - BRBSTS 24, 34, 187
 - RCBADRL 24, 34, 188
 - RCBADRU 24, 34, 188
- DMA registers
 - BERCNT 24, 34, 182
 - DMABSTS 24, 34, 183
 - DMR 24, 34, 182
- DMA Transmit registers
 - ATBADRL 24, 34, 189
 - ATBADRU 24, 34, 189
 - ATBCNT 24, 35, 191
 - ATBSTS 24, 35, 191, 193, 194, 195
 - BTBADRL 24, 35, 190
 - BTBADRU 24, 35, 190
 - BTBCNT 24, 35, 191
 - BTBSTS 24, 35, 192, 193
 - TCBADRL 24, 35, 196
 - TCBADRU 24, 35, 196
- Global registers
 - CAR 20, 25, 112
 - GFRCR 20, 25, 112
- Interrupt registers
 - IER 22, 31, 160, 161
 - LICR 22, 31, 162
 - LIVR 22, 31, 159
 - STK 22, 31, 162
- Modem Interrupt registers
 - MEOIR 23, 34, 181
 - MIR 23, 33, 179
 - MISR 23, 33, 180

- MPILR 23, 33, 179
 - Option registers
 - CMR 21, 25, 113
 - COR1 21, 25, 114
 - COR2 21, 26, 116
 - COR3 21, 26, 123, 124
 - COR4 21, 27, 130
 - COR5 21, 27, 131
 - COR6 21, 27, 132, 134
 - COR7 21, 28, 135
 - CPSR 21, 28, 141
 - LNXT 21, 28, 139
 - RFAR1 21, 28, 139
 - RFAR2 21, 28, 140
 - RFAR3 21, 28, 140
 - RFAR4 21, 28, 140
 - RXACCM0 21, 29, 143
 - RXACCM1 21, 29, 144
 - RXACCM2 21, 29, 144
 - RXACCM3 21, 29, 144
 - SCHR1 21, 28, 136
 - SCHR2 21, 28, 137
 - SCHR3 21, 28, 138
 - SCHR4 21, 28, 138
 - SCRh 21, 28, 139
 - SCRI 21, 28, 138
 - TSPMAP1 21, 28, 141
 - TSPMAP2 21, 29, 141
 - TSPMAP3 21, 29, 142
 - TXACCM0 21, 29, 142
 - TXACCM1 21, 29, 142
 - TXACCM2 21, 29, 143
 - TXACCM3 21, 29, 143
 - Receive Interrupt registers
 - RDR 23, 32, 172
 - REOIR 23, 32, 173
 - RFOC 23, 32, 172
 - RIR 23, 31, 164
 - RISR 23, 32
 - RISRh 23, 32, 171
 - RISRl 23, 32
 - RPILR 23, 31, 163
 - Timer registers
 - GT1 25, 36, 198
 - GT1h 25, 36, 199
 - GT1l 25, 36, 198
 - GT2 25, 36, 199
 - RTPR 25, 35, 197
 - RTPRh 25, 36, 198
 - RTPRl 25, 35, 197
 - TPR 25, 35, 197
 - TTR 25, 36, 200
 - Transmit Interrupt registers
 - TDR 23, 33, 177
 - TEOIR 23, 33, 178
 - TFTC 23, 33, 177
 - TIR 23, 33, 175
 - TISR 23, 33, 176
 - TPILR 23, 33, 175
 - Remote Loopback mode 119, 121, 122
- ## S
- Short Frame Processing 92
 - SLIP mode 128, 170
 - SLIP/MNP4 mode 152, 157
 - Syn/Flag Hunt mode 150
 - Synchronous mode 123
 - synchronous transmitter examples 50
- ## T
- timers
 - asynchronous protocols 45
 - synchronous protocols 45
 - transmit 45
 - timing
 - bus arbitration cycle 210
 - bus release 211, 212
 - DMA read cycle 213
 - DMA write cycle 214
 - interrupt acknowledge cycle 209
 - slave read cycle 207
 - slave write cycle 208
 - transfers, byte and word 39
 - transmit and receive interrupt service requests 42



- transmit bus errors 58
- transmit data 66
- transmit DMA buffers
 - chained buffers 55
 - DMA selection 57
 - interrupts 55
- transmit DMA transfer
 - Append mode 49
 - Chain mode 49
- transmit FIFO operation 44
- Transmit Transfer mode 113
- transmitter
 - fixed operations 79
 - framing error 80
 - options 79

- transmission of abort 80
- transmitter A and B buffers 50
- transparency 78
- Transparency support 94

V

- valid frame, definition 79

W

- write cycle, host 39

X

- XON mode 118, 121

Looking for pricing, stock, or lifecycle information?

Click below to explore more details on WIN SOURCE:

 [View SCD248110QCD on WIN SOURCE](#)

 [Intel Information](#)

Optimize Your Supply Chain with WIN SOURCE Solutions

-  Global Sourcing Solution
-  Obsolete Management
-  Cost Control Management
-  Shortage Management
-  Alternative Solution
-  Excess Inventory Management