



**THE DATASHEET OF
SE2577L-R**





DATA SHEET

SE2577L: Dual-Band 802.11n Wireless LAN Front-End Module

Applications

- 802.11n, MIMO solutions
- IEEE 802.11g OFDM WLAN
- IEEE 802.11a OFDM WLAN
- Access points, PCMCIA, PC cards

Features

- Passive front end, including two SPDT switches and diplexer
- Integrated 2 GHz low pass filter
- Able to accept 20 dBm of linear input power in both bands with no EVM contribution
- Lead free, Halogen Free and RoHS compliant
- Thin lead-free plated QFN package (20-pin, 3 x 3 x 0.9 mm, (MSL1, 260 °C per JEDEC J-STD-020)



Skyworks Green™ products are compliant with all applicable legislation and are halogen-free. For additional information, refer to *Skyworks Definition of Green™*, document number SQ04-0074.

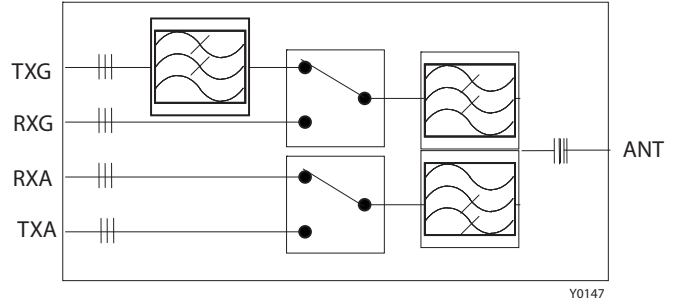

Figure 1. SE2577L Block Diagram (RF Ports are DC Blocked)

Description

The SE2577L is a dual-band passive 802.11n WLAN RF front-end module providing the functionality of spurious filters, switches and diplexer. All RF ports are matched to 50 Ω to simplify PCB layout and the interface to the transceiver RFIC.

The Front End is packaged in a very compact RoHS compliant, Halogen Free, and Lead Free 3mm x 3mm x 0.9mm QFN style package.

A functional block diagram of the SE2577L is provided in Figure 1. Figure 2 shows the pinout for the SE2577L. Table 1 lists the signal pin assignments and functional pin descriptions.

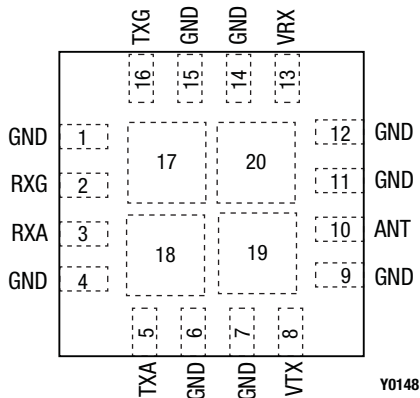

Figure 2. SE2577L Pinout – 20-Pin QFN (Top View)

Table 1. SE2577L Signal Descriptions

Pin	Name	Description	Pin	Name	Description
1	GND	Ground	11	GND	Ground
2	RXG	2 GHz Receive Output	12	GND	Ground
3	RXA	5 GHz Receive Output	13	VRX	Receive Switch Control
4	GND	Ground	14	GND	Ground
5	TXA	5 GHz Transmit Input	15	GND	Ground
6	GND	Ground	16	TXG	2 GHz Transmit Input
7	GND	Ground	17	GND	Ground
8	VTX	Transmit Switch Control	18	GND	Ground
9	GND	Ground	19	GND	Ground
10	ANT	Antenna	20	GND	Ground

Electrical and Mechanical Specifications

The absolute maximum ratings of the SE2577L are provided in Table 2. The recommended operating conditions are specified in Table 3 and electrical specifications are provided in Tables 4 through 7.

Table 2. SE2577L Absolute Maximum Ratings (Note 1)

Parameter	Symbol	Minimum	Maximum	Units
High-level logic control voltage	V _{CTL_ON}		3.6	V
CW power on port 2TX, 5TX, ANT terminated into 50 Ω match	T _{XRF}		+33	dBm
Operating temperature	T _A	-40	+85	°C
Storage temperature	T _{S2TX}	-40	+150	°C
Electrostatic discharge:	ESD			
All pins			200	V
Antenna pin with external 4 pF blocking capacitor			1500	V

Note 1: Exposure to maximum rating conditions for extended periods may reduce device reliability. There is no damage to device with only one parameter set at the limit and all other parameters set at or below their nominal value. Exceeding any of the limits listed here may result in permanent damage to the device.

CAUTION: Although this device is designed to be as robust as possible, electrostatic discharge (ESD) can damage this device. This device must be protected at all times from ESD. Static charges may easily produce potentials of several kilovolts on the human body or equipment, which can discharge without detection. Industry-standard ESD precautions should be used at all times.

Table 3. SE2577L Recommended Operating Conditions

Parameter	Symbol	Minimum	Typical	Maximum	Units
Ambient temperature	T _A	-40	+25	+85	°C

Table 4. SE2577L Electrical Specifications: RF Switch Characteristics (Note 1)

(TA = +25 °C, as Measured on the Evaluation Board [De-Embedded to the Device], All Unused Ports are Terminated with 50 Ω, Unless Otherwise Noted)

Parameter	Symbol	Test Condition	Min	Typical	Max	Units
Control voltage: ON state	VCTL_ON		3.0	3.3	3.6	V
OFF state	VCTL_OFF		0		0.3	V
Switch control bias circuit: RF applied	ICTL_ON	On pin (VTX, VRX) driven high		0.5	1.5	mA
No RF		On pin (VTX, VRX) driven high		0.5	1.5	mA
10% to 90 % rise fall time	Switch speed			250		ns
Control input capacitance	CCTL				10	pF

Note 1: Performance is guaranteed only under the conditions listed in this table.

Table 5. SE2577L Electrical Specifications: RF Switch Logic and Function Characteristics

RF Switch Logic		RF Switch Function	
VTX	VRX	TXG, TXA <-> ANT	RXG, RXA <-> ANT
VCTL_OFF	VCTL_OFF	OFF	OFF
VCTL_ON	VCTL_OFF	ON	OFF
VCTL_OFF	VCTL_ON	OFF	ON
VCTL_ON	VCTL_ON	Not a supported state	

Table 6. SE2577L Electrical Specifications: 2.4 GHz AC Electrical Characteristics (1 of 2)

(TA = +25 °C, as Measured on the Evaluation Board [De-Embedded to Device], All Unused Ports Terminated at 50 Ω, Unless Otherwise Noted)

Parameter	Symbol	Condition	Min	Typ	Max	Unit
Frequency	f		2400		2485	MHz
Reference input impedance	Ω _L	All RF ports		50		Ω
RF input power	P _{IN}	DSSS OFDM		+23 +22		dBm
Input return loss	S ₁₁	RxG ↔ ANT; TxG ↔ ANT	15			dB
Transmit insertion loss	S ₂₁ TX	TxG ↔ ANT: Excluding external filter components		1.5	1.8	dB
		Includes losses from external filter components		1.8	2.1	dB
Receive insertion loss	S ₂₁ RX	RxG ↔ ANT		1.1	1.4	dB
Output return loss	S ₂₂	RxG ↔ ANT; TxG ↔ ANT	15			dB
0.1dB compression	P0.1dB		+29	+31		dBm
3 rd order intercept	IIP3		+50			dBm
2 nd harmonics rejection	2fo	TxG ↔ ANT: With external components on EK1 PCB	50	55		dB
		Without external components	35	40		dB
3 rd harmonics rejection	3fo	TxG ↔ ANT: With external components on EK1 PCB	50	55		dB
		Without external components	25	28		dB

Table 6. SE2577L Electrical Specifications: 2.4 GHz AC Electrical Characteristics (2 of 2)
 (TA = +25 °C, as Measured on the Evaluation Board [De-Embedded to Device], All Unused Ports Terminated at 50 Ω, Unless Otherwise Noted)

Parameter	Symbol	Condition	Min	Typ	Max	Unit
Output 2 nd harmonic power generated at P _{IN} = +22 dBm, CW	PSD2	TXG ↔ ANT, no source contribution to harmonics		-50		dBm
Output 3 rd harmonic power generated at P _{IN} = +22 dBm, CW	PSD3	TXG ↔ ANT, no source contribution to harmonics		-50		dBm
5 to 2 GHz isolation	Isol	TXG ↔ ANT, Measure @RXA	40	50		dB
		TXG ↔ ANT, Measure @TXA	20	40		dB
RXG to TXG		TXG ↔ ANT, Measure @RXG	20	30		dB
RXG to ANT		TXG ↔ ANT, Measure @RXG; TXG is not terminated	20	27	33	dB
RF to non-RF		Any RF pin to VRX, VTX, with 1.6pF cap on control lines	40			dB

Table 7. Electrical Specifications: 5 GHz AC Electrical Characteristics (TA = 25 °C, as Measured on the Evaluation Board [De-Embedded to Device], All Unused Ports Terminated with 50 Ω, Unless Otherwise Noted)

Parameter	Symbol	Test Condition	Min	Typ	Max	Unit
Frequency	f		4900		5875	MHz
Reference input impedance	Ω _L	All RF ports		50		Ω
RF input power	P _{IN}	OFDM		+21		dBm
Input return loss	S ₁₁	RxA ↔ ANT; TxA ↔ ANT	15			dB
Transmit insertion loss	S _{21 TX}	TxA ↔ ANT			2.1	dB
Receive insertion loss	S _{21 RX}	RxA ↔ ANT			2.1	dB
Output return loss	S ₂₂	RxA ↔ ANT; TxA ↔ ANT	15			dB
0.1dB compression	P _{0.1dB}		+29	+31		dBm
3 rd order intercept	IIP3		+50			dBm
2 nd harmonics rejection	2f _o	TxA ↔ ANT		20		dB
3 rd harmonics rejection	3f _o	TxA ↔ ANT		15		dB
Output 2 nd harmonic power generated at P _{IN} = +22 dBm, OFDM	PSD2	TxA ↔ ANT		-50		dBm/MHz
Output 3 rd harmonic power generated at P _{IN} = +22 dBm, OFDM	PSD3	TxA ↔ ANT		-50		dBm/MHz
Isolation: 2 to 5 GHz	Isol	TxA ↔ ANT, Measure @ RXG	40			dB
		TxA ↔ ANT, Measure @ TXG	20			dB
RXA to TXA	Isol	TxA ↔ ANT, Measure @ RXA	20			dB
RXG to ANT	Isol	TxA ↔ ANT, Measure @ RXA; TXA is not terminated	20		33	dB
RF to non-RF	Isol	Any RF pin to VRX, VTX (with 1.6 pF cap on control lines)	40			dB

Evaluation Board Description

The SE2577L Evaluation Board is used to test the performance of the SE2577L FEM. A suggested application schematic diagram is shown in Figure 3. An Evaluation Board assembly diagram is shown in Figure 4. Component values for the SE2577L Evaluation Board are listed in the Bill of Materials (BOM) in Table 8.

Circuit Design Considerations

The following design considerations are general in nature and must be followed regardless of final use or configuration:

- Paths to ground should be made as short as possible.
- The ground pad of the SE2577L has special electrical and thermal grounding requirements. This pad is the main thermal conduit for heat dissipation. Since the circuit board acts as the heat sink, it must shunt as much heat as possible from the device.

Therefore, design the connection to the ground pad to dissipate the maximum wattage produced by the circuit board. Multiple vias to the grounding layer are required.

NOTE: A poor connection between the ground pad and ground increases junction temperature (T_J), which reduces the life of the device.

Evaluation Board Setup Procedure

1. Connect system ground to pin 2 of connectors J6 and J20.
2. Test the Antenna to Receive Port by applying the switch settings of RX – ANT as described in Table 5.
3. The RX to ANT performance can be monitored by applying an RF signal to J4 (ANT), and measuring the response from either J1 (5 GHz) or J5 (2 GHz) RX outputs.
4. Test the Transmit to Antenna Port by applying the switch settings of TX – ANT as described in Table 5.
5. Amplifier performance at 2.5 GHz can be monitored by applying an RF signal to connector J2 and monitoring the output power on the antenna port connector J4 (ANT).
6. Amplifier performance at 5 GHz can be monitored by applying an RF signal to connector J3 and monitoring the output power on the antenna port connector J4 (ANT).

Caution: Care should be taken not to overdrive the amplifier by applying too much RF on the input to the device. A suitable starting input power for the device is +20 dBm.

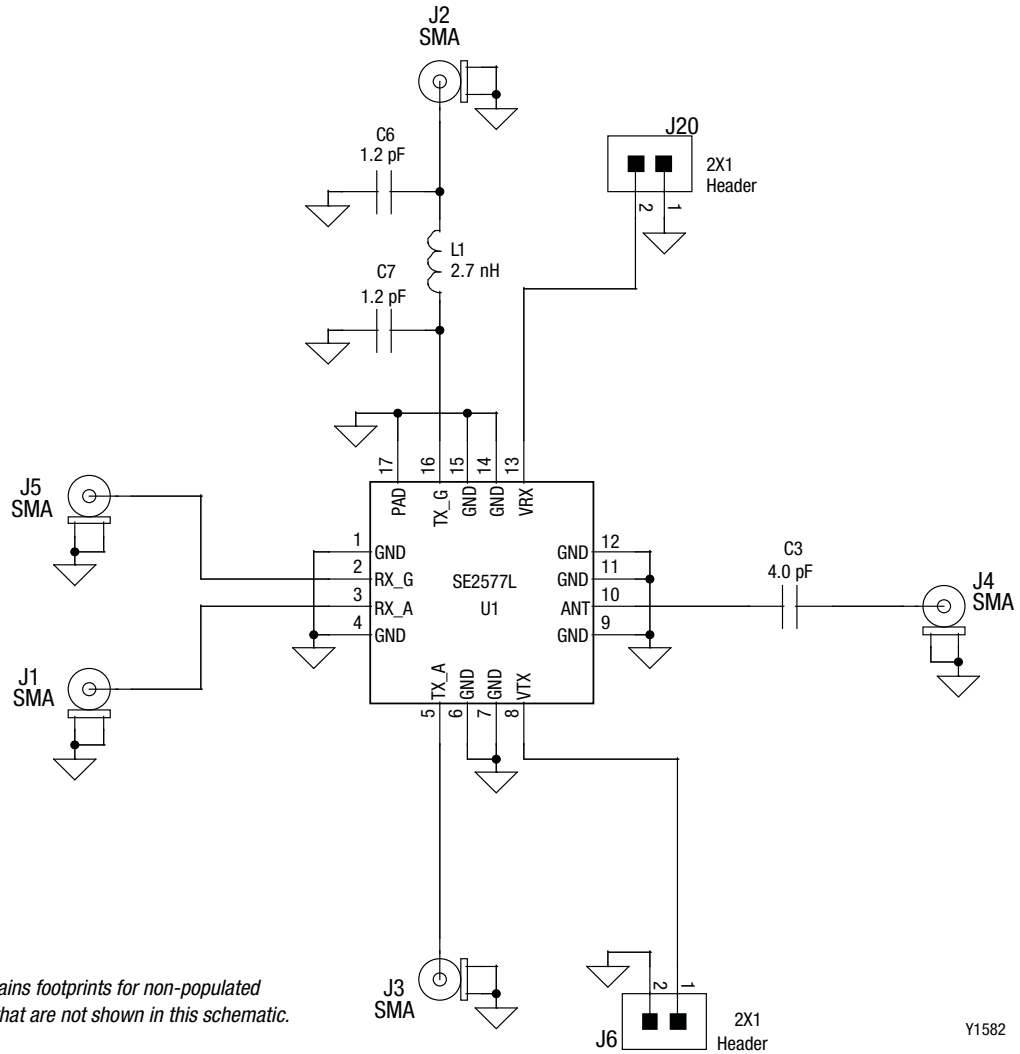

Y1582

Figure 3. SE2577L Suggested Application Schematic

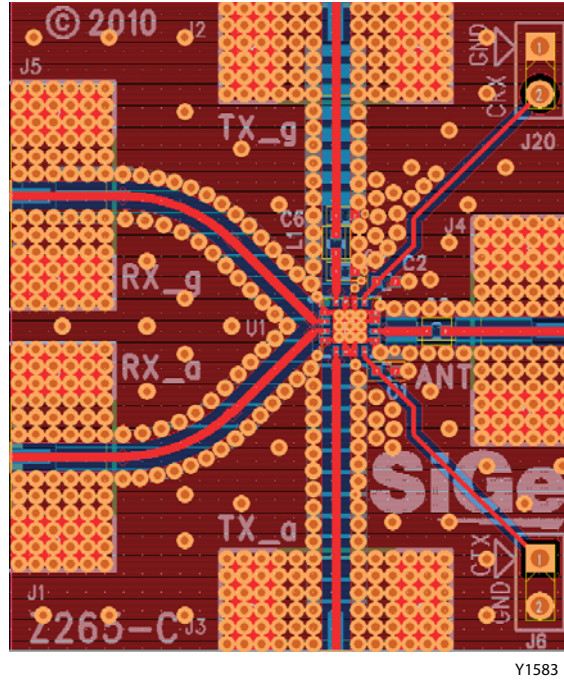

Figure 4. SE2577L Evaluation Board Assembly Diagram

Table 8. SE2577L Evaluation Board Bill of Materials

Component	Value	Manufacturer	Mfr Part Number	Package	Description
C3	4.0 pF	Murata	GRM1555C1H4ROCZ01	0402	Multilayer ceramic
C6, C7	1.2 pF	Murata	GRM1555C1H1R2CZ01	0402	Thick film chip resistor
J1, J2, J3, J4, J5	SMA	Johnson Components	142-0701-851	End launch	SMA end launch straight jack receptacle – tab contact
J6, J20	2X1	Molex	22-28-4023	100 mil	100 mil header
L1	2.7 nH	Murata	LQG15HN2N7S02D	0402	Monolithic Inductor (Air-core)
U1		Skyworks	SE2577L	SE2577L	Dual band switch diplex FEM

Package Dimensions

The recommended land and solder patterns for the SE2577L are provided in Figure 5. Typical case markings are shown in Figure 6. Package dimensions for the are shown in Figure 7, and tape and reel dimensions are provided in Figure 8.

when the part is subjected to high temperature during solder assembly.

The SE2577L is rated to Moisture Sensitivity Level 1 (MSL1) at 260 °C. It can be used for lead or lead-free soldering. For additional information, refer to the Skyworks Application Note, *Solder Reflow Information*, document number 200164.

Package and Handling Information

Instructions on the shipping container label regarding exposure to moisture after the container seal is broken must be followed. Otherwise, problems related to moisture absorption may occur

Care must be taken when attaching this product, whether it is done manually or in a production solder reflow environment. Production quantities of this product are shipped in a standard tape and reel format.

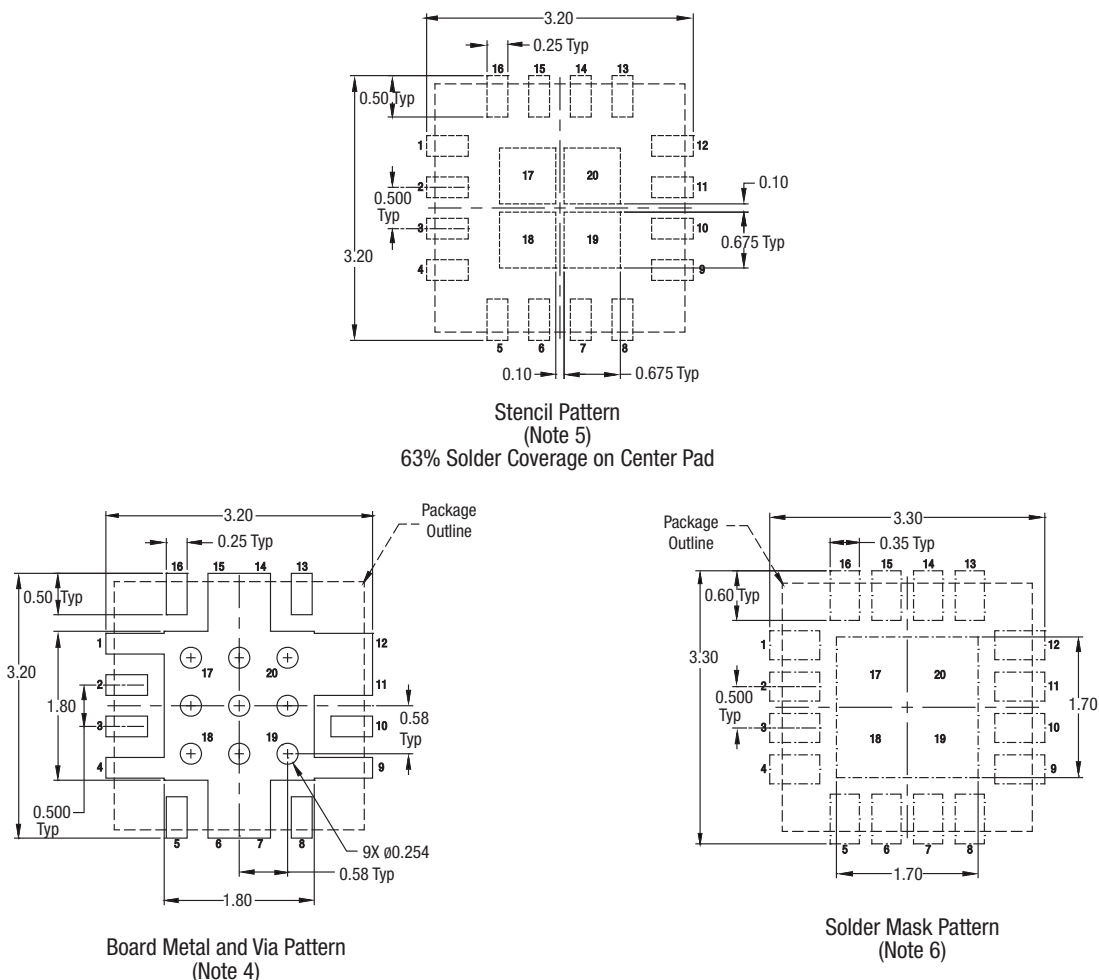

Notes:

1. All dimensions are in millimeters.
2. Dimensions and tolerances per ASME Y14.5M-1994.
3. Unless specified, dimensions are symmetrical about center lines.
4. Via hole recommendations: 30-35 µm Cu via wall plating; via holes should be tented with solder mask on the back side and filled with solder.
5. Stencil recommendations: 0.125 mm stencil thickness, laser cut apertures, trapezoidal walls and rounded corners offer better paste release.
6. Solder mask recommendations: Contact board fabricator for recommended solder mask offset and tolerance.

Y0152

Figure 5. SE2577L Recommended Land and Solder Patterns (Top View)

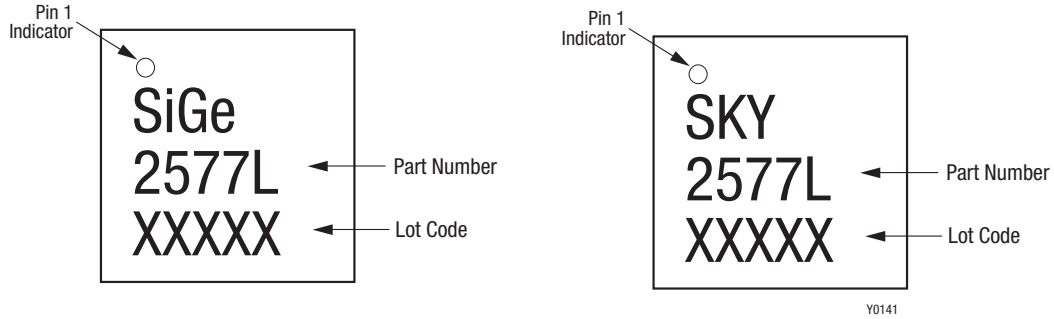
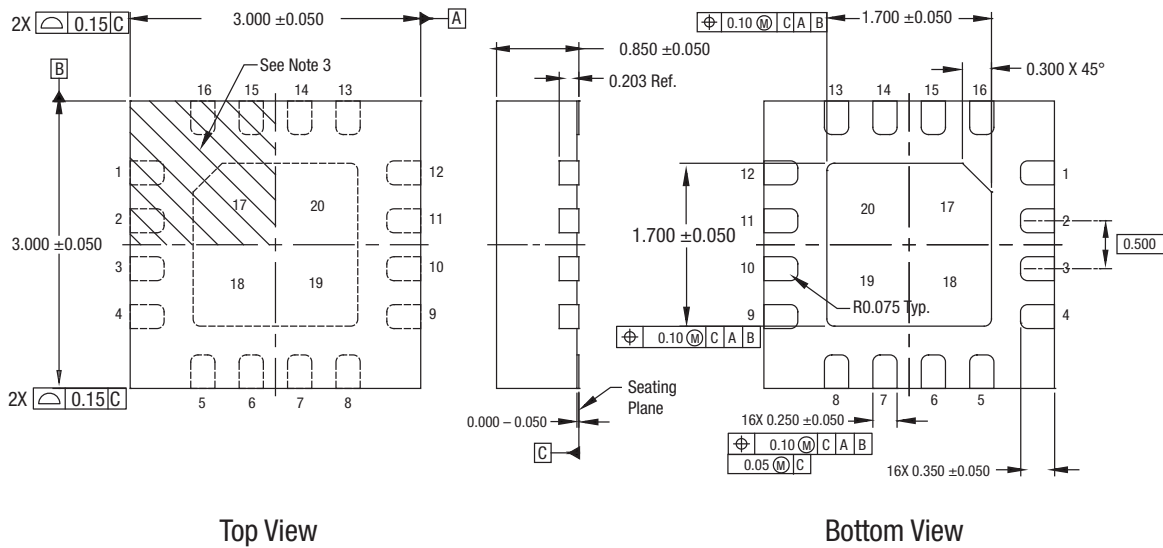

Figure 6. Typical Case Markings (Top View)



- NOTES:
- All measurements are in millimeters.
 - Dimensioning and tolerancing according to ASME Y14.5M-1994. Unless otherwise specified the following values apply:
 Decimal Tolerance: Angular Tolerance:
 X.X (1 place) ± 0.1 mm ± 1°
 X.XX (2 places) ± 0.05 mm
 X.XXX (3 places) ± 0.025 mm
 - Terminal #1 identification mark located within marked area.
 - Coplanarity applies to the exposed heat sink ground pad as well as the terminals.
 - Unless specified, dimensions are symmetrical about center lines.

Y0150

Figure 7. SE2577L Package Dimensions

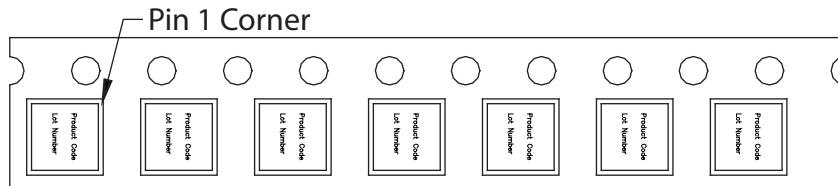

Figure 8. SE2577L Tape and Reel Dimensions

Ordering Information

Model Name	Manufacturing Part Number	Evaluation Board Part Number
SE2577L-S SE2577L-R		SE2577L-EK1

Copyright © 2013-2014 Skyworks Solutions, Inc. All Rights Reserved.

Information in this document is provided in connection with Skyworks Solutions, Inc. (“Skyworks”) products or services. These materials, including the information contained herein, are provided by Skyworks as a service to its customers and may be used for informational purposes only by the customer. Skyworks assumes no responsibility for errors or omissions in these materials or the information contained herein. Skyworks may change its documentation, products, services, specifications or product descriptions at any time, without notice. Skyworks makes no commitment to update the materials or information and shall have no responsibility whatsoever for conflicts, incompatibilities, or other difficulties arising from any future changes.

No license, whether express, implied, by estoppel or otherwise, is granted to any intellectual property rights by this document. Skyworks assumes no liability for any materials, products or information provided hereunder, including the sale, distribution, reproduction or use of Skyworks products, information or materials, except as may be provided in Skyworks Terms and Conditions of Sale.

THE MATERIALS, PRODUCTS AND INFORMATION ARE PROVIDED “AS IS” WITHOUT WARRANTY OF ANY KIND, WHETHER EXPRESS, IMPLIED, STATUTORY, OR OTHERWISE, INCLUDING FITNESS FOR A PARTICULAR PURPOSE OR USE, MERCHANTABILITY, PERFORMANCE, QUALITY OR NON-INFRINGEMENT OF ANY INTELLECTUAL PROPERTY RIGHT; ALL SUCH WARRANTIES ARE HEREBY EXPRESSLY DISCLAIMED. SKYWORKS DOES NOT WARRANT THE ACCURACY OR COMPLETENESS OF THE INFORMATION, TEXT, GRAPHICS OR OTHER ITEMS CONTAINED WITHIN THESE MATERIALS. SKYWORKS SHALL NOT BE LIABLE FOR ANY DAMAGES, INCLUDING BUT NOT LIMITED TO ANY SPECIAL, INDIRECT, INCIDENTAL, STATUTORY, OR CONSEQUENTIAL DAMAGES, INCLUDING WITHOUT LIMITATION, LOST REVENUES OR LOST PROFITS THAT MAY RESULT FROM THE USE OF THE MATERIALS OR INFORMATION, WHETHER OR NOT THE RECIPIENT OF MATERIALS HAS BEEN ADVISED OF THE POSSIBILITY OF SUCH DAMAGE.

Skyworks products are not intended for use in medical, lifesaving or life-sustaining applications, or other equipment in which the failure of the Skyworks products could lead to personal injury, death, physical or environmental damage. Skyworks customers using or selling Skyworks products for use in such applications do so at their own risk and agree to fully indemnify Skyworks for any damages resulting from such improper use or sale.

Customers are responsible for their products and applications using Skyworks products, which may deviate from published specifications as a result of design defects, errors, or operation of products outside of published parameters or design specifications. Customers should include design and operating safeguards to minimize these and other risks. Skyworks assumes no liability for applications assistance, customer product design, or damage to any equipment resulting from the use of Skyworks products outside of stated published specifications or parameters.

Skyworks and the Skyworks symbol are trademarks or registered trademarks of Skyworks Solutions, Inc., in the United States and other countries. Third-party brands and names are for identification purposes only, and are the property of their respective owners. Additional information, including relevant terms and conditions, posted at www.skyworksinc.com, are incorporated by reference.

Looking for pricing, stock, or lifecycle information?

Click below to explore more details on WIN SOURCE:

- ⊖ [View SE2577L-R on WIN SOURCE](#)
- ⊖ [Skyworks Solutions Inc. Information](#)

Optimize Your Supply Chain with WIN SOURCE Solutions

- ✓ Global Sourcing Solution
- ✓ Obsolete Management
- ✓ Cost Control Management
- ✓ Shortage Management
- ✓ Alternative Solution
- ✓ Excess Inventory Management