

High Speed Current Mode PWM

Description

The SG1825C is a high-performance pulse width modulator optimized for high frequency current-mode power supplies. Included in the controller are a precision voltage reference, micro power start-up circuitry, soft-start, high frequency oscillator, wideband error amplifier, fast current limit comparator, full double-pulse suppression logic, and dual totem pole output drivers. Innovative circuit design and an advanced linear Schottky process result in very short propagation delays through the current limit comparator, logic, and output drivers. This device can be used to implement either current mode or voltage mode switching power supplies. It also is useful as a series-resonant controller to frequencies beyond 1MHz. The SG1825C is specified for operation over the full military ambient temperature range of -55°C to 125°C.

Features

- Improved Reference Initial Tolerance ($\pm 1\%$ max.)
- Improved Oscillator Initial Accuracy ($\pm 3\%$ typ.)
- Improved Startup Current (500 μ A typ.)
- Propagation Delay to Outputs (50ns typ.)
- 10V to 30V Operation
- 5.1V Reference Trimmed to $\pm 1\%$
- 2MHz Oscillator Capability
- 1.5A Peak Totem-Pole Drivers
- U.V. Lockout with Hysteresis
- No Output Driver "FLOAT"
- Programmable Softstart
- Double-Pulse Suppression Logic
- Wideband Low-Impedance Error Amplifier
- Current-Mode or Voltage-Mode Control

High Reliability Features

- Available To MIL-STD-883 – 883, ¶ 1.2.1
- Available to DSCC
 - Standard Microcircuit Drawing (SMD)
- SGR1825C Rad-Tolerant Version Available

Product Highlight

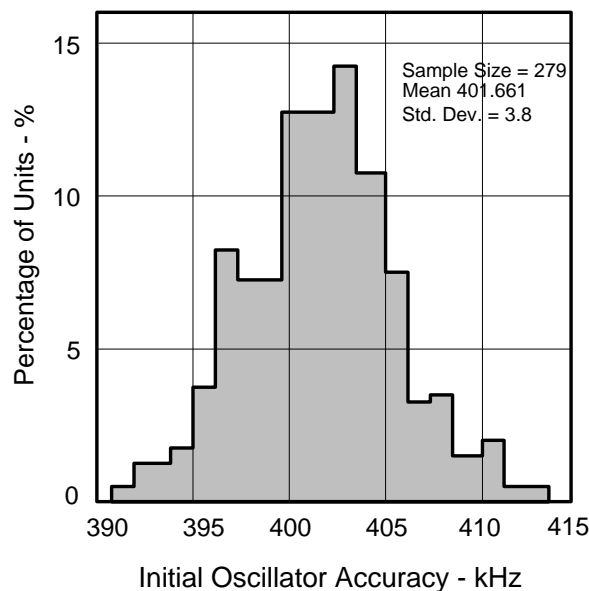
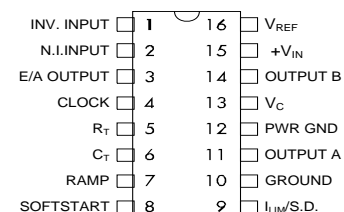
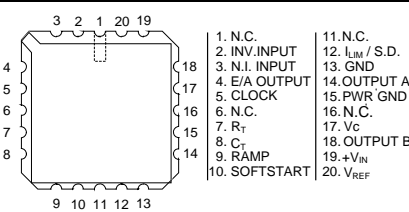

Figure 1 - Product Highlight

Connection Diagrams and Ordering Information

Ambient Temperature	Type	Package	Part Number	Packaging Type	Connection Diagram
-55°C to 125°C	J	16-PIN CERAMIC DUAL INLINE PACKAGE	SG1825CJ	CERDIP	 <p>J Package (Top View)</p>
			SG1825CJ-883B		
			SG1825CJ-DESC		
-55°C to 125°C	L	20-Pin CERAMIC Leadless Chip Carrier	SG1825CL	CLCC	 <p>L PACKAGE (Top View)</p>
			SG1825CL-883B		
			SG1825CL-DESC		
<p><i>Notes:</i></p> <ol style="list-style-type: none"> Contact factory for DESC part availability. All parts are viewed from the top. Hermetic Packages J, & L use Pb37/Sn63 hot solder lead finish, contact factory for availability of RoHS versions. 					

Absolute Maximum Ratings¹

Parameter	Value	Units
Input Voltage (V _{IN} and V _C)	30	V
Analog Inputs:		
Error Amplifier and Ramp	-0.3 to 7.0	V
Softstart and ILIM/S.D.	0.3 to 6.0	V
Digital Input (Clock)	1.5 to 6.0	V
Driver Outputs	-0.3 to V _C +1.5	V
Source / Sink Output Current (each output):		
Continuous	0.5	A
Pulse, 500ns	2.0	A
Softstart Sink Current	20	mA
Clock Output Current	5	mA
Error Amplifier Output Current	5	mA
Oscillator Charging Current	5	mA
Operating Junction Temperature:		
Hermetic (J, L Package)	150	°C
Storage Temperature Range	-65 to 150	°C
Lead Temperature (soldering, 10 seconds)	300	°C
Peak Package Solder Reflow Temp. (40 seconds max. exposure)	260 (+0, -5)	°C

Notes: 1. Exceeding these ratings could cause damage to the device.

Thermal Data

Parameter	Value	Units
J Package		
Thermal Resistance-Junction to Case, θ_{JC}	30	°C/W
Thermal Resistance-Junction to Ambient, θ_{JA}	80	°C/W
L Package		
Thermal Resistance-Junction to Case, θ_{JC}	35	°C/W
Thermal Resistance-Junction to Ambient, θ_{JA}	120	°C/W
<p>Notes:</p> <p>Junction Temperature Calculation: $T_J = T_A + (P_D \times \theta_{JA})$.</p> <p>The θ_{JA} numbers are guidelines for the thermal performance of the device/pc-board system. All of the above assume no ambient airflow.</p>		

Recommended Operating Conditions²

Symbol	Parameter	Recommended Operating Conditions			Units
		Min.	Typ.	Max.	
V _{IN}	Supply Voltage Range	10		30	V
	Voltage Amp Common Mode Range	1.5		5.5	V
	Ramp Input Voltage Range	0		5.0	V
	Current Limit I Shutdown Voltage Range	0		4.0	V
	Source / Sink Output Current:				
	Continuous		200		mA
	Pulse, 500ns		1.0		A
	Voltage Reference Output Current	1		10	mA
	Oscillator Frequency Range	4		1500	kHz
	Oscillator Charging Current	0.030		3	mA
R _T	Oscillator Timing Resistor	1		100	kΩ
C _T	Oscillator Timing Capacitor	0.470		10	nF
	Operating Ambient Temperature Range:				
T _A	SG1825C	-55		125	°C

Notes: 2. Range over which the device is functional.

Electrical Characteristics

Unless otherwise specified, these specifications apply over the full operating ambient temperatures of $-55^{\circ}\text{C} \leq T_A \leq 125^{\circ}\text{C}$ and $V_{IN} = V_C = 15\text{V}$. Low duty cycle pulse testing techniques are used which maintains junction and case temperatures equal to the ambient.

Symbol	Parameter	Test Conditions	Min.	Typ.	Max	Units
Reference Section						
	Output Voltage	$T_J = 25^{\circ}\text{C}, I_L = 1\text{mA}$	5.05	5.10	5.15	V
	Line Regulation	$V_{IN} = 10\text{V to } 30\text{V}$		2	15	mV
	Load Regulation	$I_L = 1\text{mA to } 10\text{mA}$		5	15	mV
	Temperature Stability ³	Over Operating Temperature		0.2	0.4	mV/ $^{\circ}\text{C}$
	Total Output Range ³	Over Line, Load, and Temperature	5.00		5.20	V
	Output Noise Voltage ³	$f = 10\text{Hz to } 10\text{kHz}, I_L = 0\text{mA}$		50	200	μV_{RMS}
	Long Term Stability ^{3 and 4}	$T_J = 125^{\circ}\text{C}, t = 1000 \text{ hrs}$		5	25	mV
	Short Circuit Current	$V_{\text{REF}} = 0\text{V}$	-15	-50	-100	mA
Oscillator Section⁵						
	Initial Accuracy	$T_J = 25^{\circ}\text{C}, C_{\text{CLK}} \leq 10\text{pF}$	370	400	430	kHz
	Voltage Stability	$V_{IN} = 10\text{V to } 30\text{V}$		0.2	2	%
	Temperature Stability ³	Over Rated Operating Temperature		5	8	%
	Total Frequency Limits ³	Over Line and Temperature	350		450	kHz
	Minimum Frequency	$R_T = 100\text{k}\Omega, C_T = 0.01\mu\text{F}$			4	kHz
	Maximum Frequency	$R_T = 1\text{k}\Omega, C_T = 470\text{pF}$	1.5			MHz
	Clock High Level	$I_{\text{CLK}} = -1\text{mA}$	3.9	4.5		V
	Clock Low Level	$I_{\text{CLK}} = -1\text{mA}$		2.3	2.9	V
	Ramp Peak Voltage		2.6	2.8	3.0	V
	Ramp Valley Voltage		0.7	1.0	1.25	V
	Valley-to-Peak Amplitude		1.6	1.8	2.0	V
Error Amp Section⁶						
	Input Offset Voltage	$R_S \leq 2\text{k}\Omega, V_{\text{ERROR}} = 2.5\text{V}$			15	mV
	Input Bias Current	$V_{\text{ERROR}} = 2.5\text{V}$		0.6	3	μA
	Input Offset Current	$V_{\text{ERROR}} = 2.5\text{V}$		0.1	1	μA
A_{VOL}	DC Open Loop Gain	$V_{\text{ERROR}} = 1\text{V to } 4\text{V}$	60	95		dB
	Common Mode Rejection	Over Rated Voltage Range, $V_{\text{ERROR}} = 2.5\text{V}$	75	95		dB
	Power Supply Rejection	$V_{IN} = 10\text{V to } 30\text{V}, V_{\text{ERROR}} = 2.5\text{V}$	85	110		dB
	Output Sink Current	$V_{\text{ERROR}} = 1\text{V}$	1	2.5		mA
	Output Source Current	$V_{\text{ERROR}} = 4\text{V}$	-0.5	-1.3		mA
	Output High Voltage	$I_{\text{ERROR}} = -0.5\text{mA}$	4.0	4.7	5.0	V
	Output Low Voltage	$I_{\text{ERROR}} = 1\text{mA}$	0	0.5	1.0	V
	Unity Gain Bandwidth ³	$A_{\text{VOL}} = 0\text{dB}$	3	5.5		MHz
	Slew Rate ³		6			V/ μsec

Symbol	Parameter	Test Conditions	Min.	Typ.	Max	Units
PWM Comparator Section ^{5 and 7}						
	Ramp Input Bias Current		-5	-1		μA
	Minimum Duty Cycle	V _{ERROR} = 1V			0	%
	Maximum Duty Cycle ⁸	V _{ERROR} = 4V	85			%
	Zero Duty Cycle Threshold		1.1	1.25		V
	Delay to Driver Output ³	V _{RAMP} = 0V to 2V, V _{ERROR} = 2V		50	80	ns
Softstart Section						
	C _{SS} Charge Current	V _{SOFTSTART} = 0.5V	3	9	20	μA
	C _{SS} Discharge Current	V _{SOFTSTART} = 1.0V	1			mA
Current Limit / Shutdown Section ⁹						
	I _{LIM} Input Bias Current		-15		15	μA
	Current Limit Threshold		0.9	1.0	1.1	V
	Shutdown Threshold		1.25	1.40	1.55	V
	Delay to Driver Output ³	V _{SHUTDOWN} = 0V to 1.2V		50	80	ns
Output Drivers Section (each output)						
	Output Low Level	I _{SINK} = 20mA		0.25	0.40	V
		I _{SINK} = 200mA		1.2	2.0	V
	Output High Level	I _{SOURCE} = 20mA	13.0	13.5		V
		I _{SOURCE} = 200mA	12.0	13.0		V
	V _C Standby Current	V _C = 30V		150	500	μA
	Output Rise / Fall Time ³	C _L = 1000pF		30	60	ns
Undervoltage Lockout Section						
	Start Threshold Voltage		8.8	9.2	9.7	V
	UV Lockout Hysteresis		0.4	0.8	1.2	V
Supply Current Section ⁵						
	Start Up Current	V _{IN} = 8V		0.5	1.2	mA
	Operating Current	V _{INV} , V _{RAMP} , V(I _{LIM} /S.D.) = 0V, V _{N.I.} = 1V		22	33	mA
Notes:						
3. This parameter is guaranteed by design and process control, but is not 100% tested in production.						
4. This parameter is non-accumulative, and represents the random fluctuation of the reference voltage within some error band when observed over any 1000 hour period of time.						
5. F _{OSC} = 400kHz (R _T = 3.65kΩ, C _T = 1.0nF).						
6. V _{CM} = 1.5V to 5.5V.						
7. V _{RAMP} = 0V, unless otherwise specified.						
8. 100% duty cycle is defined as a pulse width equal to one oscillator period.						
9. V(I _{LIM} /S.D.) = 0V to 4.0V, unless otherwise specified.						

Block Diagram

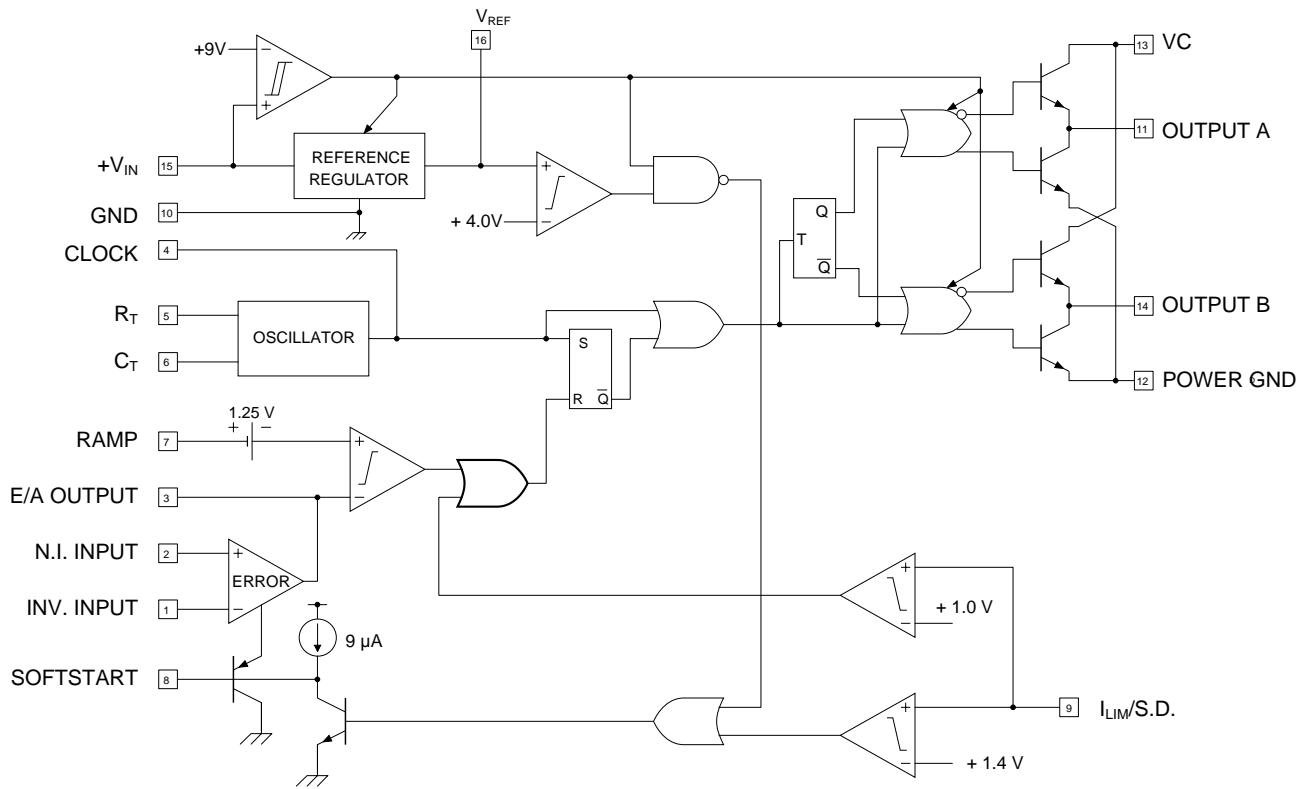

Application Information

High Speed Layout and Bypassing

The SG1825C, like all high-speed circuits, requires extra attention to external conductor and component layout to minimize undesired inductive and capacitive effects. All lead lengths must be as short as possible. The best printed circuit board choice would be a four-layer design, with the two internal planes supplying power and ground. Signal interconnects should be placed on the outside, giving a conductor-over-ground-plane (microstrip) configuration. A two-sided printed circuit board with one side dedicated as a ground plane is next best, and requires careful component placement by a skilled pc designer. Two supply bypass capacitors should be employed: a low-inductance $0.1\mu\text{F}$ ceramic within 0.25 inches of the $+V_{\text{IN}}$ pin for high frequencies, and a $1\mu\text{F}$ to $5\mu\text{F}$ solid tantalum within 0.5 inches of the VC pin to provide an energy reservoir for the high-peak output currents. A low-inductance $.01\mu\text{F}$ bypass for the reference output is also recommended.

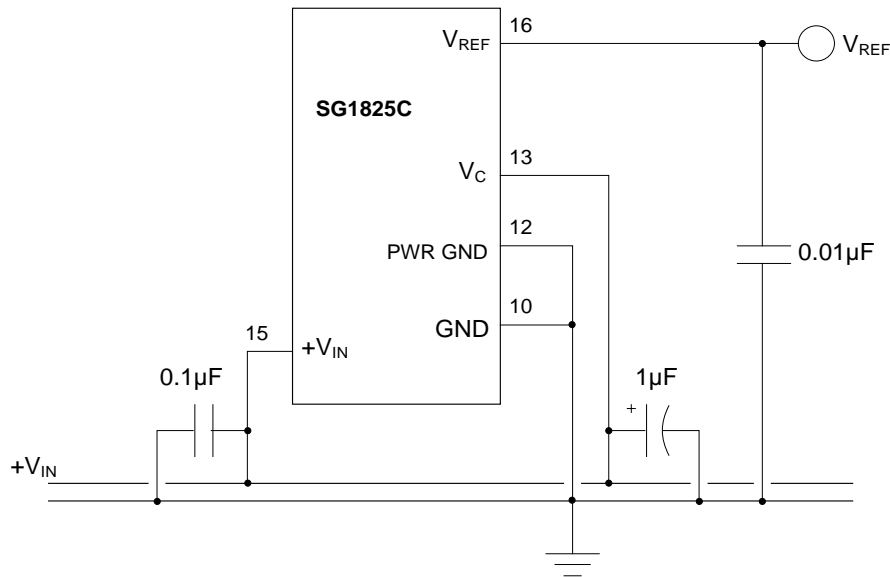

Figure 4 - High Speed Layout and Bypassing

Micropower Startup

Since the SG1825C typically draws 700 μ A of supply current before turning on, a low power bleeder resistor from the rectified AC line supply is all that is required for startup. A start capacitor, CS, is charged with the excess current from the bleeder resistor. When the turn-on threshold voltage is reached, the PWM circuit becomes active, energizing the power transistors. The additional operating current required by the PWM is then provided by a bootstrap winding on the main high-frequency power transformer.

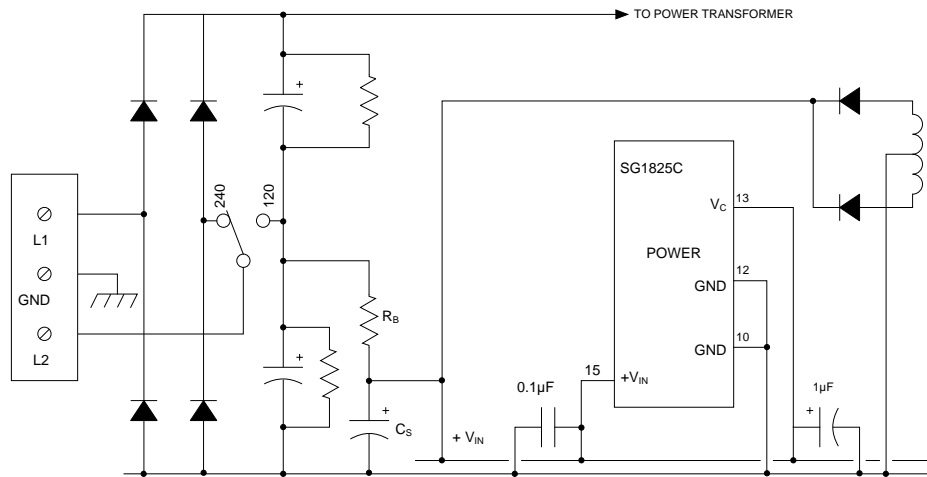

Figure 5 - Micropower Startup

Softstart Circuit / Output Duty Cycle Limit

The softstart pin of the SG1825C is held low when either the chip is in micropower mode, or when a voltage greater than +1.4 volts is present at the $I_{LIM/S.D.}$ pin. The maximum positive swing of the voltage error amplifier is clamped to the Softstart pin voltage, providing a ramp-up of peak charging currents in the power semiconductors at turn-on. In some cases, the duration of the Shutdown signal can be too short to fully discharge the softstart capacitor. The illustrated resistor/discrete PNP transistor configuration can be used to shorten the discharge time by a factor of 50 or more. When the internal discharge transistor in the SG1825C turns on, current will flow through surge limit resistor R1. As the resistor drop approaches 0.6 volts, the external PNP transistor turns on, providing a low resistance discharge path for the energy in the softstart capacitor. The capacitor will be rapidly discharged to +0.7 volts, which corresponds to zero duty cycle in the pulse width modulator.

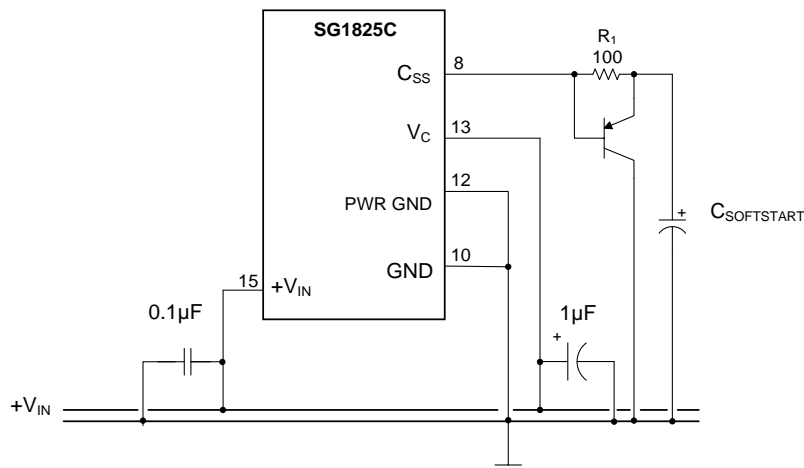

Figure 6 - Softstart Fast Reset

Frequency Synchronization

Two or three SG1825C oscillators may be locked together with the interconnection scheme shown, if the devices are within an inch or so of each other. A master unit is programmed for desired frequency with R_T and C_T as usual. The oscillators in the slave units are disabled by grounding C_T and by connecting R_T to V_{REF} . The logic in the slave units is locked to the clock of the master with the wire-OR connection shown. Many SG1825Cs can be locked to a master system clock by wiring the oscillators as slave units, and distributing the master clock to each using a tree-fan-out geometry.

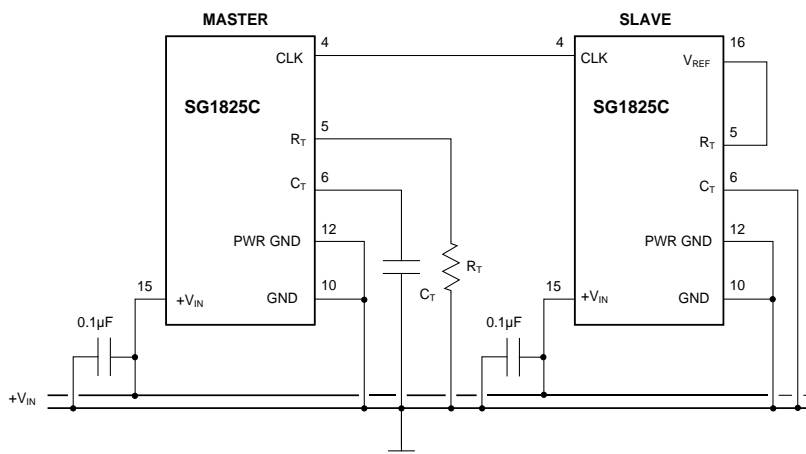

Figure 7 - Oscillator Synchronization

Oscillator

The oscillator frequency is programmed by external timing components R_T and C_T . A nominal +3.0 volts appears at the R_T pin. The current flowing through R_T is mirrored internally with a 1:1 ratio. This causes an identical current to flow out the C_T pin, charging the timing capacitor and generating a linear ramp. When the upper threshold of +2.8 volts is reached, a discharge network reduces the ramp voltage to +1.0, where a new charge cycle begins. The Clock output pin is LOW (+2.3 volts) during the charge cycle, and HIGH (+4.5 volts) during the discharge cycle. The Clock pin is driven by an NPN emitter follower, and so can be wire-ORed. Each Clock pin can drive a 1 mA load. Since the internal current-source pull-down is approximately 400µA, the DC fan-out to other SG1825C Clock pins is at least two.

The type of capacitor selected for C_T is very important. At high frequencies, non-ideal characteristics such as effective series resistance (ESR), effective series inductance (ESL), dielectric loss and dielectric absorption all affect frequency accuracy and stability. RF capacitors such as silver mica, glass, polystyrene, or COG ceramics are recommended. Avoid high-K ceramics, which work best in DC bypass applications.

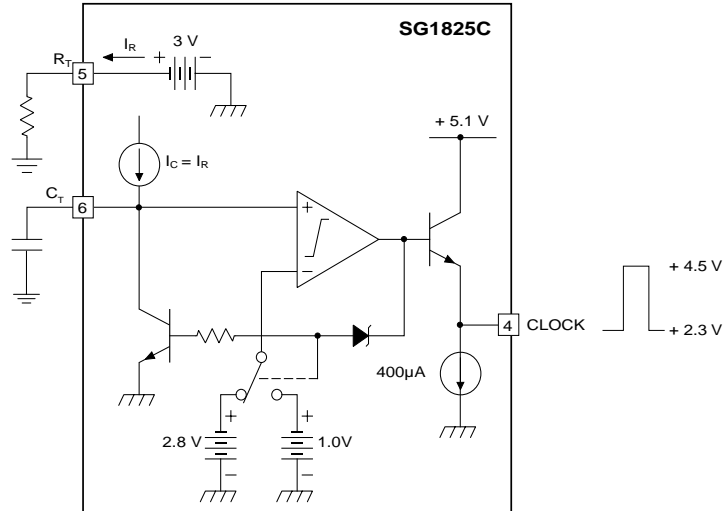

Figure 8 - Oscillator Functional Diagram

Error Amplifier

The voltage error amplifier is a true operational amplifier with low impedance output, and can be gain-stabilized using conventional feedback techniques. The typical DC open-loop gain is 95dB, with a single low frequency pole at 100Hz. The input connections to the error amplifier are determined by the polarity of the power supply output voltage. For positive supplies, the common-mode voltage is +5.1 volts and the feedback connections in Figure A are used. With negative outputs, the common-mode voltage is half the reference, and the feedback divider is connected between the negative output and the +5.1 volt reference as shown in Figure B.

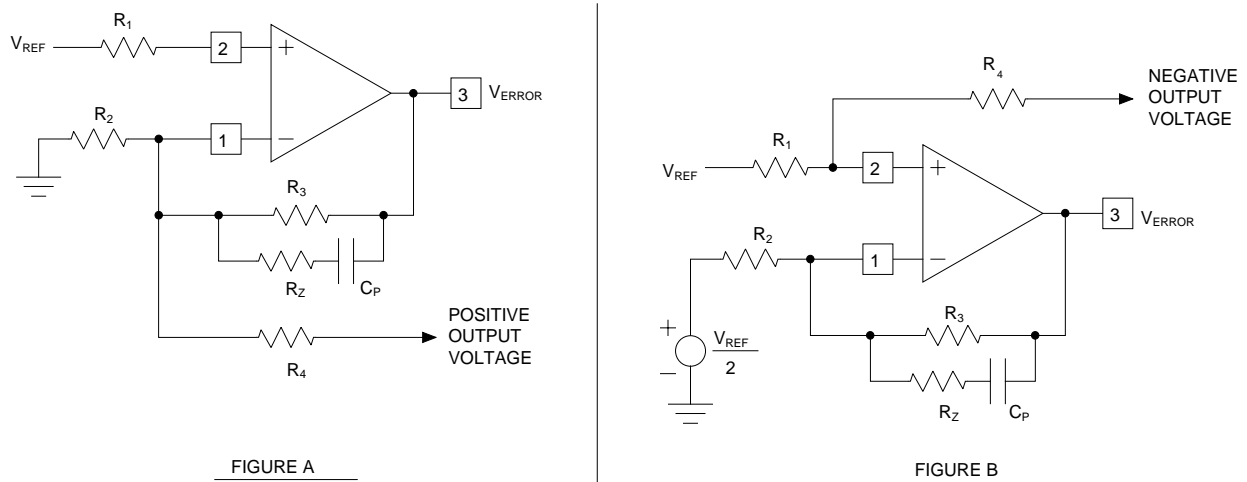

Figure 9 • Voltage Amplifier Connections

Output Driver

The output drivers are designed to provide up to 1.5 Amps peak output current. To minimize ringing on the output waveform, which can be destructive to both the power MOSFET and the PWM chip, the series inductance seen by the drivers should be as low as possible. One solution is to keep the distance between the PWM and MOSFET gate as short as possible, and to use carbon composition series damping resistors. A Faraday shield to intercept radiated EMI from the power transistors is usually required with its choice. A second approach is to place the MOSFETs some distance from the PWM chip, and use a series-terminated transmission line to preserve drive pulse fidelity. This will minimize noise radiated back to the sensitive analog circuitry of the SG1825C. A Faraday shield may also be required. If the drivers are connected to an isolation transformer, or if kickback through C_{GD} of the MOSFET is severe, clamp diodes may be required. 1 Amp peak Schottky diodes will limit undershoot to less than -0.3 volts.

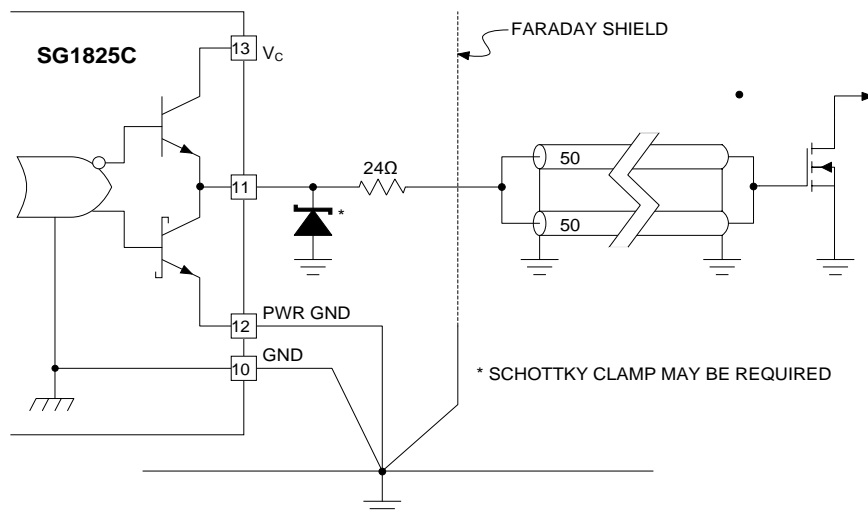
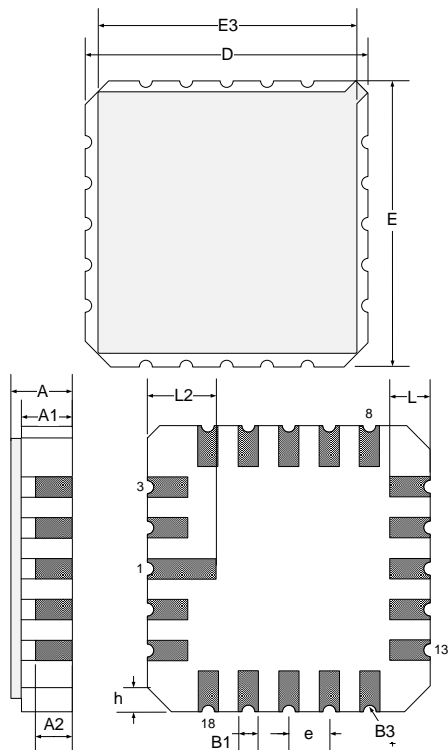

Figure 10 • Driving Shielded Cable

Package Outline Dimensions

Controlling dimensions are in millimeters, inches are shown for general information.



Dim	MILLIMETERS		INCHES	
	MIN	MAX	MIN	MAX
D/E	8.64	9.14	0.340	0.360
E3	-	8.128	-	0.320
e	1.270 BSC		0.050 BSC	
B1	0.635 TYP		0.025 TYP	
L	1.02	1.52	0.040	0.060
A	1.626	2.286	0.064	0.090
h	1.016 TYP		0.040 TYP	
A1	1.372	1.68	0.054	0.066
A2	-	1.168	-	0.046
L2	1.91	2.41	0.075	0.95
B3	0.203R		0.008R	

Note:

- All exposed metalized area shall be gold plated 60 micro-inch minimum thickness over nickel plated unless otherwise specified in purchase order.

Figure 11 - L 20-Pin Ceramic Leadless Chip Carrier (LCC) Package Outline Dimensions

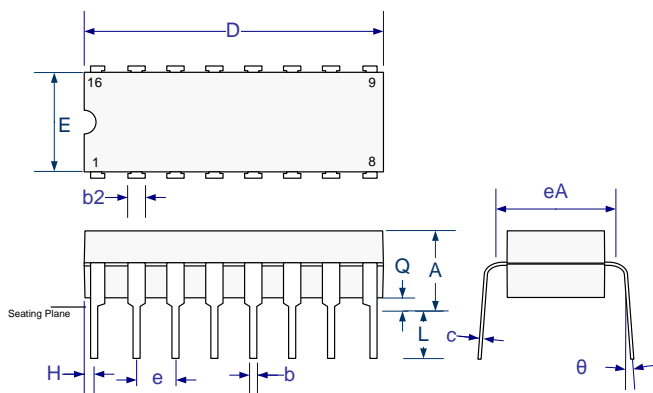

Dim	MILLIMETERS		INCHES	
	MIN	MAX	MIN	MAX
A		5.08		0.200
b	0.38	0.51	0.015	0.020
b2	1.04	1.65	0.045	0.065
c	0.20	0.38	0.008	0.015
D	19.30	19.94	0.760	0.785
E	5.59	7.11	0.220	0.280
e	2.54 BSC		0.100 BSC	
eA	7.37	7.87	0.290	0.310
H	0.63	1.78	0.025	0.070
L	3.18	5.08	0.125	0.200
alpha	-	15°	-	15°
Q	0.51	1.02	0.020	0.040

Note:

- Dimensions do not include protrusions; these shall not exceed 0.155mm (.006") on any side. Lead dimension shall not include solder coverage.

Figure 12 - J 16-Pin Ceramic Dual Inline Package Dimensions



Microsemi Corporate Headquarters

One Enterprise, Aliso Viejo,
CA 92656 USA

Within the USA: +1 (800) 713-4113

Outside the USA: +1 (949) 380-6100

Sales: +1 (949) 380-6136

Fax: +1 (949) 215-4996

E-mail: sales.support@microsemi.com



© 2014 Microsemi Corporation. All rights reserved. Microsemi and the Microsemi logo are trademarks of Microsemi Corporation. All other trademarks and service marks are the property of their respective owners.

Microsemi Corporation (Nasdaq: MSCC) offers a comprehensive portfolio of semiconductor and system solutions for communications, defense & security, aerospace and industrial markets. Products include high-performance and radiation-hardened analog mixed-signal integrated circuits, FPGAs, SoCs and ASICs; power management products; timing and synchronization devices and precise time solutions, setting the world's standard for time; voice processing devices; RF solutions; discrete components; security technologies and scalable anti-tamper products; Power-over-Ethernet ICs and midspans; as well as custom design capabilities and services. Microsemi is headquartered in Aliso Viejo, Calif., and has approximately 3,400 employees globally. Learn more at www.microsemi.com.

Microsemi makes no warranty, representation, or guarantee regarding the information contained herein or the suitability of its products and services for any particular purpose, nor does Microsemi assume any liability whatsoever arising out of the application or use of any product or circuit. The products sold hereunder and any other products sold by Microsemi have been subject to limited testing and should not be used in conjunction with mission-critical equipment or applications. Any performance specifications are believed to be reliable but are not verified, and Buyer must conduct and complete all performance and other testing of the products, alone and together with, or installed in, any end-products. Buyer shall not rely on any data and performance specifications or parameters provided by Microsemi. It is the Buyer's responsibility to independently determine suitability of any products and to test and verify the same. The information provided by Microsemi hereunder is provided "as is, where is" and with all faults, and the entire risk associated with such information is entirely with the Buyer. Microsemi does not grant, explicitly or implicitly, to any party any patent rights, licenses, or any other IP rights, whether with regard to such information itself or anything described by such information. Information provided in this document is proprietary to Microsemi, and Microsemi reserves the right to make any changes to the information in this

Looking for pricing, stock, or lifecycle information?

Click below to explore more details on WIN SOURCE:

-  [View SG1825CJ on WIN SOURCE](#)
-  [Microsemi Corporation](#) Information

Optimize Your Supply Chain with WIN SOURCE Solutions

-  Global Sourcing Solution
-  Obsolete Management
-  Cost Control Management
-  Shortage Management
-  Alternative Solution
-  Excess Inventory Management