

SGx524 Regulating Pulse-Width Modulators

1 Features

- Complete Pulse-Width Modulation (PWM) power-control circuitry
- Uncommitted outputs for single-ended or push-pull applications
- 8-mA (TYP) standby current

2 Applications

- Transformer-coupled DC/DC convertors
- Switching-regulators of any polarity

3 Description

The SG2524 and SG3524 devices incorporate all the functions required in the construction of a regulating power supply, inverter, or switching regulator on a single chip. They also can be used as the control element for high-power-output applications. The SG2524 and SG3524 were designed for switching regulators of either polarity, transformer-coupled dc-to-dc converters, transformerless voltage doublers, and polarity-converter applications employing fixed-frequency, pulse-width modulation (PWM) techniques. The complementary output allows either single-ended or push-pull application. Each device includes an on-chip regulator, error amplifier, programmable oscillator, pulse-steering flip-flop, two uncommitted pass transistors, a high-gain comparator, and current-limiting and shutdown circuitry.

Device Information

PART NUMBER	PACKAGE (PIN)	BODY SIZE (NOM)
SGx524	SOIC (16)	9.90 mm × 3.91 mm
	PDIP (16)	9.90 mm × 6.35 mm
	NS (16)	10.30 mm × 5.30 mm

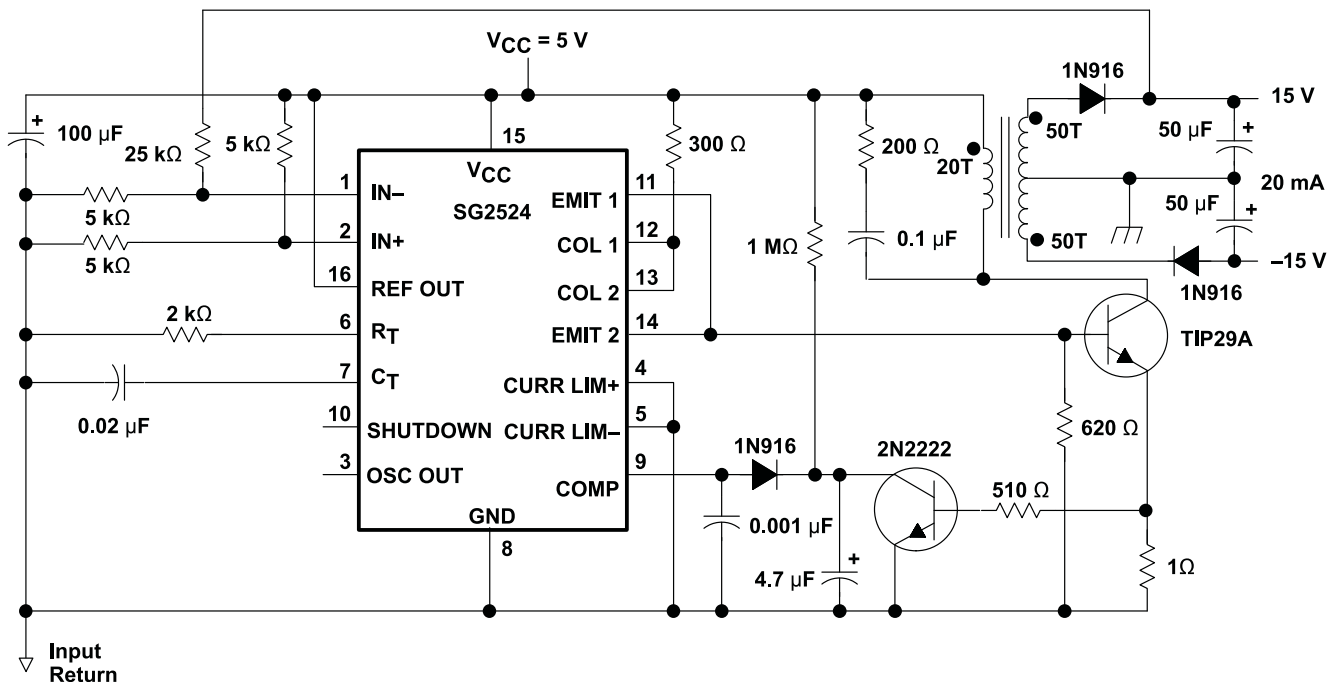

Typical Application Schematic

Table of Contents

1 Features	1	7.3 Typical Characteristics.....	7
2 Applications	1	8 Parameter Measurement Information	8
3 Description	1	8.1	8
4 Revision History	2	9 Detailed Description	9
5 Pin Configurations and Functions	2	9.1 Overview.....	9
Pin Functions.....	2	9.2 Functional Block Diagram.....	9
6 Specifications	4	9.3 Feature Description.....	10
6.1 Absolute Maximum Ratings.....	4	9.4 Device Functional Modes.....	11
6.2 ESD Ratings.....	4	10 Layout	19
6.3 Recommended Operating Conditions.....	4	10.1 Layout Guidelines.....	19
6.4 Thermal Information.....	4	10.2 Layout Example.....	20
7	5	11 Device and Documentation Support	21
7.1 Electrical Characteristics.....	5	11.1 Related Links.....	21
7.2 Electrical Characteristics — Continued, Both Parts....	6	11.2 Trademarks.....	21

4 Revision History

Changes from Revision E (January 2015) to Revision F (February 2021)	Page
• Updated text.....	6

Changes from Revision D (February 2003) to Revision E (January 2015)	Page
• Added <i>Applications</i> , <i>Device Information</i> table, <i>Pin Functions</i> table, <i>ESD Ratings</i> table, <i>Thermal Information</i> table, <i>Typical Characteristics</i> , <i>Feature Description</i> section, <i>Device Functional Modes</i> , <i>Application and Implementation</i> section, <i>Power Supply Recommendations</i> section, <i>Layout</i> section, <i>Device and Documentation Support</i> section, and <i>Mechanical, Packaging, and Orderable Information</i> section.....	1
• Deleted <i>Ordering Information</i> table.....	1

5 Pin Configurations and Functions

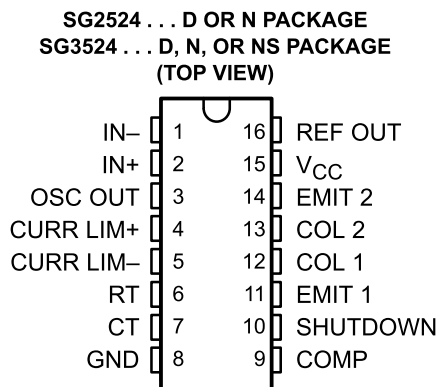

Pin Functions

PIN		TYPE	DESCRIPTION
NAME	NO.		
COL 1	12	O	Collector terminal of BJT output 1
COL 2	13	O	Collector terminal of BJT output 2
COMP	9	I/O	Error amplifier compensation pin
CT	7	—	Capacitor terminal used to set oscillator frequency
CURR LIM+	4	I	Positive current limiting amplifier input
CURR LIM-	5	I	Negative current limiting amplifier input

PIN		TYPE	DESCRIPTION
NAME	NO.		
EMIT 1	11	O	Emitter terminal of BJT output 1
EMIT 2	14	O	Emitter terminal of BJT output 2
GND	8	—	Ground
IN+	2	I	Positive error amplifier input
IN-	1	I	Positive error amplifier input
OSC OUT	3	O	Oscillator Output
REF OUT	16	O	Reference regulator output
RT	6	—	Resistor terminal used to set oscillator frequency
SHUTDOWN	10	I	Device shutdown
V _{CC}	15	—	Positive supply

6 Specifications

6.1 Absolute Maximum Ratings

over operating free-air temperature range (unless otherwise noted)⁽¹⁾

		MIN	MAX	UNIT
V _{CC}	Supply voltage		40	V
I _{CC}	Collector output current		100	mA
I _{O(ref)}	Reference output current		50	mA
	Current through CT terminal	-5		mA
T _J	Maximum junction temperature		150	°C
	Lead temperature 1,6 mm (1/16 inch) from case for 10 seconds		260	°C
T _{stg}	Storage temperature range	-65	150	°C

- (1) Stresses beyond those listed under [Section 6.1](#) table may cause permanent damage to the device. These are stress ratings only, and functional operation of the device at these or any other conditions beyond those indicated under [Section 6.3](#) table are not implied. Exposure to absolute-maximum-rated conditions for extended periods may affect device reliability.

6.2 ESD Ratings

			VALUE	UNIT
V _(ESD)	Electrostatic discharge	Human body model (HBM), per ANSI/ESDA/JEDEC JS-001, all pins ⁽¹⁾	1000	V
		Charged device model (CDM), per JEDEC specification JESD22-C101, all pins ⁽²⁾	1000	

- (1) JEDEC document JEP155 states that 500-V HBM allows safe manufacturing with a standard ESD control process.
 (2) JEDEC document JEP157 states that 250-V CDM allows safe manufacturing with a standard ESD control process.

6.3 Recommended Operating Conditions

over operating free-air temperature range (unless otherwise noted)

			MIN	MAX	UNIT
V _{CC}	Supply Voltage		8	40	V
	Reference output current		0	50	mA
	Current through CT terminal		-0.03	-2	mA
R _T	Timing resistor		1.8	100	kΩ
C _T	Timing capacitor		0.001	0.1	μF
T _A	Operating free-air temperature	SG2524	-25	85	°C
		SG3524	0	70	

6.4 Thermal Information

THERMAL METRIC ⁽¹⁾	SGx524			UNIT	
	D	N	NS		
	16 PINS				
R _{θJA}	Junction-to-ambient thermal resistance ^{(2) (3)}	73	67	64	°C/W

- (1) For more information about traditional and new thermal metrics, see the *IC Package Thermal Metrics* application report, [SPRA953](#).
 (2) Maximum power dissipation is a function of T_{J(max)}, θ_{JA}, and T_A. The maximum allowable power dissipation at any allowable ambient temperature is PD = (T_{J(max)} – T_A)/θ_{JA}. Operation at the absolute maximum T_J of 150°C can impact reliability.
 (3) The package thermal impedance is calculated in accordance with JESD 51-7.

7

7.1 Electrical Characteristics

over operating free-air temperature range, $V_{CC} = 20\text{ V}$, $f = 20\text{ kHz}$ (unless otherwise noted)

PARAMETER	TEST CONDITIONS ⁽²⁾	SG2524			SG3524			UNIT
		MIN	TYP ⁽²⁾	MAX	MIN	TYP ⁽¹⁾	MAX	
Reference section								
Output voltage		4.8	5	5.2	4.6	5	5.4	V
Input Regulation	$V_{CC} = 8\text{ V to }40\text{ V}$		10	20		10	30	mV
Ripple rejection	$f = 120\text{ Hz}$		66			66		dB
Output regulation	$I_O = 0\text{ mA to }20\text{ mA}$		20	50		20	50	mV
Output voltage change with temperature	$T_A = \text{MIN to MAX}$		0.3%	1%		0.3%	1%	
Short-circuit output current ⁽³⁾	$V_{ref} = 0$		100			100		mA
Error Amplifier section								
V_{IO} Input offset voltage	$V_{IC} = 2.5\text{ V}$		0.5	5		2	10	mV
I_{IB} Input bias current	$V_{IC} = 2.5\text{ V}$		2	10		2	10	μA
Open-loop voltage amplification		72	80		60	80		dB
V_{ICR} Common-mode input voltage range	$T_A = 25^\circ\text{C}$	1.8 to 3.4			1.8 to 3.4			V
CMMR Common-mode rejection ratio			70			70		dB
B_1 Unity-gain bandwidth			3			3		MHz
Output swing	$T_A = 25^\circ\text{C}$	0.5		3.8	0.5		3.8	V

- (1) All typical values, except for temperature coefficients, are at $T_A = 25^\circ\text{C}$.
- (2) For conditions shown as MIN or MAX, use the appropriate value specified under recommended operating conditions.
- (3) Standard deviation is a measure of the statistical distribution about the mean, as derived from the formula:

$$\sigma = \sqrt{\frac{\sum_{n=1}^N (x_n - \bar{x})^2}{N-1}}$$

7.2 Electrical Characteristics — Continued, Both Parts

over operating free-air temperature range, $V_{CC} = 20\text{ V}$, $f = 20\text{ kHz}$ (unless otherwise noted)

PARAMETER		TEST CONDITIONS ⁽²⁾	MIN	TYP ⁽¹⁾	MAX	UNIT
Oscillator section						
f_{OSC}	Oscillator frequency	$C_T = 0.001\ \mu\text{F}$, $R_T = 2\ \text{k}\Omega$		450		kHz
	Standard deviation of frequency ⁽³⁾	All values of voltage, temperature, resistance, and capacitance constant		5		—
Δf_{OSC}	Frequency change with voltage	$V_{CC} = 8\ \text{V}$ to $40\ \text{V}$, $T_A = 25^\circ\text{C}$			1%	—
	Frequency change with temperature	$T_A = \text{MIN}$ to MAX			2%	—
	Output amplitude at OSC OUT	$T_A = 25^\circ\text{C}$		3.5		V
t_W	Output pulse duration (width) at OSC OUT	$C_T = 0.01\ \mu\text{F}$, $T_A = 25^\circ\text{C}$		0.5		μs
Output section						
$V_{(BR)CE}$	Collector-emitter breakdown voltage		40			V
	Collector off-state current	$V_{CE} = 40\ \text{V}$		0.01	50	μA
V_{sat}	Collector-emitter saturation voltage	$I_C = 50\ \text{mA}$		1	2	V
V_O	Emitter output voltage	$V_C = 20\ \text{V}$, $I_E = -250\ \mu\text{A}$	17	18		V
t_r	Turn-off voltage rise time	$R_C = 2\ \text{k}\Omega$		0.2		μs
t_f	Turn-on voltage fall time	$R_C = 2\ \text{k}\Omega$		0.1		μs
Comparator section						
	Maximum duty cycle, each output		45%			
V_{IT}	Input threshold voltage at COMP	Zero duty cycle		1		V
		Maximum duty cycle		3.5		
I_{IB}	Input bias current			-1		μA
Current limiting section						
V_I	Input voltage range		-1		1	V
$V_{(SENSE)}$	Sense voltage at $T_A = 25^\circ\text{C}$	$V_{(IN+)} - V_{(IN-)} \geq 50\ \text{mV}$, $V_{(COMP)} = 2\ \text{V}$	175	200	225	mV
	Temperature coefficient of sense voltage			0.2		$\text{mV}/^\circ\text{C}$
Total Device						
I_{st}	Standby current	$V_{CC} = 40\ \text{V}$, I_{N-} , CURR LIM+, C_T , GND, COMP, EMIT 1, EMIT 2 grounded, I_{N+} at $2\ \text{V}$, All other inputs and outputs open		8	10	mA

7.3 Typical Characteristics

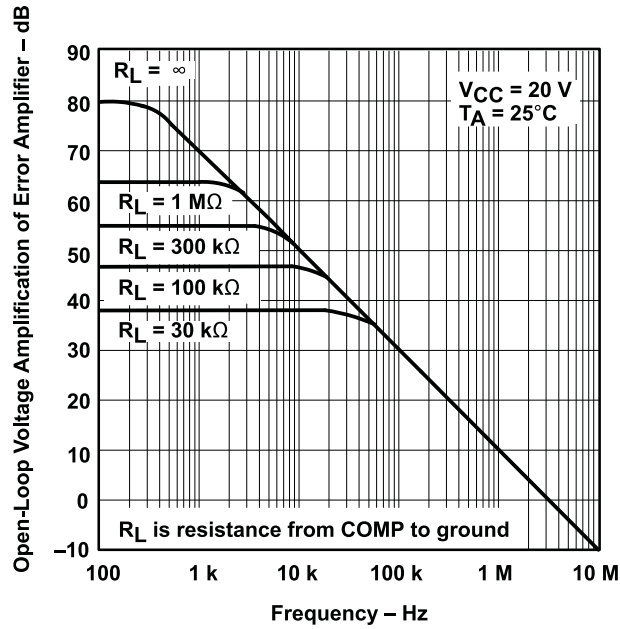

Figure 7-1. Open-Loop Voltage Amplification of Error Amplifier vs Frequency

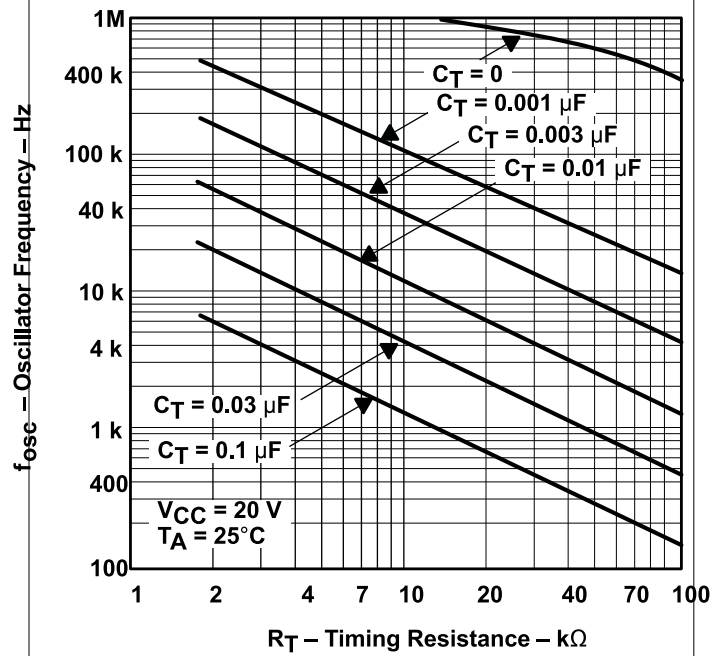

Figure 7-2. Oscillator Frequency vs Timing Resistance

8 Parameter Measurement Information

8.1

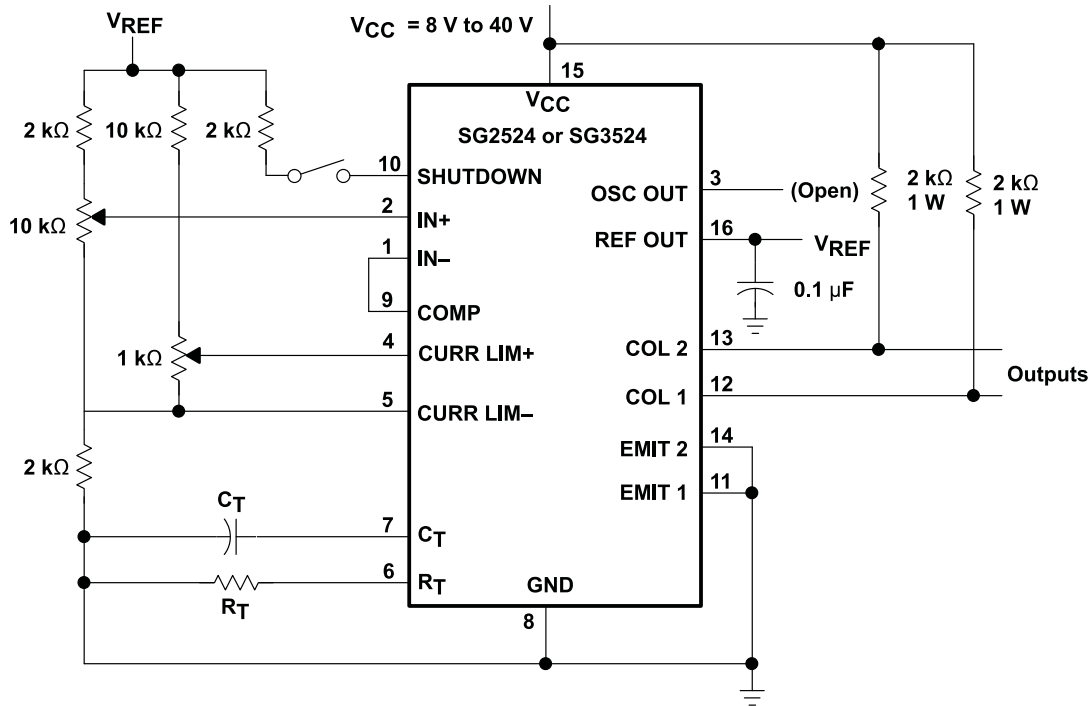

Figure 8-1. General Test Circuit

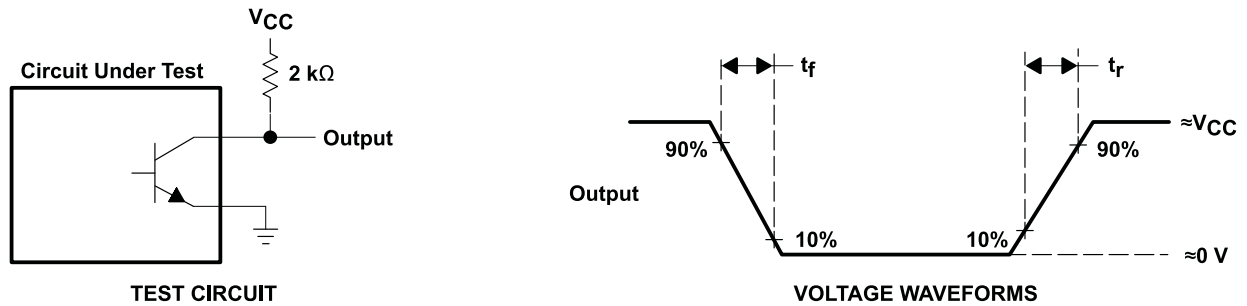

Figure 8-2. Switching Times

9 Detailed Description

9.1 Overview

SGx524 is a fixed-frequency pulse-width-modulation (PWM) voltage-regulator control circuit. The regulator operates at a fixed frequency that is programmed by one timing resistor, R_T , and one timing capacitor, C_T . R_T establishes a constant charging current for C_T . This results in a linear voltage ramp at C_T , which is fed to the comparator, providing linear control of the output pulse duration (width) by the error amplifier.

The SGx524 contains an onboard 5-V regulator that serves as a reference, as well as supplying the SGx524 internal regulator control circuitry. The internal reference voltage is divided externally by a resistor ladder network to provide a reference within the common-mode range of the error amplifier as shown in Figure 10-5, or an external reference can be used.

The output is sensed by a second resistor divider network and the error signal is amplified. This voltage is then compared to the linear voltage ramp at C_T . The resulting modulated pulse out of the high-gain comparator is then steered to the appropriate output pass transistor (Q1 or Q2) by the pulse-steering flip-flop, which is synchronously toggled by the oscillator output. The oscillator output pulse also serves as a blanking pulse to ensure both outputs are never on simultaneously during the transition times. The duration of the blanking pulse is controlled by the value of C_T .

The outputs may be applied in a push-pull configuration in which their frequency is one-half that of the base oscillator, or paralleled for single-ended applications in which the frequency is equal to that of the oscillator. The output of the error amplifier shares a common input to the comparator with the current-limiting and shut-down circuitry and can be overridden by signals from either of these inputs. This common point is pinned out externally via the COMP pin, which can be employed to either control the gain of the error amplifier or to compensate it. In addition, the COMP pin can be used to provide additional control to the regulator.

9.2 Functional Block Diagram

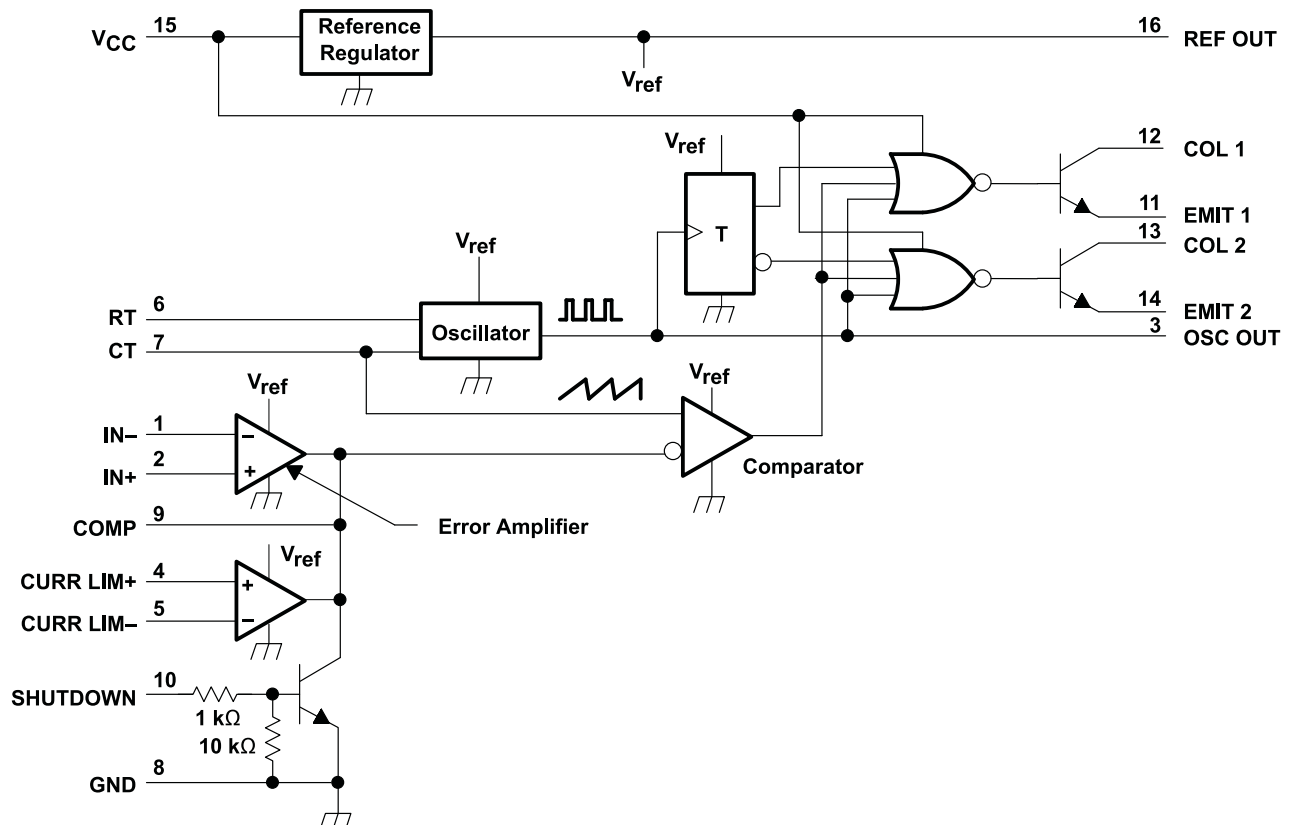

A. Resistor values shown are nominal.

9.3 Feature Description

9.3.1 Blanking

The output pulse of the oscillator is used as a blanking pulse at the output. This pulse duration is controlled by the value of C_T as shown in Figure 7-2. If small values of C_T are required, the oscillator output pulse duration can be maintained by applying a shunt capacitance from OSC OUT to ground.

9.3.2 Error Amplifier

The error amplifier is a differential-input transconductance amplifier. The output is available for DC gain control or AC phase compensation. The compensation node (COMP) is a high-impedance node ($R_L = 5\text{ M}\Omega$). The gain of the amplifier is $AV = (0.002\ \Omega^{-1})R_L$ and easily can be reduced from a nominal 10,000 by an external shunt resistance from COMP to ground. Refer to Figure 7-1 for data.

9.3.3 Compensation

COMP, as previously discussed, is made available for compensation. Since most output filters introduce one or more additional poles at frequencies below 200 Hz, which is the pole of the uncompensated amplifier, introduction of a zero to cancel one of the output filter poles is desirable. This can be accomplished best with a series RC circuit from COMP to ground in the range of 50 k Ω and 0.001 μF . Other frequencies can be canceled by use of the formula $f \approx 1/RC$.

9.3.4 Output Circuitry

SGx524 contains two identical npn transistors, the collectors and emitters of which are uncommitted. Each transistor has antisaturation circuitry that limits the current through that transistor to a maximum of 100 mA for fast response.

9.3.5 Current Limiting

A current-limiting sense amplifier is provided in the SGx524 device. The current-limiting sense amplifier exhibits a threshold of 200 mV \pm 25 mV and must be applied in the ground line since the voltage range of the inputs is limited to 1 V to -1 V . Caution should be taken to ensure the -1 V limit is not exceeded by either input, otherwise, damage to the device may result.

Foldback current limiting can be provided with the network shown in Figure 9-1. The current-limit schematic is shown in Figure 9-2.

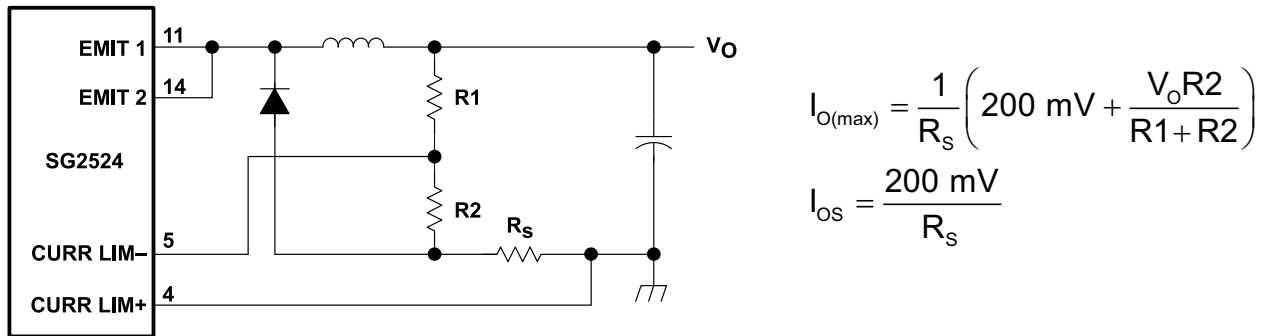

Figure 9-1. Foldback Current Limiting for Shorted Output Conditions

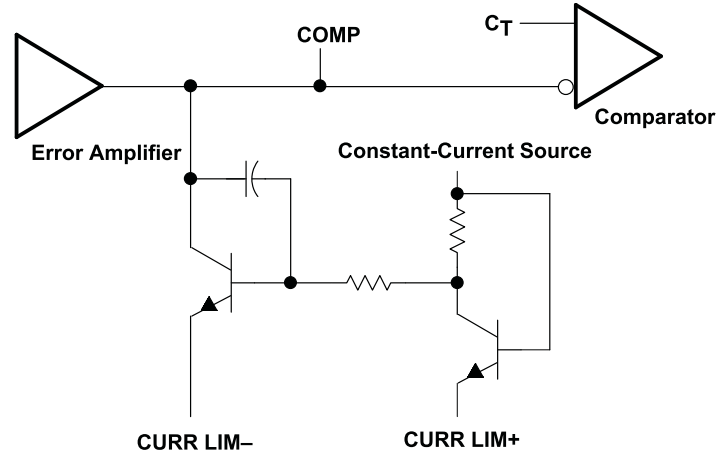

Figure 9-2. Current-Limit Schematic

9.4 Device Functional Modes

9.4.1 Synchronous Operation

When an external clock is desired, a clock pulse of approximately 3 V can be applied directly to the oscillator output terminal. The impedance to ground at this point is approximately 2 k Ω . In this configuration, $R_T C_T$ must be selected for a clock period slightly greater than that of the external clock.

If two or more SGx524 regulators are operated synchronously, all oscillator output terminals must be tied together. The oscillator programmed for the minimum clock period is the master from which all the other SGx524s operate. In this application, the $C_T R_T$ values of the slaved regulators must be set for a period approximately 10% longer than that of the master regulator. In addition, C_T (master) = 2 C_T (slave) to ensure that the master output pulse, which occurs first, has a longer pulse duration and, subsequently, resets the slave regulators.

9.4.2 Shutdown Circuitry

COMP also can be employed to introduce external control of the SGx524. Any circuit that can sink 200 μ A can pull the compensation terminal to ground and, thus, disable the SGx524.

In addition to constant-current limiting, CURR LIM+ and CURR LIM- also can be used in transformer-coupled circuits to sense primary current and shorten an output pulse should transformer saturation occur. CURR LIM- also can be grounded to convert CURR LIM+ into an additional shutdown terminal.

Application and Implementation

Note

Information in the following applications sections is not part of the TI component specification, and TI does not warrant its accuracy or completeness. TI's customers are responsible for determining suitability of components for their purposes. Customers should validate and test their design implementation to confirm system functionality.

10.1 Application Information

There are a wide variety of output configurations possible when considering the application of the SG2524 as a voltage-regulator control circuit. They can be segregated into three basic categories:

- Capacitor-diode-coupled voltage multipliers
- Inductor-capacitor-implemented single-ended circuits
- Transformer-coupled circuits

Examples of these categories are shown in [Figure 10-1](#), [Figure 10-2](#), and [Figure 10-3](#), respectively. [Section 10.2](#) demonstrates how to set up the SG2524 for a capacitor-diode output design. The same techniques for setting up the internal circuitry of the IC may also be used for the other two output stage examples shown [Section 10.3](#).

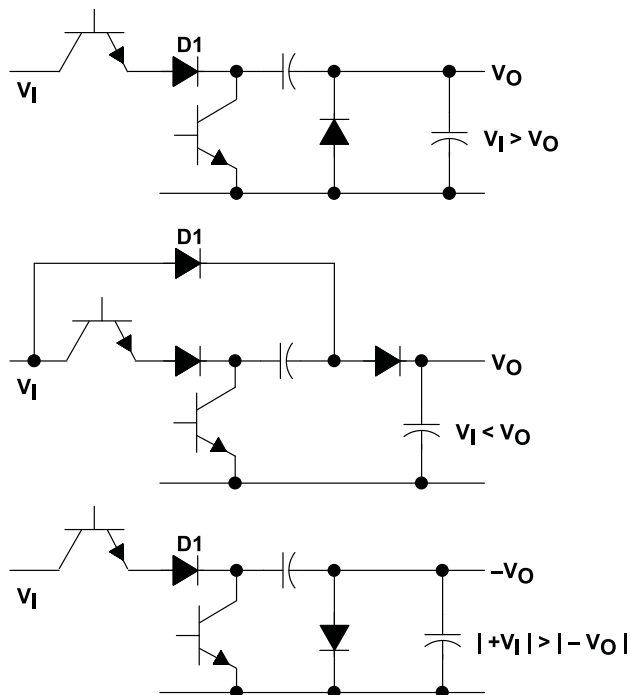

Figure 10-1. Capacitor-Diode-Coupled Voltage-Multiplier Output Stages

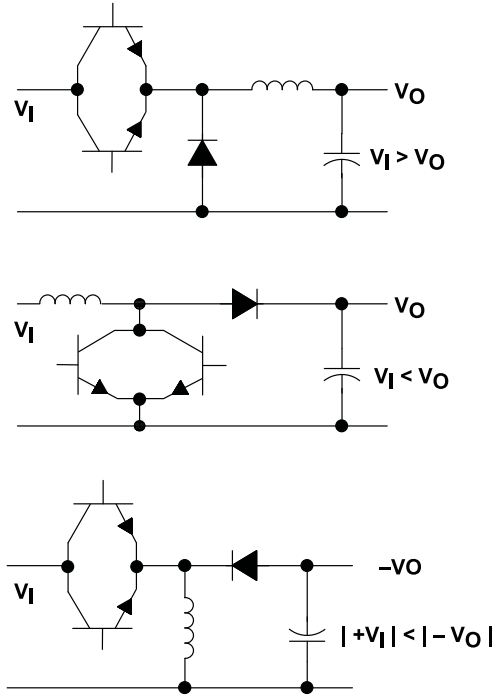

Figure 10-2. Single-Ended Inductor Circuit

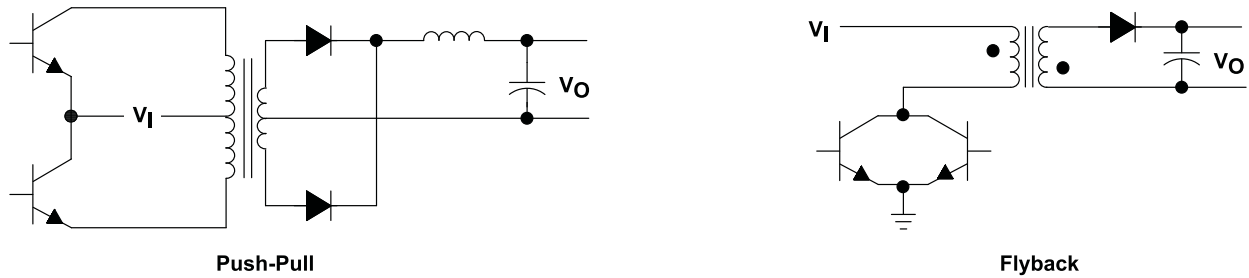

Figure 10-3. Transformer-Coupled Outputs

10.2 Typical Application

10.2.1 Capacitor-Diode Output

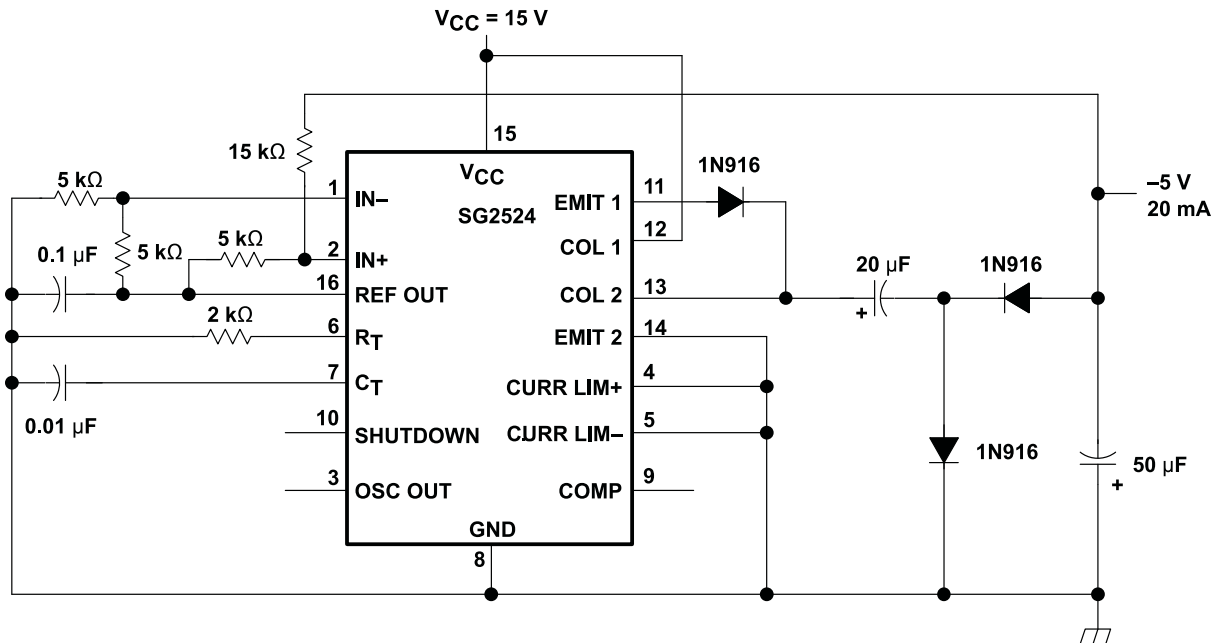

Figure 10-4. Capacitor-Diode Output Circuit Schematic

10.2.1.1 Design Requirements

- 15-V supply voltage
- -5-V output voltage

10.2.1.2 Detailed Design Procedure

10.2.1.2.1 Oscillator

The oscillator controls the frequency of the SG2524 and is programmed by R_T and C_T as shown in [Figure 10-6](#).

$$f \approx \frac{1.30}{R_T R_C} \quad (1)$$

where

- R_T is in $k\Omega$
- C_T is in μF
- f is in kHz

Practical values of C_T fall between $0.001 \mu F$ and $0.1 \mu F$. Practical values of R_T fall between $1.8 k\Omega$ and $100 k\Omega$. This results in a frequency range typically from 130 Hz to 722 kHz.

10.2.1.2.2 Voltage Reference

The 5-V internal reference can be employed by use of an external resistor divider network to establish a reference common-mode voltage range (1.8 V to 3.4 V) within the error amplifiers (see [Figure 10-5](#)), or an external reference can be applied directly to the error amplifier. For operation from a fixed 5-V supply, the internal reference can be bypassed by applying the input voltage to both the V_{CC} and V_{REF} terminals. In this configuration, however, the input voltage is limited to a maximum of 6 V.

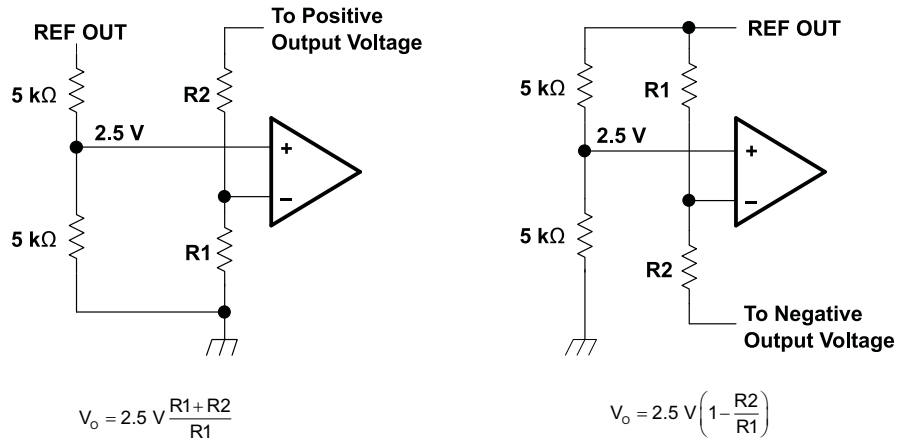

Figure 10-5. Error-Amplifier Bias Circuits

10.2.1.3 Application Curves

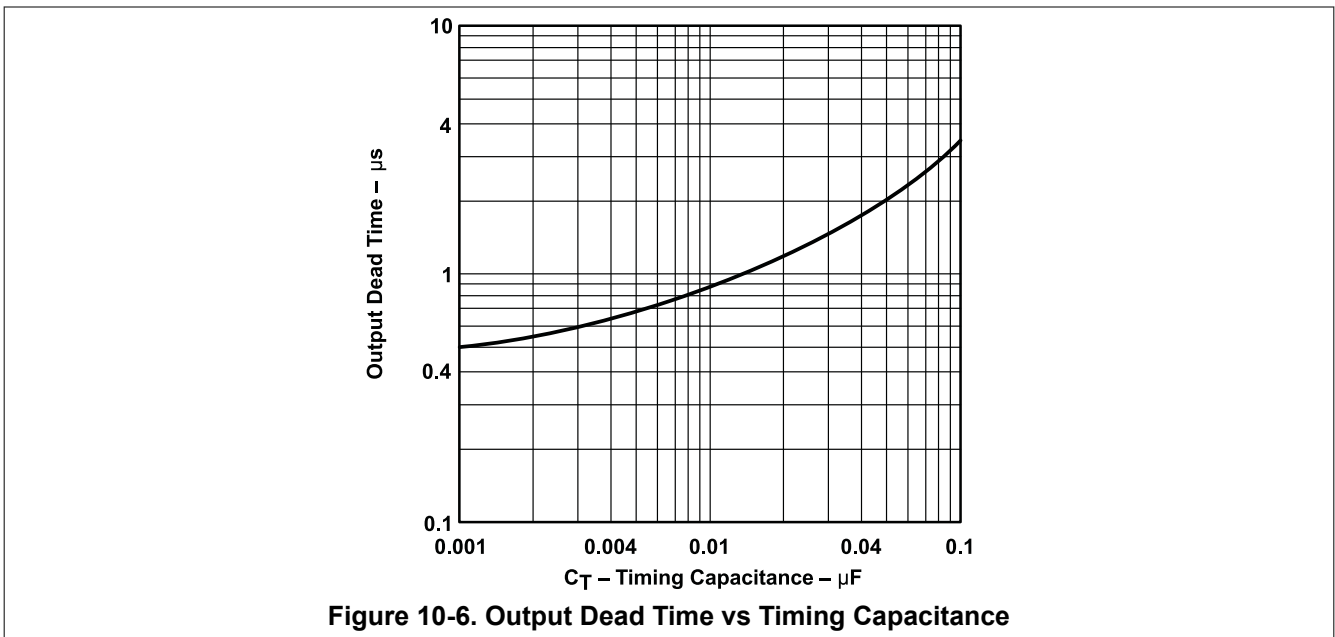

Figure 10-6. Output Dead Time vs Timing Capacitance

10.3 Examples of Other Output Stages

10.3.1 Flyback Converter

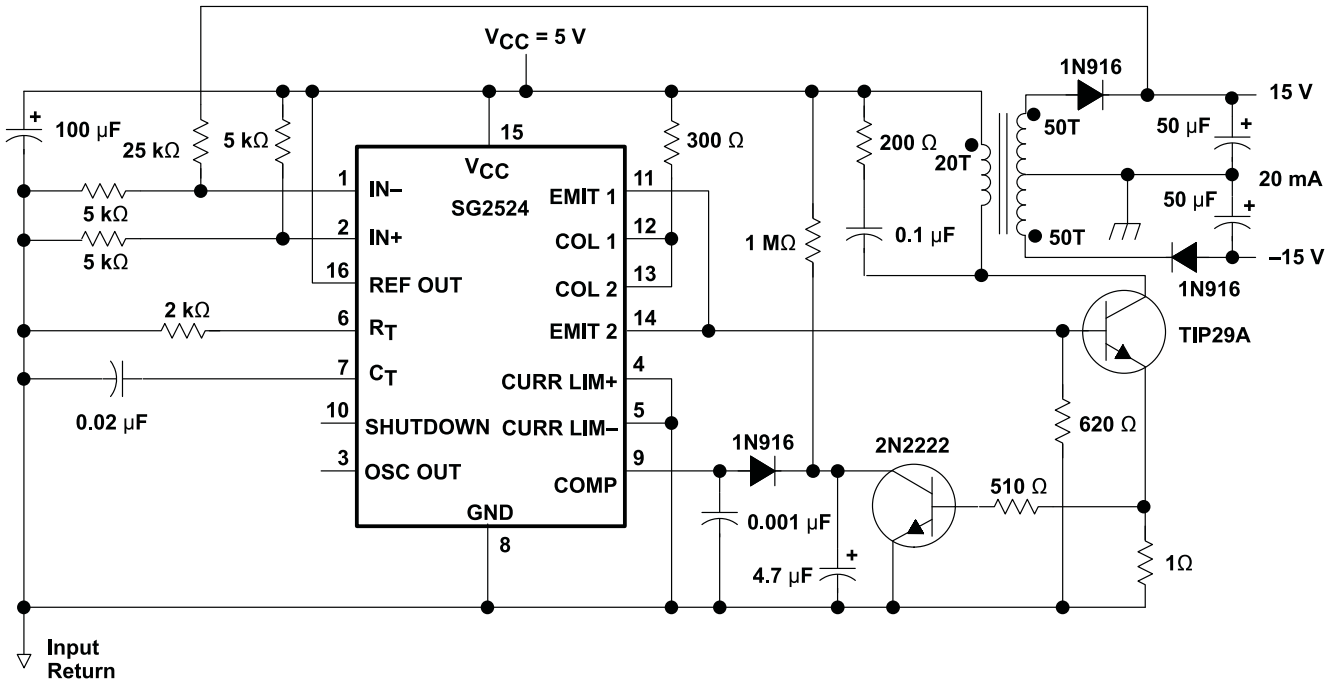

Figure 10-7. Flyback Converter Circuit Schematic

10.3.2 Single-Ended LC

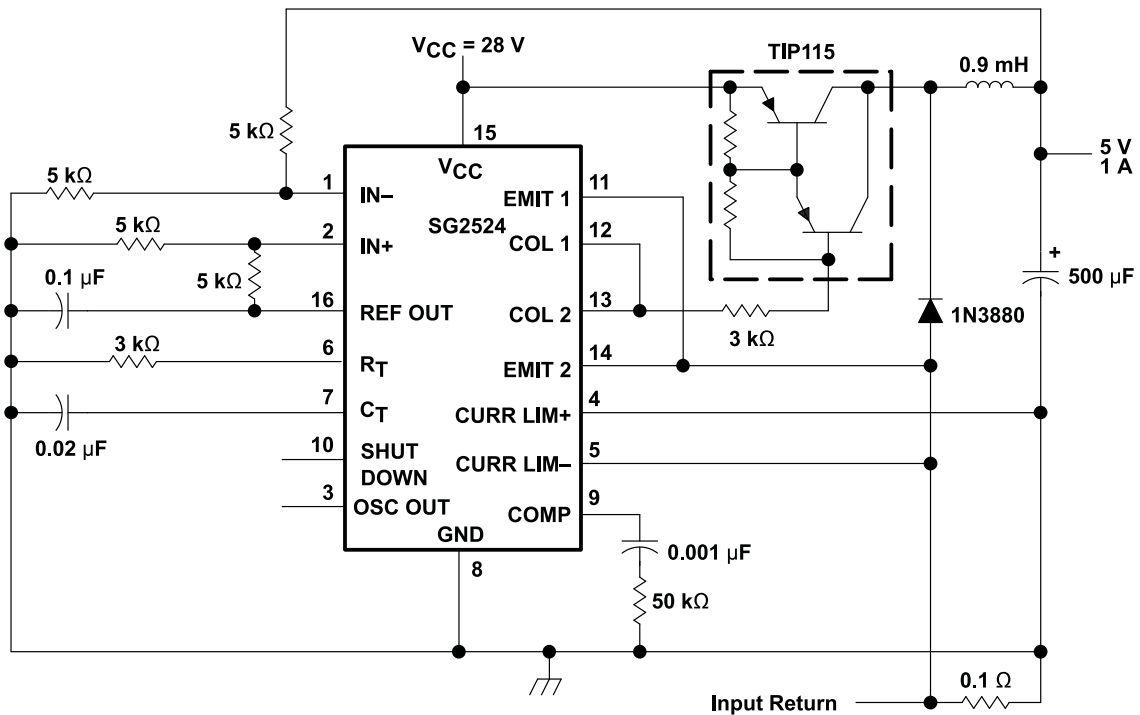

Figure 10-8. Single-Ended LC Circuit Schematic

10.3.3 Push-Pull Transformer-Coupled

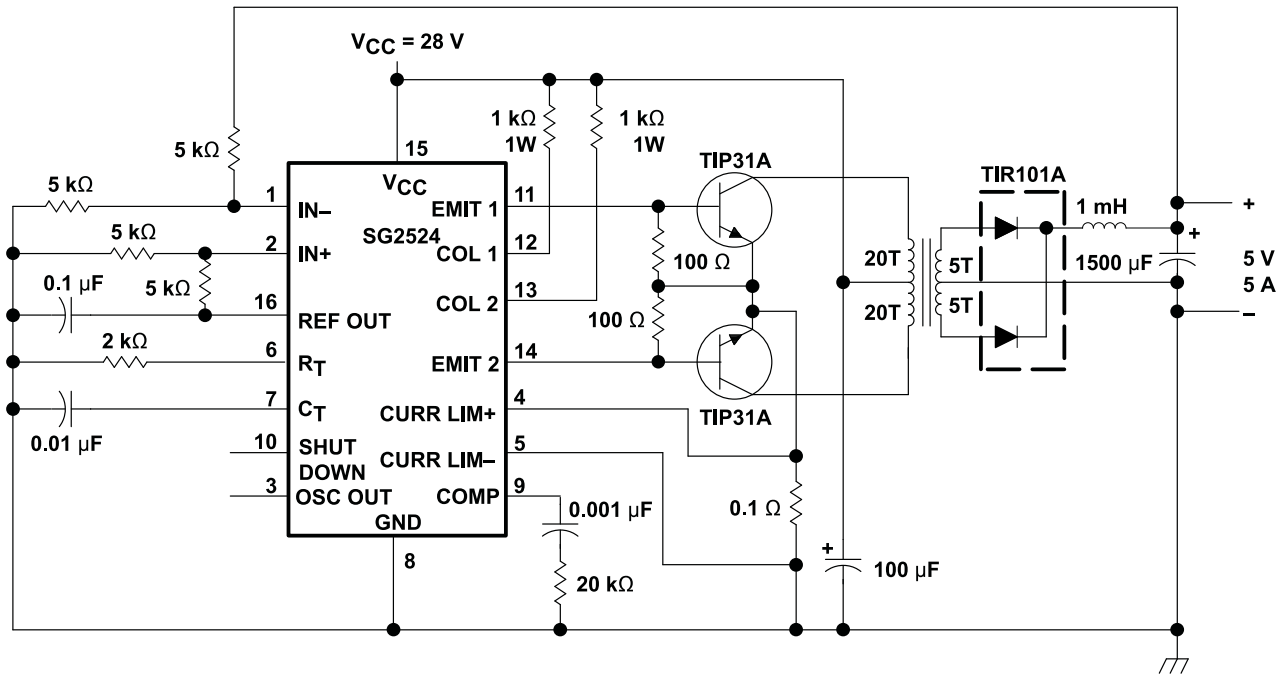

Figure 10-9. Push-Pull Transformer-Coupled Circuit Schematic

Power Supply Recommendations

SGx524 is designed to operate from an input voltage supply range between 8 V and 40 V. This input supply should be well regulated. If the input supply is located more than a few inches from the device, additional bulk capacitance may be required in addition to the ceramic bypass capacitors. A tantalum capacitor with a value of 47 μF is a typical choice, however this may vary depending upon the output power being delivered.

10 Layout

10.1 Layout Guidelines

Always try to use a low EMI inductor with a ferrite type closed core. Some examples would be toroid and encased E core inductors. Open core can be used if they have low EMI characteristics and are located a bit more away from the low power traces and components. Make the poles perpendicular to the PCB as well if using an open core. Stick cores usually emit the most unwanted noise.

10.1.1 Feedback Traces

Try to run the feedback trace as far from the inductor and noisy power traces as possible. You would also like the feedback trace to be as direct as possible and somewhat thick. These two sometimes involve a trade-off, but keeping it away from inductor EMI and other noise sources is the more critical of the two. Run the feedback trace on the side of the PCB opposite of the inductor with a ground plane separating the two.

10.1.2 Input/Output Capacitors

When using a low value ceramic input filter capacitor, it should be located as close to the VIN pin of the IC as possible. This will eliminate as much trace inductance effects as possible and give the internal IC rail a cleaner voltage supply. Some designs require the use of a feed-forward capacitor connected from the output to the feedback pin as well, usually for stability reasons. In this case it should also be positioned as close to the IC as possible. Using surface mount capacitors also reduces lead length and lessens the chance of noise coupling into the effective antenna created by through-hole components.

10.1.3 Compensation Components

External compensation components for stability should also be placed close to the IC. Surface mount components are recommended here as well for the same reasons discussed for the filter capacitors. These should not be located very close to the inductor either.

10.1.4 Traces and Ground Planes

Make all of the power (high-current) traces as short, direct, and thick as possible. It is good practice on a standard PCB board to make the traces an absolute minimum of 15 mils (0.381 mm) per ampere. The inductor, output capacitors, and output diode should be as close to each other possible. This helps reduce the EMI radiated by the power traces due to the high switching currents through them. This will also reduce lead inductance and resistance as well, which in turn reduces noise spikes, ringing, and resistive losses that produce voltage errors.

The grounds of the IC, input capacitors, output capacitors, and output diode (if applicable) should be connected close together directly to a ground plane. It would also be a good idea to have a ground plane on both sides of the PCB. This will reduce noise as well by reducing ground loop errors as well as by absorbing more of the EMI radiated by the inductor. For multi-layer boards with more than two layers, a ground plane can be used to separate the power plane (where the power traces and components are) and the signal plane (where the feedback and compensation and components are) for improved performance. On multi-layer boards the use of vias will be required to connect traces and different planes. It is good practice to use one standard via per 200 mA of current if the trace will need to conduct a significant amount of current from one plane to the other.

Arrange the components so that the switching current loops curl in the same direction. Due to the way switching regulators operate, there are two power states. One state when the switch is on and one when the switch is off. During each state there will be a current loop made by the power components that are currently conducting. Place the power components so that during each of the two states the current loop is conducting in the same direction. This prevents magnetic field reversal caused by the traces between the two half-cycles and reduces radiated EMI.

10.2 Layout Example

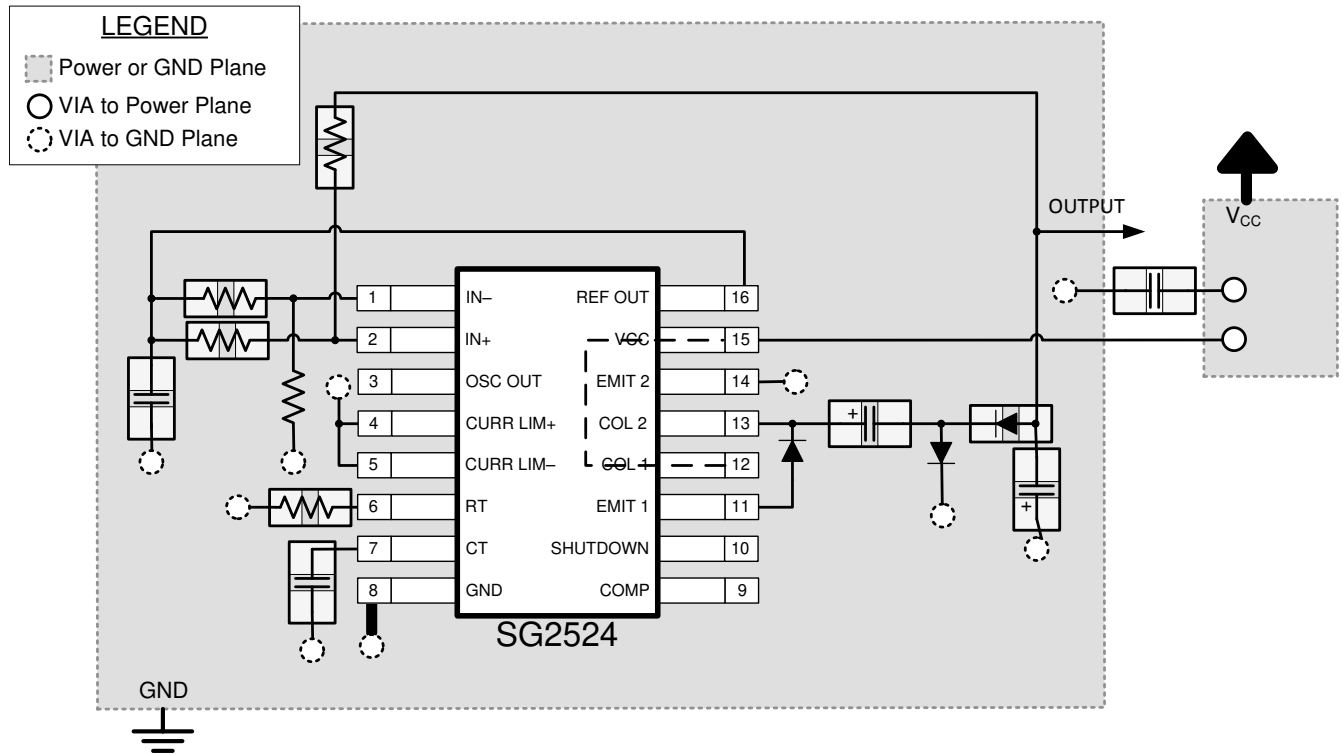

Figure 10-1. Layout Example for SG2524

11 Device and Documentation Support

11.1 Related Links

The table below lists quick access links. Categories include technical documents, support and community resources, tools and software, and quick access to sample or buy.

Table 11-1. Related Links

PARTS	PRODUCT FOLDER	SAMPLE & BUY	TECHNICAL DOCUMENTS	TOOLS & SOFTWARE	SUPPORT & COMMUNITY
SG2524	Click here	Click here	Click here	Click here	Click here
SG3524	Click here	Click here	Click here	Click here	Click here

11.2 Trademarks

All trademarks are the property of their respective owners.

Mechanical, Packaging, and Orderable Information

The following pages include mechanical, packaging, and orderable information. This information is the most current data available for the designated devices. This data is subject to change without notice and revision of this document. For browser-based versions of this data sheet, refer to the left-hand navigation.

PACKAGING INFORMATION

Orderable Device	Status (1)	Package Type	Package Drawing	Pins	Package Qty	Eco Plan (2)	Lead finish/ Ball material (6)	MSL Peak Temp (3)	Op Temp (°C)	Device Marking (4/5)	Samples
SG2524D	ACTIVE	SOIC	D	16	40	RoHS & Green	NIPDAU	Level-1-260C-UNLIM	-25 to 85	SG2524	Samples
SG2524DR	ACTIVE	SOIC	D	16	2500	RoHS & Green	NIPDAU	Level-1-260C-UNLIM	-25 to 85	SG2524	Samples
SG2524DRE4	ACTIVE	SOIC	D	16	2500	RoHS & Green	NIPDAU	Level-1-260C-UNLIM	-25 to 85	SG2524	Samples
SG2524DRG4	ACTIVE	SOIC	D	16	2500	RoHS & Green	NIPDAU	Level-1-260C-UNLIM	-25 to 85	SG2524	Samples
SG2524N	ACTIVE	PDIP	N	16	25	RoHS & Green	NIPDAU	N / A for Pkg Type	-25 to 85	SG2524N	Samples
SG3524D	LIFEBUY	SOIC	D	16	40	RoHS & Green	NIPDAU	Level-1-260C-UNLIM	0 to 70	SG3524	
SG3524DR	ACTIVE	SOIC	D	16	2500	RoHS & Green	NIPDAU	Level-1-260C-UNLIM	0 to 70	SG3524	Samples
SG3524DRE4	ACTIVE	SOIC	D	16	2500	RoHS & Green	NIPDAU	Level-1-260C-UNLIM	0 to 70	SG3524	Samples
SG3524N	ACTIVE	PDIP	N	16	25	RoHS & Green	NIPDAU	N / A for Pkg Type	0 to 70	SG3524N	Samples
SG3524NE4	ACTIVE	PDIP	N	16	25	RoHS & Green	NIPDAU	N / A for Pkg Type	0 to 70	SG3524N	Samples
SG3524NSR	ACTIVE	SO	NS	16	2000	RoHS & Green	NIPDAU	Level-1-260C-UNLIM	0 to 70	SG3524	Samples

(1) The marketing status values are defined as follows:

ACTIVE: Product device recommended for new designs.

LIFEBUY: TI has announced that the device will be discontinued, and a lifetime-buy period is in effect.

NRND: Not recommended for new designs. Device is in production to support existing customers, but TI does not recommend using this part in a new design.

PREVIEW: Device has been announced but is not in production. Samples may or may not be available.

OBSOLETE: TI has discontinued the production of the device.

(2) **RoHS:** TI defines "RoHS" to mean semiconductor products that are compliant with the current EU RoHS requirements for all 10 RoHS substances, including the requirement that RoHS substance do not exceed 0.1% by weight in homogeneous materials. Where designed to be soldered at high temperatures, "RoHS" products are suitable for use in specified lead-free processes. TI may reference these types of products as "Pb-Free".

RoHS Exempt: TI defines "RoHS Exempt" to mean products that contain lead but are compliant with EU RoHS pursuant to a specific EU RoHS exemption.

Green: TI defines "Green" to mean the content of Chlorine (Cl) and Bromine (Br) based flame retardants meet JS709B low halogen requirements of <=1000ppm threshold. Antimony trioxide based flame retardants must also meet the <=1000ppm threshold requirement.

(3) MSL, Peak Temp. - The Moisture Sensitivity Level rating according to the JEDEC industry standard classifications, and peak solder temperature.

(4) There may be additional marking, which relates to the logo, the lot trace code information, or the environmental category on the device.

(5) Multiple Device Markings will be inside parentheses. Only one Device Marking contained in parentheses and separated by a "~" will appear on a device. If a line is indented then it is a continuation of the previous line and the two combined represent the entire Device Marking for that device.

(6) Lead finish/Ball material - Orderable Devices may have multiple material finish options. Finish options are separated by a vertical ruled line. Lead finish/Ball material values may wrap to two lines if the finish value exceeds the maximum column width.

Important Information and Disclaimer:The information provided on this page represents TI's knowledge and belief as of the date that it is provided. TI bases its knowledge and belief on information provided by third parties, and makes no representation or warranty as to the accuracy of such information. Efforts are underway to better integrate information from third parties. TI has taken and continues to take reasonable steps to provide representative and accurate information but may not have conducted destructive testing or chemical analysis on incoming materials and chemicals. TI and TI suppliers consider certain information to be proprietary, and thus CAS numbers and other limited information may not be available for release.

In no event shall TI's liability arising out of such information exceed the total purchase price of the TI part(s) at issue in this document sold by TI to Customer on an annual basis.

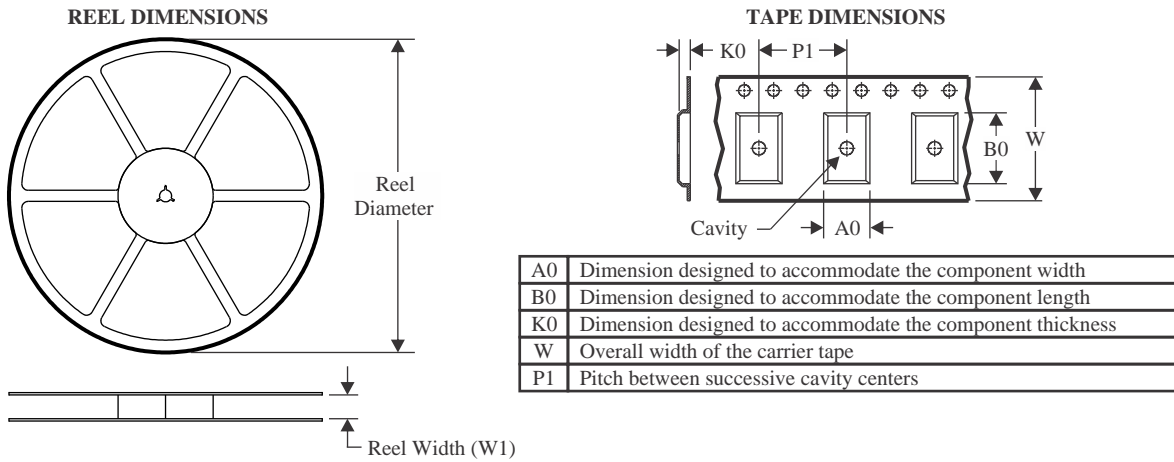
TAPE AND REEL INFORMATION

QUADRANT ASSIGNMENTS FOR PIN 1 ORIENTATION IN TAPE



*All dimensions are nominal

Device	Package Type	Package Drawing	Pins	SPQ	Reel Diameter (mm)	Reel Width W1 (mm)	A0 (mm)	B0 (mm)	K0 (mm)	P1 (mm)	W (mm)	Pin1 Quadrant
SG2524DR	SOIC	D	16	2500	330.0	16.4	6.5	10.3	2.1	8.0	16.0	Q1
SG2524DRG4	SOIC	D	16	2500	330.0	16.4	6.5	10.3	2.1	8.0	16.0	Q1
SG3524DR	SOIC	D	16	2500	330.0	16.4	6.5	10.3	2.1	8.0	16.0	Q1
SG3524NSR	SO	NS	16	2000	330.0	16.4	8.2	10.5	2.5	12.0	16.0	Q1

TAPE AND REEL BOX DIMENSIONS

*All dimensions are nominal

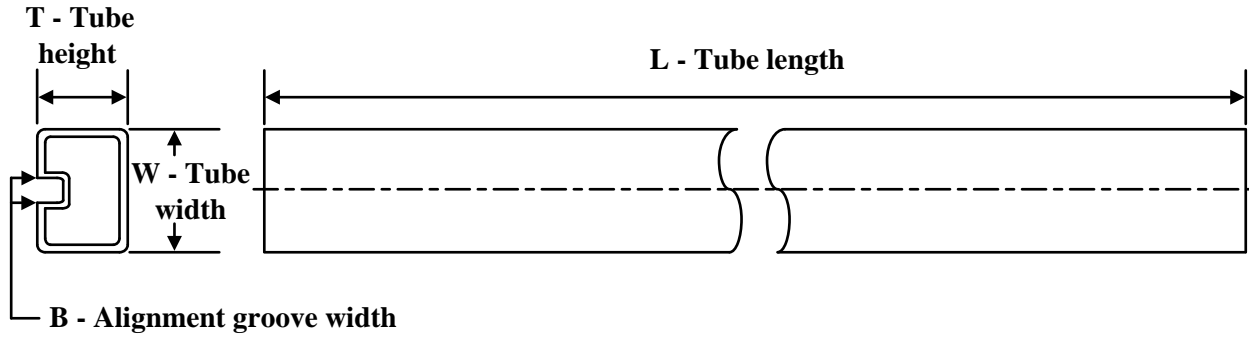
Device	Package Type	Package Drawing	Pins	SPQ	Length (mm)	Width (mm)	Height (mm)
SG2524DR	SOIC	D	16	2500	340.5	336.1	32.0
SG2524DRG4	SOIC	D	16	2500	340.5	336.1	32.0
SG3524DR	SOIC	D	16	2500	340.5	336.1	32.0
SG3524NSR	SO	NS	16	2000	356.0	356.0	35.0

TUBE

*All dimensions are nominal

Device	Package Name	Package Type	Pins	SPQ	L (mm)	W (mm)	T (μm)	B (mm)
SG2524D	D	SOIC	16	40	507	8	3940	4.32
SG2524N	N	PDIP	16	25	506	13.97	11230	4.32
SG3524D	D	SOIC	16	40	507	8	3940	4.32
SG3524N	N	PDIP	16	25	506	13.97	11230	4.32
SG3524NE4	N	PDIP	16	25	506	13.97	11230	4.32



PACKAGE OUTLINE

NS0016A

SOP - 2.00 mm max height

SOP



4220735/A 12/2021

NOTES:

1. All linear dimensions are in millimeters. Dimensions in parenthesis are for reference only. Dimensioning and tolerancing per ASME Y14.5M.
2. This drawing is subject to change without notice.
3. This dimension does not include mold flash, protrusions, or gate burrs. Mold flash, protrusions, or gate burrs shall not exceed 0.15 mm, per side.
4. This dimension does not include interlead flash. Interlead flash shall not exceed 0.25 mm, per side.

EXAMPLE BOARD LAYOUT

NS0016A

SOP - 2.00 mm max height

SOP



SOLDER MASK DETAILS

4220735/A 12/2021

NOTES: (continued)

5. Publication IPC-7351 may have alternate designs.

6. Solder mask tolerances between and around signal pads can vary based on board fabrication site.

EXAMPLE STENCIL DESIGN

NS0016A

SOP - 2.00 mm max height

SOP



SOLDER PASTE EXAMPLE
BASED ON 0.125 mm THICK STENCIL
SCALE:7X

4220735/A 12/2021

NOTES: (continued)

7. Laser cutting apertures with trapezoidal walls and rounded corners may offer better paste release. IPC-7525 may have alternate design recommendations.
8. Board assembly site may have different recommendations for stencil design.

D (R-PDSO-G16)

PLASTIC SMALL OUTLINE



- NOTES:
- A. All linear dimensions are in inches (millimeters).
 - B. This drawing is subject to change without notice.
 - C. Body length does not include mold flash, protrusions, or gate burrs. Mold flash, protrusions, or gate burrs shall not exceed 0.006 (0,15) each side.
 - D. Body width does not include interlead flash. Interlead flash shall not exceed 0.017 (0,43) each side.
 - E. Reference JEDEC MS-012 variation AC.

D (R-PDSO-G16)

PLASTIC SMALL OUTLINE



- NOTES:
- A. All linear dimensions are in millimeters.
 - B. This drawing is subject to change without notice.
 - C. Publication IPC-7351 is recommended for alternate designs.
 - D. Laser cutting apertures with trapezoidal walls and also rounding corners will offer better paste release. Customers should contact their board assembly site for stencil design recommendations. Refer to IPC-7525 for other stencil recommendations.
 - E. Customers should contact their board fabrication site for solder mask tolerances between and around signal pads.

MECHANICAL DATA

NS (R-PDSO-G**)

PLASTIC SMALL-OUTLINE PACKAGE

14-PINS SHOWN



- NOTES:
- A. All linear dimensions are in millimeters.
 - B. This drawing is subject to change without notice.
 - C. Body dimensions do not include mold flash or protrusion, not to exceed 0,15.

N (R-PDIP-T**)

PLASTIC DUAL-IN-LINE PACKAGE

16 PINS SHOWN



4040049/E 12/2002

- NOTES:
- A. All linear dimensions are in inches (millimeters).
 - B. This drawing is subject to change without notice.
 - $\triangle C$ Falls within JEDEC MS-001, except 18 and 20 pin minimum body length (Dim A).
 - $\triangle D$ The 20 pin end lead shoulder width is a vendor option, either half or full width.

IMPORTANT NOTICE AND DISCLAIMER

TI PROVIDES TECHNICAL AND RELIABILITY DATA (INCLUDING DATA SHEETS), DESIGN RESOURCES (INCLUDING REFERENCE DESIGNS), APPLICATION OR OTHER DESIGN ADVICE, WEB TOOLS, SAFETY INFORMATION, AND OTHER RESOURCES "AS IS" AND WITH ALL FAULTS, AND DISCLAIMS ALL WARRANTIES, EXPRESS AND IMPLIED, INCLUDING WITHOUT LIMITATION ANY IMPLIED WARRANTIES OF MERCHANTABILITY, FITNESS FOR A PARTICULAR PURPOSE OR NON-INFRINGEMENT OF THIRD PARTY INTELLECTUAL PROPERTY RIGHTS.

These resources are intended for skilled developers designing with TI products. You are solely responsible for (1) selecting the appropriate TI products for your application, (2) designing, validating and testing your application, and (3) ensuring your application meets applicable standards, and any other safety, security, regulatory or other requirements.

These resources are subject to change without notice. TI grants you permission to use these resources only for development of an application that uses the TI products described in the resource. Other reproduction and display of these resources is prohibited. No license is granted to any other TI intellectual property right or to any third party intellectual property right. TI disclaims responsibility for, and you will fully indemnify TI and its representatives against, any claims, damages, costs, losses, and liabilities arising out of your use of these resources.

TI's products are provided subject to [TI's Terms of Sale](#) or other applicable terms available either on [ti.com](https://www.ti.com) or provided in conjunction with such TI products. TI's provision of these resources does not expand or otherwise alter TI's applicable warranties or warranty disclaimers for TI products.

TI objects to and rejects any additional or different terms you may have proposed.

Mailing Address: Texas Instruments, Post Office Box 655303, Dallas, Texas 75265
Copyright © 2024, Texas Instruments Incorporated

Looking for pricing, stock, or lifecycle information?

Click below to explore more details on WIN SOURCE:

 [View SG3524DR](#) on WIN SOURCE

 [Texas Instruments](#) Information

Optimize Your Supply Chain with WIN SOURCE Solutions

-  Global Sourcing Solution
-  Obsolete Management
-  Cost Control Management
-  Shortage Management
-  Alternative Solution
-  Excess Inventory Management