



**THE DATASHEET OF
SI3402-A-GMR**





**Si3402-A-GM to Si3402-B-GM EVB Modifications
Version 0.4**

The Si3402-B-GM device requires component value changes from those used with the Si3402-A-GM evaluation board (EVB) reference design. Table 1 below is a summary of the required modifications.

Following Table 1 are two reference schematic excerpts showing the locations of the modified component values for both the isolated (flyback) and non-isolated (buck) topologies.

Table 1. Si3402-B-GM EVB modifications versus the Si3402-A-GM EVB

Item	Modification description	Application design effect
M1	Detect resistor value change	The former 25.5kΩ detect resistor must be replaced by 24.3kΩ 1%
M2	Classification resistor value change	The following 1% resistors must be used: Class0: 681.00 or higher (It is optional to place this resistor) Class1: 140.0 Class2: 75.0 Class3: 48.7 Class4: 33.2
M3*	ISO EVB DCDC 3.3V changes Flyback	C8, R9 & C23 are not need—Do not populate them. C9=10nF, C21=33nF, R12=475 Ω & R8=1.1k Ω Replace D2 (DFLT15A) with DFLT30A * See Revision Notes
M4	ISO EVB DCDC 5V changes Flyback	C8, R9 & C23 are not need—Do not populate them. C9=3.3nF, C21=15nF, R12=0 & R8=0 (place zero Ω resistors) Replace D2 (DFLT15A) with DFLT30A
M5	ISO EVB DCDC 12V changes Flyback	C8, R9 & C23 are not need—Do not populate them. C9=10nF, C21=15nF, R12=0, R8=0 (place zero Ω resistor) R7=3k Replace D2 (DFLT15A) with DFLT30A
M6	DCDC reference voltage change (Buck case only)	Now 1.35V instead of previous 1.23V. Thus, R5 changes from 2.87kΩ 1% to 3.24kΩ 1%. R6 (1%) is modified according to this table:

		Vout Target	R5 kΩ	R6 kΩ	Vref	Vout Measured
		3.3	3.24	4.64	1.35	3.37
		5	3.24	8.66	1.35	4.96
		9	3.24	18.2	1.35	8.93
		12	3.24	25.5	1.35	11.98
M7	BUCK EVB DCDC 3.3V compensation network changes	C19, C20 & C9 are not need—Do not populate them. R8 can be populated with a 0Ω resistor (creating a short between pins 3 and 4) or left unpopulated, since the ISOSSFT function is now internal (see datasheet). C7=1nF, R7=47kΩ ±20%.				
M8	BUCK EVB DCDC 5V compensation network changes	C19, C20, R8 & C9 are not need—Do not populate them. R8 can be populated with a 0Ω resistor (creating a short between pins 3 and 4) or left unpopulated, since the ISOSSFT function is now internal (see datasheet). C7=1nF, R7=47kΩ ±20%.				
M9	BUCK EVB DCDC 12V compensation network changes	C19, C20, R8 & C9 are not need—Do not populate them. R8 can be populated with a 0Ω resistor (creating a short between pins 3 and 4) or left unpopulated, since the ISOSSFT function is now internal (see datasheet). C7=1nF, R7=47kΩ ±20%.				

Si3402ISO (Flyback, Isolated) EVB Reference Design – 5V

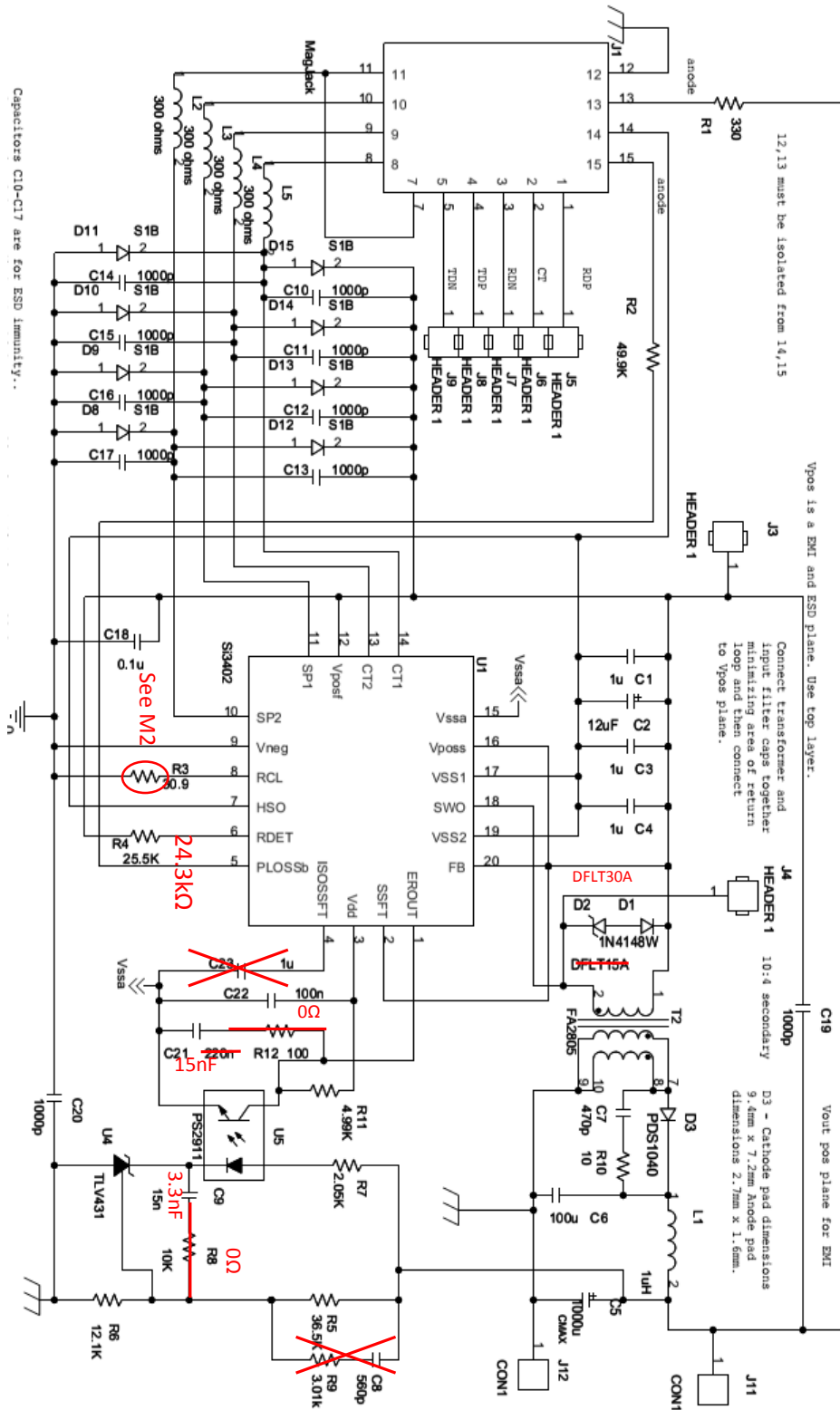

Si3402 (Buck, Non-Isolated) EVB Reference Design - 5V

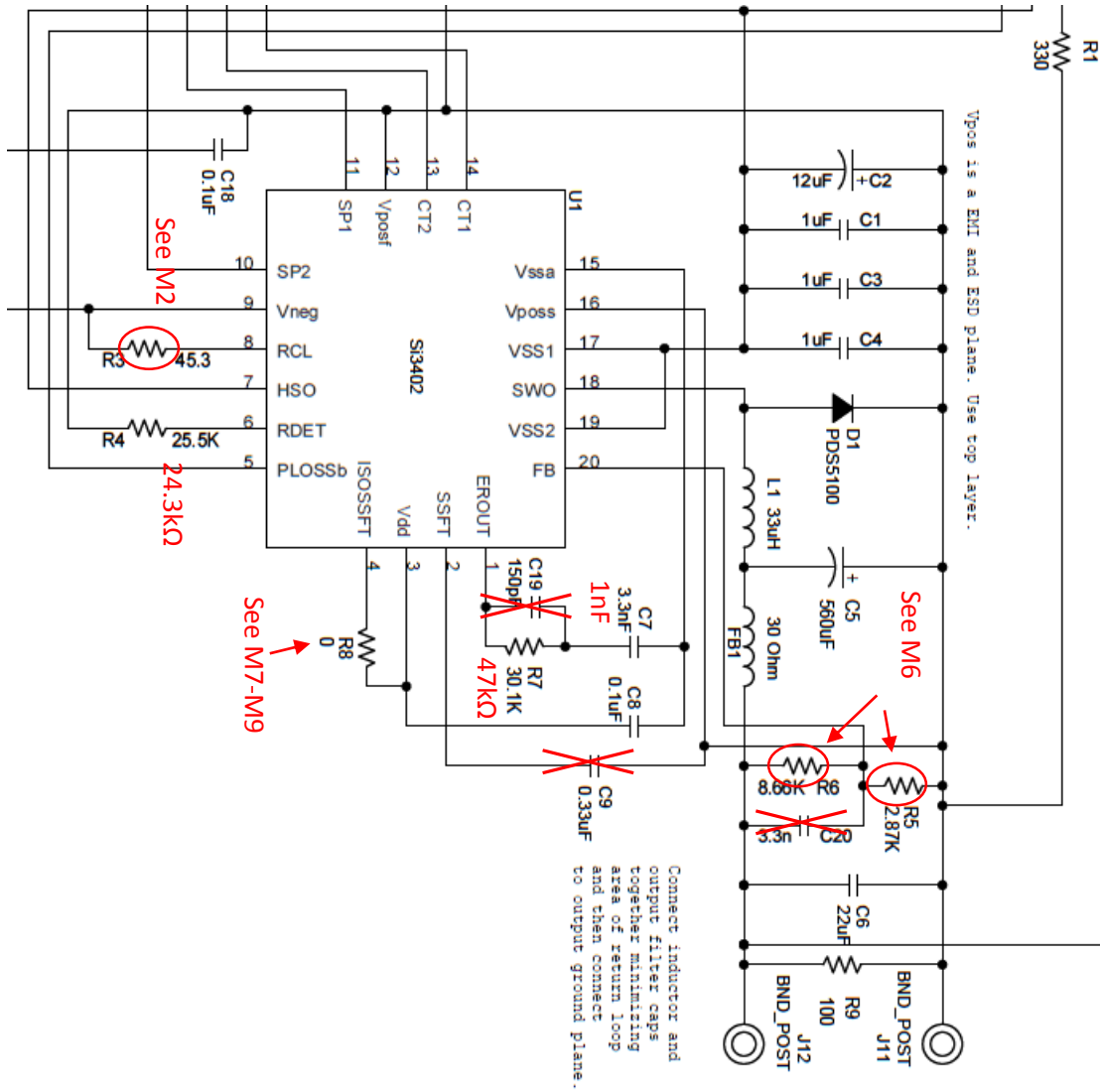



Revision Notes

26 August 2015:

- Added B5 indicating the Si3402-B-EN1 samples should be run only at room temperature
- Clarified Buck (Non-Isolated) case R7 to standard value 47k Ω and relaxed to 20% tolerance

28 October 2015:

- Previous version silicon errata resolved
- Several components in the change list updated
- Document renamed “**Si3402-B RevA3 Change List_<YYYYMMDD>**”

24 November 2015:

- M2 and M6 components updated
- Aligns with production Si3402-B-GM silicon

08 December 2015: (Version 0.3)

- Changed title of doc and name of file
- Clarified M7-M9 changes with regard to R8

21 March 2016: (Version 0.4)

- Updated M3, the 3.3V Isolated Flyback case.
 - Explanation: 3.3V Flyback compensation was updated to address a small overshoot condition under no-load conditions (3.66V is allowed, the overshoot was 3.73V). The problem is fixed with revised compensation with a resulting overshoot of about 3.5V.
 - If a no-load condition is unlikely, the customer may keep the original M3 change recommendation:
 - C8, R9 & C23 are not need—Do not populate them
 - C9=3.3nF, C21=15nF, R12=0 & R8=0 (place zero Ω resistors)
 - Replace D2 (DFLT15A) with DFLT30A

Looking for pricing, stock, or lifecycle information?

Click below to explore more details on WIN SOURCE:

 [View SI3402-A-GMR on WIN SOURCE](#)

 [Silicon Labs](#) Information

Optimize Your Supply Chain with WIN SOURCE Solutions

-  Global Sourcing Solution
-  Obsolete Management
-  Cost Control Management
-  Shortage Management
-  Alternative Solution
-  Excess Inventory Management