



**THE DATASHEET OF  
74ALVC245MTC**



# 74ALVC245

## Low Voltage Bidirectional Transceiver with 3.6V Tolerant Inputs and Outputs

### Features

- 1.65V to 3.6V  $V_{CC}$  supply operation
- 3.6V tolerant inputs and outputs
- Power-off high impedance inputs and outputs
- Supports Live Insertion and Withdrawal<sup>(1)</sup>
- $t_{PD}$ :
  - 3.4ns max. for 3.0V to 3.6V  $V_{CC}$
  - 3.9ns max. for 2.3V to 2.7V  $V_{CC}$
  - 6ns max. for 1.65V to 1.95V  $V_{CC}$
- Uses patented Quiet Series™ noise/EMI reduction circuitry
- Latchup conforms to JEDEC JED78
- ESD performance:
  - Human body model > 2000V
  - Machine model > 200V

### Note:

1. To ensure the high impedance state during power up and power down,  $\overline{OE}_n$  should be tied to  $V_{CC}$  through a pull up resistor. The minimum value of the resistor is determined by the current sourcing capability of the driver.

### General Description

The ALVC245 contains eight non-inverting bidirectional buffers with 3-STATE outputs and is intended for bus oriented applications. The  $\overline{T/R}$  input determines the direction of data flow. The  $\overline{OE}$  input disables both the A and B ports by placing them in a high impedance state.

The 74ALVC245 is designed for low voltage (1.65V to 3.6V)  $V_{CC}$  applications with I/O compatibility up to 3.6V.

The 74ALVC245 is fabricated with an advanced CMOS technology to achieve high-speed operation while maintaining low CMOS power dissipation.

### Ordering Information

Order Number	Package Number	Package Description
74ALVC245WM	M20B	20-Lead Small Outline Integrated Circuit (SOIC), JEDEC MS-013, 0.300" Wide
74ALVC245MTC	MTC20	20-Lead Thin Shrink Small Outline Package (TSSOP), JEDEC MO-153, 4.4mm Wide

Device also available in Tape and Reel. Specify by appending suffix letter "X" to the ordering number.

 All packages are lead free per JEDEC: J-STD-020B standard.

### Connection Diagram

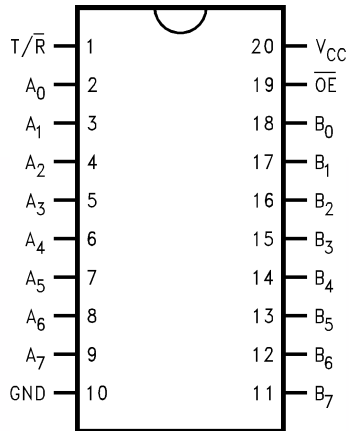

### Logic Symbol

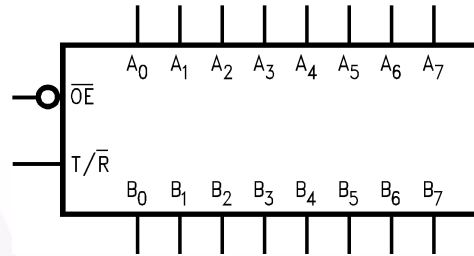

### Pin Description

Pin Names	Description
$\overline{OE}$	Output Enable Input (Active LOW)
$T/\overline{R}$	Transmit/Receive Input
$A_0-A_7$	Side A Inputs or 3-STATE Outputs
$B_0-B_7$	Side B Inputs or 3-STATE Outputs

### Truth Table

Inputs		Outputs
$\overline{OE}$	$T/\overline{R}$	
L	L	Bus $B_0-B_7$ Data to Bus $A_0-A_7$
L	H	Bus $A_0-A_7$ Data to Bus $B_0-B_7$
H	X	HIGH Z State on $A_0-A_7, B_0-B_7$ <sup>(2)</sup>

H = HIGH Voltage Level

L = LOW Voltage Level

X = Immaterial

Z = High Impedance

#### Note:

- Unused bus terminals during HIGH Z State must be held HIGH or LOW.

### Logic Diagram

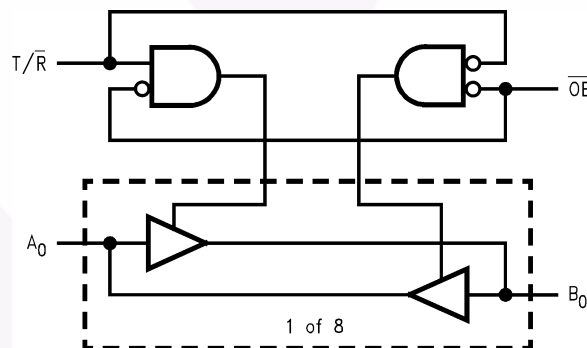

## Absolute Maximum Ratings

Stresses exceeding the absolute maximum ratings may damage the device. The device may not function or be operable above the recommended operating conditions and stressing the parts to these levels is not recommended. In addition, extended exposure to stresses above the recommended operating conditions may affect device reliability. The absolute maximum ratings are stress ratings only.

Symbol	Parameter	Rating
$V_{CC}$	Supply Voltage	-0.5V to +4.6V
$V_I$	DC Input Voltage	-0.5V to 4.6V
$V_O$	Output Voltage <sup>(3)</sup>	-0.5V to $V_{CC}$ +0.5V
$I_{IK}$	DC Input Diode Current, $V_I < 0V$	-50mA
$I_{OK}$	DC Output Diode Current, $V_O < 0V$	-50mA
$I_{OH}/I_{OL}$	DC Output Source/Sink Current	$\pm 50mA$
$I_{CC}$ or GND	DC $V_{CC}$ or GND Current per Supply Pin	$\pm 100mA$
$T_{STG}$	Storage Temperature Range	-65°C to +150°C

**Note:**

3.  $I_O$  Absolute Maximum Rating must be observed, limited to 4.6V.

## Recommended Operating Conditions<sup>(4)</sup>

The Recommended Operating Conditions table defines the conditions for actual device operation. Recommended operating conditions are specified to ensure optimal performance to the datasheet specifications. Fairchild does not recommend exceeding them or designing to absolute maximum ratings.

Symbol	Parameter	Rating
$V_{CC}$	Supply Voltage	1.65V to 3.6V
$V_I$	Input Voltage	0V to $V_{CC}$
$V_O$	Output Voltage	0V to $V_{CC}$
$T_A$	Free Air Operating Temperature	-40°C to +85°C
$\Delta V / \Delta t$	Minimum Input Edge Rate: $V_{IN} = 0.8V$ to $2.0V$ , $V_{CC} = 3.0V$	10ns/V

**Note:**

4. Floating or unused control inputs must be held HIGH or LOW.

## DC Electrical Characteristics

Symbol	Parameter	V <sub>CC</sub> (V)	Conditions	Min.	Max.	Units
V <sub>IH</sub>	HIGH Level Input Voltage	1.65–1.95		0.65 x V <sub>CC</sub>		V
		2.3–2.7		1.7		
		2.7–3.6		2.0		
V <sub>IL</sub>	LOW Level Input Voltage	1.65–1.95			0.35 x V <sub>CC</sub>	V
		2.3–2.7			0.7	
		2.7–3.6			0.8	
V <sub>OH</sub>	HIGH Level Output Voltage	1.65–3.6	I <sub>OH</sub> = –100μA	V <sub>CC</sub> – 0.2		V
		1.65	I <sub>OH</sub> = –4mA	1.2		
		2.3	I <sub>OH</sub> = –6mA	2.0		
		2.3	I <sub>OH</sub> = –12mA	1.7		
		2.7		2.2		
		3.0		2.4		
		3.0	I <sub>OH</sub> = –24mA	2		
V <sub>OL</sub>	LOW Level Output Voltage	1.65–3.6	I <sub>OL</sub> = 100μA		0.2	V
		1.65	I <sub>OL</sub> = 4mA		0.45	
		2.3	I <sub>OL</sub> = mA		0.4	
		2.3	I <sub>OL</sub> = 12mA		0.7	
		2.7			0.4	
		3.0	I <sub>OL</sub> = 24mA		0.55	
I <sub>I</sub>	Input Leakage Current	3.6	0 ≤ V <sub>I</sub> ≤ 3.6V		±5.0	μA
I <sub>OZ</sub>	3-STATE Output Leakage	3.6	0 ≤ V <sub>O</sub> ≤ 3.6V		±10	μA
I <sub>CC</sub>	Quiescent Supply Current	3.6	V <sub>I</sub> = V <sub>CC</sub> or GND, I <sub>O</sub> = 0		10	μA
ΔI <sub>CC</sub>	Increase in I <sub>CC</sub> per Input	3–3.6	V <sub>IH</sub> = V <sub>CC</sub> – 0.6V		750	μA

## AC Electrical Characteristics

Symbol	Parameter	T <sub>A</sub> = –40°C to +85°C, R <sub>L</sub> = 500Ω								Units
		C <sub>L</sub> = 50pF				C <sub>L</sub> = 30pF				
		V <sub>CC</sub> = 3.3V ± 0.3V		V <sub>CC</sub> = 2.7V		V <sub>CC</sub> = 2.5V ± 0.2V		V <sub>CC</sub> = 1.8V ± 0.15V		
		Min.	Max.	Min.	Max.	Min.	Max.	Min.	Max.	
t <sub>PHL</sub> , t <sub>PLH</sub>	Propagation Delay	1.3	3.4		3.9	1.0	3.5	1.5	6.0	ns
t <sub>PZL</sub> , t <sub>PZH</sub>	Output Enable Time	1.6	5.5		6.3	2.0	6.0	2.7	8.6	ns
t <sub>PLZ</sub> , t <sub>PHZ</sub>	Output Disable Time	1.7	5.5		5.3	0.8	4.8	1.5	8.0	ns

## Capacitance

Symbol	Parameter		Conditions	T <sub>A</sub> = +25°C		Units
				V <sub>CC</sub>	Typical	
C <sub>IN</sub>	Input Capacitance	Control	V <sub>I</sub> = 0V or V <sub>CC</sub>	3.3	3	pF
C <sub>I/O</sub>	Input/ Output Capacitance	A or B Ports	V <sub>I</sub> = 0V or V <sub>CC</sub>	3.3	6	
C <sub>PD</sub>	Power Dissipation Capacitance	Outputs Enabled	f = 10MHz, C <sub>L</sub> = 0pF	3.3	30	pF
				2.5	27	
				1.8	25	
		Outputs Disabled	f = 10MHz, C <sub>L</sub> = 0pF	3.3	0	
				2.5	0	
1.8	0					

## AC Loading and Waveforms

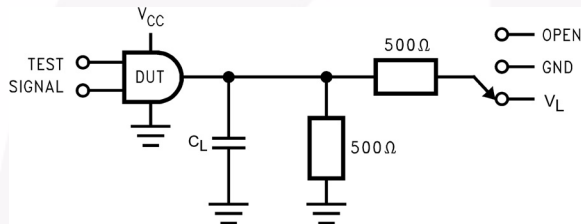

Figure 1. AC Test Circuit

Table 1. Values for Figure 1

Test	Switch
t <sub>PLH</sub> , t <sub>PHL</sub>	Open
t <sub>PZL</sub> , t <sub>PLZ</sub>	V <sub>L</sub>
t <sub>PZH</sub> , t <sub>PHZ</sub>	GND

Table 2. Variable Matrix

(Input Characteristics: f = 1MHz; t<sub>r</sub> = t<sub>f</sub> = 2ns; Z<sub>0</sub> = 50Ω)

Symbol	V <sub>CC</sub>			
	3.3V ± 0.3V	2.7V	2.5V ± 0.2V	1.8V ± 0.15V
V <sub>mi</sub>	1.5V	1.5V	V <sub>CC</sub> / 2	V <sub>CC</sub> / 2
V <sub>mo</sub>	1.5V	1.5V	V <sub>CC</sub> / 2	V <sub>CC</sub> / 2
V <sub>X</sub>	V <sub>OL</sub> + 0.3V	V <sub>OL</sub> + 0.3V	V <sub>OL</sub> + 0.15V	V <sub>OL</sub> + 0.15V
V <sub>Y</sub>	V <sub>OH</sub> - 0.3V	V <sub>OH</sub> - 0.3V	V <sub>OH</sub> - 0.15V	V <sub>OH</sub> - 0.15V
V <sub>L</sub>	6V	6V	V <sub>CC</sub> × 2	V <sub>CC</sub> × 2

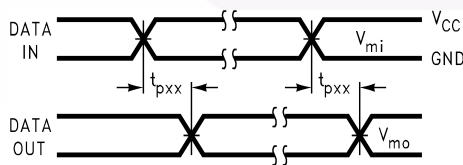

Figure 2. Waveform for Inverting and Non-Inverting Functions

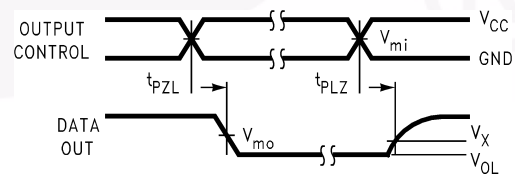
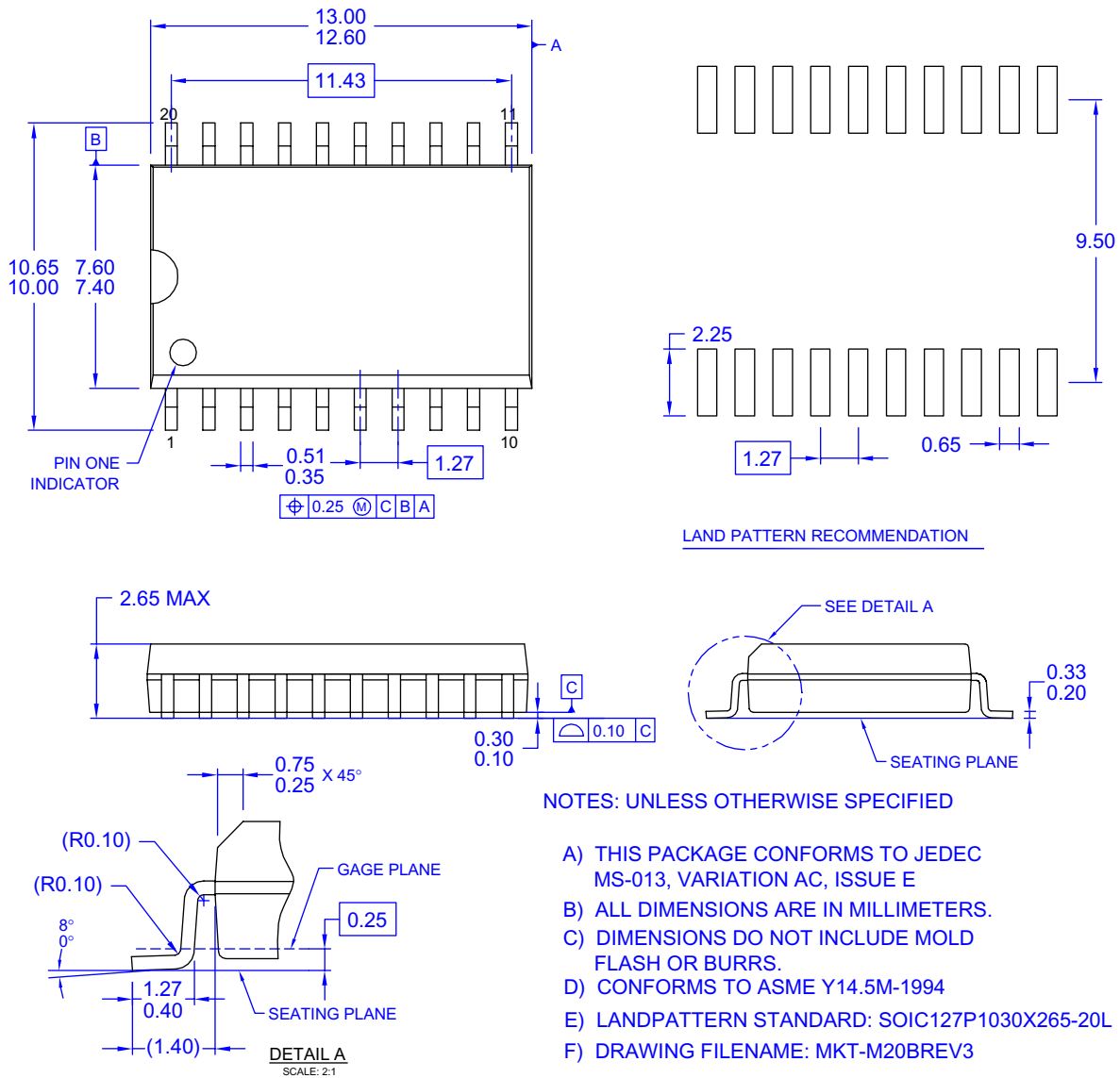

Figure 3. 3-STATE Output Low Enable and Disable Times for Low Voltage Logic

### Physical Dimensions



**Figure 4. 20-Lead Small Outline Integrated Circuit (SOIC), JEDEC MS-013, 0.300" Wide**

Package drawings are provided as a service to customers considering Fairchild components. Drawings may change in any manner without notice. Please note the revision and/or date on the drawing and contact a Fairchild Semiconductor representative to verify or obtain the most recent revision. Package specifications do not expand the terms of Fairchild's worldwide terms and conditions, specifically the warranty therein, which covers Fairchild products.

Always visit Fairchild Semiconductor's online packaging area for the most recent package drawings:

<http://www.fairchildsemi.com/packaging/>

Physical Dimensions (Continued)

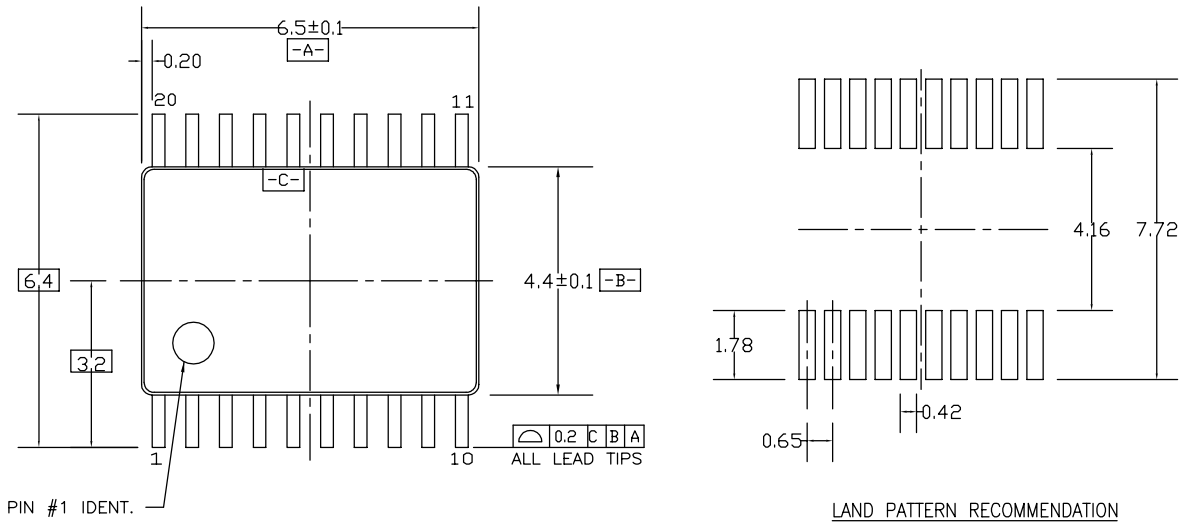

PIN #1 IDENT.

LAND PATTERN RECOMMENDATION

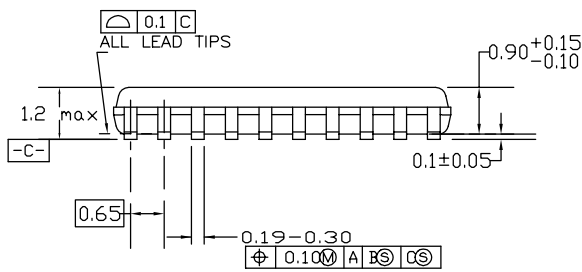

DIMENSIONS ARE IN MILLIMETERS

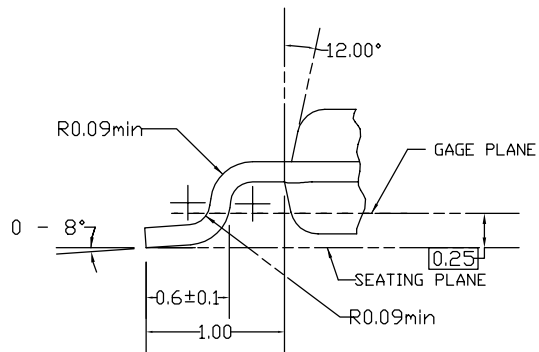
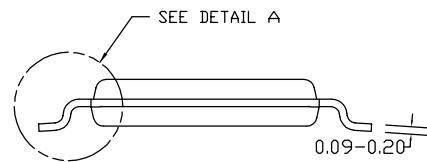

DETAIL A

NOTES:

- A. CONFORMS TO JEDEC REGISTRATION MD-153, VARIATION AC, REF NOTE 6, DATE 7/93.
- B. DIMENSIONS ARE IN MILLIMETERS.
- C. DIMENSIONS ARE EXCLUSIVE OF BURRS, MOLDS FLASH, AND TIE BAR EXTRUSIONS.
- D. DIMENSIONS AND TOLERANCES PER ANSI Y14.5M, 1982.

MTC20REV D1

Figure 5. 20-Lead Thin Shrink Small Outline Package (TSSOP), JEDEC MO-153, 4.4mm Wide

Package drawings are provided as a service to customers considering Fairchild components. Drawings may change in any manner without notice. Please note the revision and/or date on the drawing and contact a Fairchild Semiconductor representative to verify or obtain the most recent revision. Package specifications do not expand the terms of Fairchild's worldwide terms and conditions, specifically the warranty therein, which covers Fairchild products.



Always visit Fairchild Semiconductor's online packaging area for the most recent package drawings:

<http://www.fairchildsemi.com/packaging/>



**TRADEMARKS**

The following includes registered and unregistered trademarks and service marks, owned by Fairchild Semiconductor and/or its global subsidiaries, and is not intended to be an exhaustive list of all such trademarks.

- |   |                        |                            |                      |
|---|------------------------|----------------------------|----------------------|
| ACEx®   | FPST™                  | PDP-SPM™                   | SyncFET™             |
| Build it Now™   | FRFET®                 | Power220®                  | SYSTEM GENERAL®      |
| CorePLUS™   | Global Power Resource™ | Power247®                  | The Power Franchise® |
| CROSSVOLT™  | Green FPS™             | POWEREDGE®                 | the power®           |
| CTL™  | Green FPS™ e-Series™   | Power-SPM™                 | franchise            |
| Current Transfer Logic™   | GTO™                   | PowerTrench®               | TinyBoost™           |
| EcoSPARK®   | i-Lo™                  | Programmable Active Droop™ | TinyBuck™            |
| EZSWITCH™ *   | IntelliMAX™            | QFET®                      | TinyLogic®           |
|  ™ | ISOPLANAR™             | QST™                       | TINYOPTO™            |
|  ™ | MegaBuck™              | QT Optoelectronics™        | TinyPower™           |
| Fairchild®  | MICROCOUPLER™          | Quiet Series™              | TinyPWM™             |
| Fairchild Semiconductor®  | MicroFET™              | RapidConfigure™            | TinyWire™            |
| FACT Quiet Series™  | MicroPak™              | SMART START™               | µSerDes™             |
| FACT®   | MillerDrive™           | SPM®                       | UHC®                 |
| FAST®   | Motion-SPM™            | STEALTH™                   | Ultra FRFET™         |
| FastvCore™  | OPTOLOGIC®             | SuperFET™                  | UniFET™              |
| FlashWriter® *  | OPTOPLANAR®            | SuperSOT™-3                | VCX™                 |
|   |                        | SuperSOT™-6                |                      |
|   |                        | SuperSOT™-8                |                      |

\* EZSWITCH™ and FlashWriter® are trademarks of System General Corporation, used under license by Fairchild Semiconductor.

**DISCLAIMER**

FAIRCHILD SEMICONDUCTOR RESERVES THE RIGHT TO MAKE CHANGES WITHOUT FURTHER NOTICE TO ANY PRODUCTS HEREIN TO IMPROVE RELIABILITY, FUNCTION, OR DESIGN. FAIRCHILD DOES NOT ASSUME ANY LIABILITY ARISING OUT OF THE APPLICATION OR USE OF ANY PRODUCT OR CIRCUIT DESCRIBED HEREIN; NEITHER DOES IT CONVEY ANY LICENSE UNDER ITS PATENT RIGHTS, NOR THE RIGHTS OF OTHERS. THESE SPECIFICATIONS DO NOT EXPAND THE TERMS OF FAIRCHILD'S WORLDWIDE TERMS AND CONDITIONS, SPECIFICALLY THE WARRANTY THEREIN, WHICH COVERS THESE PRODUCTS.

**LIFE SUPPORT POLICY**

FAIRCHILD'S PRODUCTS ARE NOT AUTHORIZED FOR USE AS CRITICAL COMPONENTS IN LIFE SUPPORT DEVICES OR SYSTEMS WITHOUT THE EXPRESS WRITTEN APPROVAL OF FAIRCHILD SEMICONDUCTOR CORPORATION.

As used herein:

- Life support devices or systems are devices or systems which, (a) are intended for surgical implant into the body or (b) support or sustain life, and (c) whose failure to perform when properly used in accordance with instructions for use provided in the labeling, can be reasonably expected to result in a significant injury of the user.
- A critical component in any component of a life support, device, or system whose failure to perform can be reasonably expected to cause the failure of the life support device or system, or to affect its safety or effectiveness.

**PRODUCT STATUS DEFINITIONS**

**Definition of Terms**

Datasheet Identification	Product Status	Definition
Advance Information	Formative or In Design	This datasheet contains the design specifications for product development. Specifications may change in any manner without notice.
Preliminary	First Production	This datasheet contains preliminary data; supplementary data will be published at a later date. Fairchild Semiconductor reserves the right to make changes at any time without notice to improve design.
No Identification Needed	Full Production	This datasheet contains final specifications. Fairchild Semiconductor reserves the right to make changes at any time without notice to improve the design.
Obsolete	Not In Production	This datasheet contains specifications on a product that has been discontinued by Fairchild Semiconductor. The datasheet is printed for reference information only.

Rev. I32

## Looking for pricing, stock, or lifecycle information?

Click below to explore more details on WIN SOURCE:

-  [View 74ALVC245MTC on WIN SOURCE](#)
-  [Fairchild/ON Semiconductor Information](#)

## Optimize Your Supply Chain with WIN SOURCE Solutions

-  Global Sourcing Solution
-  Obsolete Management
-  Cost Control Management
-  Shortage Management
-  Alternative Solution
-  Excess Inventory Management