



**THE DATASHEET OF
SI5364-H-BL**



SONET/SDH PRECISION PORT CARD CLOCK IC

Features

- Ultra-low jitter clock outputs with jitter generation as low as 0.3 ps_{RMS}
- No external components (other than a resistor and standard bypassing)
- Up to three clock inputs
- Four independent clock outputs at 19, 155, or 622 MHz
- Stratum 3, 3E, and SMC compatible
- Digital hold for loss-of-input clock
- Automatic or manually-controlled hitless switching between clock inputs
- Revertive/non-revertive switching
- Loss-of-signal and frequency offset alarms for each clock input
- Support for forward and reverse FEC clock scaling
- 8 kHz frame sync output
- Low power
- Small size (11x11 mm)

Applications

- SONET/SDH line/port cards
- Terabit routers
- Core switches
- Digital cross connects

Description

The Si5364 is a complete solution for ultra-low jitter high-speed clock generation and distribution in precision clocking applications, such as OC-192/OC-48 SONET/SDH line/port cards. This device phase locks to one of three reference inputs in the range of 19.44 MHz and generates four synchronous clock outputs that can be independently configured for operation in the 19, 155, or 622 MHz range (1, 8, and 32x input clock). Silicon Laboratories DSPLL™ technology delivers phase-locked loop (PLL) functionality with unparalleled performance while eliminating external loop filter components, providing programmable loop parameters, and simplifying design. The on-chip reference monitoring and clock switching functions support Stratum 3/3E and SMC compatible clock switching with excellent output phase transient characteristics. FEC rates are supported with selectable 255/238 or 238/255 scaling of the clock multiplication ratios. The Si5364 establishes a new standard in performance and integration for ultra-low jitter clock generation. It operates from a single 3.3 V supply.

Functional Block Diagram

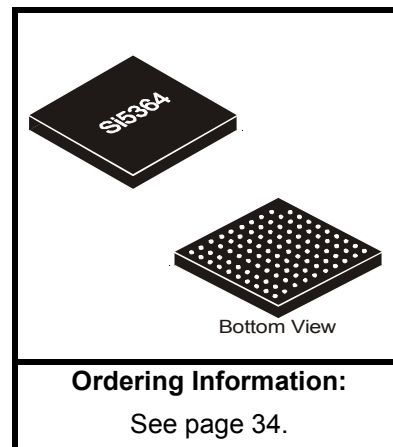
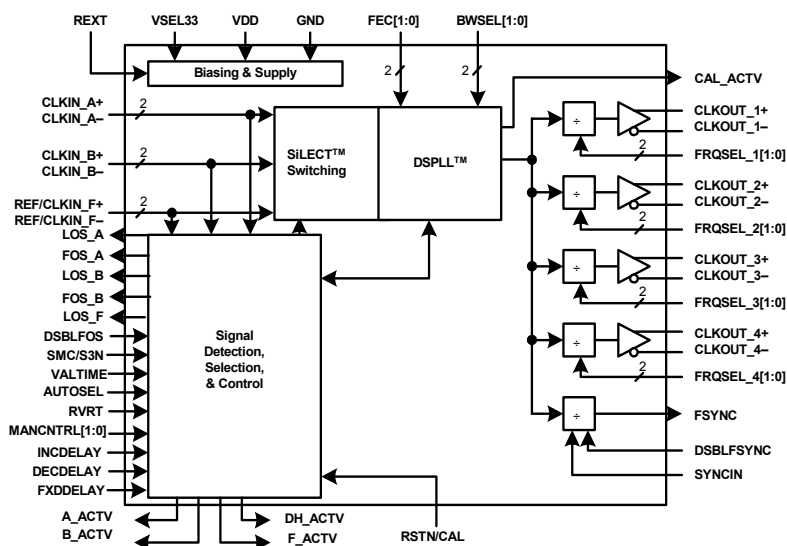

TABLE OF CONTENTS

<u>Section</u>	<u>Page</u>
1. Electrical Specifications	4
2. Functional Description	15
2.1. Clock Output Rate Selection	15
2.2. PLL Performance	16
2.3. Frequency Offset and Loss-of-Signal Alarms	17
2.4. Loss-of-Signal	17
2.5. Input Clock Select Functions	17
2.6. 8 kHz Frame Sync	20
2.7. Reset	20
2.8. PLL Self-Calibration	20
2.9. Bias Generation Circuitry	20
2.10. Differential Input Circuitry	20
2.11. Differential Output Circuitry	20
2.12. Power Supply Connections	20
2.13. Design and Layout Guidelines	21
3. Pin Descriptions: Si5364	22
4. Ordering Guide	34
5. Package Outline	35
6. 11x11 mm CBGA Card Layout	36
Document Change List	37
Contact Information	38

1. Electrical Specifications

Table 1. Recommended Operating Conditions¹

Parameter	Symbol	Test Condition	Min ¹	Typ	Max ¹	Unit
Ambient Temperature	T_A		-20 ²	25	85	°C
Si5364 Supply Voltage ³ When Using 3.3 V Supply	V_{DD33}		3.135	3.3	3.465	V

Notes:

1. All minimum and maximum specifications are guaranteed and apply across the recommended operating conditions. Typical values apply at nominal supply voltages and an operating temperature of 25 °C unless otherwise stated.
2. The Si5364 is guaranteed by design to operate at -40° C. All electrical specifications are guaranteed for an ambient temperature of -20° C to 85° C.
3. The Si5364 specifications are guaranteed when using the recommended application circuit (including component tolerance of Figure 7 on page 14.

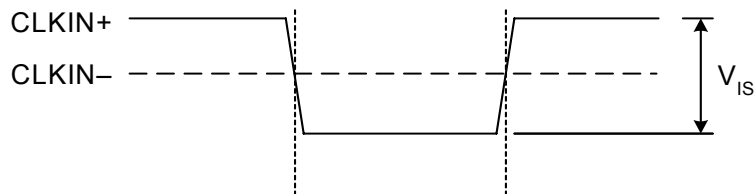

A. Operation with Single-Ended Clock Inputs*

*Note: When using single-ended clock sources, the unused clock inputs on the Si5364 must be ac-coupled to ground.

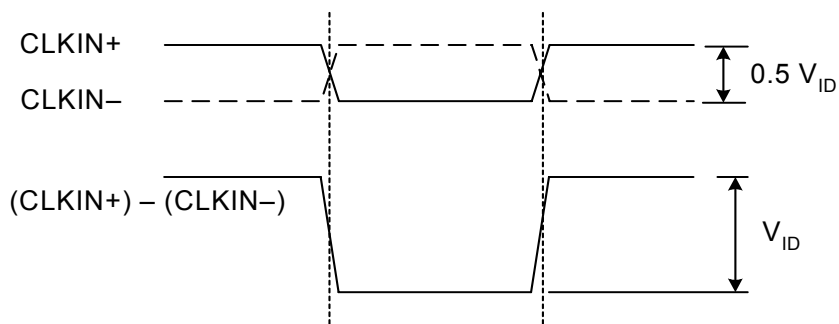

B. Operation with Differential Clock Inputs

*Note: Transmission line termination, when required, must be provided externally.

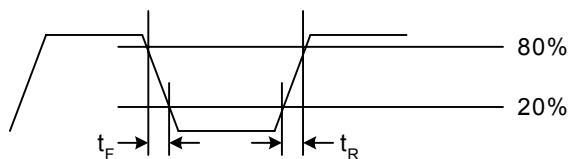
Figure 1. CLKIN Voltage Characteristics**Figure 2. Rise/Fall Time Measurement**

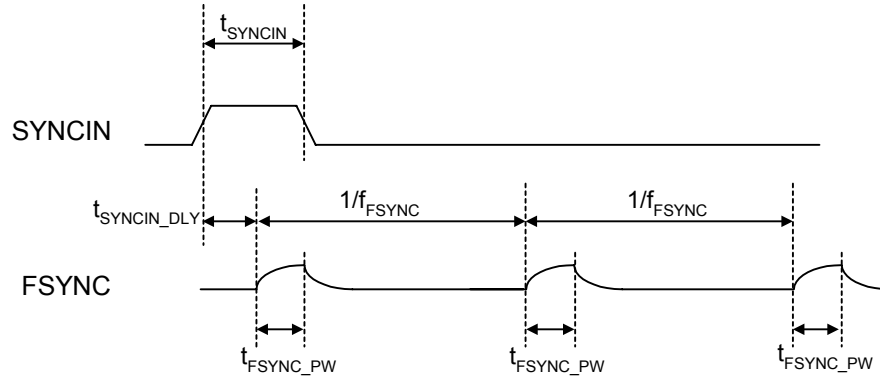

Figure 3. SYNCIN and FSYNC Timing

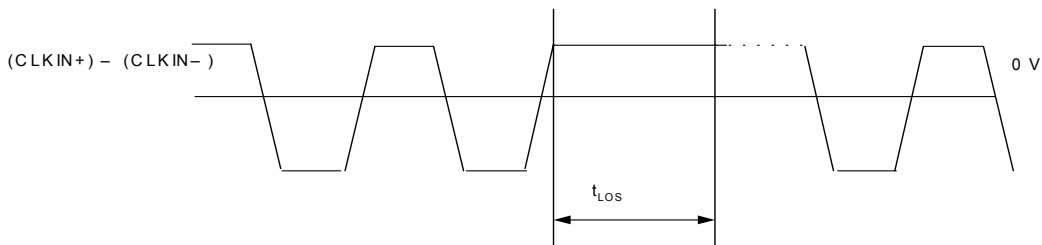

Figure 4. Transitionless Period on CLKIN for Detecting a LOS Condition

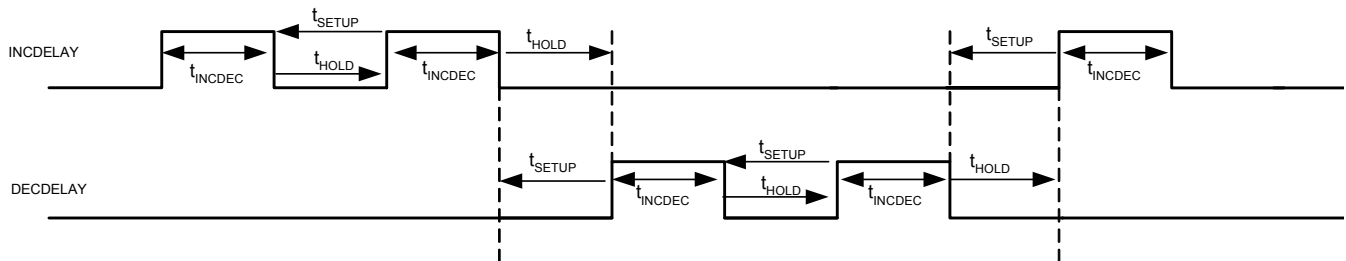

Figure 5. Clock Input to Clock Output Delay Adjustment

Table 2. DC Characteristics $(V_{DD33} = 3.3\text{ V} \pm 5\%, T_A = -20\text{ to }85\text{ }^\circ\text{C})$

Parameter	Symbol	Test Condition	Min	Typ	Max	Unit
Supply Current Single Clock Output Four Clock Outputs	I_{DD}	$f_{out} = 19.44\text{ MHz}$	—	120 212	140 240	mA
Power Dissipation Using 3.3 V Supply Single Clock Output Four Clock Outputs	P_D	$f_{out} = 19.44\text{ MHz}$	—	396 700	462 792	mW
Common Mode Input Voltage ^{1,2,3} (CLKIN_A, CLKIN_B, REF/CLKIN_F)	V_{ICM}		1.0	1.5	2.0	V
Single-Ended Input Voltage ^{2,3,4} (CLKIN_A, CLKIN_B, REF/CLKIN_F)	V_{IS}	See Figure 1A	200	—	500 ⁴	mV _{PP}
Differential Input Voltage Swing ^{2,3,4} (CLKIN_A, CLKIN_B, REF/CLKIN_F)	V_{ID}	See Figure 1B	200	—	500 ⁴	mV _{PP}
Input Impedance (CLKIN_A+, CLKIN_A-, CLKIN_B+, CLKIN_B-, REF/CLKIN_F+, REF/CLKIN_F-)	R_{IN}		—	80	—	k Ω
Differential Output Voltage Swing (CLKOUT_[3:0])	V_{OD}	100 Ω Load Line-to-Line	816	906	1100	mV _{PP}
Output Common Mode Voltage (CLKOUT_[3:0])	V_{OCM}	100 Ω Load Line-to-Line	1.4	1.8	2.2	V
Output Short to GND (CLKOUT_[3:0])	$I_{SC(-)}$		-60	—	—	mA
Output Short to V_{DD25} (CLKOUT_[3:0])	$I_{SC(+)}$		—	-45	—	mA
Input Voltage Low (LVTTTL Inputs)	V_{IL}		—	—	0.8	V
Input Voltage High (LVTTTL Inputs)	V_{IH}		2.0	—	—	V
Input Low Current (LVTTTL Inputs)	I_{IL}		—	—	50	μA
Input High Current (LVTTTL Inputs)	I_{IH}		—	—	50	μA
Input Impedance (LVTTTL Inputs)	R_{IN}		50	—	—	k Ω
Internal Pulldown (LVTTTL inputs)	I_{pd}		—	—	50	μA
FSYNC Output Charge Current	I_{OH_FSYNC}	$V_{FSYNC} = 0\text{ V}$ $C_{LOAD} = 10\text{ pF}$	100	—	—	μA
FSYNC Output Discharge Current	I_{OL_FSYNC}	$V_{FSYNC} = V_{DD}$ $C_{LOAD} = 10\text{ pF}$	320	—	—	μA

Notes:

1. The Si5364 device provides weak 1.5 V internal biasing that enables ac-coupled operation.
2. Clock inputs may be driven differentially or single-endedly. When driven single-endedly, the unused input should be ac-coupled to ground.
3. Transmission line termination, when required, must be provided externally.
4. Although the Si5364 device can operate with input clock swings as high as 1500 mV_{PP}, Silicon Laboratories recommends maintaining the input clock amplitude below 500 mV_{PP} for optimal performance.

Table 3. AC Characteristics

($V_{DD33} = 3.3\text{ V} \pm 5\%$, $T_A = -20\text{ to }85\text{ }^\circ\text{C}$)

Parameter	Symbol	Test Condition	Min	Typ	Max	Unit
Input Clock Frequency (non FEC)* FEC[1:0] = 00 (CLKIN_A, CLKIN_B, REF/ CLKIN_F)	f_{CLKIN}	No FEC Scaling	19.436	—	21.093	MHz
Input Clock Frequency (forward FEC)* FEC[1:0] = 01 (CLKIN_A, CLKIN_B, REF/ CLKIN_F)	f_{CLKIN}	255/238 FEC Scaling	18.140	—	19.687	MHz
Input Clock Frequency (reverse FEC)* FEC[1:0] = 10 (CLKIN_A, CLKIN_B, REF/ CLKIN_F)	f_{CLKIN}	238/255 FEC Scaling	20.824	—	22.600	MHz
Input Clock Rise Time (CLKIN_A, CLKIN_B, REF/CLKIN_F)	t_R	Figure 2	—	—	11	ns
Input Clock Fall Time (CLKIN_A, CLKIN_B, REF/CLKIN_F)	t_F	Figure 2	—	—	11	ns
Input Clock Duty Cycle	$C_{\text{DUTY_IN}}$		40	50	60	%
Frequency Difference at which Frequency Offset Alarm (FOS_A, FOS_B) is declared (CLKIN_A vs. REF/CLKIN_F, CLKIN_B vs. REF/CLKIN_F) SMC/S3N = 1 (SONET Min. Clock) SMC/S3N = 0 (Stratum 3/3E)	Δf_{FOS}	SMC Stratum3/3E	40 9.2	— —	72 16.6	$\pm\text{ppm}$ $\pm\text{ppm}$
CLKOUT[3:0] Frequency Range* FRQSEL[1:0] = 00 (no output) FRQSEL[1:0] = 01 (1X) FRQSEL[1:0] = 10 (8X) FRQSEL[1:0] = 11 (32X)	f_{O_19} f_{O_155} f_{O_622}		— 19.436 155.48 621.95	— — — —	— 21.093 168.75 675.0	MHz MHz MHz
CLKOUT_[3:0] Rise Time	t_R	Figure 2; single-ended; after 3 cm of 50 Ω FR4 stripline	—	187	260	ps
CLKOUT_[3:0] Fall Time	t_F	Figure 2; single-ended; after 3 cm of 50 Ω FR4 stripline	—	176	260	ps
Output Clock Duty Cycle	$C_{\text{DUTY_OU}}T$	Differential: (CLKOUT+) – (CLKOUT–)	48	—	52	%
*Note: The Si5364 provides a 1, 8, or 32x clock frequency multiplication function with an option for additional frequency scaling by a factor of 255/238 or 238/255 for FEC rate compatibility.						

Table 3. AC Characteristics (Continued) $(V_{DD33} = 3.3\text{ V} \pm 5\%, T_A = -20\text{ to }85\text{ }^\circ\text{C})$

Parameter	Symbol	Test Condition	Min	Typ	Max	Unit
SYNCIN Pulse Width	t_{SYNCIN}	Figure 3	20	—	—	ns
FSYNC Frequency	f_{FSYNC}	Figure 3	—	$f_{O_19}/2430$	—	kHz
FSYNC Pulse Width	$t_{\text{FSYNC_PW}}$	Figure 3	—	$16/f_{O_19}$	—	s
SYNCIN to FSYNC	$t_{\text{SYNCIN_DL}}_Y$	Figure 3	38	45	52	ns
Phase Skew Between Outputs	t_{skew}		—	—	400	ps
RSTN/CAL Pulse Width	t_{RSTN}		20	—	—	ns
INCDELAY, DECDELAY Pulse Width	t_{INCDEC}	Figure 5	1	—	—	μs
INCDELAY, DECDELAY Setup Time	t_{SETUP}	Figure 5	1	—	—	μs
INCDELAY, DECDELAY Hold Time	t_{HOLD}	Figure 5	1	—	—	μs
Transitionless Period Required on CLKIN for Detecting an LOS Condition	t_{LOS}	Figure 4	$24/f_{O_622}$	—	$32/f_{O_622}$	s
Recovery Time for Clearing an LOS or FOS Condition VALTIME = 0 VALTIME = 1	t_{VAL}	Measured from when a valid reference clock is applied until the applicable LOS or FOS flag clears	0.09 12.0	— —	0.22 14.1	s
*Note: The Si5364 provides a 1, 8, or 32x clock frequency multiplication function with an option for additional frequency scaling by a factor of 255/238 or 238/255 for FEC rate compatibility.						

Table 4. AC Characteristics (PLL Performance Characteristics) $(V_{DD33} = 3.3\text{ V} \pm 5\%, T_A = -20\text{ to }85\text{ }^\circ\text{C})$

Parameter	Symbol	Test Condition	Min	Typ	Max	Unit
Wander/Jitter at 800 Hz Bandwidth (BWSEL[1:0] = 10)						
Jitter Tolerance (See Figure 8)	$J_{\text{TOL(PP)}}$	f = 8 Hz	1000	—	—	ns
		f = 80 Hz	100	—	—	ns
		f = 800 Hz	10	—	—	ns
CLKOUT RMS Jitter Generation FEC[1:0] = 00 (1/1 Scaling)	$J_{\text{GEN(RMS)}}$	12 kHz to 20 MHz	—	0.87	1.2	ps
		50 kHz to 80 MHz	—	0.26	0.35	ps
Notes:						
1. Higher PLL bandwidth settings provide smaller clock output wander with temperature gradient.						
2. For reliable device operation, temperature gradients should be limited to 10 °C/min.						
3. Telcordia GR-1244-CORE requirements specify maximum phase transient slope during clock rearrangement in terms of nanoseconds per millisecond. The equivalent ps/ μs unit is used here since the maximum phase transient magnitude for the Si5364 ($t_{\text{PT_MTIE}}$) never reaches one nanosecond.						

Table 4. AC Characteristics (PLL Performance Characteristics) (Continued)

 $(V_{DD33} = 3.3 \text{ V} \pm 5\%, T_A = -20 \text{ to } 85 \text{ }^\circ\text{C})$

Parameter	Symbol	Test Condition	Min	Typ	Max	Unit
CLKOUT RMS Jitter Generation FEC[1:0] = 01, 10 (255/238, 238/255 Scaling)	$J_{GEN(RMS)}$	12 kHz to 20 MHz	—	0.86	1.2	ps
		50 kHz to 80 MHz	—	0.26	0.35	ps
CLKOUT Peak-Peak Jitter Generation FEC[1:0] = 00 (1/1 Scaling)	$J_{GEN(PP)}$	12 kHz to 20 MHz	—	6.1	10.0	ps
		50 kHz to 80 MHz	—	2.1	5.0	ps
CLKOUT Peak-Peak Jitter Generation FEC[1:0] = 01, 10 (255/238, 238/255 Scaling)	$J_{GEN(PP)}$	12 kHz to 20 MHz	—	6.0	10.0	ps
		50 kHz to 80 MHz	—	2.0	5.0	ps
Jitter Transfer Bandwidth (See Figure 9)	F_{BW}	BW = 800 Hz	—	800	—	Hz
Wander/Jitter Transfer Peaking	J_P	< 800 Hz	—	0.0	0.05	dB
Wander/Jitter at 1600 Hz Bandwidth (BWSEL[1:0] = 01)						
Jitter Tolerance (see Figure 8)	$J_{TOL(PP)}$	f = 16 Hz	1000	—	—	ns
		f = 160 Hz	100	—	—	ns
		f = 1600 Hz	10	—	—	ns
CLKOUT RMS Jitter Generation FEC[1:0] = 00	$J_{GEN(RMS)}$	12 kHz to 20 MHz	—	0.83	1.0	ps
		50 kHz to 80 MHz	—	0.26	0.35	ps
CLKOUT RMS Jitter Generation FEC[1:0] = 01, 10	$J_{GEN(RMS)}$	12 kHz to 20 MHz	—	0.8	1.0	ps
		50 kHz to 80 MHz	—	0.26	0.35	ps
CLKOUT Peak-Peak Jitter Generation FEC[1:0] = 00	$J_{GEN(PP)}$	12 kHz to 20 MHz	—	5.7	9.0	ps
		50 kHz to 80 MHz	—	2.0	5.0	ps
CLKOUT Peak-Peak Jitter Generation FEC[1:0] = 01, 10	$J_{GEN(PP)}$	12 kHz to 20 MHz	—	5.4	9.0	ps
		50 kHz to 80 MHz	—	1.9	5.0	ps
Jitter Transfer Bandwidth (see Figure 9)	F_{BW}	BW = 1600 Hz	—	1600	—	Hz
Wander/Jitter Transfer Peaking	J_P	< 1600 Hz	—	0.0	0.1	dB
Wander/Jitter at 3200 Hz Bandwidth (BWSEL[1:0] = 00)						
Jitter Tolerance (see Figure 8)	$J_{TOL(PP)}$	f = 32 Hz	1000	—	—	ns
		f = 320 Hz	100	—	—	ns
		f = 3200 Hz	10	—	—	ns
CLKOUT RMS Jitter Generation FEC[1:0] = 00 (1/1 Scaling)	$J_{GEN(RMS)}$	12 kHz to 20 MHz	—	0.89	1.2	ps
		50 kHz to 80 MHz	—	0.3	0.4	ps
CLKOUT RMS Jitter Generation FEC[1:0] = 01, 10 (255/238, 238/255 Scaling)	$J_{GEN(RMS)}$	12 kHz to 20 MHz	—	0.81	1.2	ps
		50 kHz to 80 MHz	—	0.30	0.4	ps
CLKOUT Peak-Peak Jitter Generation FEC[1:0] = 00 (1/1 Scaling)	$J_{GEN(PP)}$	12 kHz to 20 MHz	—	5.8	10.0	ps
		50 kHz to 80 MHz	—	2.9	5.0	ps
Notes:						
1. Higher PLL bandwidth settings provide smaller clock output wander with temperature gradient.						
2. For reliable device operation, temperature gradients should be limited to 10 °C/min.						
3. Telcordia GR-1244-CORE requirements specify maximum phase transient slope during clock rearrangement in terms of nanoseconds per millisecond. The equivalent ps/μs unit is used here since the maximum phase transient magnitude for the Si5364 (t_{PT_MTIE}) never reaches one nanosecond.						

Table 4. AC Characteristics (PLL Performance Characteristics) (Continued) $(V_{DD33} = 3.3\text{ V} \pm 5\%, T_A = -20\text{ to }85\text{ }^\circ\text{C})$

Parameter	Symbol	Test Condition	Min	Typ	Max	Unit
CLKOUT Peak-Peak Jitter Generation FEC[1:0] = 01, 10 (255/238, 238/255 Scaling)	$J_{GEN(PP)}$	12 kHz to 20 MHz	—	7.9	10.0	ps
		50 kHz to 80 MHz	—	4.6	5.0	ps
Jitter Transfer Bandwidth (see Figure 9)	F_{BW}	BW = 3200 Hz	—	3200	—	Hz
Wander/Jitter Transfer Peaking	J_P	< 3200 Hz	—	0.0	0.05	dB
Wander/Jitter at 6400 Hz Bandwidth (BWSEL[1:0] = 11)						
Jitter Tolerance (see Figure 8)	$J_{TOL(PP)}$	f = 64 Hz	1000	—	—	ns
		f = 640 Hz	100	—	—	ns
		f = 6400 Hz	10	—	—	ns
CLKOUT RMS Jitter Generation FEC[1:0] = 00 (1/1 Scaling)	$J_{GEN(RMS)}$	12 kHz to 20 MHz	—	1.03	1.4	ps
		50 kHz to 80 MHz	—	0.38	0.5	ps
CLKOUT RMS Jitter Generation FEC[1:0] = 01, 10 (255/238, 238/255 scaling)	$J_{GEN(RMS)}$	12 kHz to 20 MHz	—	1.01	1.4	ps
		50 kHz to 80 MHz	—	0.45	0.6	ps
CLKOUT Peak-Peak Jitter Generation FEC[1:0] = 00 (1/1 Scaling)	$J_{GEN(PP)}$	12 kHz to 20 MHz	—	9.3	12.0	ps
		50 kHz to 80 MHz	—	2.8	5.5	ps
CLKOUT Peak-Peak Jitter Generation FEC[1:0] = 01, 10 (255/238, 238/255 scaling)	$J_{GEN(PP)}$	12 kHz to 20 MHz	—	7.1	12.0	ps
		50 kHz to 80 MHz	—	3.0	5.5	ps
Jitter Transfer Bandwidth (see Figure 9)	F_{BW}	BW = 6400 Hz	—	6400	—	Hz
Wander/Jitter Transfer Peaking	J_P	< 6400 Hz	—	0.05	.1	dB
Acquisition Time	T_{AQ}	RSTN/CAL high to CAL_ACTV low, with valid clock input and VALTIME = 0	—	195	350	ms
Clock Output Wander with Temperature Gradient ^{1,2}	C_{CO_TG}	Stable Input Clock; Temperature Gradient < 10 °C/min; 800 Hz Loop BW	—	—	40	ps/ °C/ min
Initial Frequency Accuracy in Digital Hold Mode (first 100 ms with supply voltage and temperature held constant)	C_{DH_FA}	Stable Input Clock Selected until entering Digital Hold	—	—	7.0	ppm
Clock Output Frequency Accuracy Over Temperature in Digital Hold Mode	C_{DH_T}	Constant Supply Voltage	—	16.2	30	ppm/ °C
Clock Output Frequency Accuracy Over Supply Voltage in Digital Hold Mode	C_{DH_V33}	Constant Temperature	—	25	500	ppm/ V
Clock Output Phase Step	t_{PT_MTIE}	During Clock Switching 1/1	-200	0	200	ps
Notes:						
1. Higher PLL bandwidth settings provide smaller clock output wander with temperature gradient.						
2. For reliable device operation, temperature gradients should be limited to 10 °C/min.						
3. Telcordia GR-1244-CORE requirements specify maximum phase transient slope during clock rearrangement in terms of nanoseconds per millisecond. The equivalent ps/μs unit is used here since the maximum phase transient magnitude for the Si5364 (t_{PT_MTIE}) never reaches one nanosecond.						

Table 4. AC Characteristics (PLL Performance Characteristics) (Continued)

($V_{DD33} = 3.3\text{ V} \pm 5\%$, $T_A = -20\text{ to }85\text{ }^\circ\text{C}$)

Parameter	Symbol	Test Condition	Min	Typ	Max	Unit
Clock Output Phase Step Slope ³ —Manual Switches BWSEL[1:0] = 11 BWSEL[1:0] = 00 BWSEL[1:0] = 01 BWSEL[1:0] = 10	m_{PT}	During Clock Switching				
		6400 Hz	—	—	10	ps/
		3,200 Hz	—	—	5	μs
		1600 Hz	—	—	2.5	
		800 Hz	—	—	1.25	
Clock Output Phase Step Slope ³ —Auto Switching BWSEL[1:0] = 11 BWSEL[1:0] = 00 BWSEL[1:0] = 01 BWSEL[1:0] = 10	m_{PT}	During Clock Switching				
		6400 Hz	—	—	36	ps/
		3200 Hz	—	—	18	μs
		1600 Hz	—	—	9.0	
		800 Hz	—	—	4.5	
Transient Phase Deviation During Clock Auto Switching BWSEL[1:0] = 11 BWSEL[1:0] = 00 BWSEL[1:0] = 01 BWSEL[1:0] = 10	$t_{pt_mtie_max}$					
		6400 Hz	—	—	800	ps
		3200 Hz	—	—	800	
		1600 Hz	—	—	800	
		800 Hz	—	—	800	

Notes:

- Higher PLL bandwidth settings provide smaller clock output wander with temperature gradient.
- For reliable device operation, temperature gradients should be limited to 10 °C/min.
- Telcordia GR-1244-CORE requirements specify maximum phase transient slope during clock rearrangement in terms of nanoseconds per millisecond. The equivalent ps/ μs unit is used here since the maximum phase transient magnitude for the Si5364 (t_{PT_MTIE}) never reaches one nanosecond.

Table 5. Absolute Maximum Ratings

Parameter	Symbol	Value	Unit
3.3 V DC Supply Voltage	V_{DD33}	-0.5 to 3.6	V
LVTTL Input Voltage	V_{DIG}	-0.3 to (+3.6)	V
Maximum Current Any Output PIN		± 50	mA
Operating Junction Temperature	T_{JCT}	-55 to 150	$^\circ\text{C}$
Storage Temperature Range	T_{STG}	-55 to 150	$^\circ\text{C}$
ESD HBM Tolerance (100 pf, 1.5 k Ω)		1.0	kV

Note: Permanent device damage can occur if the Absolute Maximum Ratings are exceeded. Restrict functional operation to the conditions as specified in the operational sections of this data sheet. Exposure to absolute maximum rating conditions for extended periods might affect device reliability.

Table 6. Thermal Characteristics

Parameter	Symbol	Test Condition	Value	Unit
Thermal Resistance Junction to Ambient	θ_{JA}	Still Air	34.9	$^\circ\text{C/W}$

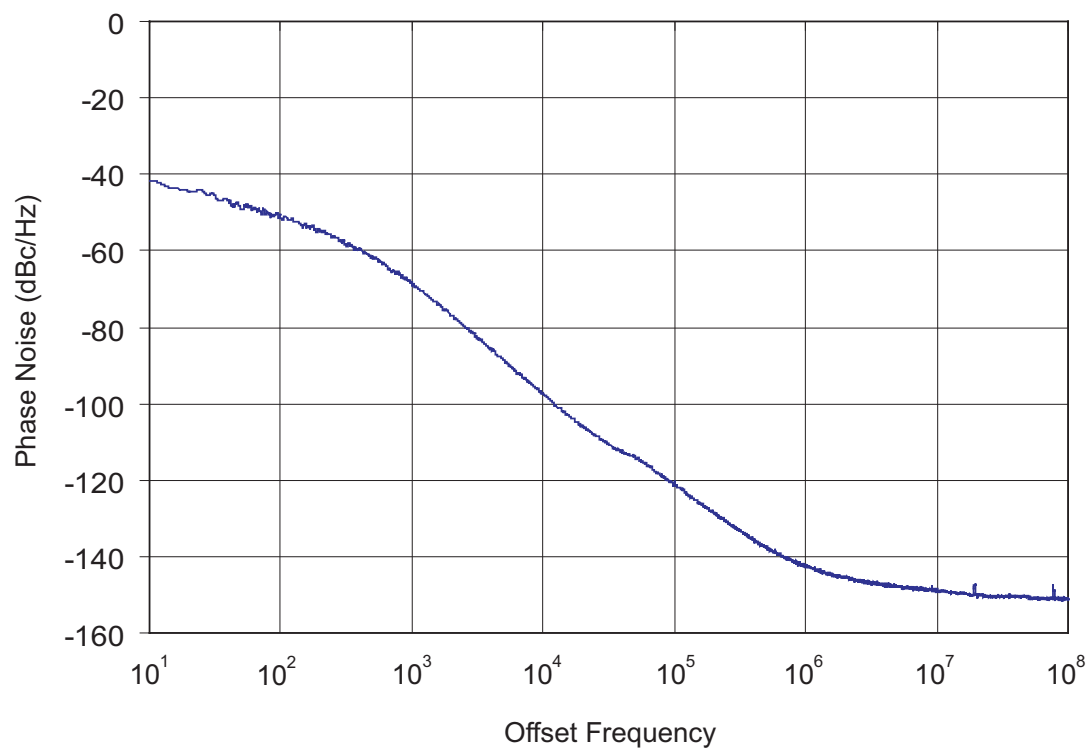

Figure 6. Typical Si5364 Phase Noise (CLKIN = 19.44 MHz, CLKOUT = 622.08 MHz, and Loop BW = 800 Hz)

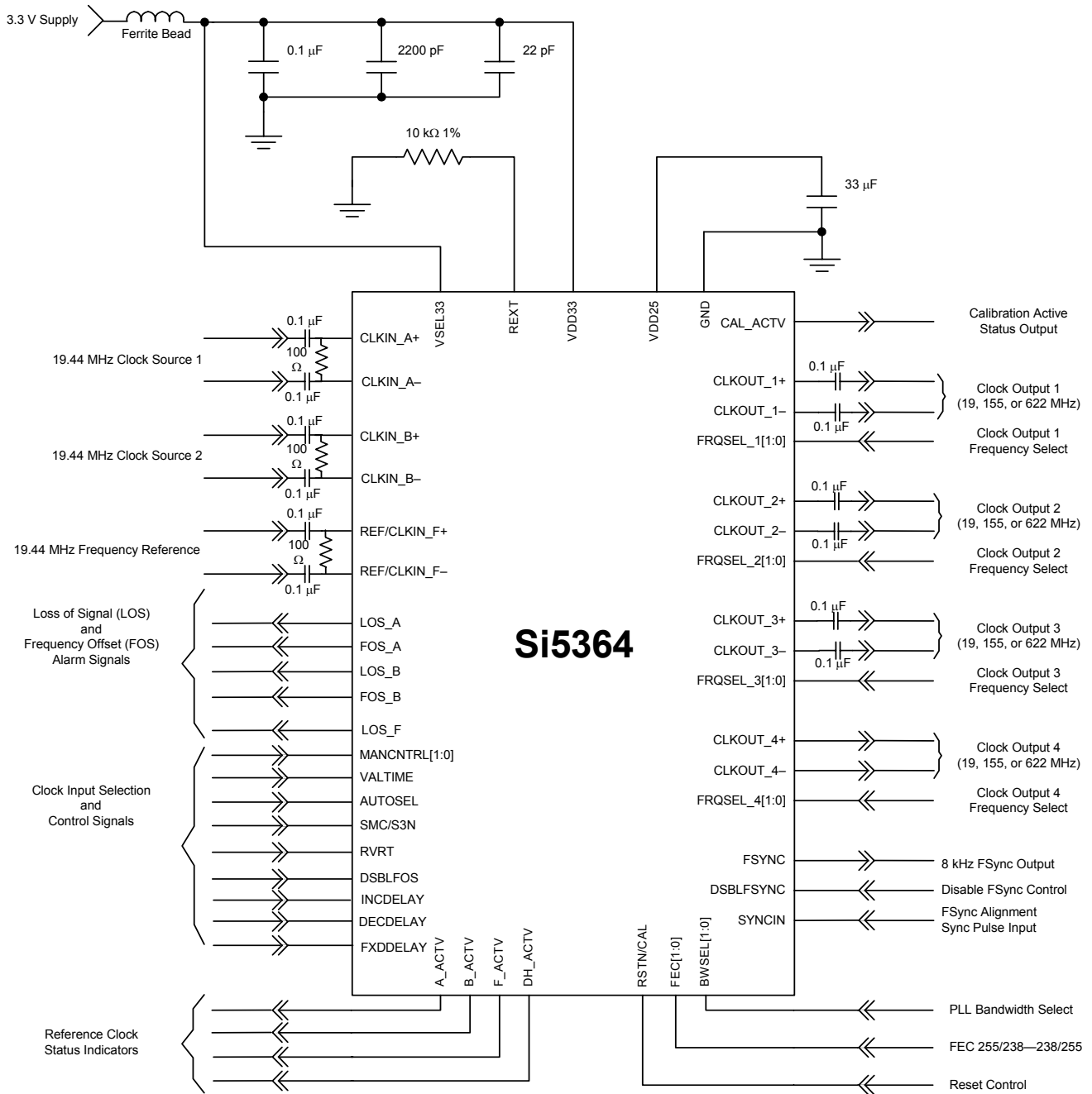

Figure 7. Si5364 Typical Application Circuit (3.3 V Supply)

2. Functional Description

The Si5364 is a high-performance precision clock switching and clock generation device. The Si5364 accepts up to three clock inputs in the 19 MHz range, selects one of these clocks as the active clock input, and generates up to four high-quality clock outputs that are individually-programmable to be 1, 8, or 32x the input clock frequency. Additional optional scaling by a factor of 255/238 or 238/255 provides compatibility with systems that provide or require clocks that are scaled for forward error correction (FEC) rates. A typical application for the Si5364 in SONET/SDH systems is the generation of multiple low-jitter 19.44, 155.52, or 622.08 MHz clock outputs from a single or multiple (redundant) 19.44 MHz reference clock sources.

The Si5364 employs Silicon Laboratories' DSPLL technology to provide excellent jitter performance, minimize the external component count, and maximize flexibility and ease of use. The Si5364's DSPLL phase locks to the selected clock input signal, attenuates significant amounts of jitter, and multiplies the clock frequency to generate the device's SONET/SDH-compatible clock outputs. The DSPLL loop bandwidth is selectable, allowing the Si5364's jitter performance to be optimized for different applications. The Si5364 can produce clock outputs with jitter generation as low as 0.30 pS_{RMS} (see Table 4 on page 9), making the device an ideal solution for port card clocking in SONET/SDH (including OC-48 and OC-192) and Gigabit Ethernet systems.

Input clock selection and switching occurs manually or automatically. Automatic switching is revertive or non-revertive. The Si5364 monitors the clock input signals for frequency accuracy and loss-of-signal and provides frequency offset (FOS) and loss-of-signal (LOS) alarms that are the basis for manual or automatic clock selection decisions. Input clock switching in the Si5364 uses Silicon Laboratories' switching technology to minimize the clock output phase transients normally associated with clock rearrangement (switching). The resulting Maximum Time Interval Error (MTIE) associated with switching in the Si5364 is well below the limits specified in Telcordia Technologies GR-1244-CORE for Stratum 2 and 3E clocks or Stratum 3 and 4E clocks.

The Si5364's PLL utilizes Silicon Laboratories' DSPLL technology to eliminate jitter, noise, and the need for external loop filter components found in traditional PLL implementations. A digital signal processing (DSP) algorithm replaces the loop filter commonly found in analog PLL designs. This algorithm processes the phase detector error term and generates a digital control value to adjust the frequency of the voltage-controlled oscillator (VCO). The technology produces

low phase noise clocks with less jitter than is generated using traditional methods. See Figure 6 for an example phase noise plot. In addition, because external loop filter components are not required, sensitive noise entry points are eliminated, and the DSPLL is less susceptible to board-level noise sources. Digital technology provides highly-stable and consistent operation over all process, temperature, and voltage variations. The benefits are smaller, lower power, cleaner, more reliable, and easier-to-use clock circuits.

2.0.1. Selectable Loop Filter Bandwidth

The digital nature of the DSPLL loop filter gives control of the loop parameters without changing external components. The Si5364 provides four selectable loop bandwidth settings (800, 1600, 3200, or 6400 Hz) for different system requirements. The loop bandwidth is selected using the BWSEL[1:0] pins. The BWSEL[1:0] settings and associated loop bandwidths are listed in Table 7.

Table 7. Loop Bandwidth Settings

Loop Bandwidth	BWSEL1	BWSEL0
6400 Hz	1	1
3200 Hz	0	0
1600 Hz	0	1
800 Hz	1	0

Table 8. Nominal Clock Out Frequencies

Output Clock Frequency	FSEL1	FSEL0
622.08 MHz (32x multiplier)	1	1
155.52 MHz (8x multiplier)	1	0
19.44 MHz (1x multiplier)	0	1
Driver Powerdown	0	0

2.1. Clock Output Rate Selection

The Si5364's DSPLL phase locks to the selected clock input signal to generate an internal VCO frequency that is a multiple of the input clock frequency. The internal VCO frequency is divided down to produce four clock outputs at 1, 8, or 32x the frequency of the clock input signal. The clock rate for each clock output is selected using the Frequency Select (FRQSEL[1:0]) pins associated with that output. The FRQSEL[1:0] settings and associated clock rates are listed in Table 8.

The input frequency ranges for the Si5364 are specified in Table 3 on page 8. The output rates scale accordingly. When a 19.44 MHz input clock is used, the clock outputs are programmable to run at 19.44, 155.52, or 622.08 MHz.

2.1.1. FEC Rate Conversion

Conversion from non-FEC to FEC rates and from FEC to non-FEC rates is supported with selectable 238/255 or 255/238 scaling of the Si5364's clock output multiplication ratios.

The multiplication ratios and associated frequency ranges for the Si5364 clock outputs are set by the FRQSEL[1:0] pins associated with each clock output. Additional frequency scaling of active clock outputs by a factor of either 238/255 or 255/238 is selected using the FEC[1:0] control inputs.

For example, a 622.08 MHz output clock (a non-FEC rate) is generated from a 19.44 MHz input clock (a non-FEC rate) by setting FRQSEL[1:0] = 11 (32x multiplication) and setting FEC[1:0] = 00 (no FEC scaling). A 666.51 MHz output clock (a FEC rate) is generated from a 19.44 MHz input clock (a non-FEC rate) by setting FRQSEL[1:0] = 11 (32x multiplication) and setting FEC[1:0] = 01 (255/238 FEC scaling). Finally, a 622.08 MHz output clock (a non-FEC rate) is generated from a 20.83 MHz input clock (a FEC rate) by setting FRQSEL [1:0] = 11 (32x multiplication) and setting FEC[1:0] = 10 (238/255 FEC scaling). The FEC[1:0] settings and associated scaling factors are listed in Table 9.

Table 9. FEC Rate Conversion

FEC Frequency Scaling	FEC1	FEC0	FSYNC
1/1	0	0	Enabled
255/238	0	1	Disabled
238/255	1	0	Enabled
Reserved	1	1	

2.2. PLL Performance

The Si5364 PLL provides extremely low jitter generation, high jitter tolerance, and a well-controlled jitter transfer function with low peaking and a high degree of jitter attenuation. Each of these key performance parameters is described in the following sections.

2.2.1. Jitter Tolerance

Jitter tolerance for the Si5364 is defined as the maximum peak-to-peak sinusoidal jitter that can be present on the incoming clock. Tolerance is a function of the input jitter frequency and improves for lower input jitter frequency.

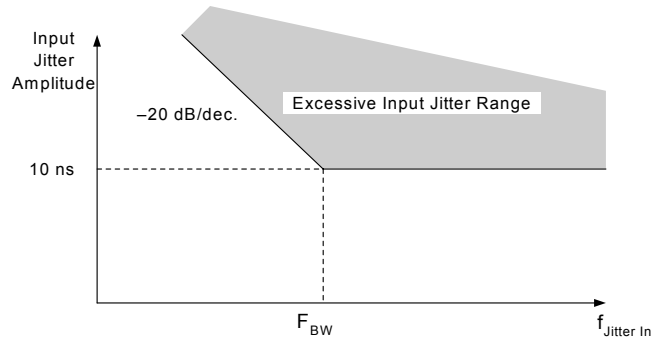

Figure 8. Jitter Tolerance Mask/Template

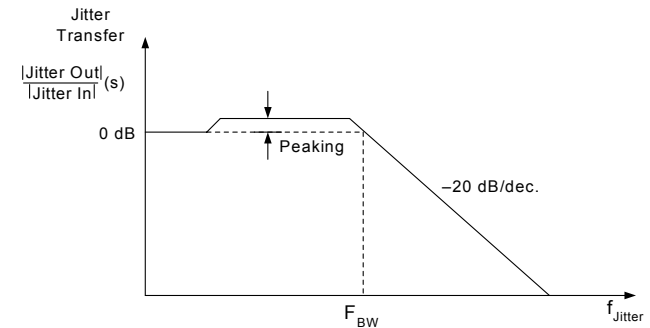

Figure 9. PLL Jitter Transfer Mask/Template

2.2.2. Jitter Transfer

Jitter transfer is defined as the ratio of output signal jitter to input signal jitter for a specified jitter frequency. The jitter transfer characteristic determines the amount of input clock jitter that passes to the outputs. The DSPLL technology used in the Si5364 provides tightly controlled jitter transfer curves because the PLL gain parameters are determined by digital circuits that do not vary over supply voltage, process, and temperature. In a system application, a well-controlled transfer curve minimizes the output clock jitter variation from board to board for consistent system-level jitter performance.

The jitter transfer characteristic is a function of the BWSEL[1:0] setting. Lower bandwidth selection results in more jitter attenuation of the incoming clock but might result in higher jitter generation. Table 4 on page 9 gives the 3 dB bandwidth and peaking values for specified BWSEL[1:0] settings. Figure 9 shows the jitter transfer curve mask.

2.2.3. Jitter Generation

Jitter generation is defined as the amount of jitter produced at the output of the device with a jitter-free input clock. Jitter is generated from sources within the VCO and other PLL components. Jitter generation is a function of the PLL bandwidth setting.

2.3. Frequency Offset and Loss-of-Signal Alarms

The Si5364 monitors the input clock signals and provides alarm output signals for frequency offset and loss-of-signal that is the basis for manual or automatic clock input switching decisions.

The frequency offset alarms indicate if the CLKIN_A and CLKIN_B input clocks are within a specified frequency precision relative to the frequency of the REF/CLKIN_F input. The REF/CLKIN_F input can also be utilized as a third clock input for the DSPLL. The frequency offset monitoring circuitry compares the frequency of the CLKIN_A and CLKIN_B input clocks with the frequency of the supplied reference clock (REF/CLKIN_F). If the frequency offset of an input clock exceeds a preset frequency offset threshold, a frequency offset alarm (FOS) is declared for that clock input. The frequency offset threshold is selectable for compatibility with either SONET minimum clock (SMC) or Stratum 3/3E requirements using the SMC/S3N control input. Frequency offset threshold values are indicated in Table 3 on page 8.

2.4. Loss-of-Signal

The Si5364 loss-of-signal (LOS) circuitry constantly monitors the CLKIN_A, CLKIN_B, and REF/CLKIN_F input clocks for missing pulses. It over-samples the input clocks to search for extended periods of time without clock transitions. If the LOS circuitry detects four consecutive samples of an input clock that are the same state (i.e., 1111 or 0000), an LOS is declared for that input clock. The LOS circuitry runs at a frequency of $f_{0_622}/8$, where f_{0_622} is the output clock frequency when the FRQSEL[1:0] pins are set to 11. Figure 4 on page 6 and Table 3 on page 8 list the minimum and maximum transitionless time periods required for declaring an LOS on an input clock.

Once an LOS flag is asserted on one of the input clocks, it is held high until the input clock is validated over a time period designated by the VALTIME pin. When VALTIME is low, the validation time period is about 100 ms. When VALTIME is high, the validation time period is about 13 s. If another LOS condition on the same input clock is detected during the validation time (i.e., if another set of 1111 or 0000 samples are detected), the LOS flag remains asserted, and the validation time starts over.

An LOS alarm on the REF/CLKIN_F clock input automatically disables the FOS_A and FOS_B frequency offset alarms (frequency offset alarms are automatically disabled in applications that do not supply a REF/CLKIN_F input to the Si5364). The FOS_A and FOS_B frequency offset alarms can be disabled

manually with the DSBLFOS control input.

2.5. Input Clock Select Functions

The Si5364 provides hitless switching between clock input sources. Switching is controlled automatically or manually. The criteria for automatic switching are described below. Automatic switching can be revertive (returns to the original clock when the alarm condition clears) or non-revertive. When in manual mode, the device selects the clock specified by the value of the MANCNTRL[1:0] inputs.

2.5.1. Hitless Switching

Silicon Laboratories switching technology performs “phase build-out” to minimize the propagation of phase transients to the clock outputs during input clock switching. Many of the problems associated with clock switching using traditional analog solutions are eliminated. In the Si5364, all switching between input clocks occurs within the input multiplexor and DSPLL phase detector circuitry. The phase detector circuitry continually monitors the phase difference between each input clock and the DSPLL VCO clock output. The phase detector circuitry can lock to a clock signal at a specified phase offset relative to the VCO output so that the phase offset is maintained by the DSPLL circuitry. At the time a clock switch occurs, the phase detector circuitry knows both the input-to-output phase relationship for the original input clock and of the new input clock. The phase detector circuitry locks to the new input clock at the new clock’s phase offset so that the phase of the output clock is not disturbed. That is, the phase difference between the two input clocks is absorbed in the phase detector’s offset value, rather than being propagated to the clock output.

The switching technology virtually eliminates the output clock phase transients traditionally associated with clock rearrangement (input clock switching). SONET/SDH specifications allow transients of up to 150 ns of maximum time interval error (MTIE) to occur during a Stratum 2/3E clock switch. This specification, which is sometimes difficult to meet with analog implementations, allows for up to 1500 bit periods of slip to occur in an OC192 data stream. Silicon Laboratories’ switching eliminates these bit slips and the limitations imposed by analog methods (such as low bandwidth loops on the port cards) to meet the SONET/SDH requirements. The MTIE and maximum slope for clock output phase transients during clock switching with the Si5364 are given in Table 4 on page 9. These values fall significantly below the limits specified in the Telcordia GR-1244-CORE Requirements.

The characteristic of the phase transient specification is defined in Figure 10. The clock output phase step

(t_{PT_MTIE}) is the steady-state offset between pre-switching and post-switching output phases. This specification applies to both the manual and automatic switch modes. The clock output phase step slope (M_{PT}) is defined as the rate of change of the output clock phase during transition. Its magnitude depends on the setting of the BWSEL[1:0] pins and whether the switching is triggered manually by users or automatically by Si5364 due to the changed input clocks. The maximum transient phase deviation ($t_{PT_MTIE_MAX}$) only applies to an automatic switch and is defined as the maximum transient phase disturbance on the output clock. This transient only occurs in the automatic mode due to the delay between the actual loss of the clock and when the LOS detection circuitry detects the loss. During the delay, the phase detector measures the phase change of the “lost” clock, and the DSPLL moves the output clock’s phase accordingly. When the LOS circuitry flags the loss of the clock, Si5364 switches the reference to the alternate clock. Since the internal phase monitor circuitry preserves the phase difference before the event (loss of the original clock), the output phase is restored, and no excessive phase deviation is present.

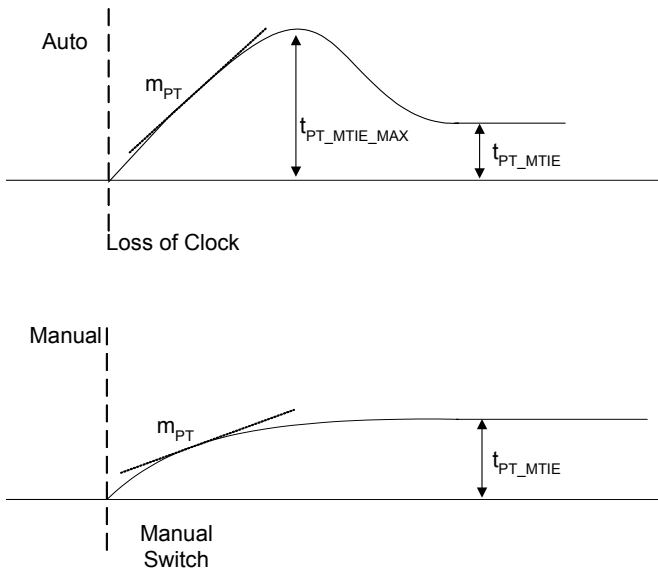

Figure 10. Phase Transient Specification

2.5.2. Automatic Switching

The Si5364 provides automatic and manual control over which input clock drives the DSPLL. Automatic switching is selected when the AUTOSEL input is high. Automatic switching is either revertive (return to the default input after alarm conditions clear) or non-revertive (remain with selected input until an alarm condition exists on the selected input).

The prioritization of clock inputs for automatic switching is CLKA, followed by CLKB, REF/CLKIN_F, and finally, digital hold mode. Automatic switching mode defaults to CLKIN_A at powerup, reset, or when in revertive mode with no alarms present on CLKIN_A. If a LOS or FOS alarm occurs on CLKIN_A and there are no active alarms on CLKIN_B, the device switches to CLKIN_B. If both CLKIN-A and CLKIN_B are alarmed and REF/CLKIN_F is present and alarm-free, the device switches to REF/CLKIN_F. If no REF/CLKIN_F is present and CLKIN_A and CLKIN_B are alarmed, the internal oscillator digitally holds its last value. If automatic mode is selected and DSBLFOS is active, automatic switching is not initiated in response to FOS alarms.

2.5.3. Revertive/Non-Revertive Switching

In automatic switching mode, an alarm condition on the selected input clock causes an automatic switch to the highest priority non-alarmed input available. Automatic switching is revertive or non-revertive, depending on the state of the RVRT input. In revertive mode, if an alarm condition on the currently-selected input clock causes a switch to a lower priority input clock, the Si5364 switches to the original clock input when the alarm condition is cleared. In revertive mode, the highest priority reference source that is valid is selected as the DSPLL input. In non-revertive mode, the current clock selection remains as long as the selected clock is valid even if alarms are cleared on a higher priority clock. Figure 11 provides state diagrams for revertive mode switching and for non-revertive mode switching.

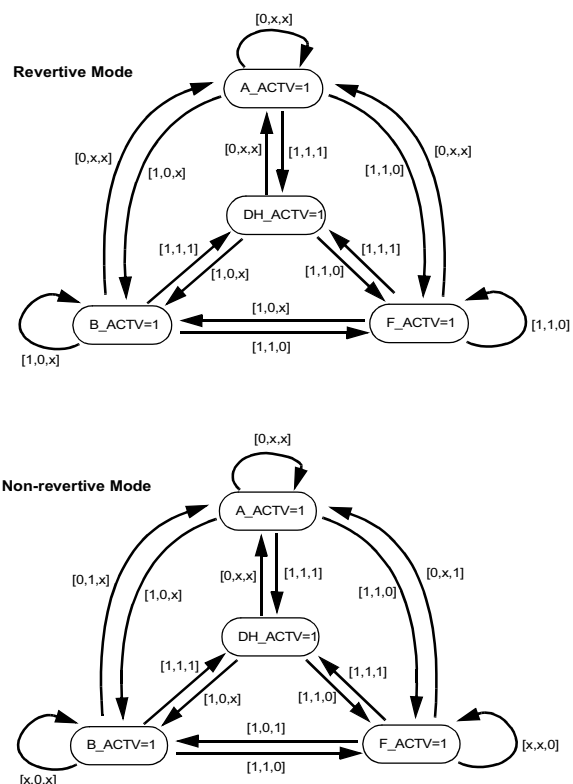
**Notes:**

- Criteria to determine input switch: [A_fail, B_fail, LOS_F] where: A_fail = LOS_A or [FOS_A and (not LOS_F)], B_fail = LOS_B or [FOS_B and (not LOS_F)]
- When entering the DH_ACTIV state, the previously asserted A_ACTIV, B_ACTIV, or F_ACTIV flag remains asserted.

Figure 11. Si5364 State Diagram for Input Switching

2.5.4. Manual Switching

Manual switching is selected when the AUTOSEL input is low and is controlled by the MANCTRL[1:0] inputs. When these inputs are set to manually select an input reference, the DSPLL circuitry locks to the selected clock. If the selected input is in a LOS alarm state, the PLL goes into digital hold mode. FOS alarms are declared according to device specifications but have no automatic effect on clock selection in manual mode. The MANCTRL inputs are ignored when the AUTOSEL input is high.

2.5.5. Digital Hold of the PLL

In digital hold mode, the Si5364 digitally holds the internal oscillator at its last frequency value to provide a stable clock output frequency until an input clock is again valid. The clock maintains very stable operation in the presence of constant voltage and temperature. The

frequency accuracy specifications for digital hold mode are given in Table 4 on page 9.

2.5.6. Hitless Recovery from Digital Hold in Manual Switching Mode

When operating in manual switching mode with the Si5364 locked to the selected input clock signal, a loss of the input clock causes the device to automatically switch to digital hold mode. If the MANCTRL[1:0] pins remain stable (the lost clock is still selected), when the input clock signal returns, the device performs a hitless transition from digital hold mode back to the selected input clock. That is, the device performs “phase build-out” to absorb the phase difference between the internal VCO clock operating in digital hold mode and the new/returned input clock.

The hitless recovery feature can be disabled by asserting the FXDDELAY pin. When the FXDDELAY pin is high, the output clock is phase and frequency locked with a fixed-phase relationship to the input clock. Consequently, abrupt phase changes on the input clock will propagate through the device and cause the output to slew at the selected loop bandwidth until the original phase relationship is restored.

2.5.7. Clock Input to Clock Output Delay Adjustment

The INCDELAY and DECDELAY pins adjust the phase of the Si5364 clock outputs. Adjustment is accomplished by driving a pulse (a transition from low to high and then back to low) into one of these pins as the other pin is held at a logic low level.

Each pulse on the INCDELAY pin adds a fixed delay to the Si5364’s clock outputs. The amount of delay time is equal to twice the period of the 622 MHz output clock ($t_{DELAY} = 2/f_{O_622}$).

Each pulse on the DECDELAY pin removes a fixed amount of delay from the Si5364’s clock outputs. The fixed delay time is equal to twice the period of the 622 MHz output clock ($t_{DELAY} = 2/f_{O_622}$).

The frequency of the 622 MHz output clock (f_{O_622}) is nominally 32x the frequency of the input clock. The frequency of the 622 MHz output clock (f_{O_622}) is scaled according to the setting of the FEC[1:0] pins.

When the phase of the Si5364 clock outputs is adjusted using the INCDELAY and/or DECDELAY pins, the output clock moves to its new phase setting at a rate of change that is determined by the setting of the BWSEL[1:0] pins.

Note: INCDELAY and DECDELAY are ignored when the Si5364 operates in digital hold (DH) mode.

2.6. 8 kHz Frame Sync

The Si5364 FSYNC output provides a sync pulse output stream at an 8 kHz nominal rate. The frequency is derived by dividing down the VCO clock output frequency. The FSYNC output pulse stream is time aligned by providing a rising edge on the SYNCIN input pin. See Figure 3 on page 6. The FSYNC output is disabled when 255/238 FEC scaling of the clock output frequencies is selected or when the DSBLFSYNC input is active.

2.7. Reset

The Si5364 provides a Reset/Calibration pin, RSTN/CAL, which resets the device and disables the outputs. When the RSTN/CAL pin is driven low, the internal circuitry enters into the reset mode, and all LVTTTL outputs are forced into a high impedance state. Also, the CLKOUT_n+ and CLKOUT_n- pins are forced to a nominal CML logic LOW and HIGH respectively (See Figure 12). The FRQSEL_n[1:0] setting must be set to 01, 10, or 11 to enable this mode. This feature is useful for in-circuit test applications. A low-to-high transition on RSTN/CAL initializes all digital logic to a known condition and initiates self-calibration of the DSPLL. At the completion of self-calibration, the DSPLL begins to lock to the clock input signal.

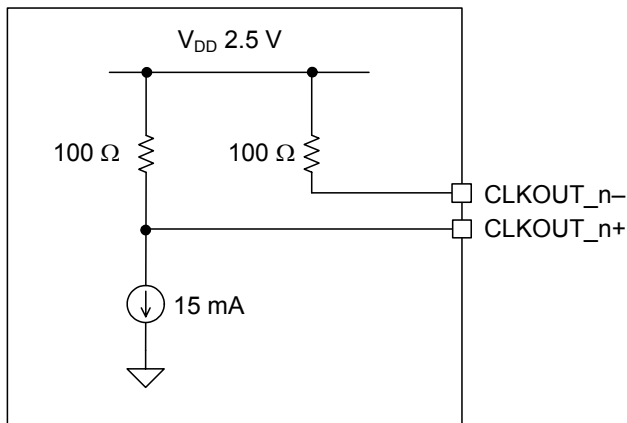

Figure 12. CLKOUT_n± Equivalent Circuit, RSTN/CAL asserted LOW

2.8. PLL Self-Calibration

The Si5364 achieves optimal jitter performance by using self-calibration circuitry to set the VCO center frequency and loop gain parameters within the DSPLL. Internal circuitry generates self calibration automatically on powerup or after a loss-of-power condition. Self-calibration can also be manually initiated by a low-to-

high transition on the RSTN/CAL input.

Self-calibration should be manually initiated after changing the state of the FEC[1:0] inputs. Whether manually initiated or automatically initiated at powerup, the self-calibration process requires the presence of a valid input clock.

If the self-calibration is initiated without a valid clock present, the device waits for a valid clock before completing the self-calibration. The Si5364 clock output is set to the lower end of the operating frequency range while the device waits for a valid clock. After the clock input is validated, the calibration process runs to completion, the device locks to the clock input, and the clock output shifts to its target frequency. Subsequent losses of the input clock signal do not require re-calibration. If the clock input is lost following self-calibration, the device enters digital hold mode. When the input clock returns, the device re-locks to the input clock without performing a self-calibration. During the calibration process, the output clock frequency is indeterminate and may jump as high as 5% above the final locked value.

2.9. Bias Generation Circuitry

The Si5364 uses an external resistor to set internal bias currents. The external resistor generates precise bias currents that significantly reduce power consumption and variation compared with traditional implementations that use an internal resistor. The bias generation circuitry requires a 10 kΩ (1%) resistor connected between REXT and GND.

2.10. Differential Input Circuitry

The Si5364 provides differential inputs for the CLKIN_A, CLKIN_B, and REF/CLKIN_F clock inputs. These inputs are internally biased to a voltage of V_{ICM} (see Table 2 on page 7) and are driven by differential or single-ended driver circuits. The termination resistor is connected externally as shown.

2.11. Differential Output Circuitry

The Si5364 uses current mode logic (CML) output drivers to provide the clock outputs CLKOUT[3:0]. For single-ended operation, leave one CLKOUT line unconnected.

2.12. Power Supply Connections

The Si5364 incorporates an on-chip voltage regulator. The voltage regulator requires an external compensation circuit of one resistor and one capacitor to ensure stability in all operating conditions. Internally, the Si5364 V_{DD33} pins are connected to the on-chip voltage regulator input, and the V_{DD33} pins also supply power to the device's LVTTTL I/O circuitry. The V_{DD25} pins supply power to the core DSPLL circuitry

and are also used for connection of the external compensation circuit.

The compensation circuit for the internal voltage regulator consists of a resistor and a capacitor in series between the V_{DD25} node and ground. In practice, if a capacitor is selected with an appropriate equivalent series resistance (ESR), the discrete series resistor can be eliminated. The target RC time constant for this combination is 15 to 50 μs . The capacitor used in the Si5364 evaluation board is a 33 μF tantalum capacitor with an ESR of 0.8 Ω . This gives an RC time constant of 26.4 μs and no discrete resistor is required. (See Figure 7 on page 14.) The Venkel part number, TA6R3TCR336KBR, is an example of a capacitor that meets these specifications.

To get optimal performance from the Si5364 device, the power supply noise spectrum must comply with the plot in Figure 13. This plot shows the power supply noise tolerance mask for the Si5364. The customer should provide a 3.3 V supply that does not have noise density in excess of the amount shown in the diagram.

However, the diagram cannot be used as spur criteria for a power supply that contains single tone noise.

2.13. Design and Layout Guidelines

Precision clock circuits are susceptible to board noise and EMI. To take precautions against unacceptable levels of board noise and EMI affecting performance of the Si5364, consider the following:

- Use an isolated, local plane to connect the V_{DD25} pins. Avoid running signal traces over or below this plane without a ground plane in between.
- Route all I/O traces between ground planes as much as possible
- Maintain an input clock amplitude in the 200 mV_{PP} to 500 mV_{PP} differential range.

Excessive high-frequency harmonics of the input clock should be minimized. The use of filters on the input clock signal can be used to remove high-frequency harmonics.

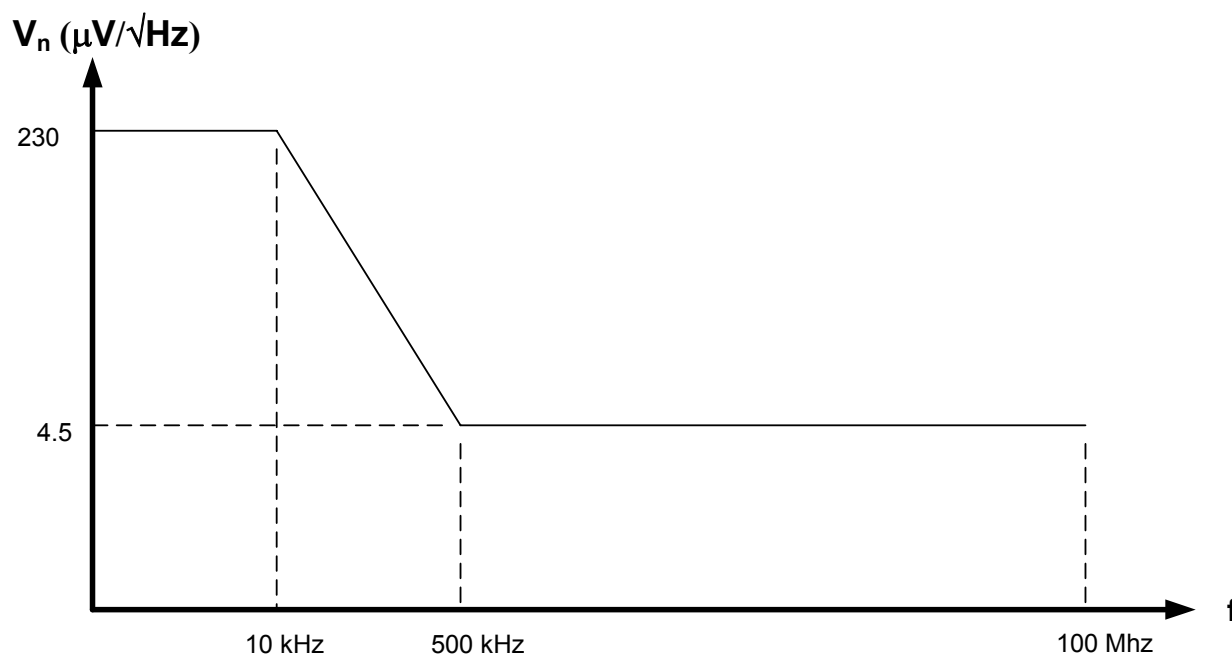

Figure 13. Power Supply Noise Tolerance Mask

3. Pin Descriptions: Si5364

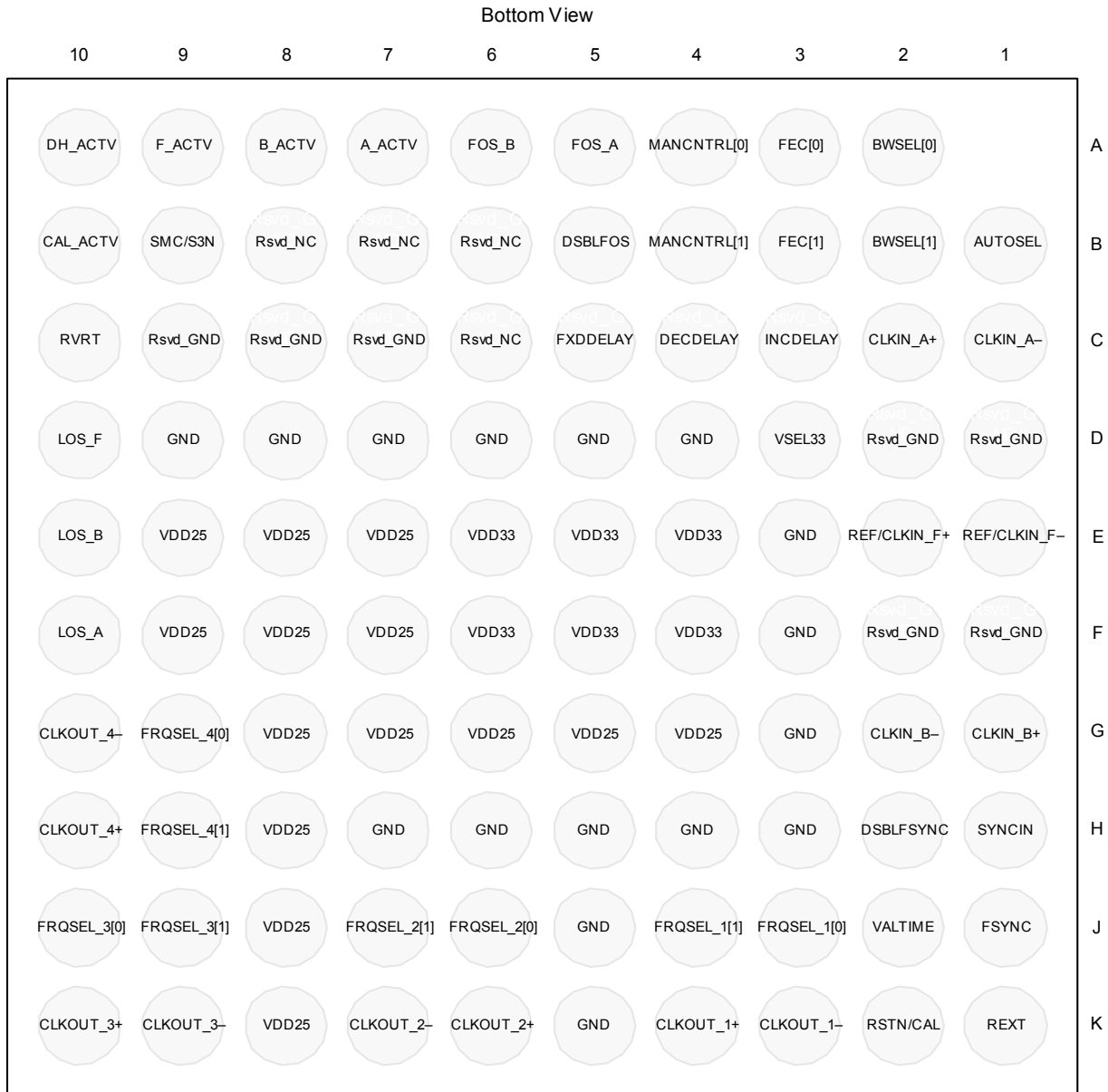

Figure 14. Si5364 Pin Configuration (Bottom View)

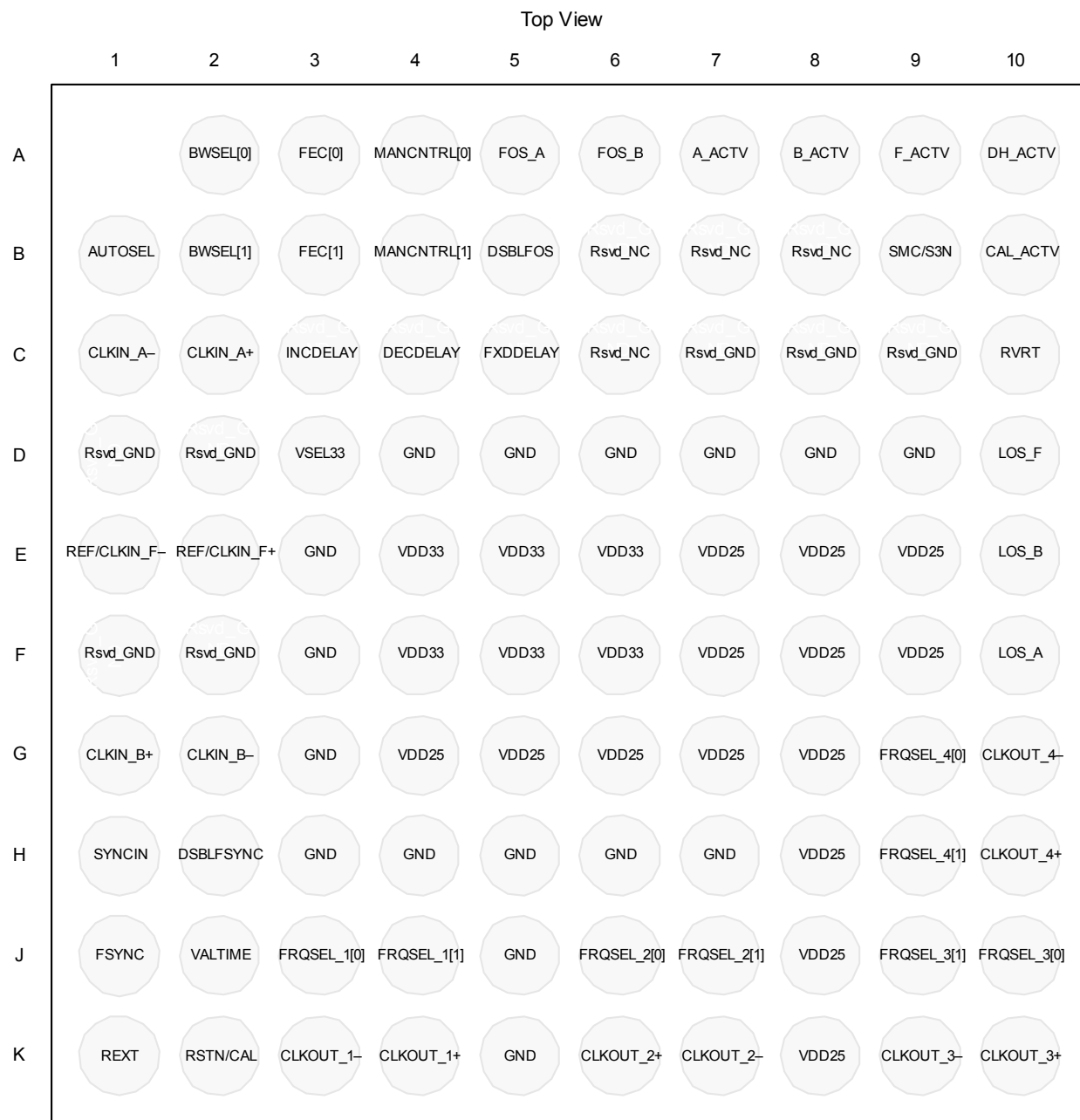

Figure 15. Si5364 Pin Configuration (Transparent Top View)

Table 10. Pin Descriptions

Pin #	Pin Name	I/O	Signal Level	Description
C2 C1	CLKIN_A+ CLKIN_A-	I*	AC Coupled 200–500 mV _{PPD} (See Table 2)	<p>System Clock Input A.</p> <p>One of three differential clock inputs selected by the DSPLL when generating the SONET/SDH compliant clock outputs. The frequencies of the Si5364 clock outputs are each a 1, 8, or 32x multiple of the frequency of the selected clock input. The multiplication ratio is selected using Frequency Select (FRQSEL) control pins associated with each clock output. An additional scaling factor of either 238/255 or 255/238 is selected for FEC operation using the FEC[1:0] control pins.</p> <p>The clock input frequency is nominally 19.44 MHz. The clock input frequency can be varied over the range indicated in Table 3 on page 8 to produce other output frequencies.</p> <p>CLKIN_A is the highest priority clock input during automatic switching mode operation.</p>
G1 G2	CLKIN_B+ CLKIN_B-	I*	AC Coupled 200–500 mV _{PPD} (See Table 2)	<p>System Clock Input B.</p> <p>One of three differential clock inputs selected by the DSPLL when generating the SONET/SDH compliant clock outputs. The frequencies of the Si5364 clock outputs are each a 1, 8, or 32x multiple of the frequency of the selected clock input. The multiplication ratio is selected using Frequency Select (FRQSEL) control pins associated with each clock output. An additional scaling factor of either 238/255 or 255/238 can be selected for FEC operation using the FEC[1:0] control pins.</p> <p>The clock input frequency is nominally 19.44 MHz. and can be varied over the range indicated in Table 3 on page 8 to produce other output frequencies.</p> <p>CLKIN_B is the second highest priority clock input during automatic switching mode operation.</p>
<p>*Note: The LVTTTL inputs on the Si5364 device have an internal pulldown mechanism that causes the input to default to a logic low state if the input is not driven from an external source.</p>				

Table 10. Pin Descriptions (Continued)

Pin #	Pin Name	I/O	Signal Level	Description
E2 E1	REF/CLKIN_F+ REF/CLKIN_F-	I*	AC Coupled 200–500 mV _{PPD} (See Table 2)	<p>Frequency Reference/Backup Clock Input.</p> <p>Used by the DSPLL as a frequency reference for determining the frequency accuracy of the CLKIN_A and CLKIN_B inputs. If the frequency offset of either the CLKIN_A or the CLKIN_B inputs relative to REF/CLKIN_F exceeds the selected frequency offset threshold, the corresponding Frequency Offset error flag (FOS_A or FOS_B) is asserted. The frequency offset threshold is selected with the SMC/S3N input. In automatic switching mode, Frequency Offset errors can cause switching of the input clock selection. (See AUTOSEL pin description.) If the REF/CLKIN_F signal is not present, the FOS_A and FOS_B error flags are generated, along with the LOS_F Loss-of-Signal error flag. The FOS_A and FOS_B error flags are ignored for the purposes of automatic switching in the presence of the LOS_F flag.</p> <p>The REF/CLKIN_F input can also be utilized as a third clock input that can be selected by the DSPLL in the generation of the SONET/SDH compliant clock outputs. When REF/CLKIN_F is input to the DSPLL rather than as a frequency accuracy reference for CLKIN_A and CLKIN_B, the FOS_A or FOS_B frequency offset error outputs can be disabled with the DSBLFOS control input.</p> <p>The frequencies of the Si5364 clock outputs are each a 1, 8, or 32x multiple of the frequency of the selected clock input. The multiplication ratio is selected using Frequency Select (FRQSEL) control pins associated with each clock output. An additional scaling factor of either 238/255 or 255/238 can be selected for FEC operation using the FEC[1:0] control pins.</p> <p>The clock input frequency is nominally 19.44 MHz. Clock input frequency can be varied over the range indicated in Table 3 on page 8 to produce other output frequencies.</p>
F10	LOS_A	O	LVTTL	<p>Loss-of-Signal (LOS) Alarm for CLKIN_A.</p> <p>Indicates that the Si5364 detects a missing pulse on the CLKIN_A clock input signal. The LOS alarm is cleared after either 100 ms or 13 s of valid CLKIN_A clock input signal, depending on the setting of the VALTIME control input.</p>
E10	LOS_B	O	LVTTL	<p>Loss-of-Signal (LOS) Alarm for CLKIN_B.</p> <p>See LOS_A.</p>
<p>*Note: The LVTTL inputs on the Si5364 device have an internal pulldown mechanism that causes the input to default to a logic low state if the input is not driven from an external source.</p>				

Table 10. Pin Descriptions (Continued)

Pin #	Pin Name	I/O	Signal Level	Description
D10	LOS_F	O	LVTTL	Loss-of-Signal (LOS) Alarm for REF/CLKIN_F. See LOS_A.
A5	FOS_A	O	LVTTL	Frequency Offset (FOS) Alarm for CLKIN_A. Active high output indicates that the frequency offset between CLKIN_A and REF/CLKIN_F exceeds the selectable frequency offset threshold. The offset threshold is selected by the SMC/S3N input. This output can be disabled with the DSBLFOS control input.
A6	FOS_B	O	LVTTL	Frequency Offset (FOS) Alarm for CLKIN_B. See FOS_A.
B9	SMC/S3N	I*	LVTTL	SONET Minimum Clock/Stratum3-3E. Sets the frequency offset threshold used to trigger the FOS_A and FOS_B alarm outputs. 0 = 9.2–16.6 ppm for Stratum 3/3E operation. 1 = 40–72 ppm for SONET Minimum Clock operation.
B5	DSBLFOS	I*	LVTTL	Disable FOS. When high, all frequency offset comparison and error generation functionality is disabled. When Disable FOS is active, the FOS_A and FOS_B outputs are low, and automatic switching is based only on loss-of-signal (LOS) status.
A4 B4	MANCNTRL[0] MANCNTRL[1]	I*	LVTTL	Manual Switching Control. Selects the input clock used by the DSPLL to generate the SONET/SDH clock outputs. Selection of digital hold mode locks the current state of the DSPLL and forces the DSPLL to continue generation of the output clocks with no additional phase or frequency information from the input clocks. The MANCNTRL inputs are internally deglitched to prevent inadvertent clock switching during changes in the MANCNTRL state. The MANCNTRL[1:0] inputs are decoded as follows: 00 = Manual selection of REF/CLKIN_F. 01 = Manual selection of CLKIN_B. 10 = Manual selection of CLKIN_A. 11 = Digital hold mode. The MANCNTRL inputs are ignored when the AUTOSEL input is high.
*Note: The LVTTL inputs on the Si5364 device have an internal pulldown mechanism that causes the input to default to a logic low state if the input is not driven from an external source.				

Table 10. Pin Descriptions (Continued)

Pin #	Pin Name	I/O	Signal Level	Description
B1	AUTOSEL	I*	LVTTL	<p>Automatic Switching Mode Select.</p> <p>When 1, the clock input used by the DSPLL to generate the SONET/SDH clock outputs is selected automatically. The automatic switching mode initially selects the highest priority clock available, with the priorities indicated below:</p> <p>CLKIN_A: Highest Priority CLKIN_B: Second Highest Priority REF/CLKIN_F: Lowest Priority</p> <p>If the selected input clock fails because of an LOS or FOS alarm condition, the next lower priority clock that is available is selected.</p> <p>If an input clock that has a higher priority than the currently-selected clock becomes available, the higher priority clock is selected only if RVRT is active. If RVRT is not active, automatic switching to a higher priority clock is disabled.</p>
A7	A_ACTV	O	LVTTL	<p>CLKIN_A is Active.</p> <p>Active high output indicates that CLKIN_A is selected as the clock input to the DSPLL.</p> <p>The DH_ACTV output takes precedence over this signal as an indicator of the DSPLL clock input status. When this output is high and the DH_ACTV output is low, CLKIN_A is being used by the DSPLL to generate the SONET/SDH compatible output clocks. When this output is high and the DH_ACTV output is high, CLKIN_A is selected, but the DSPLL is in digital hold mode. See DH_ACTV.</p>
A8	B_ACTV	O	LVTTL	<p>CLKIN_B is Active.</p> <p>Active high output indicates that CLKIN_B is selected as the clock input to the DSPLL.</p> <p>The DH_ACTV output takes precedence over this signal as an indicator of the DSPLL clock input status. When this output is high and the DH_ACTV output is low, CLKIN_B is being used by the DSPLL to generate the SONET/SDH compatible output clocks. When this output is high and the DH_ACTV output is high, CLKIN_B is selected, but the DSPLL is in digital hold mode. See DH_ACTV.</p>
<p>*Note: The LVTTL inputs on the Si5364 device have an internal pulldown mechanism that causes the input to default to a logic low state if the input is not driven from an external source.</p>				

Table 10. Pin Descriptions (Continued)

Pin #	Pin Name	I/O	Signal Level	Description
A9	F_ACTV	O	LVTTL	REF/CLKIN_F is Active. Active high output indicates that REF/CLKIN_F is selected as the clock input to the DSPLL. The DH_ACTV output takes precedence over this signal as an indicator of the DSPLL clock input status. When this output is high and the DH_ACTV output is low, REF/CLKIN_F is being used by the DSPLL to generate the SONET/SDH compatible output clocks. When this output is high and the DH_ACTV output is high, REF/CLKIN_F is selected, but the DSPLL is in digital hold mode. Refer to DH_ACTV.
A10	DH_ACTV	O	LVTTL	Digital Hold Mode Active. Active high output indicates that the DSPLL is in digital hold mode. Digital hold mode locks the current state of the DSPLL and forces the DSPLL to continue generation of the output clocks with no additional phase or frequency information from the input clocks.
C10	RVRT	I*	LVTTL	Revertive Switching. Selects the revertive switching mode during automatic switching operation. If this input is high during automatic switching, the revertive switching mode is selected. The highest priority reference source that is valid is selected as the DSPLL reference source. See AUTOSEL pin description. During manual mode of operation, this input has no effect.
K2	RSTN/CAL	I*	LVTTL	Reset/Calibrate. When low, the internal circuitry enters the reset mode and all LVTTL outputs are forced into a high-impedance state. Also, the CLKOUT_n+ and CLKOUT_n- pins are forced to a nominal CML logic LOW and HIGH respectively. The FRQSEL_n[1:0] setting must be set to 01, 10, or 11 to enable this mode. This mode is useful for in-circuit test applications. A low-to-high transition on RSTN/CAL initializes all digital logic to a known condition, enables the device outputs, and initiates self-calibration of the DSPLL. At the completion of self-calibration, the DSPLL begins to lock to the selected clock input signal.

***Note:** The LVTTL inputs on the Si5364 device have an internal pulldown mechanism that causes the input to default to a logic low state if the input is not driven from an external source.

Table 10. Pin Descriptions (Continued)

Pin #	Pin Name	I/O	Signal Level	Description
K4 K3	CLKOUT_1+ CLKOUT_1-	O	CML	Differential Clock Output 1. High-frequency output clock derived from the selected reference source (CLKIN_A, CLKIN_B, or REF/CLKIN_F) or from Digital hold mode. The frequencies of the Si5364 clock outputs are each 1, 8, or 32x multiple of the frequency of the selected clock input. The multiplication ratio is selected using Frequency Select (FRQSEL) control pins associated with each clock output. An additional scaling factor of either 238/255 or 255/238 can be selected for FEC operation using the FEC[1:0] control pins.
K6 K7	CLKOUT_2+ CLKOUT_2-	O	CML	Differential Clock Output 2. See CLKOUT_1.
K10 K9	CLKOUT_3+ CLKOUT_3-	O	CML	Differential Clock Output 3. See CLKOUT_1.
H10 G10	CLKOUT_4+ CLKOUT_4-	O	CML	Clock Output 4. See CLKOUT_1.
J3 J4	FRQSEL_1[0] FRQSEL_1[1]	I*	LVTTL	Frequency Select—Clock Out 1. Selects the multiplication factor between the frequency of the selected clock input and the frequency of the clock output. The FRQSEL_1[1:0] inputs are decoded as follows: 00 = Clock Driver Power Down. 01 = 1x multiplication (19.44 MHz output typical). 10 = 8x multiplication (155.52 MHz output typical). 11 = 32x multiplication (622.08 MHz output typical). The clock output multiplication ratios can be scaled additionally by a factor of 255/238 or 238/255 for FEC operation. See FEC[1:0] pin description.
J6 J7	FRQSEL_2[0] FRQSEL_2[1]	I*	LVTTL	Frequency Select—Clock Out 2. See FRQSEL_1[1:0].
J10 J9	FRQSEL_3[0] FRQSEL_3[1]	I*	LVTTL	Frequency Select—Clock Out 3. See FRQSEL_1[1:0].
G9 H9	FRQSEL_4[0] FRQSEL_4[1]	I*	LVTTL	Frequency Select—Clock Out 4. See FRQSEL_1[1:0].
J1	FSYNC	O	See Table 3	Frame Sync Clock. Nominally 8 kHz based on a 19.44 MHz reference. The 8 kHz frame sync is disabled when 255/238 FEC scaling of the clock output frequencies is selected. See FEC[1:0] pin description.

***Note:** The LVTTL inputs on the Si5364 device have an internal pulldown mechanism that causes the input to default to a logic low state if the input is not driven from an external source.

Table 10. Pin Descriptions (Continued)

Pin #	Pin Name	I/O	Signal Level	Description
H1	SYNCIN	I*	LVTTL	Synchronization Input for Frame Sync Clock. Allows time alignment/realignment of the FSYNC output clock. A rising edge on the SYNCIN input forces alignment of the FSYNC output clock stream.
H2	DSBLFSYNC	I*	LVTTL	Disable the FSYNC Clock Output. When high, the output driver for the FSYNC pin is disabled.
A3 B3	FEC[0] FEC[1]	I*	LVTTL	Forward Error Correction (FEC) Selection. Enable or disable scaling of the input-to-output frequency multiplication factor for FEC clock rate compatibility. The multiplication ratios and associated frequency ranges for the Si5364 clock outputs are set by the FRQSEL pins associated with each clock output. Additional scaling by a factor of either 255/238 or 238/255 can be applied to all active outputs as indicated below. The FEC[1:0] inputs are decoded as follows: 00 = No FEC scaling, FSYNC enabled. 01 = 255/238 FEC scaling for all clock outputs, FSYNC disabled. 10 = 238/255 FEC scaling for all clock inputs, FSYNC enabled. 11 = Reserved. The FSYNC output is disabled when FEC[1:0] = 01.
A2 B2	BWSEL[0] BWSEL[1]	I*	LVTTL	Bandwidth Select. The BWSEL[1:0] pins set the bandwidth of the loop filter within the DSPLL to 3200 Hz, 800 Hz, or 6400 Hz as indicated below. 00 = 3200 Hz 01 = 1600 Hz 10 = 800 Hz 11 = 6400 Hz
B10	CAL_ACTV	O	LVTTL	Calibration Mode Active. Is driven high during the DSPLL self-calibration and the subsequent initial lock acquisition period.
C7–9, D1–2, F1–2	Rsvd_GND	—	LVTTL	Reserved—Tie to Ground. Must be tied to GND for normal operation.
B6–8, C6	Rsvd_NC	—	LVTTL	Reserved—No Connect. Must be left unconnected for normal operation.
*Note: The LVTTL inputs on the Si5364 device have an internal pulldown mechanism that causes the input to default to a logic low state if the input is not driven from an external source.				

Table 10. Pin Descriptions (Continued)

Pin #	Pin Name	I/O	Signal Level	Description
J2	VALTIME	I*	LVTTL	Clock Validation Time for LOS and FOS. VALTIME sets the clock validation times for recovery from an LOS or FOS alarm condition. When VALTIME is high, the validation time is approximately 13 s. When VALTIME is low, the validation time is approximately 100 ms.
D3	VSEL33	I*	LVTTL	Select 3.3 V V_{DD} Supply. This is an enable pin for the internal regulator. To enable the regulator, connect this pin to the V _{DD33} pins.
E4–6, F4–6	V _{DD33}	V _{DD}	Supply	3.3 V Supply. 3.3 V power is applied to the V _{DD33} pins. Typical supply bypassing/decoupling for this configuration is indicated in the typical application diagram for 3.3 V supply operation.
E7–9, F7–9, G4–8, H8, J8, K8	V _{DD25}	V _{DD}	Supply	2.5 V Supply. These pins provide a means of connecting the compensation network for the on-chip regulator.
D4–9, E3, F3, G3, H3– 7, J5, K5	GND	GND	Supply	Ground. Must be connected to system ground. Minimize the ground path impedance for optimal performance of the device.
K1	REXT	I*	Analog	External Biasing Resistor. Establishes bias currents within the device. This pin must be connected to GND through a 10 k Ω (1%) resistor.

***Note:** The LVTTL inputs on the Si5364 device have an internal pulldown mechanism that causes the input to default to a logic low state if the input is not driven from an external source.

Table 10. Pin Descriptions (Continued)

Pin #	Pin Name	I/O	Signal Level	Description
C3	INCDELAY	I*	LVTTL	<p>Increment Output Phase Delay.</p> <p>The INCDELAY and DECDELAY pins can adjust the phase of the Si5364 clock outputs. Adjustment is accomplished by driving a pulse (a transition from low to high and then back to low) into one of the pins while the other pin is held at a logic low level.</p> <p>Each pulse on the INCDELAY pin adds a fixed delay to the Si5364's clock outputs. The fixed delay time is equal to twice the period of the 622 MHz output clock ($t_{\text{DELAY}} = 2/f_{o_622}$). The frequency of the 622 MHz output clock (f_{o_622}) is nominally 32x the frequency of the input clock. The frequency of the 622 MHz output clock (f_{o_622}) is scaled additionally according to the setting of the FEC[1:0] pins.</p> <p>When the phase of the Si5364 clock outputs is adjusted using the INCDELAY and/or DECDELAY pins, the output clock moves to its new phase setting at a rate of change that is determined by the setting of the BWSEL[1:0] pins.</p> <p>Note: INCDELAY is ignored when the Si5364 is operating in digital hold (DH) mode.</p>
C4	DECDELAY	I*	LVTTL	<p>Decrement Output Phase Delay.</p> <p>The INCDELAY and DECDELAY pins can adjust the phase of the Si5364 clock outputs. Adjustment is accomplished by driving a pulse (a transition from low to high and then back to low) into one of the pins while the other pin is held at a logic low level.</p> <p>Each pulse on the DECDELAY pin removes a fixed delay from the Si5364's clock outputs. The fixed delay time is equal to twice the period of the 622 MHz output clock ($t_{\text{DELAY}} = 2/f_{o_622}$). The frequency of the 622 MHz output clock (f_{o_622}) is nominally 32x the frequency of the input clock. The frequency of the 622 MHz output clock (f_{o_622}) is scaled additionally according to the setting of the FEC[1:0] pins.</p> <p>When the phase of the Si5364 clock outputs is adjusted using the INCDELAY and/or DECDELAY pins, the output clock moves to its new phase setting at a rate of change that is determined by the setting of the BWSEL[1:0] pins.</p> <p>Note: INCDELAY is ignored when the Si5364 is operating in digital hold (DH) mode.</p>

***Note:** The LVTTL inputs on the Si5364 device have an internal pulldown mechanism that causes the input to default to a logic low state if the input is not driven from an external source.

Table 10. Pin Descriptions (Continued)

Pin #	Pin Name	I/O	Signal Level	Description
C5	FXDDELAY	I*	LVTTL	<p>Fixed Delay Control.</p> <p>Active high input that fixes the clock input to clock output phase relationship to a constant value. When this pin is high and the device is operating in manual select mode (AUTOSEL = 0), hitless recovery from digital hold is disabled, and the input to output phase relationship will remain fixed as long as the MANCNTRL[1:0] pins remain unchanged.</p> <p>This feature is useful in applications that utilize a single clock source and require a known input-to-output phase relationship. The FXDDELAY input is ignored when AUTOSEL is high.</p>
<p>*Note: The LVTTL inputs on the Si5364 device have an internal pulldown mechanism that causes the input to default to a logic low state if the input is not driven from an external source.</p>				

Si5364

4. Ordering Guide

Part Number	Package	Temperature Range
Si5364-G-BC	99-Ball CBGA (Prior Revision) RoHS-5	-20 to 85 °C
Si5364-H-BL	99-Ball PBGA (Current Revision) RoHS-5	-20 to 85 °C
Si5364-H-GL	99-Ball PBGA (Current Revision) RoHS-6	-20 to 85 °C

5. Package Outline

Figure 16 illustrates the package details for the Si5364. Table 11 lists the values for the dimensions shown in the illustration.

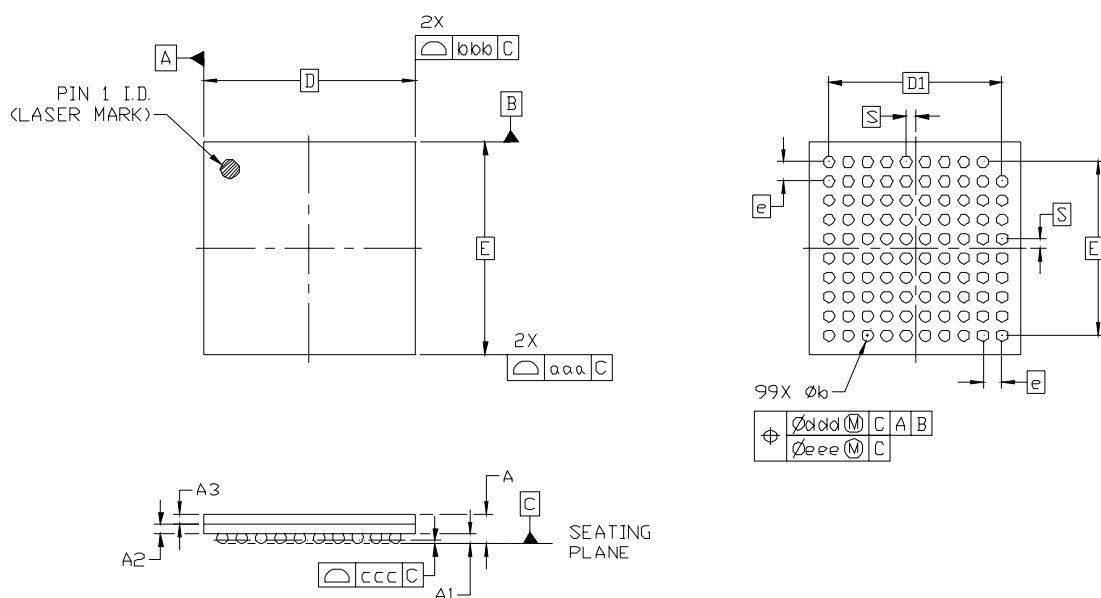

Figure 16. 99-Ball Plastic Ball Grid Array (PBGA)

Table 11. Package Diagram Dimensions (mm)

Symbol	Min	Nom	Max
A	1.35	1.52	1.69
A1	0.40	0.50	0.60
A2	0.45	0.49	0.53
A3	0.50	0.53	0.56
b	0.50	0.60	0.70
D	11.00 BSC		
E	11.00 BSC		
D1	9.00 BSC		

Symbol	Min	Nom	Max
E1	9.00 BSC		
e	1.00 BSC		
S	0.50 BSC		
aaa	0.10		
bbb	0.10		
ccc	0.12		
ddd	0.15		
eee	0.08		

Notes:

1. All dimensions shown are in millimeters (mm) unless otherwise noted.
2. Dimensioning and Tolerancing per ANSI Y14.5M-1994.
3. This drawing conforms to JEDEC outline MO-192, variation AAC-1.
4. Recommended card reflow profile is per the JEDEC/IPC J-STD-020C specification for Small Body Components.

6. 11x11 mm PBGA Card Layout

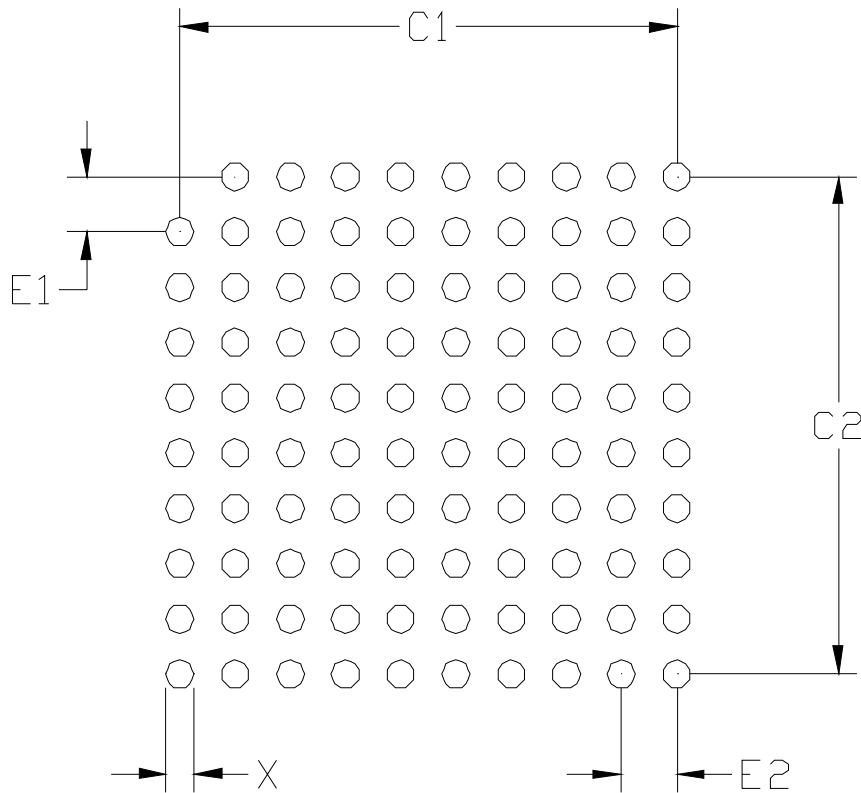

Symbol	Min	Nom	Max
X	0.40	0.45	0.50
C1	9.00		
C2	9.00		
E1	1.00		
E2	1.00		

Notes:

General

1. All dimensions shown are in millimeters (mm) unless otherwise noted.
2. Dimensioning and Tolerancing is per the ANSI Y14.5M-1994 specification.
3. This Land Pattern Design is based on the IPC-7351 guidelines.

Solder Mask Design

1. All metal pads are to be non-solder mask defined (NSMD). Clearance between the solder mask and the metal pad is to be 60 μm minimum, all the way around the pad.

Stencil Design

1. A stainless steel, laser-cut and electro-polished stencil with trapezoidal walls should be used to assure good solder paste release.
2. The stencil thickness should be 0.125 mm (5 mils).
3. The ratio of stencil aperture to land pad size should be 1:1.

Card Assembly

1. A No-Clean, Type-3 solder paste is recommended.
2. The recommended card reflow profile is per the JEDEC/IPC J-STD-020C specification for Small Body Components.

DOCUMENT CHANGE LIST

Revision 2.0 to Revision 2.1

- Update Table 3, "AC Characteristics," on page 8.
- Updated Figure 10, "Phase Transient Specification," on page 18.
- Updated Table 11, "Package Diagram Dimensions (mm)," on page 35.
- Added Figure 6, "Typical Si5364 Phase Noise (CLKIN = 19.44 MHz, CLKOUT = 622.08 MHz, and Loop BW = 800 Hz)," on page 13.

Revision 2.1 to Revision 2.2

- Updated "2.7. Reset" on page 20.
- Updated Table 11, "Package Diagram Dimensions (mm)," on page 35.

Revision 2.2 to Revision 2.3

- Updated "5. Package Outline" on page 35.

Revision 2.3 to Revision 2.4

- Updated "4. Ordering Guide" on page 34.
- Updated "5. Package Outline" on page 35.
- Updated "6. 11x11 mm PBGA Card Layout" on page 36.

Revision 2.4 to Revision 2.5

- Updated Table 6, "Thermal Characteristics," on page 12.

CONTACT INFORMATION

Silicon Laboratories Inc.

400 West Cesar Chavez
Austin, TX 78701
Tel: 1+(512) 416-8500
Fax: 1+(512) 416-9669
Toll Free: 1+(877) 444-3032
Email: Clockinfo@silabs.com
Internet: www.silabs.com

The information in this document is believed to be accurate in all respects at the time of publication but is subject to change without notice. Silicon Laboratories assumes no responsibility for errors and omissions, and disclaims responsibility for any consequences resulting from the use of information included herein. Additionally, Silicon Laboratories assumes no responsibility for the functioning of undescribed features or parameters. Silicon Laboratories reserves the right to make changes without further notice. Silicon Laboratories makes no warranty, representation or guarantee regarding the suitability of its products for any particular purpose, nor does Silicon Laboratories assume any liability arising out of the application or use of any product or circuit, and specifically disclaims any and all liability, including without limitation consequential or incidental damages. Silicon Laboratories products are not designed, intended, or authorized for use in applications intended to support or sustain life, or for any other application in which the failure of the Silicon Laboratories product could create a situation where personal injury or death may occur. Should Buyer purchase or use Silicon Laboratories products for any such unintended or unauthorized application, Buyer shall indemnify and hold Silicon Laboratories harmless against all claims and damages.

Silicon Laboratories, Silicon Labs, and DSPLL are trademarks of Silicon Laboratories Inc.
Other products or brand names mentioned herein are trademarks or registered trademarks of their respective holders.

Looking for pricing, stock, or lifecycle information?

Click below to explore more details on WIN SOURCE:

 [View SI5364-H-BL on WIN SOURCE](#)

 [Silicon Labs](#) Information

Optimize Your Supply Chain with WIN SOURCE Solutions

-  Global Sourcing Solution
-  Obsolete Management
-  Cost Control Management
-  Shortage Management
-  Alternative Solution
-  Excess Inventory Management