



**THE DATASHEET OF
74ALVCHS162830DGB;**



DATA SHEET

74ALVCHS162830

18-bit to 36-bit address driver
with bus hold (3-State)

Product data

2001 Sep 07

File under Integrated Circuits — ICL03

18-bit to 36-bit address driver with bus hold (3-State) 74ALVCHS162830

FEATURES

- Output ports have equivalent 26 Ω series resistors, so no external resistors are required
- Diodes on inputs clamp overshoot
- ESD classification testing is done to JEDEC Standard JESD22. Protection exceeds 2000 V HBM per method A114.
- Latch-up testing is done to JEDEC Standard JESD78, which exceeds 100 mA.
- Bus hold on data inputs eliminates the need for external pullup/pulldown resistors
- Packaged in thin very small-outline package (TVSOP) — 0.4 mm pitch
- Optimized for use with PCK953 in SDRAM module applications
- Balanced ±12 mA output drive
- Low noise, low skew

DESCRIPTION

The ALVCHS162830 address driver is designed for 2.3 V to 3.6 V V_{CC} operation.

Diodes to V_{CC} have been added on the inputs to clamp overshoot.

The bus hold feature retains the inputs' last state whenever the input bus goes to high impedance. This prevents floating inputs and eliminates the need for pull up or pull down resistors.

The outputs, which are designed to sink up to 12 mA, include equivalent 26 Ω series resistors to reduce overshoot and undershoot.

To ensure the high-impedance state during power up or power down, the output-enable (OE) input should be tied to V_{CC} through a pullup resistor; the minimum value of the resistor is determined by the current-sinking capability of the driver.

The 74ALVCHS162830 is characterized for operation from -40 to +85 °C.

FUNCTION TABLE

| Inputs | | | Outputs | |
|------------------|------------------|---|---------|-----|
| $\overline{OE1}$ | $\overline{OE2}$ | A | 1Yn | 2Yn |
| L | H | H | H | Z |
| L | H | L | L | Z |
| H | L | H | Z | H |
| H | L | L | Z | L |
| L | L | H | H | H |
| L | L | L | L | L |
| H | H | X | Z | Z |

PIN CONFIGURATION

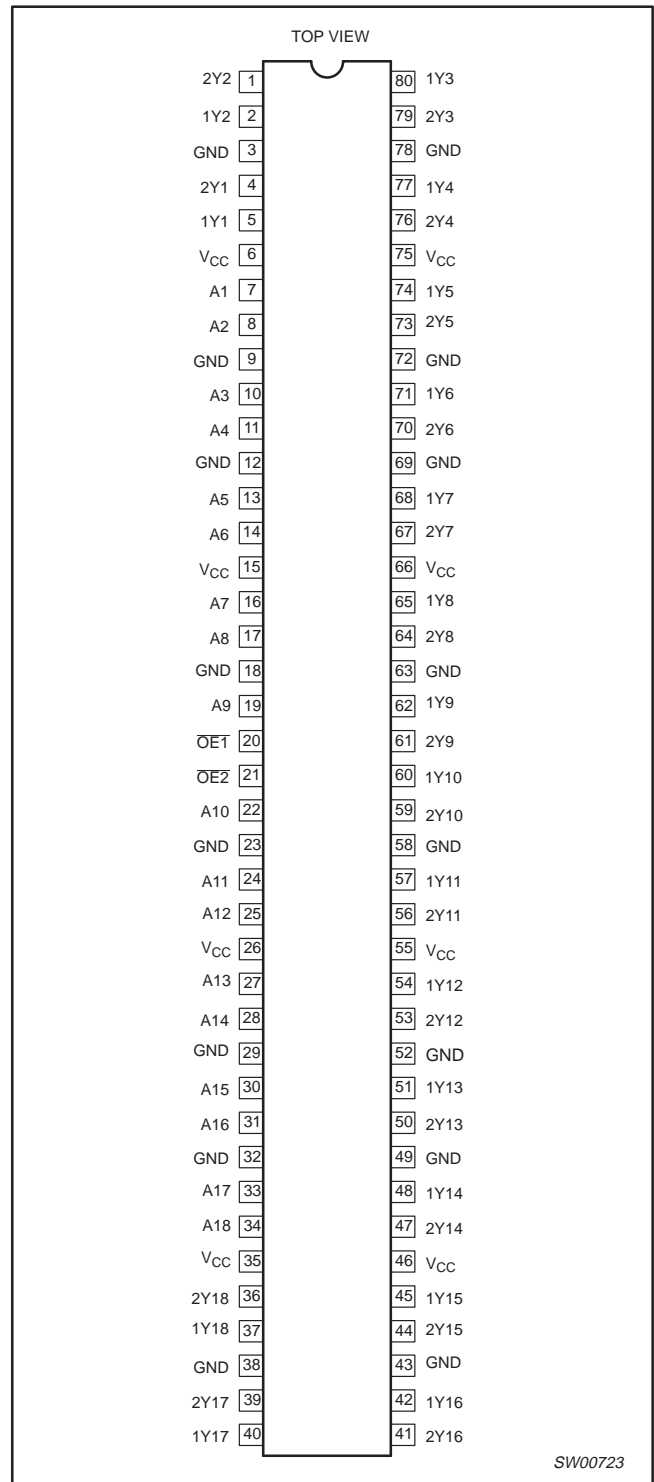

SW00723

ORDERING INFORMATION

| PACKAGES | TEMPERATURE RANGE | ORDER CODE | DWG NUMBER |
|--|-------------------|-------------------|------------|
| 80-pin plastic thin very small outline (TVSOP) | -40 to +85 °C | 74ALVCHS162830DGB | SOT647-1 |

18-bit to 36-bit address driver with bus hold (3-State)

74ALVCHS162830

LOGIC DIAGRAM (POSITIVE LOGIC)

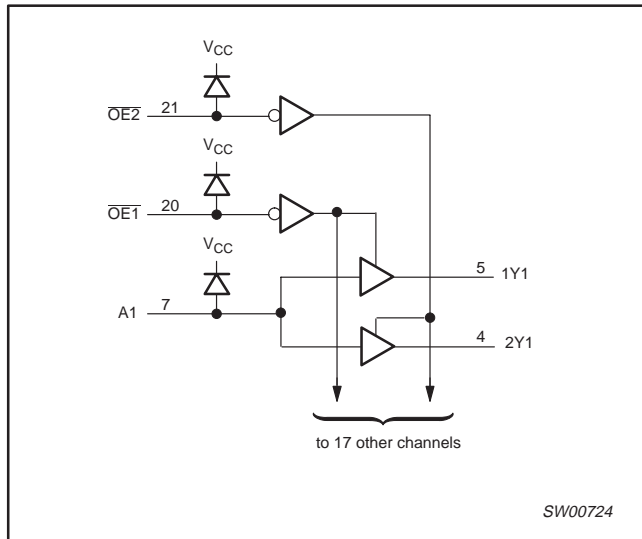

PIN DESCRIPTION

| PIN(S) | SYMBOL | FUNCTION |
|--|-----------------------------------|----------------|
| 6, 15, 26, 35, 46, 55, 66, 75 | V _{CC} | Supply voltage |
| 7, 8, 10, 11, 13, 14, 16, 17, 19, 22, 24, 25, 27, 28, 30, 31, 33, 34 | A _n | Inputs |
| 1, 2, 4, 5, 36, 37, 39, 40, 41, 42, 44, 45, 47, 48, 50, 51, 53, 54, 56, 57, 59, 60, 61, 62, 64, 65, 67, 68, 70, 71, 73, 74, 76, 77, 79, 80 | 1Y _n , 2Y _n | Outputs |
| 20, 21 | OE1, OE2 | Output enable |
| 3, 9, 12, 18, 23, 29, 32, 38, 43, 49, 52, 58, 63, 69, 72, 78 | GND | Ground |

ABSOLUTE MAXIMUM RATINGS

Over recommended operating free-air temperature range (unless otherwise noted).¹

| SYMBOL | PARAMETER | CONDITIONS | RATING | UNIT |
|------------------------------------|--|--------------------|------------------------------|------|
| V _{CC} | Supply voltage range | | -0.5 to +4.6 | V |
| V _I | Input voltage range | See Note 2 | -0.5 to +4.6 | V |
| V _O | Output voltage range | See Notes 2 and 3 | -0.5 to V _{CC} +0.5 | V |
| I _{IK} | Input clamp current | V _I < 0 | -50 | mA |
| I _{OK} | Output clamp current | V _O < 0 | -50 | mA |
| I _O | Continuous output current | | ±50 | mA |
| I _{CC} , I _{GND} | Continuous current through each V _{CC} or GND | | ±100 | mA |
| Θ _{JA} | Package thermal impedance | See Note 4 | 106 | °C/W |
| T _{stg} | Storage temperature range | | -65 to +150 | °C |

NOTES:

- Stresses beyond those listed under "absolute maximum ratings" may cause permanent damage to the device. These are stress ratings only, and functional operation of the device at these or any other conditions beyond those indicated under "recommended operating conditions" is not implied. Exposure to absolute-maximum-rated conditions for extended periods may affect device reliability.
- The input negative-voltage and output voltage ratings may be exceeded if the input and output current ratings are observed.
- This value is limited to 4.6 V maximum.
- The package thermal impedance is calculated in accordance with JESD 51.

18-bit to 36-bit address driver with bus hold (3-State)

74ALVCHS162830

RECOMMENDED OPERATING CONDITIONS

All unused control inputs of the device must be held at V_{CC} or GND to ensure proper device operation.

| SYMBOL | PARAMETER | CONDITIONS | LIMITS | | UNIT |
|---------------------|------------------------------------|--|--------|----------|------|
| | | | MIN | MAX | |
| V_{CC} | Supply voltage | | 2.3 | 3.6 | V |
| V_{IH} | High-level input voltage | $V_{CC} = 2.3 \text{ V to } 2.7 \text{ V}$ | 1.7 | | V |
| | | $V_{CC} = 2.7 \text{ V to } 3.6 \text{ V}$ | 2 | | |
| V_{IL} | Low-level input voltage | $V_{CC} = 2.3 \text{ V to } 2.7 \text{ V}$ | | 0.7 | V |
| | | $V_{CC} = 2.7 \text{ V to } 3.6 \text{ V}$ | | 0.8 | |
| V_I | Input voltage | | 0 | V_{CC} | V |
| V_O | Output voltage | | 0 | V_{CC} | V |
| I_{OH} | High-level output current | $V_{CC} = 2.3 \text{ V}$ | | -6 | mA |
| | | $V_{CC} = 2.7 \text{ V}$ | | -8 | |
| | | $V_{CC} = 3 \text{ V}$ | | -12 | |
| I_{OL} | Low-level output current | $V_{CC} = 2.3 \text{ V}$ | | 6 | mA |
| | | $V_{CC} = 2.7 \text{ V}$ | | 8 | |
| | | $V_{CC} = 3 \text{ V}$ | | 12 | |
| $\Delta t/\Delta v$ | Input transition rise or fall rate | | | 10 | ns/V |
| T_{amb} | Operating free-air temperature | | -40 | +85 | °C |

18-bit to 36-bit address driver with bus hold (3-State)

74ALVCHS162830

ELECTRICAL CHARACTERISTICS

Over recommended operating free-air temperature range (unless otherwise noted).

| SYMBOL | PARAMETER | TEST CONDITIONS | V _{CC} | LIMITS | | | UNIT | |
|----------------------|----------------|---|-------------------------|----------------------|------------------|----------------------|------|------|
| | | | | MIN | TYP ¹ | MAX | | |
| V _{IK} | | I _I = -18 mA | 2.3 V | | | -1.2 | V | |
| | | I _I = 18 mA | 2.3 V | | | V _{CC} +1.2 | | |
| V _{OH} | | I _{OH} = -100 μA | 2.3 V to 3.6 V | V _{CC} -0.2 | | | V | |
| | | I _{OH} = -4 mA, V _{IH} = 1.7 V | 2.3 V | 1.9 | | | | |
| | | I _{OH} = -6 mA | V _{IH} = 1.7 V | 2.3 V | 1.7 | | | |
| | | | V _{IH} = 2 V | 3 V | 2.4 | | | |
| | | I _{OH} = -8 mA, V _{IH} = 2 V | 2.7 V | 2 | | | | |
| | | I _{OH} = -12 mA, V _{IH} = 2 V | 3 V | 2 | | | | |
| V _{OL} | | I _{OL} = 100 μA | 2.3 V to 3.6 V | | | 0.2 | V | |
| | | I _{OL} = 4 mA, V _{IL} = 0.7 V | 2.3 V | | | 0.4 | | |
| | | I _{OL} = 6 mA | V _{IL} = 0.7 V | 2.3 V | | | | 0.55 |
| | | | V _{IL} = 0.8 V | 3 V | | | | 0.55 |
| | | I _{OL} = 8 mA, V _{IL} = 0.8 V | 2.7 V | | | 0.6 | | |
| | | I _{OL} = 12 mA, V _{IL} = 0.8 V | 3 V | | | 0.8 | | |
| I _I | | V _I = V _{CC} or GND | 3.6 V | | | ±5 | μA | |
| I _{I(hold)} | | V _I = 0.7 V | 2.3 V | 45 | | | μA | |
| | | V _I = 1.7 V | 2.3 V | -45 | | | | |
| | | V _I = 0.8 V | 3 V | 75 | | | | |
| | | V _I = 2 V | 3 V | -75 | | | | |
| | | V _I = 0 to 3.6 V ² | 3.6 V | | | ±500 | | |
| I _{OZ} | | V _O = V _{CC} or GND | 3.6 V | | | ±10 | μA | |
| I _{CC} | | V _I = V _{CC} or GND, I _O = 0 | 3.6 V | | | 40 | μA | |
| ΔI _{CC} | | One input at V _{CC} - 0.6 V, Other inputs at V _{CC} or GND | 3 V to 3.6 V | | | 750 | μA | |
| C _i | Control inputs | V _I = V _{CC} or GND | 3.3 V | | 3.5 | | pF | |
| | Data inputs | | | | 7.64 | | | |
| C _o | Outputs | V _O = V _{CC} or GND | 3.3 V | | 3.12 | | pF | |

NOTES:

- All typical values are at V_{CC} = 3.3 V, T_{amb} = 25°C.
- This is the bus-hold maximum dynamic current. It is the minimum overdrive current required to switch the input from one state to another.

18-bit to 36-bit address driver with bus hold (3-State)

74ALVCHS162830

SWITCHING CHARACTERISTICS

Over recommended operating free-air temperature range (unless otherwise noted) (see Figures 1 and 2).

| PARAMETER | FROM (INPUT) | TO (OUTPUT) | $V_{CC} = 2.5 V \pm 0.2 V$ | | $V_{CC} = 2.7 V$ | | $V_{CC} = 3.3 V \pm 0.3 V$ | | UNIT |
|---------------|-----------------|-------------|----------------------------|-----|------------------|-----|----------------------------|-----|------|
| | | | MIN | MAX | MIN | MAX | MIN | MAX | |
| t_{pd} | A | Y | 1.2 | 3.8 | | 4 | 1.7 | 3.5 | ns |
| t_{en} | \overline{OE} | Y | 1 | 5.7 | | 5.7 | 1 | 4.8 | ns |
| t_{dis} | \overline{OE} | Y | 1 | 4.9 | | 5.4 | 1.7 | 5.2 | ns |
| $t_{sk(o)}^1$ | Output skew | – | – | – | – | – | – | 500 | ps |

NOTE:

1. Output skew between any 2 outputs of same part switching in the same direction.

OPERATING CHARACTERISTICS, $T_{amb} = 25^\circ C$

| SYMBOL | PARAMETER | | TEST CONDITIONS | $V_{CC} = 2.5 V \pm 0.2 V$ | $V_{CC} = 3.3 V \pm 0.3 V$ | UNIT |
|----------|--|----------------------|-------------------------------|----------------------------|----------------------------|------|
| | | | | TYP | TYP | |
| C_{pd} | Power dissipation capacitance per driver | All outputs enabled | $C_L = 0, f = 10 \text{ MHz}$ | 49 | 53 | pF |
| | | All outputs disabled | | 6 | 7.5 | |

18-bit to 36-bit address driver with bus hold (3-State)

74ALVCHS162830

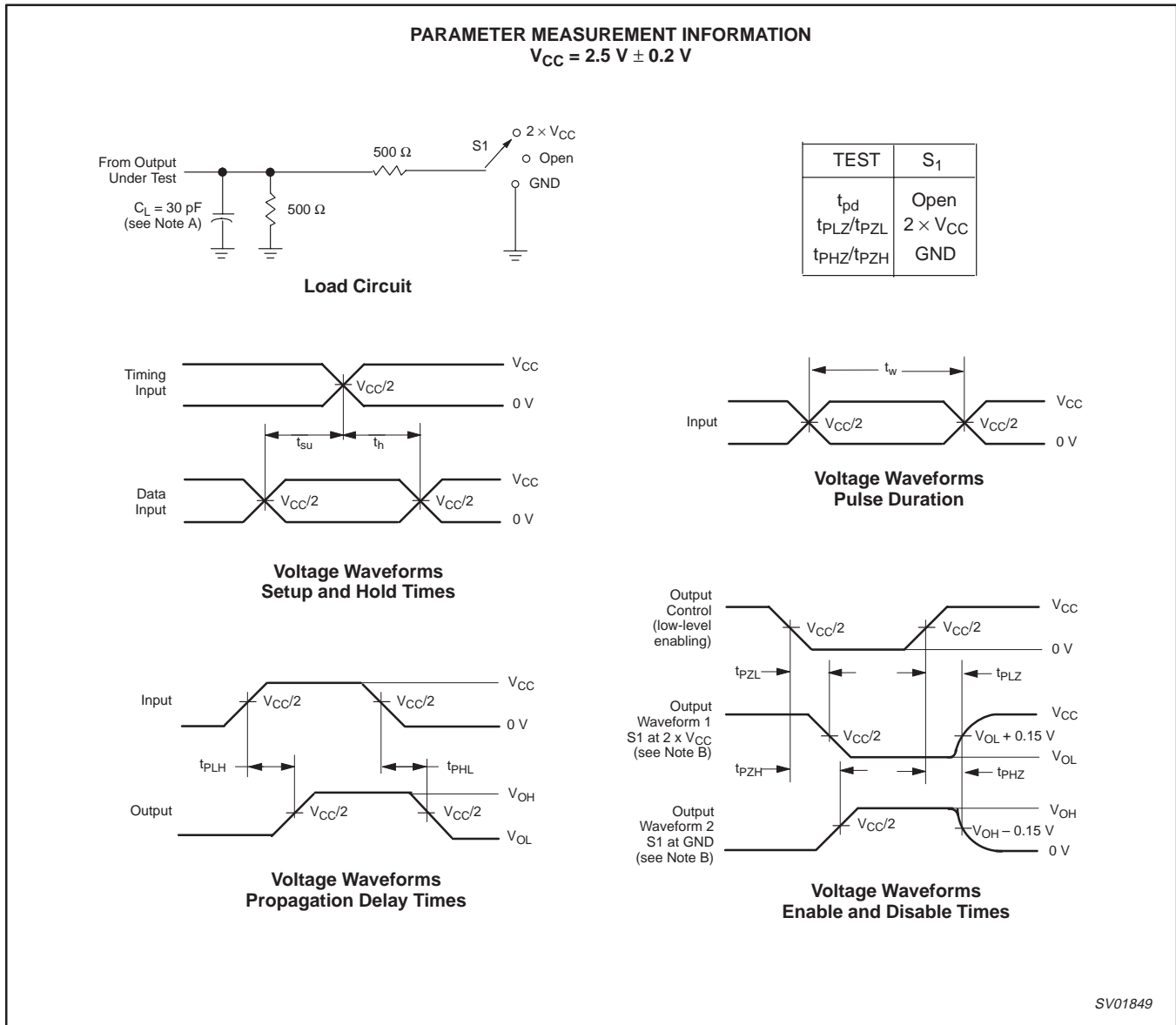

NOTES:

- A. C_L includes probe and jig capacitance.
- B. Waveform 1 is for an output with internal conditions such that the output is low except when disabled by the output control. Waveform 2 is for an output with internal conditions such that the output is high except when disabled by the output control.
- C. All input pulses are supplied by generators having the following characteristics: PRR ≤ 10 MHz, Z_O = 50 Ω, t_r ≤ 2 ns, t_f ≤ 2 ns.
- D. The outputs are measured one at a time with one transition per measurement.
- E. t_{PLZ} and t_{PHZ} are the same as t_{dis}.
- F. t_{PZL} and t_{PZH} are the same as t_{en}.
- G. t_{PLH} and t_{PHL} are the same as t_{pd}.

Figure 1. Load circuit and voltage waveforms

18-bit to 36-bit address driver with bus hold (3-State)

74ALVCHS162830

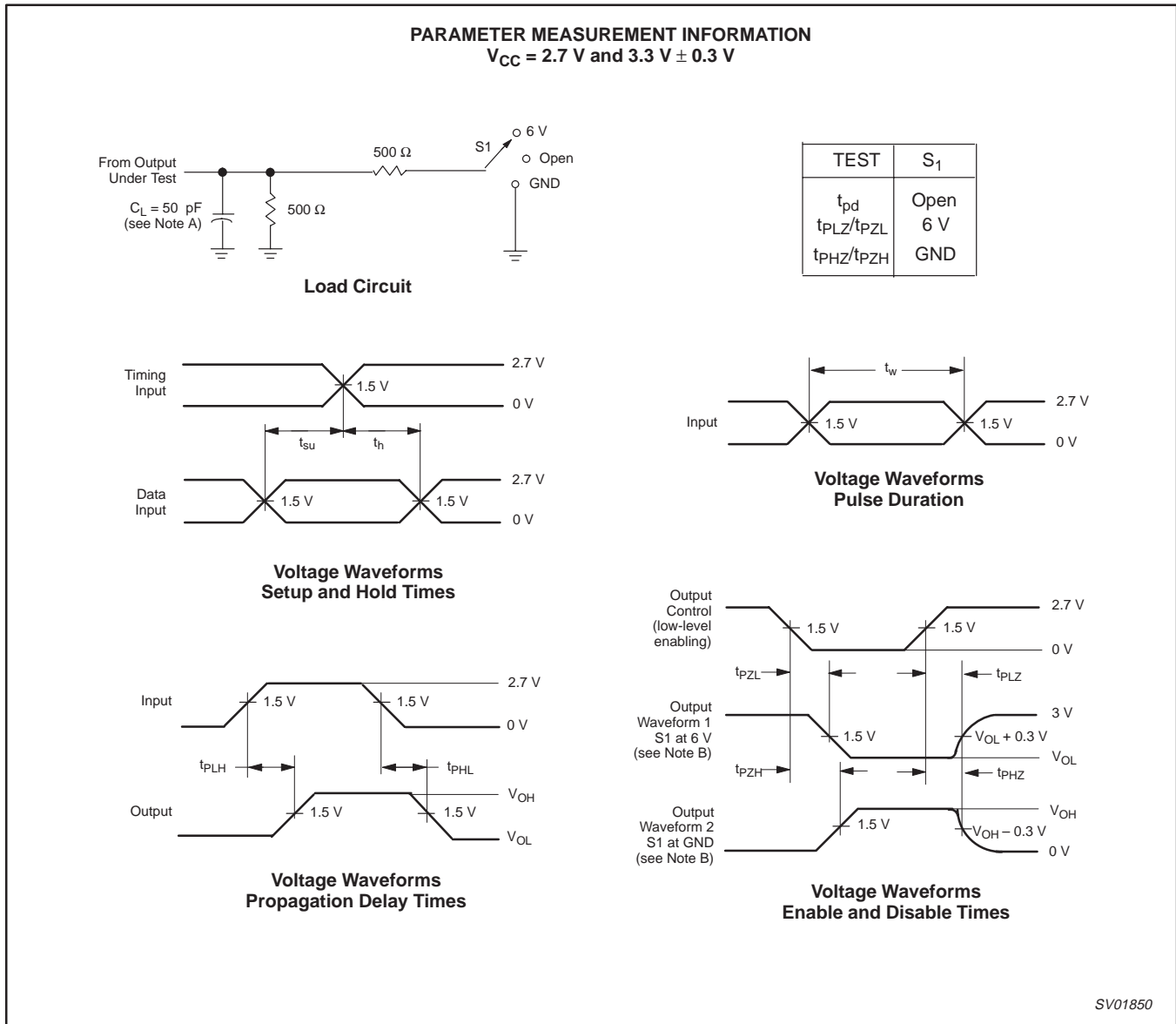

NOTES:

- A. C_L includes probe and jig capacitance.
- B. Waveform 1 is for an output with internal conditions such that the output is low except when disabled by the output control. Waveform 2 is for an output with internal conditions such that the output is high except when disabled by the output control.
- C. All input pulses are supplied by generators having the following characteristics: PRR ≤ 10 MHz, Z_O = 50 Ω, t_r ≤ 2.5 ns, t_f ≤ 2.5 ns.
- D. The outputs are measured one at a time with one transition per measurement.
- E. t_{PLZ} and t_{PHZ} are the same as t_{dis}.
- F. t_{PZL} and t_{PZH} are the same as t_{en}.
- G. t_{PLH} and t_{PHL} are the same as t_{pd}.

Figure 2. Load circuit and voltage waveforms

18-bit to 36-bit address driver with bus hold (3-State)

74ALVCHS162830

TSSOP80: plastic thin shrink small outline package; 80 leads; body width 6.1 mm

SOT647-1

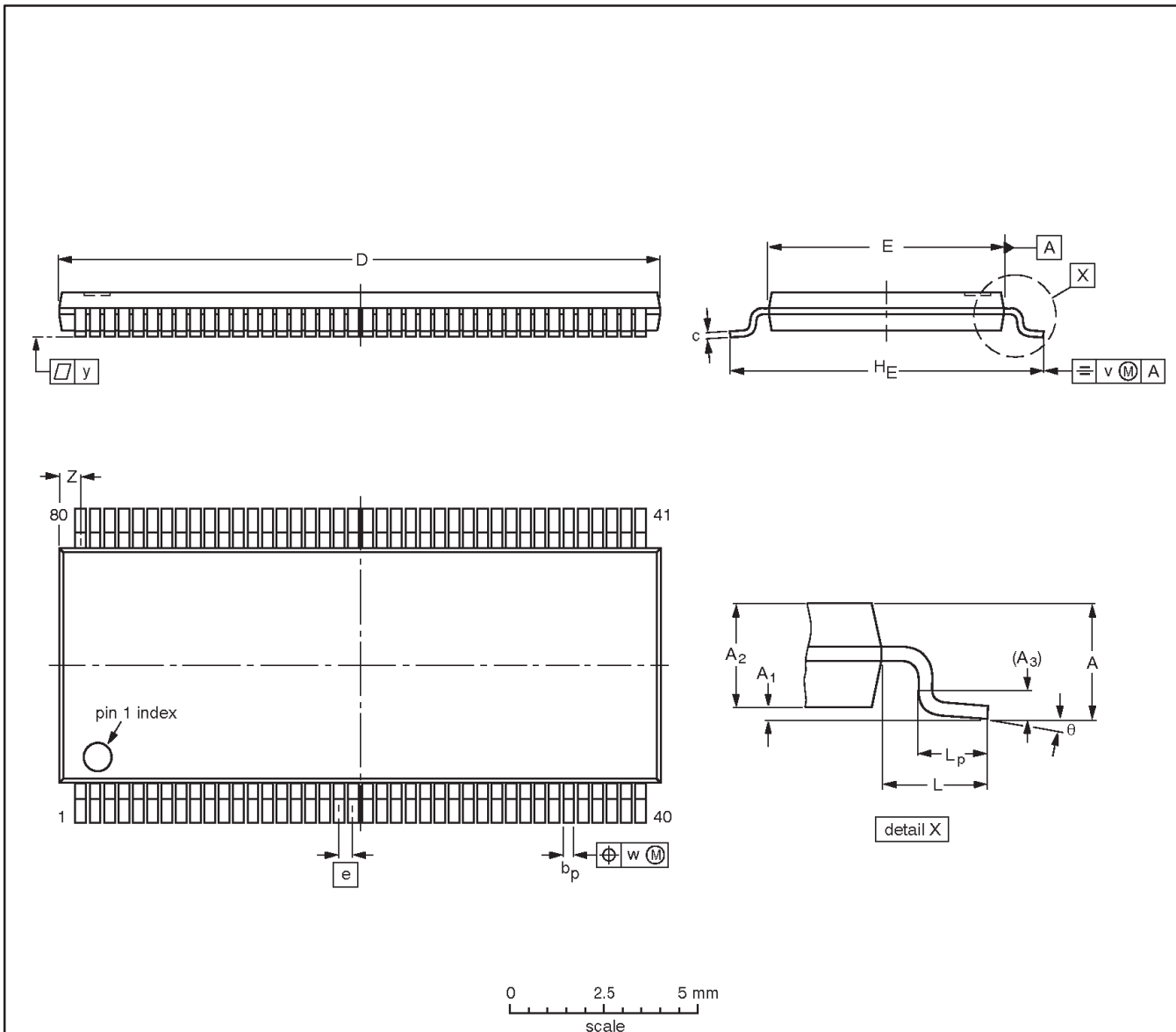

DIMENSIONS (mm are the original dimensions).

| UNIT | A max. | A ₁ | A ₂ | A ₃ | b _p | c | D ⁽¹⁾ | E ⁽²⁾ | e | H _E | L | L _p | v | w | y | Z | θ |
|------|--------|----------------|----------------|----------------|----------------|------------|------------------|------------------|-----|----------------|-----|----------------|-----|------|------|--------------|----------|
| mm | 1.2 | 0.15 0.05 | 1.05 0.85 | 0.25 | 0.23 0.13 | 0.2 0.1 | 17.1 16.9 | 6.2 6.0 | 0.4 | 8.3 7.9 | 1.0 | 0.75 0.45 | 0.2 | 0.07 | 0.08 | 0.84 0.57 | 8° 0° |

Notes

1. Plastic or metal protrusions of 0.15 mm maximum per side are not included.
2. Plastic interlead protrusions of 0.25 mm maximum per side are not included.

| OUTLINE VERSION | REFERENCES | | | | EUROPEAN PROJECTION | ISSUE DATE |
|-----------------|------------|--------|------|--|---------------------|------------|
| | IEC | JEDEC | EIAJ | | | |
| SOT647-1 | | MO-153 | | | | 00-08-21 |

18-bit to 36-bit address driver with bus hold (3-State)

74ALVCHS162830

Data sheet status

| Data sheet status ^[1] | Product status ^[2] | Definitions |
|----------------------------------|-------------------------------|--|
| Objective data | Development | This data sheet contains data from the objective specification for product development. Philips Semiconductors reserves the right to change the specification in any manner without notice. |
| Preliminary data | Qualification | This data sheet contains data from the preliminary specification. Supplementary data will be published at a later date. Philips Semiconductors reserves the right to change the specification without notice, in order to improve the design and supply the best possible product. |
| Product data | Production | This data sheet contains data from the product specification. Philips Semiconductors reserves the right to make changes at any time in order to improve the design, manufacturing and supply. Changes will be communicated according to the Customer Product/Process Change Notification (CPCN) procedure SNW-SQ-650A. |

[1] Please consult the most recently issued data sheet before initiating or completing a design.

[2] The product status of the device(s) described in this data sheet may have changed since this data sheet was published. The latest information is available on the Internet at URL <http://www.semiconductors.philips.com>.

Definitions

Short-form specification — The data in a short-form specification is extracted from a full data sheet with the same type number and title. For detailed information see the relevant data sheet or data handbook.

Limiting values definition — Limiting values given are in accordance with the Absolute Maximum Rating System (IEC 60134). Stress above one or more of the limiting values may cause permanent damage to the device. These are stress ratings only and operation of the device at these or at any other conditions above those given in the Characteristics sections of the specification is not implied. Exposure to limiting values for extended periods may affect device reliability.

Application information — Applications that are described herein for any of these products are for illustrative purposes only. Philips Semiconductors make no representation or warranty that such applications will be suitable for the specified use without further testing or modification.

Disclaimers

Life support — These products are not designed for use in life support appliances, devices or systems where malfunction of these products can reasonably be expected to result in personal injury. Philips Semiconductors customers using or selling these products for use in such applications do so at their own risk and agree to fully indemnify Philips Semiconductors for any damages resulting from such application.

Right to make changes — Philips Semiconductors reserves the right to make changes, without notice, in the products, including circuits, standard cells, and/or software, described or contained herein in order to improve design and/or performance. Philips Semiconductors assumes no responsibility or liability for the use of any of these products, conveys no license or title under any patent, copyright, or mask work right to these products, and makes no representations or warranties that these products are free from patent, copyright, or mask work right infringement, unless otherwise specified.

Contact information

For additional information please visit
<http://www.semiconductors.philips.com>. Fax: +31 40 27 24825

© Koninklijke Philips Electronics N.V. 2001
 All rights reserved. Printed in U.S.A.

Date of release: 09-01

For sales offices addresses send e-mail to:
sales.addresses@www.semiconductors.philips.com

Document order number:

9397 750 09111

Let's make things better.

Looking for pricing, stock, or lifecycle information?

Click below to explore more details on WIN SOURCE:

 [View 74ALVCHS162830DGB](#); on WIN SOURCE

 [NXP / Nexperia](#) Information

Optimize Your Supply Chain with WIN SOURCE Solutions

-  Global Sourcing Solution
-  Obsolete Management
-  Cost Control Management
-  Shortage Management
-  Alternative Solution
-  Excess Inventory Management