

# DATA SHEET

**74ALVCHT16835**

18-bit registered driver (3-State)

Product data

2002 Jun 05

## 18-bit registered driver (3-State)

## 74ALVCHT16835

## FEATURES

- Wide supply voltage range of 2.3 V to 3.6 V
- Complies with JEDEC standard no. 8-1A.
- CMOS low power consumption
- Direct interface with TTL levels
- Current drive  $\pm 24$  mA at 3.0 V
- MULTIBYTE™ flow-through standard pin-out architecture
- Low inductance multiple  $V_{CC}$  and GND pins for minimum noise and ground bounce
- Output drive capability 50  $\Omega$  transmission lines @ 85 °C
- ESD protection exceeds 1500 V HBM per JESD22-A114, A115 and 1000 V CDM per JESD22-C101
- Bus hold on data inputs eliminates the need for external pullup/pulldown resistors

## DESCRIPTION

The 74ALVCHT16835 is a 18-bit registered driver. Data flow is controlled by active low output enable ( $\overline{OE}$ ), active high latch enable (LE) and clock inputs (CP).

When LE is HIGH, the A to Y data flow is transparent. When LE is LOW and CP is held at LOW or HIGH, the data is latched; on the LOW to HIGH transient of CP the A-data is stored in the latch/flip-flop.

When  $\overline{OE}$  is LOW the outputs are active. When  $\overline{OE}$  is HIGH, the outputs go to the high impedance OFF-state. Operation of the  $\overline{OE}$  input does not affect the state of the latch/flip-flop.

To ensure the high-impedance state during power up or power down,  $\overline{OE}$  should be tied to  $V_{CC}$  through a pullup resistor; the minimum value of the resistor is determined by the current-sinking capability of the driver.

## QUICK REFERENCE DATA

GND = 0 V;  $T_{amb} = 25$  °C;  $t_r = t_f \leq 2.5$  ns

SYMBOL	PARAMETER	CONDITIONS	TYPICAL	UNIT	
$t_{PHL}/t_{PLH}$	Propagation delay An to Yn; LE to Yn; CP to Yn	$V_{CC} = 3.3$ V, $C_L = 50$ pF	2.3 2.7 2.2	ns	
$f_{max}$	Maximum clock frequency	$V_{CC} = 3.3$ V, $C_L = 50$ pF	350	MHz	
$C_I$	Input capacitance		4.0	pF	
$C_{I/O}$	Input/Output capacitance		8.0	pF	
$C_{PD}$	Power dissipation capacitance per buffer	$V_I = \text{GND to } V_{CC}^1$	transparent mode	pF	
			Output enabled		13
			Output disabled		3
			Clocked mode		22
Output enabled	15				
Output disabled					

## NOTES:

- $C_{PD}$  is used to determine the dynamic power dissipation ( $P_D$  in  $\mu\text{W}$ ):  
 $P_D = C_{PD} \times V_{CC}^2 \times f_i + \sum (C_L \times V_{CC}^2 \times f_o)$  where:  $f_i$  = input frequency in MHz;  $C_L$  = output load capacitance in pF;  
 $f_o$  = output frequency in MHz;  $V_{CC}$  = supply voltage in V;  $\sum (C_L \times V_{CC}^2 \times f_o)$  = sum of outputs.

## PIN CONFIGURATION

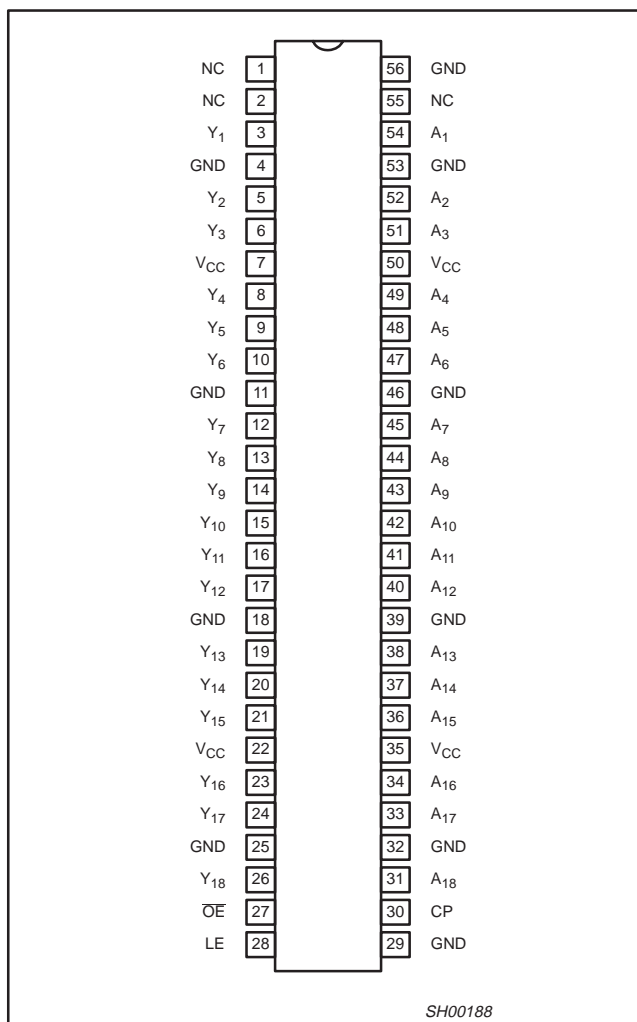

SH00188



# 18-bit registered driver (3-State)

74ALVCHT16835

## LOGIC SYMBOL (IEEE/IEC)

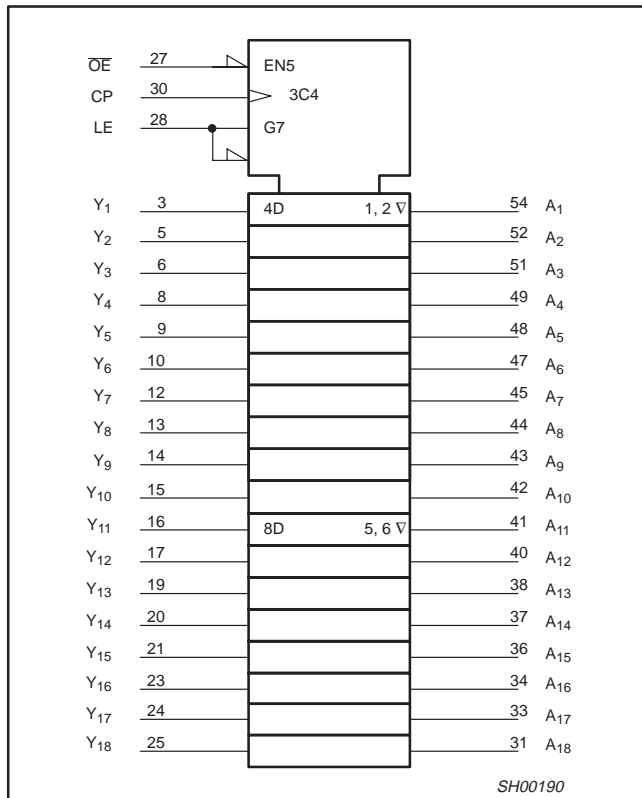

## FUNCTION TABLE

INPUTS				OUTPUTS
OE	LE	CP	A	
H	X	X	X	Z
L	H	X	L	L
L	H	X	H	H
L	L	↑	L	L
L	L	↑	H	H
L	L	H	X	Y <sub>0</sub> <sup>1</sup>
L	L	L	X	Y <sub>0</sub> <sup>2</sup>

- H = HIGH voltage level
- L = LOW voltage level
- X = Don't care
- Z = High impedance "off" state
- ↑ = LOW-to-HIGH level transition

### NOTES:

1. Output level before the indicated steady-state input conditions were established, provided that CP is high before LE goes low.
2. Output level before the indicated steady-state input conditions were established.

## 18-bit registered driver (3-State)

74ALVCHT16835

## RECOMMENDED OPERATING CONDITIONS

SYMBOL	PARAMETER	CONDITIONS	MIN	MAX	UNIT
$V_{CC}$	DC supply voltage 2.5 V range (for max. speed performance @ 30 pF output load)		2.3	2.7	V
	DC supply voltage 3.3 V range (for max. speed performance @ 50 pF output load)		3.0	3.6	
	DC supply voltage (for low-voltage applications)		2.3	3.6	
$V_I$	DC Input voltage range		0	$V_{CC}$	V
$V_O$	DC output voltage range		0	$V_{CC}$	V
$T_{amb}$	Operating free-air temperature range		-40	+85	°C
$t_r, t_f$	Input rise and fall times	$V_{CC} = 2.3$ to $3.0$ V $V_{CC} = 3.0$ to $3.6$ V	0 0	20 10	ns/V

## ABSOLUTE MAXIMUM RATINGS

In accordance with the Absolute Maximum Rating System (IEC 134).  
Voltages are referenced to GND (ground = 0 V).

SYMBOL	PARAMETER	CONDITIONS	RATING	UNIT
$V_{CC}$	DC supply voltage		-0.5 to +4.6	V
$I_{IK}$	DC input diode current	$V_I < 0$	-50	mA
$V_I$	DC input voltage	For control pins <sup>1</sup>	-0.5 to +4.6	V
		For data inputs <sup>1</sup>	-0.5 to $V_{CC} + 0.5$	
$I_{OK}$	DC output diode current	$V_O > V_{CC}$ or $V_O < 0$	±50	mA
$V_O$	DC output voltage	Note 1	-0.5 to $V_{CC} + 0.5$	V
$I_O$	DC output source or sink current	$V_O = 0$ to $V_{CC}$	±50	mA
$I_{GND}, I_{CC}$	DC $V_{CC}$ or GND current		±100	mA
$T_{stg}$	Storage temperature range		-65 to +150	°C
$P_{TOT}$	Power dissipation per package -plastic thin-medium-shrink (TSSOP)	For temperature range: -40 to +125 °C above +55°C derate linearly with 8 mW/K	600	mW
$\theta_{JA}$	Package thermal impedance	See Note 2	93	°C/W

## NOTE:

- The input and output voltage ratings may be exceeded if the input and output current ratings are observed.
- The package thermal impedance is calculated in accordance with JESD 51.

## 18-bit registered driver (3-State)

74ALVCHT16835

**DC ELECTRICAL CHARACTERISTICS**

Over recommended operating conditions. Voltage are referenced to GND (ground = 0 V).

SYMBOL	PARAMETER	TEST CONDITIONS	LIMITS			UNIT
			Temp = -40 to +85 °C			
			MIN	TYP <sup>1</sup>	MAX	
V <sub>IH</sub>	HIGH level Input voltage	V <sub>CC</sub> = 2.3 to 2.7 V	1.7	1.2	—	V
		V <sub>CC</sub> = 2.7 to 3.6 V	2.0	1.5	—	
V <sub>IL</sub>	LOW level Input voltage	V <sub>CC</sub> = 2.3 to 2.7 V	—	1.2	0.7	V
		V <sub>CC</sub> = 2.7 to 3.6 V	—	1.5	0.8	
V <sub>OH</sub>	HIGH level output voltage	V <sub>CC</sub> = 2.3 to 3.6 V; V <sub>I</sub> = V <sub>IH</sub> or V <sub>IL</sub> ; I <sub>O</sub> = -100 μA	V <sub>CC</sub> - 0.2	V <sub>CC</sub>	—	V
		V <sub>CC</sub> = 2.3 V; V <sub>I</sub> = V <sub>IH</sub> or V <sub>IL</sub> ; I <sub>O</sub> = -6 mA	V <sub>CC</sub> - 0.3	V <sub>CC</sub> - 0.08	—	
		V <sub>CC</sub> = 2.3 V; V <sub>I</sub> = V <sub>IH</sub> or V <sub>IL</sub> ; I <sub>O</sub> = -12 mA	V <sub>CC</sub> - 0.6	V <sub>CC</sub> - 0.26	—	
		V <sub>CC</sub> = 2.7 V; V <sub>I</sub> = V <sub>IH</sub> or V <sub>IL</sub> ; I <sub>O</sub> = -12 mA	V <sub>CC</sub> - 0.5	V <sub>CC</sub> - 0.14	—	
		V <sub>CC</sub> = 3.0 V; V <sub>I</sub> = V <sub>IH</sub> or V <sub>IL</sub> ; I <sub>O</sub> = -12 mA	V <sub>CC</sub> - 0.6	V <sub>CC</sub> - 0.09	—	
		V <sub>CC</sub> = 3.0 V; V <sub>I</sub> = V <sub>IH</sub> or V <sub>IL</sub> ; I <sub>O</sub> = -24 mA	V <sub>CC</sub> - 1.0	V <sub>CC</sub> - 0.28	—	
V <sub>OL</sub>	LOW level output voltage	V <sub>CC</sub> = 2.3 to 3.6 V; V <sub>I</sub> = V <sub>IH</sub> or V <sub>IL</sub> ; I <sub>O</sub> = 100 μA	—	GND	0.20	V
		V <sub>CC</sub> = 2.3 V; V <sub>I</sub> = V <sub>IH</sub> or V <sub>IL</sub> ; I <sub>O</sub> = 6 mA	—	0.07	0.40	V
		V <sub>CC</sub> = 2.3 V; V <sub>I</sub> = V <sub>IH</sub> or V <sub>IL</sub> ; I <sub>O</sub> = 12 mA	—	0.15	0.70	V
		V <sub>CC</sub> = 2.7 V; V <sub>I</sub> = V <sub>IH</sub> or V <sub>IL</sub> ; I <sub>O</sub> = 12 mA	—	0.14	0.40	
		V <sub>CC</sub> = 3.0 V; V <sub>I</sub> = V <sub>IH</sub> or V <sub>IL</sub> ; I <sub>O</sub> = 24 mA	—	0.27	0.55	
I <sub>I(hold)</sub>		V <sub>CC</sub> = 2.3 V; V <sub>I</sub> = 0.7 V	45	—	—	μA
		V <sub>CC</sub> = 2.3 V; V <sub>I</sub> = 1.7 V	-45	—	—	
		V <sub>CC</sub> = 3.0 V; V <sub>I</sub> = 0.8 V	75	—	—	
		V <sub>CC</sub> = 3.0 V; V <sub>I</sub> = 2.0 V	-75	—	—	
		V <sub>CC</sub> = 3.6 V; V <sub>I</sub> = 0 to 3.6 V	—	—	±500	
I <sub>I</sub>	Input leakage current	V <sub>CC</sub> = 2.3 to 3.6 V; V <sub>I</sub> = V <sub>CC</sub> or GND	—	0.1	5	μA
I <sub>OZ</sub>	3-State output OFF-state current	V <sub>CC</sub> = 2.3 to 3.6 V; V <sub>I</sub> = V <sub>IH</sub> or V <sub>IL</sub> ; V <sub>O</sub> = V <sub>CC</sub> or GND	—	0.1	10	μA
I <sub>CC</sub>	Quiescent supply current	V <sub>CC</sub> = 2.3 to 3.6 V; V <sub>I</sub> = V <sub>CC</sub> or GND; I <sub>O</sub> = 0	—	30	60	μA
ΔI <sub>CC</sub>	Additional quiescent supply current	V <sub>CC</sub> = 2.3 V to 3.6 V; V <sub>I</sub> = V <sub>CC</sub> - 0.6 V; I <sub>O</sub> = 0	—	150	400	μA
C <sub>i</sub>	Control inputs	V <sub>I</sub> = V <sub>CC</sub> or GND	—	3.5	—	pF
	Data inputs	V <sub>CC</sub> = 3.3 V	—	6	—	
C <sub>o</sub>	Outputs	V <sub>O</sub> = V <sub>CC</sub> or GND V <sub>CC</sub> = 3.3 V	—	7	—	pF

**NOTE:**1. All typical values are at T<sub>amb</sub> = 25 °C.

## 18-bit registered driver (3-State)

74ALVCHT16835

**AC CHARACTERISTICS FOR  $V_{CC} = 2.3 \text{ V TO } 2.7 \text{ V RANGE}$** GND = 0 V;  $t_r = t_f \leq 2.0 \text{ ns}$ ;  $C_L = 30 \text{ pF}$ 

SYMBOL	PARAMETER	WAVEFORM	LIMITS			UNIT
			$V_{CC} = 2.3 \text{ to } 2.7 \text{ V}$			
			MIN	TYP <sup>1</sup>	MAX	
$t_{PHL}/t_{PLH}$	Propagation delay An to Yn	1, 7	1.3	3.0	4.7	ns
	Propagation delay LE to Yn	2, 7	1.4	3.6	5.7	
	Propagation delay CP to Yn	4, 7	1.2	3.0	4.7	
$t_{PZH}/t_{PZL}$	3-State output enable time $\overline{OE}$ to Yn	6, 7	1.4	3.7	5.3	ns
$t_{PHZ}/t_{PLZ}$	3-State output disable time $\overline{OE}$ to Yn	6, 7	1.0	2.5	3.7	ns
$t_W$	CP pulse width HIGH or LOW	4, 7	3.3	—	—	ns
	LE pulse width HIGH	2, 7	3.3	—	—	
$t_{SU}$	Set-up time An to CP	5, 7	0.1	—	—	ns
	Set-up time An to LE	3, 7	0.7	—	—	
$t_h$	Hold time An to CP	5, 7	0.4	—	—	ns
	Hold time An to LE	3, 7	0.1	—	—	
$t_{sk}$	Output skew		—	—	0.5	ns
$f_{max}$	Maximum clock pulse frequency	4, 7	150	—	—	MHz

**NOTE:**

1. All typical values are at  $V_{CC} = 2.5 \text{ V}$  and  $T_{amb} = 25 \text{ }^\circ\text{C}$ .
2. Output skew is not production tested

**AC CHARACTERISTICS FOR  $V_{CC} = 3.0 \text{ V TO } 3.6 \text{ V RANGE AND } V_{CC} = 2.7 \text{ V}$** GND = 0 V;  $t_r = t_f \leq 2.5 \text{ ns}$ ;  $C_L = 50 \text{ pF}$ 

SYMBOL	PARAMETER	WAVEFORM	LIMITS			LIMITS			UNIT
			$V_{CC} = 3.3 \pm 0.3 \text{ V}$			$V_{CC} = 2.7 \text{ V}$			
			MIN	TYP <sup>1, 2</sup>	MAX	MIN	TYP <sup>1</sup>	MAX	
$t_{PHL}/t_{PLH}$	Propagation delay An to Yn	1, 7	1.2	2.3	3.6	1.3	2.7	3.8	ns
	Propagation delay LE to Yn	2, 7	1.3	2.7	4.2	1.4	3.0	4.9	
	Propagation delay CP to Yn	4, 7	1.0	2.2	3.7	1.2	2.3	3.7	
$t_{PZH}/t_{PZL}$	3-State output enable time $\overline{OE}$ to Yn	6, 7	1.0	2.3	3.8	1.4	2.4	4.2	ns
$t_{PHZ}/t_{PLZ}$	3-State output disable time $\overline{OE}$ to Yn	6, 7	1.0	2.5	3.7	1.0	2.5	3.7	ns
$t_W$	CP pulse width HIGH or LOW	4, 7	2.0	—	—	2.0	—	—	ns
	LE pulse width HIGH	2, 7	2.0	—	—	2.0	—	—	
$t_{SU}$	Set-up time An to CP	5, 7	0.1	—	—	0	—	—	ns
	Set-up time An to LE	3, 7	0.5	—	—	0	—	—	
$t_h$	Hold time An to CP	5, 7	0.4	—	—	0.5	0.3	—	ns
	Hold time An to LE	3, 7	0.1	—	—	0.25	0.4	—	
$t_{sk}$	Output skew <sup>3</sup>		—	—	—	—	—	0.5	ns
$f_{max}$	Maximum clock pulse frequency	4, 7	150	—	—	150	—	—	MHz

**NOTES:**

1. All typical values are measured  $T_{amb} = 25 \text{ }^\circ\text{C}$ .
2. Typical value is measured at  $V_{CC} = 3.3 \text{ V}$
3. Output skew is not production tested

# 18-bit registered driver (3-State)

## 74ALVCHT16835

### AC WAVEFORMS FOR $V_{CC} = 3.0\text{ V TO } 3.6\text{ V AND } V_{CC} = 2.7\text{ V RANGE}$

$V_M = 1.5\text{ V}$   
 $V_X = V_{OL} + 0.3\text{ V}$   
 $V_Y = V_{OH} - 0.3\text{ V}$   
 $V_{OL}$  and  $V_{OH}$  are the typical output voltage drop that occur with the output load.  
 $V_I = 2.7\text{ V}$

### AC WAVEFORMS FOR $V_{CC} = 2.3\text{ V TO } 2.7\text{ V AND } V_{CC} < 2.3\text{ V RANGE}$

$V_M = 0.5 V_{CC}$   
 $V_X = V_{OL} + 0.15\text{ V}$   
 $V_Y = V_{OH} - 0.15\text{ V}$   
 $V_{OL}$  and  $V_{OH}$  are the typical output voltage drop that occur with the output load.  
 $V_I = V_{CC}$

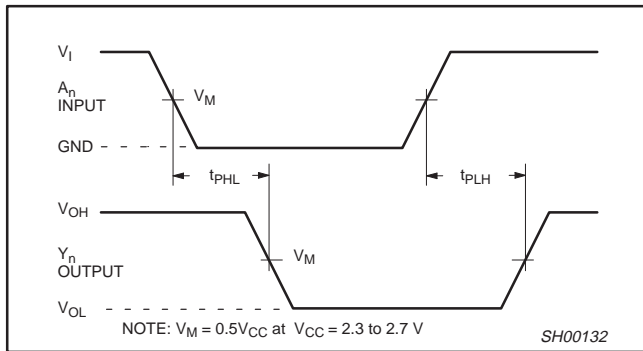

**Waveform 1. Input (An) to output (Yn) propagation delay**

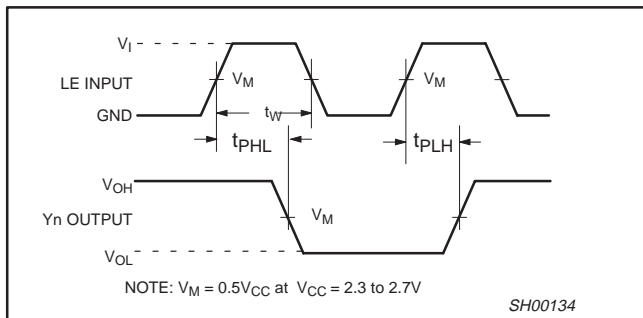

**Waveform 2. Latch enable input (LE) pulse width, the latch enable input to output (Yn) propagation delays.**

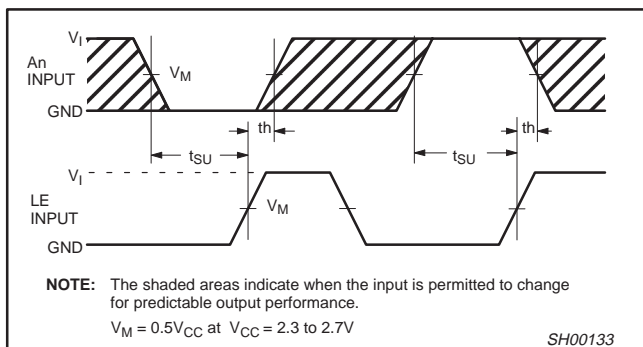

**Waveform 3. Data set-up and hold times for the An input to the LE input**

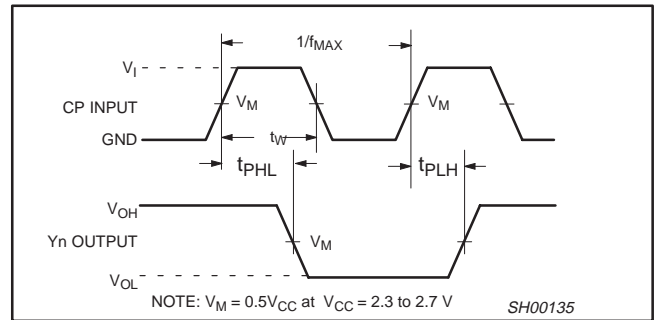

**Waveform 4. The clock (CP) to Yn propagation delays, the clock pulse width and the maximum clock frequency.**

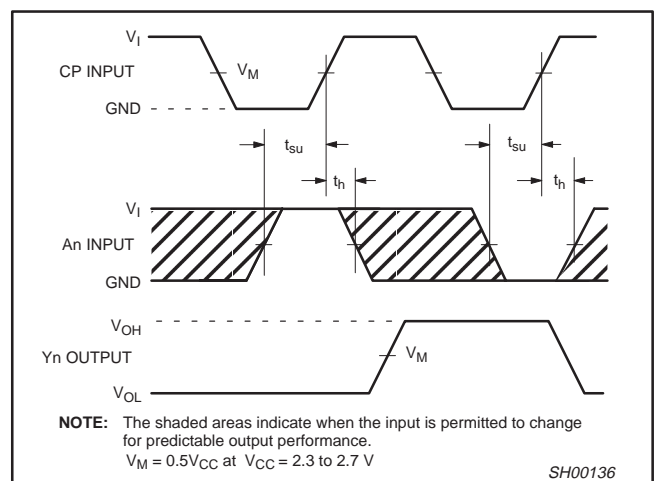

**Waveform 5. Data set-up and hold times for the An input to the clock CP input**

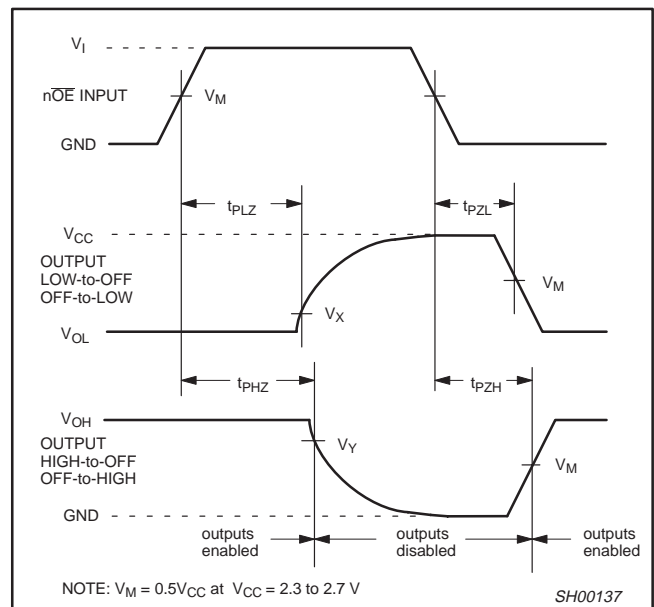

**Waveform 6. 3-State enable and disable times**

# 18-bit registered driver (3-State)

74ALVCHT16835

## TEST CIRCUIT

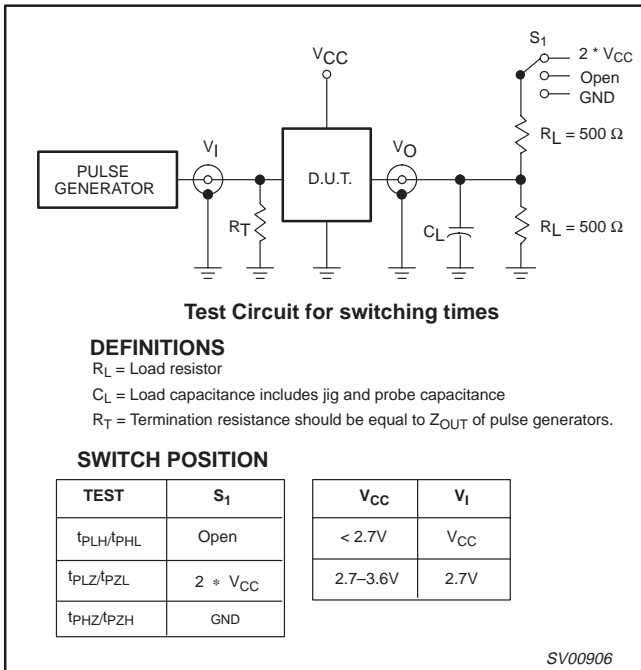

**Waveform 7. Load circuitry for switching times**

# 18-bit registered driver (3-State)

# 74ALVCHT16835

TSSOP56: plastic thin shrink small outline package; 56 leads; body width 4.4 mm

SOT481-2

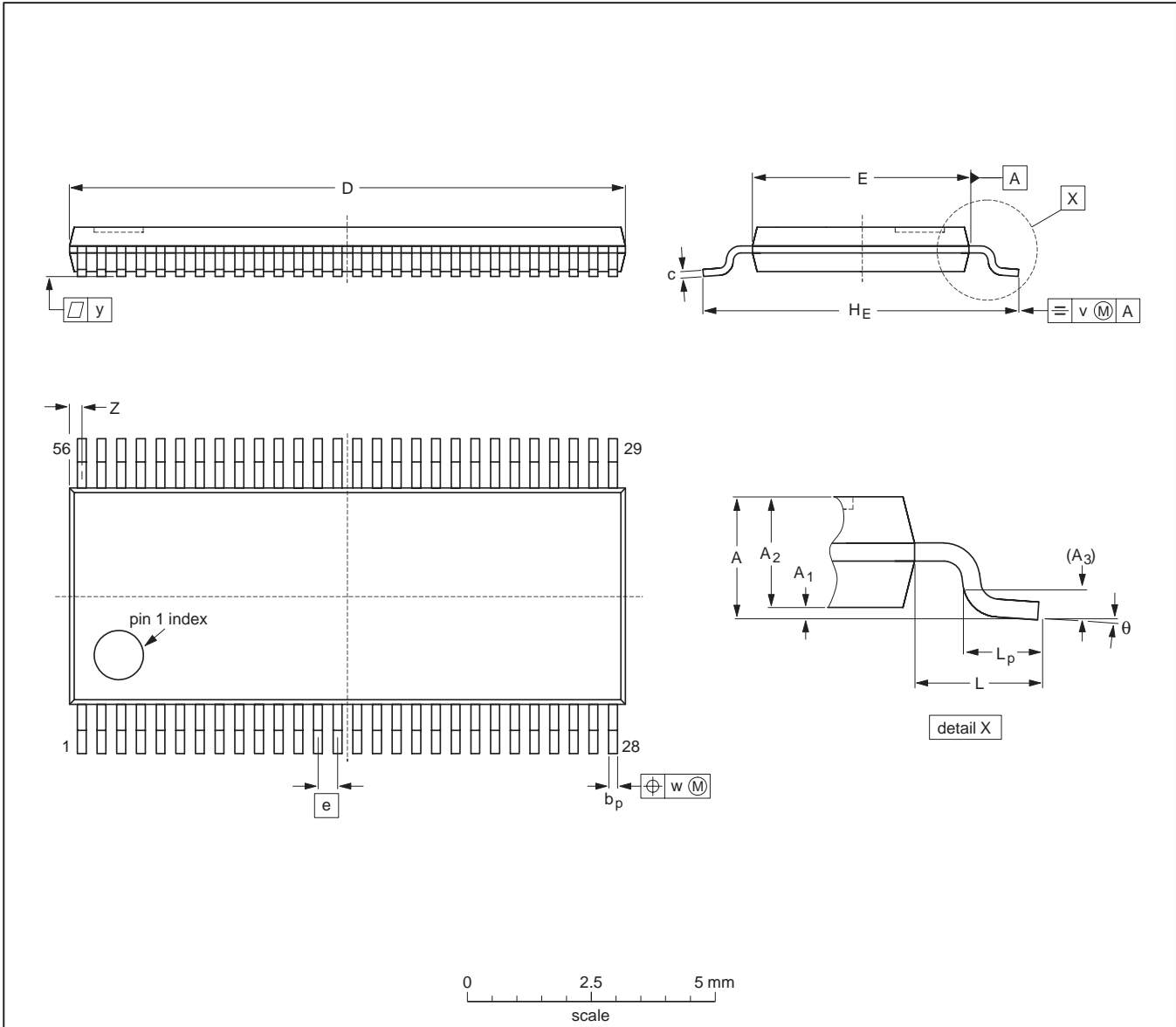

**DIMENSIONS (mm are the original dimensions)**

UNIT	A max.	A1	A2	A3	bp	c	D (1)	E (2)	e	HE	L	Lp	v	w	y	Z (1)	θ
mm	1.2	0.15 0.05	1.05 0.80	0.25	0.23 0.13	0.20 0.09	11.4 11.2	4.5 4.3	0.4	6.6 6.2	1	0.75 0.45	0.2	0.07	0.08	0.4 0.1	8° 0°

**Notes**

1. Plastic or metal protrusions of 0.15 mm maximum per side are not included.
2. Plastic or metal protrusions of 0.25 mm maximum per side are not included.

OUTLINE VERSION	REFERENCES				EUROPEAN PROJECTION	ISSUE DATE
	IEC	JEDEC	JEITA			
SOT481-2	---	MO-194	---			01-11-24

---

18-bit registered driver (3-State)

74ALVCHT16835

---

**NOTES**

## 18-bit registered driver (3-State)

74ALVCHT16835

## Data sheet status

Data sheet status <sup>[1]</sup>	Product status <sup>[2]</sup>	Definitions
Objective data	Development	This data sheet contains data from the objective specification for product development. Philips Semiconductors reserves the right to change the specification in any manner without notice.
Preliminary data	Qualification	This data sheet contains data from the preliminary specification. Supplementary data will be published at a later date. Philips Semiconductors reserves the right to change the specification without notice, in order to improve the design and supply the best possible product.
Product data	Production	This data sheet contains data from the product specification. Philips Semiconductors reserves the right to make changes at any time in order to improve the design, manufacturing and supply. Changes will be communicated according to the Customer Product/Process Change Notification (CPCN) procedure SNW-SQ-650A.

[1] Please consult the most recently issued data sheet before initiating or completing a design.

[2] The product status of the device(s) described in this data sheet may have changed since this data sheet was published. The latest information is available on the Internet at URL <http://www.semiconductors.philips.com>.

## Definitions

**Short-form specification** — The data in a short-form specification is extracted from a full data sheet with the same type number and title. For detailed information see the relevant data sheet or data handbook.

**Limiting values definition** — Limiting values given are in accordance with the Absolute Maximum Rating System (IEC 60134). Stress above one or more of the limiting values may cause permanent damage to the device. These are stress ratings only and operation of the device at these or at any other conditions above those given in the Characteristics sections of the specification is not implied. Exposure to limiting values for extended periods may affect device reliability.

**Application information** — Applications that are described herein for any of these products are for illustrative purposes only. Philips Semiconductors make no representation or warranty that such applications will be suitable for the specified use without further testing or modification.

## Disclaimers

**Life support** — These products are not designed for use in life support appliances, devices or systems where malfunction of these products can reasonably be expected to result in personal injury. Philips Semiconductors customers using or selling these products for use in such applications do so at their own risk and agree to fully indemnify Philips Semiconductors for any damages resulting from such application.

**Right to make changes** — Philips Semiconductors reserves the right to make changes, without notice, in the products, including circuits, standard cells, and/or software, described or contained herein in order to improve design and/or performance. Philips Semiconductors assumes no responsibility or liability for the use of any of these products, conveys no license or title under any patent, copyright, or mask work right to these products, and makes no representations or warranties that these products are free from patent, copyright, or mask work right infringement, unless otherwise specified.

## Contact information

For additional information please visit  
<http://www.semiconductors.philips.com>. Fax: +31 40 27 24825

© Koninklijke Philips Electronics N.V. 2002  
 All rights reserved. Printed in U.S.A.

Date of release: 06-02

For sales offices addresses send e-mail to:  
[sales.addresses@www.semiconductors.philips.com](mailto:sales.addresses@www.semiconductors.philips.com)

Document order number:

9397 750 09943

*Let's make things better.*

## Looking for pricing, stock, or lifecycle information?

Click below to explore more details on WIN SOURCE:

 [View 74ALVCHT16835DGV:1 on WIN SOURCE](#)

 [NXP / Nexperia Information](#)

## Optimize Your Supply Chain with WIN SOURCE Solutions

-  Global Sourcing Solution
-  Obsolete Management
-  Cost Control Management
-  Shortage Management
-  Alternative Solution
-  Excess Inventory Management