



**THE DATASHEET OF  
74F245SC**



# 74F245

## Octal Bidirectional Transceiver with 3-STATE Outputs

### Features

- Non-inverting buffers
- Bidirectional data path
- A outputs sink 24mA
- B outputs sink 64mA

### General Description

The 74F245 contains eight non-inverting bidirectional buffers with 3-STATE outputs and is intended for bus-oriented applications. Current sinking capability is 24mA at the A Ports and 64mA at the B Ports. The Transmit/Receive ( $T/\bar{R}$ ) input determines the direction of data flow through the bidirectional transceiver. Transmit (active HIGH) enables data from A Ports to B Ports; Receive (active LOW) enables data from B Ports to A Ports. The Output Enable input, when HIGH, disables both A and B Ports by placing them in a High Z condition.

### Ordering Information

Order Number	Package Number	Package Description
74F245SC	M20B	20-Lead Small Outline Integrated Circuit (SOIC), JEDEC MS-013, 0.300" Wide
74F245SJ	M20D	20-Lead Small Outline Package (SOP), EIAJ TYPE II, 5.3mm Wide
74F245MSA	MSA20	20-Lead Shrink Small Outline Package (SSOP), JEDEC MO-150, 5.3mm Wide
74F245MTC	MTC20	20-Lead Thin Shrink Small Outline Package (TSSOP), JEDEC MO-153, 4.4mm Wide
74F245PC	N20A	20-Lead Plastic Dual-In-Line Package (PDIP), JEDEC MS-001, 0.300" Wide

Device also available in Tape and Reel. Specify by appending suffix letter "X" to the ordering number.

 All packages are lead free per JEDEC: J-STD-020B standard.

### Connection Diagram

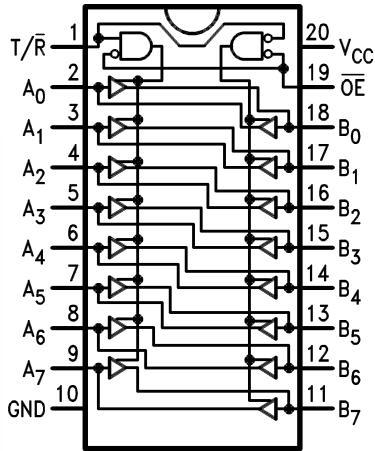

### Logic Symbols

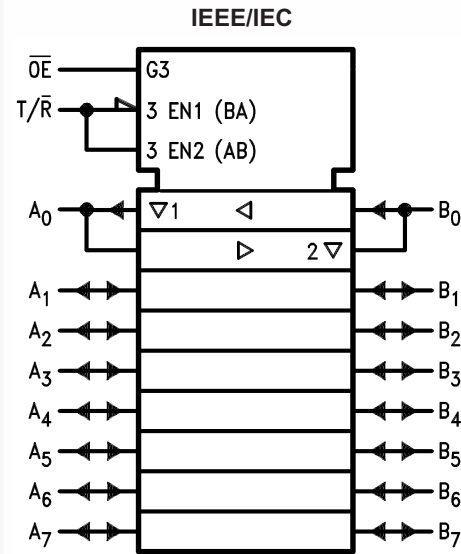
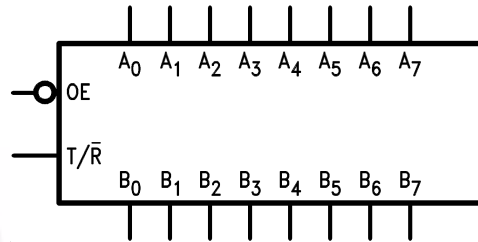

### Truth Table

Inputs		Output
$\overline{OE}$	$T/\overline{R}$	
L	L	Bus B Data to Bus A
L	H	Bus A Data to Bus B
H	X	High Z State

H = HIGH Voltage Level  
 L = LOW Voltage Level  
 X = Immaterial

### Unit Loading/Fan Out

Pin Names	Description	U.L. HIGH/LOW	Input $I_{IH}/I_{IL}$ Output $I_{OH}/I_{OL}$
$\overline{OE}$	Output Enable Input (Active LOW)	1.0/2.0	20 $\mu$ A/-1.2mA
$T/\overline{R}$	Transmit/Receive Input	1.0/2.0	20 $\mu$ A/-1.2mA
$A_0-A_7$	Side A Inputs or 3-STATE Outputs	3.5/1.083 150/40 (38.3)	70 $\mu$ A/-0.65mA -3 mA/24mA (20mA)
$B_0-B_7$	Side B Inputs or 3-STATE Outputs	3.5/1.083 600/106.6 (80)	70 $\mu$ A/-0.65mA -12mA/64mA (48mA)

## Absolute Maximum Ratings

Stresses exceeding the absolute maximum ratings may damage the device. The device may not function or be operable above the recommended operating conditions and stressing the parts to these levels is not recommended. In addition, extended exposure to stresses above the recommended operating conditions may affect device reliability. The absolute maximum ratings are stress ratings only.

Symbol	Parameter	Rating
$T_{STG}$	Storage Temperature	-65°C to +150°C
$T_A$	Ambient Temperature Under Bias	-55°C to +125°C
$T_J$	Junction Temperature Under Bias	-55°C to +150°C
$V_{CC}$	$V_{CC}$ Pin Potential to Ground Pin	-0.5V to +7.0V
$V_I$	Input Voltage <sup>(1)</sup>	-0.5V to +7.0V
$I_I$	Input Current <sup>(1)</sup>	-30mA to +5.0mA
	Voltage Applied to Output in HIGH State (with $V_{CC} = 0V$ )	
	Standard Output	-0.5V to $V_{CC}$
	3-STATE Output	-0.5V to +5.5V
	Current Applied to Output in LOW State (Max.)	twice the rated $I_{OL}$ (mA)
	ESD Last Passing Voltage (Min.)	4000V

### Note:

1. Either voltage limit or current limit is sufficient to protect inputs.

## Recommended Operating Conditions

The Recommended Operating Conditions table defines the conditions for actual device operation. Recommended operating conditions are specified to ensure optimal performance to the datasheet specifications. Fairchild does not recommend exceeding them or designing to absolute maximum ratings.

Symbol	Parameter	Rating
$T_A$	Free Air Ambient Temperature	0°C to +70°C
$V_{CC}$	Supply Voltage	+4.5V to +5.5V

## DC Electrical Characteristics

Symbol	Parameter	$V_{CC}$	Conditions	Min.	Typ.	Max.	Units
$V_{IH}$	Input HIGH Voltage		Recognized as a HIGH Signal	2.0			V
$V_{IL}$	Input LOW Voltage		Recognized as a LOW Signal			0.8	V
$V_{CD}$	Input Clamp Diode Voltage	Min.	$I_{IN} = -18\text{mA}$			-1.2	V
$V_{OH}$	Output HIGH Voltage	10% $V_{CC}$	Min. $I_{OH} = -3\text{mA}$ ( $A_n$ )	2.4			V
		10% $V_{CC}$		$I_{OH} = -15\text{mA}$ ( $B_n$ )	2.0		
		5% $V_{CC}$		$I_{OH} = -3\text{mA}$ ( $A_n$ )	2.7		
$V_{OL}$	Output LOW Voltage	10% $V_{CC}$	Min. $I_{OL} = 24\text{mA}$ ( $A_n$ )			0.5	V
		10% $V_{CC}$		$I_{OL} = 64\text{mA}$ ( $B_n$ )			
$I_{IH}$	Input HIGH Current	Max.	$V_{IN} = 2.7\text{V}$			5.0	$\mu\text{A}$
$I_{BVI}$	Input HIGH Current Breakdown Test	Max.	$V_{IN} = 7.0\text{V}$ ( $\overline{OE}$ , $T/\overline{R}$ )			7.0	$\mu\text{A}$
$I_{BVIT}$	Input HIGH Current Breakdown (I/O)	Max.	$V_{IN} = 5.5\text{V}$ ( $A_n$ , $B_n$ )			0.5	mA
$I_{CEX}$	Output HIGH Leakage Current	Max.	$V_{OUT} = V_{CC}$ ( $A_n$ , $B_n$ )			50	$\mu\text{A}$
$V_{ID}$	Input Leakage Test	0.0	$I_{ID} = 1.9\mu\text{A}$ , All Other Pins Grounded	4.75			V
$I_{OD}$	Output Leakage Circuit Current	0.0	$V_{IOD} = 150\text{mV}$ , All Other Pins Grounded			3.75	$\mu\text{A}$
$I_{IL}$	Input LOW Current	Max.	$V_{IN} = 0.5\text{V}$ ( $T/\overline{R}$ , $\overline{OE}$ )			-1.2	mA
$I_{IH} + I_{OZH}$	Output Leakage Current	Max.	$V_{OUT} = 2.7\text{V}$ ( $A_n$ , $B_n$ )			70	$\mu\text{A}$
$I_{IL} + I_{OZL}$	Output Leakage Current	Max.	$V_{OUT} = 0.5\text{V}$ ( $A_n$ , $B_n$ )			-650	$\mu\text{A}$
$I_{OS}$	Output Short-Circuit Current	Max.	$V_{OUT} = 0\text{V}$ ( $A_n$ )	-60		-150	mA
			$V_{OUT} = 0\text{V}$ ( $B_n$ )	-100		-225	
$I_{ZZ}$	Bus Drainage Test	0.0V	$V_{OUT} = 5.25\text{V}$ ( $A_n$ , $B_n$ )			500	$\mu\text{A}$
$I_{CCH}$	Power Supply Current	Max.	$V_O = \text{HIGH}$		70	90	mA
$I_{CCL}$	Power Supply Current	Max.	$V_O = \text{LOW}$		95	120	mA
$I_{CCZ}$	Power Supply Current	Max.	$V_O = \text{HIGH Z}$		85	110	mA

## AC Electrical Characteristics

Symbol	Parameter	$T_A = +25^\circ\text{C}$ , $V_{CC} = +5.0\text{V}$ , $C_L = 50\text{pF}$			$T_A = -55^\circ\text{C to } +125^\circ\text{C}$ , $C_L = 50\text{pF}$		$T_A = 0^\circ\text{C to } +70^\circ\text{C}$ , $C_L = 50\text{pF}$		Units
		Min.	Typ.	Max.	Min.	Max.	Min.	Max.	
$t_{PLH}$ , $t_{PHL}$	Propagation Delay, $A_n$ to $B_n$ or $B_n$ to $A_n$	2.5	4.2	6.0	2.0	7.5	2.0	7.0	ns
		2.5	4.2	6.0	2.0	7.5	2.0	7.0	
$t_{PZH}$ , $t_{PZL}$	Output Enable Time	3.0	5.3	7.0	2.5	9.0	2.5	8.0	ns
		3.5	6.0	8.0	3.0	10.0	3.0	9.0	
$t_{PHZ}$ , $t_{PLZ}$	Output Disable Time	2.0	5.0	6.5	2.0	9.0	2.0	7.5	ns
		2.0	5.0	6.5	2.0	10.0	2.0	7.5	

Physical Dimensions



Figure 1. 20-Lead Small Outline Integrated Circuit (SOIC), JEDEC MS-013, 0.300" Wide

Package drawings are provided as a service to customers considering Fairchild components. Drawings may change in any manner without notice. Please note the revision and/or date on the drawing and contact a Fairchild Semiconductor representative to verify or obtain the most recent revision. Package specifications do not expand the terms of Fairchild's worldwide terms and conditions, specifically the warranty therein, which covers Fairchild products.

Always visit Fairchild Semiconductor's online packaging area for the most recent package drawings:

<http://www.fairchildsemi.com/packaging/>

Physical Dimensions (Continued)



- NOTES:
- A. CONFORMS TO EIAJ EDR-7320 REGISTRATION, ESTABLISHED IN DECEMBER, 1998.
  - B. DIMENSIONS ARE IN MILLIMETERS.
  - C. DIMENSIONS ARE EXCLUSIVE OF BURRS, MOLD FLASH, AND TIE BAR EXTRUSIONS.

M20DREVC

Figure 2. 20-Lead Small Outline Package (SOP), EIAJ TYPE II, 5.3mm Wide

Package drawings are provided as a service to customers considering Fairchild components. Drawings may change in any manner without notice. Please note the revision and/or date on the drawing and contact a Fairchild Semiconductor representative to verify or obtain the most recent revision. Package specifications do not expand the terms of Fairchild's worldwide terms and conditions, specifically the warranty therein, which covers Fairchild products.

Always visit Fairchild Semiconductor's online packaging area for the most recent package drawings:

<http://www.fairchildsemi.com/packaging/>

Physical Dimensions (Continued)

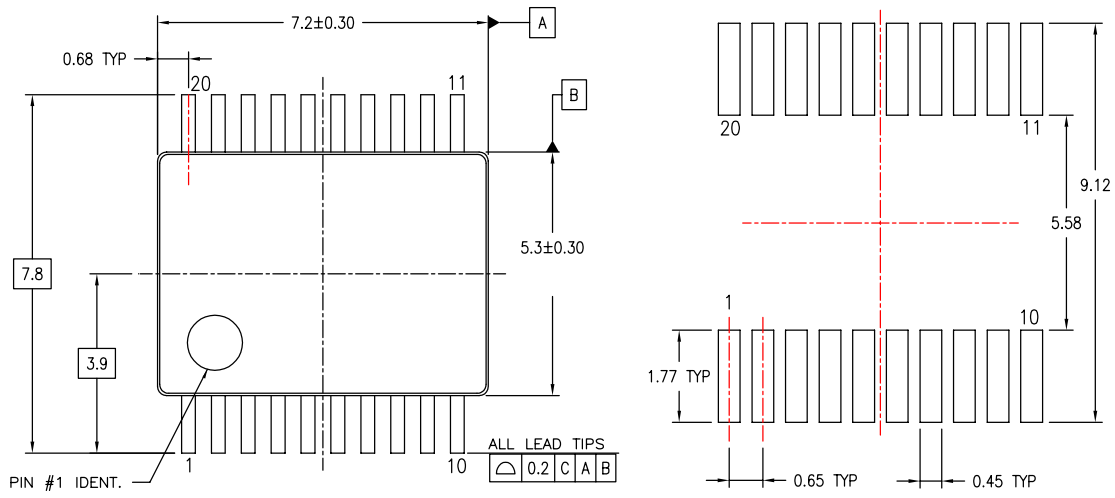

LAND PATTERN RECOMMENDATIONS

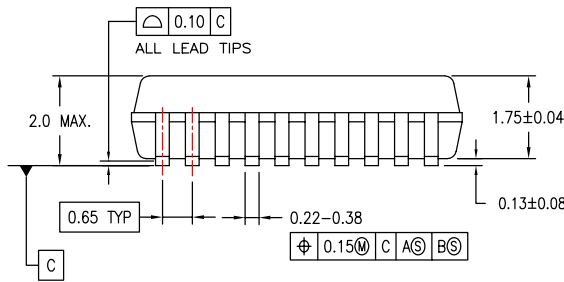
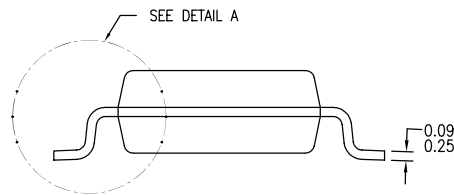

DIMENSIONS ARE IN MILLIMETERS

NOTES:

- A. CONFORMS TO JEDEC REGISTRATION MO-150, VARIATION AE, DATE 1/94.
- B. DIMENSIONS ARE IN MILLIMETERS.
- C. DIMENSIONS ARE EXCLUSIVE OF BURRS, MOLD FLASH, AND TIE BAR EXTRUSIONS.
- D. DIMENSIONS AND TOLERANCES PER ASME Y14.5M - 1994.

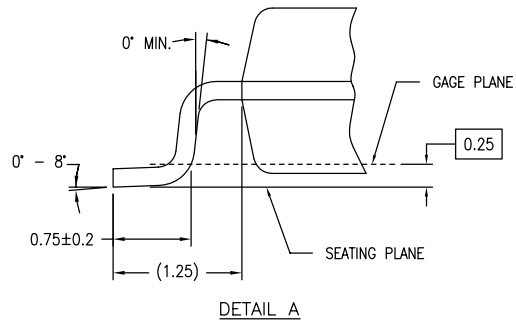

MSA20REV B

Figure 3. 20-Lead Shrink Small Outline Package (SSOP), JEDEC MO-150, 5.3mm Wide

Package drawings are provided as a service to customers considering Fairchild components. Drawings may change in any manner without notice. Please note the revision and/or date on the drawing and contact a Fairchild Semiconductor representative to verify or obtain the most recent revision. Package specifications do not expand the terms of Fairchild's worldwide terms and conditions, specifically the warranty therein, which covers Fairchild products.

Always visit Fairchild Semiconductor's online packaging area for the most recent package drawings:

<http://www.fairchildsemi.com/packaging/>

Physical Dimensions (Continued)

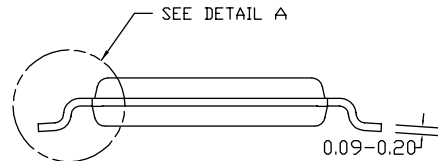
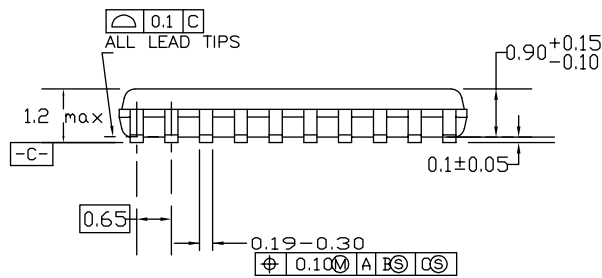
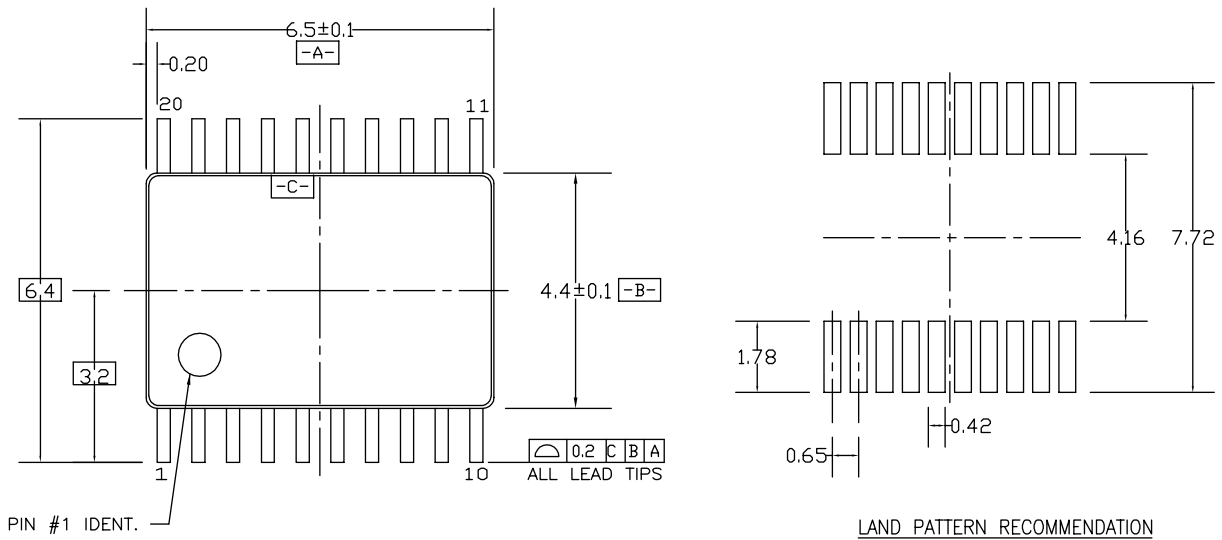

DIMENSIONS ARE IN MILLIMETERS

NOTES:

- A. CONFORMS TO JEDEC REGISTRATION MO-153, VARIATION AC, REF NOTE 6, DATE 7/93.
- B. DIMENSIONS ARE IN MILLIMETERS.
- C. DIMENSIONS ARE EXCLUSIVE OF BURRS, MOLDS FLASH, AND TIE BAR EXTRUSIONS.
- D. DIMENSIONS AND TOLERANCES PER ANSI Y14.5M, 1982.

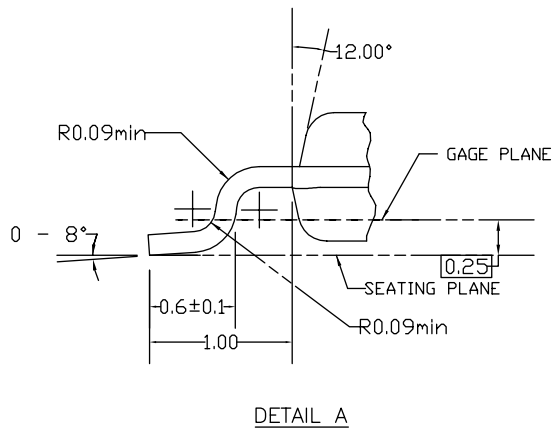

MTC20REV D1

Figure 4. 20-Lead Thin Shrink Small Outline Package (TSSOP), JEDEC MO-153, 4.4mm Wide

Package drawings are provided as a service to customers considering Fairchild components. Drawings may change in any manner without notice. Please note the revision and/or date on the drawing and contact a Fairchild Semiconductor representative to verify or obtain the most recent revision. Package specifications do not expand the terms of Fairchild's worldwide terms and conditions, specifically the warranty therein, which covers Fairchild products.

Always visit Fairchild Semiconductor's online packaging area for the most recent package drawings:

<http://www.fairchildsemi.com/packaging/>

Physical Dimensions (Continued)

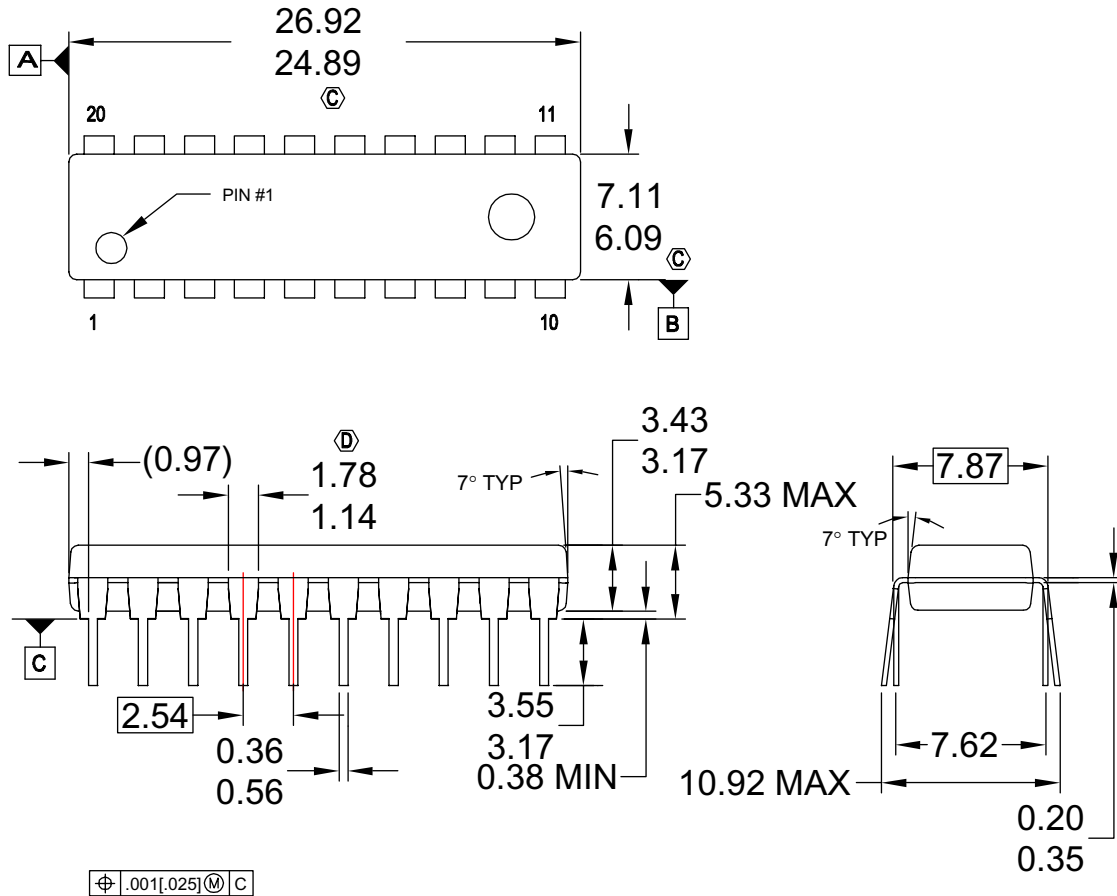

NOTES:

- A. CONFORMS TO JEDEC REGISTRATION MS-001, VARIATIONS AD.
- B. ALL DIMENSIONS ARE IN MILLIMETERS
- C. DOES NOT INCLUDE MOLD FLASH OR PROTRUSIONS. MOLD FLASH OR PROTRUSIONS SHALL NOT EXCEED 0.25MM.
- D. DOES NOT INCLUDE DAMBAR PROTRUSIONS. DAMBAR PROTRUSIONS SHALL NOT EXCEED 0.25MM.
- E. DIMENSIONING AND TOLERANCING PER ASME Y14.5M-1994.
- F. DRAWING FILE NAME: N20AREV8

Figure 5. 20-Lead Plastic Dual-In-Line Package (PDIP), JEDEC MS-001, 0.300" Wide

Package drawings are provided as a service to customers considering Fairchild components. Drawings may change in any manner without notice. Please note the revision and/or date on the drawing and contact a Fairchild Semiconductor representative to verify or obtain the most recent revision. Package specifications do not expand the terms of Fairchild's worldwide terms and conditions, specifically the warranty therein, which covers Fairchild products.



Always visit Fairchild Semiconductor's online packaging area for the most recent package drawings:

<http://www.fairchildsemi.com/packaging/>



**TRADEMARKS**

The following includes registered and unregistered trademarks and service marks, owned by Fairchild Semiconductor and/or its global subsidiaries, and is not intended to be an exhaustive list of all such trademarks.

ACEx <sup>®</sup>	FPST <sup>™</sup>	PDP-SPM <sup>™</sup>	SyncFET <sup>™</sup>
Build it Now <sup>™</sup>	FRFET <sup>®</sup>	Power220 <sup>®</sup>	SYSTEM GENERAL <sup>®</sup>
CorePLUS <sup>™</sup>	Global Power Resource <sup>SM</sup>	Power247 <sup>®</sup>	The Power Franchise <sup>®</sup>
CROSSVOLT <sup>™</sup>	Green FPS <sup>™</sup>	POWEREDGE <sup>®</sup>	the power <sup>™</sup>
CTL <sup>™</sup>	Green FPS <sup>™</sup> e-Series <sup>™</sup>	Power-SPM <sup>™</sup>	franchise
Current Transfer Logic <sup>™</sup>	GTO <sup>™</sup>	PowerTrench <sup>®</sup>	TinyBoost <sup>™</sup>
EcoSPARK <sup>®</sup>	i-Lo <sup>™</sup>	Programmable Active Droop <sup>™</sup>	TinyBuck <sup>™</sup>
EZSWITCH <sup>™</sup> *	IntelliMAX <sup>™</sup>	QFET <sup>®</sup>	TinyLogic <sup>®</sup>
 ™	ISOPLANAR <sup>™</sup>	QS <sup>™</sup>	TINYOPTO <sup>™</sup>
 ™	MegaBuck <sup>™</sup>	QT Optoelectronics <sup>™</sup>	TinyPower <sup>™</sup>
Fairchild <sup>®</sup>	MICROCOUPLER <sup>™</sup>	Quiet Series <sup>™</sup>	TinyPWM <sup>™</sup>
Fairchild Semiconductor <sup>®</sup>	MicroFET <sup>™</sup>	RapidConfigure <sup>™</sup>	TinyWire <sup>™</sup>
FACT Quiet Series <sup>™</sup>	MicroPak <sup>™</sup>	SMART START <sup>™</sup>	μSerDes <sup>™</sup>
FACT <sup>®</sup>	MillerDrive <sup>™</sup>	SPM <sup>®</sup>	UHC <sup>®</sup>
FAST <sup>®</sup>	Motion-SPM <sup>™</sup>	STEALTH <sup>™</sup>	Ultra FRFET <sup>™</sup>
FastvCore <sup>™</sup> *	OPTOLOGIC <sup>®</sup>	SuperFET <sup>™</sup>	UniFET <sup>™</sup>
FlashWriter <sup>®</sup> *	OPTOPLANAR <sup>®</sup>	SuperSOT <sup>™</sup> -3	VCX <sup>™</sup>
		SuperSOT <sup>™</sup> -6	
		SuperSOT <sup>™</sup> -8	

\* EZSWITCH<sup>™</sup> and FlashWriter<sup>®</sup> are trademarks of System General Corporation, used under license by Fairchild Semiconductor.

**DISCLAIMER**

FAIRCHILD SEMICONDUCTOR RESERVES THE RIGHT TO MAKE CHANGES WITHOUT FURTHER NOTICE TO ANY PRODUCTS HEREIN TO IMPROVE RELIABILITY, FUNCTION, OR DESIGN. FAIRCHILD DOES NOT ASSUME ANY LIABILITY ARISING OUT OF THE APPLICATION OR USE OF ANY PRODUCT OR CIRCUIT DESCRIBED HEREIN; NEITHER DOES IT CONVEY ANY LICENSE UNDER ITS PATENT RIGHTS, NOR THE RIGHTS OF OTHERS. THESE SPECIFICATIONS DO NOT EXPAND THE TERMS OF FAIRCHILD'S WORLDWIDE TERMS AND CONDITIONS, SPECIFICALLY THE WARRANTY THEREIN, WHICH COVERS THESE PRODUCTS.

**LIFE SUPPORT POLICY**

FAIRCHILD'S PRODUCTS ARE NOT AUTHORIZED FOR USE AS CRITICAL COMPONENTS IN LIFE SUPPORT DEVICES OR SYSTEMS WITHOUT THE EXPRESS WRITTEN APPROVAL OF FAIRCHILD SEMICONDUCTOR CORPORATION.

As used herein:

1. Life support devices or systems are devices or systems which, (a) are intended for surgical implant into the body or (b) support or sustain life, and (c) whose failure to perform when properly used in accordance with instructions for use provided in the labeling, can be reasonably expected to result in a significant injury of the user.
2. A critical component in any component of a life support, device, or system whose failure to perform can be reasonably expected to cause the failure of the life support device or system, or to affect its safety or effectiveness.

**PRODUCT STATUS DEFINITIONS**

**Definition of Terms**

Datasheet Identification	Product Status	Definition
Advance Information	Formative or In Design	This datasheet contains the design specifications for product development. Specifications may change in any manner without notice.
Preliminary	First Production	This datasheet contains preliminary data; supplementary data will be published at a later date. Fairchild Semiconductor reserves the right to make changes at any time without notice to improve design.
No Identification Needed	Full Production	This datasheet contains final specifications. Fairchild Semiconductor reserves the right to make changes at any time without notice to improve the design.
Obsolete	Not In Production	This datasheet contains specifications on a product that has been discontinued by Fairchild Semiconductor. The datasheet is printed for reference information only.

Rev. I32

## Looking for pricing, stock, or lifecycle information?

Click below to explore more details on WIN SOURCE:

- ⊖ [View 74F245SC on WIN SOURCE](#)
- ⊖ [Fairchild/ON Semiconductor Information](#)

## Optimize Your Supply Chain with WIN SOURCE Solutions

- ✓ Global Sourcing Solution
- ✓ Obsolete Management
- ✓ Cost Control Management
- ✓ Shortage Management
- ✓ Alternative Solution
- ✓ Excess Inventory Management