



**THE DATASHEET OF  
74F543NT**



# SN74F543 OCTAL REGISTERED TRANSCEIVER WITH 3-STATE OUTPUTS

SDFS025B – D2942, MARCH 1987 – REVISED OCTOBER 1993

- 3-State True Outputs
- Back-to-Back Registers for Storage
- Package Options Include Plastic Small-Outline and Shrink Small-Outline Packages and Standard Plastic 300-mil DIPs

## description

The SN74F543 octal transceiver contains two sets of D-type latches for temporary storage of data flowing in either direction. Separate latch-enable ( $\overline{LEAB}$  or  $\overline{LEBA}$ ) and output enable ( $\overline{OEAB}$  or  $\overline{OEBA}$ ) inputs are provided for each register to permit independent control in either direction of data flow. The A outputs are characterized to sink 24 mA while the B outputs are characterized to sink 64 mA.

The A-to-B enable ( $\overline{CEAB}$ ) input must be low in order to enter data from A or to output data from B. Having  $\overline{CEAB}$  low and  $\overline{LEAB}$  low makes the A-to-B latches transparent; a subsequent low-to-high transition of  $\overline{LEAB}$  puts the A latches in the storage mode. With  $\overline{CEAB}$  and  $\overline{OEAB}$  both low, the 3-state B outputs are active and reflect the data present at the output of the A latches. Data flow from B to A is similar, but requires using the  $\overline{CEBA}$ ,  $\overline{LEBA}$ , and  $\overline{OEBA}$  inputs.

The SN74F543 is available in TI's shrink small-outline package (DB), which provides the same I/O pin count and functionality of standard small-outline packages in less than half the printed-circuit-board area.

The SN74F543 is characterized for operation from 0°C to 70°C.

DB, DW, OR NT PACKAGE  
(TOP VIEW)

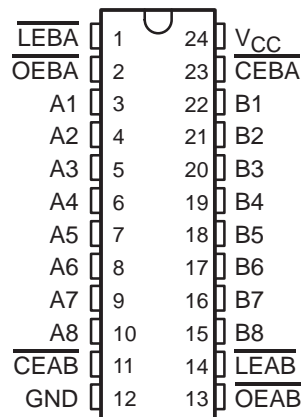

FUNCTION TABLE†

INPUTS				OUTPUT
$\overline{CEAB}$	$\overline{LEAB}$	$\overline{OEAB}$	A	B
H	X	X	X	Z
X	X	H	X	Z
L	H	L	X	$B_0^\ddagger$
L	L	L	L	L
L	L	L	H	H

† A-to-B data flow is shown; B-to-A flow control is the same except that it uses  $\overline{CEBA}$ ,  $\overline{LEBA}$ , and  $\overline{OEBA}$ .

‡ Output level before the indicated steady-state input conditions were established.

# SN74F543 OCTAL REGISTERED TRANSCIEVER WITH 3-STATE OUTPUTS

SDFS025B – D2942, MARCH 1987 – REVISED OCTOBER 1993

## logic symbol†

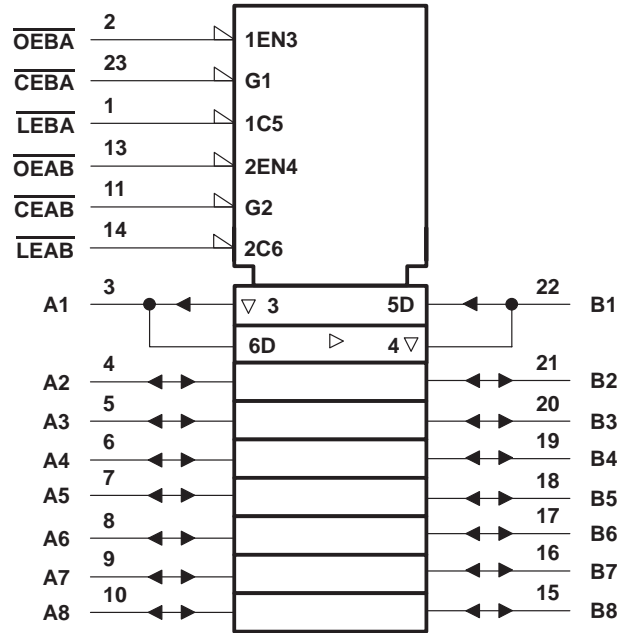

† This symbol is in accordance with ANSI/IEEE Std 91-1984 and IEC Publication 617-12.

## logic diagram (positive logic)

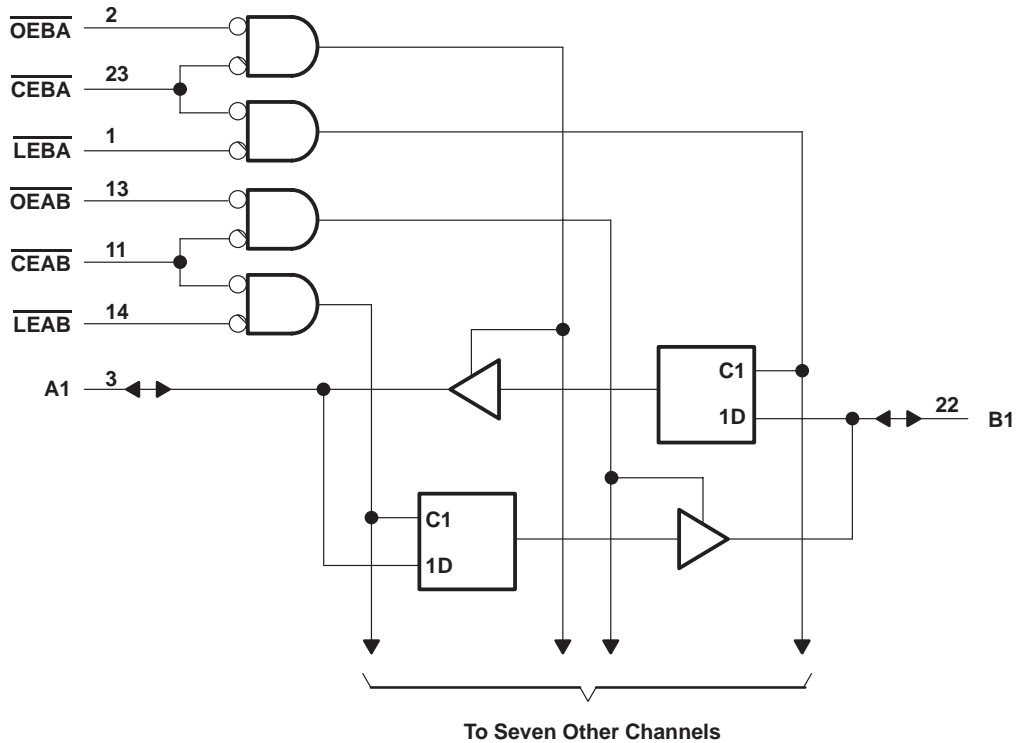

**SN74F543**  
**OCTAL REGISTERED TRANSCEIVER**  
**WITH 3-STATE OUTPUTS**

SDFS025B – D2942, MARCH 1987 – REVISED OCTOBER 1993

**absolute maximum ratings over operating free-air temperature range (unless otherwise noted)†**

Supply voltage range, $V_{CC}$ .....	–0.5 V to 7 V
Input voltage range, $V_I$ (excluding I/O ports) (see Note 1) .....	–1.2 V to 7 V
Input current range, $I_{IK}$ .....	–30 mA to 5 mA
Voltage range applied to any output in the disabled or power-off state .....	–0.5 V to 5.5 V
Voltage range applied to any output in the high state .....	–0.5 V to $V_{CC}$
Current into any output in the low state: A1–A8 .....	48 mA
B1–B8 .....	128 mA
Operating free-air temperature range .....	0°C to 70°C
Storage temperature range .....	–65°C to 150°C

† Stresses beyond those listed under “absolute maximum ratings” may cause permanent damage to the device. These are stress ratings only, and functional operation of the device at these or any other conditions beyond those indicated under “recommended operating conditions” is not implied. Exposure to absolute-maximum-rated conditions for extended periods may affect device reliability.

NOTE 1: The input-voltage ratings may be exceeded provided the input-current ratings are observed.

**recommended operating conditions**

		MIN	NOM	MAX	UNIT
$V_{CC}$	Supply voltage	4.5	5	5.5	V
$V_{IH}$	High-level input voltage	2			V
$V_{IL}$	Low-level input voltage			0.8	V
$I_{IK}$	Input clamp current			–18	mA
$I_{OH}$	High-level output current	A1–A8		–3	mA
		B1–B8		–15	
$I_{OL}$	Low-level output current	A1–A8		24	mA
		B1–B8		64	
$T_A$	Operating free-air temperature	0		70	°C



# SN74F543

## OCTAL REGISTERED TRANSCEIVER WITH 3-STATE OUTPUTS

SDFS025B – D2942, MARCH 1987 – REVISED OCTOBER 1993

electrical characteristics over recommended operating free-air temperature range (unless otherwise noted)

PARAMETER		TEST CONDITIONS		MIN	TYP†	MAX	UNIT
$V_{IK}$		$V_{CC} = 4.5\text{ V}$ ,	$I_I = -18\text{ mA}$			-1.2	V
$V_{OH}$	A1–A8	$V_{CC} = 4.5\text{ V}$	$I_{OH} = -1\text{ mA}$	2.5	3.4		V
			$I_{OH} = -3\text{ mA}$	2.4	3.3		
	B1–B8		$I_{OH} = -3\text{ mA}$	2.4	3.3		
			$I_{OH} = -15\text{ mA}$	2	3.1		
Any output		$V_{CC} = 4.75\text{ V}$ ,	$I_{OH} = -1\text{ mA to } -3\text{ mA}$	2.7			
$V_{OL}$	A1–A8	$V_{CC} = 4.5\text{ V}$	$I_{OL} = 24\text{ mA}$		0.3	0.5	V
	B1–B8		$I_{OL} = 64\text{ mA}$		0.42	0.55	
$I_I$	$\overline{OE}$ , $\overline{LE}$ , and $\overline{CE}$	$V_{CC} = 5.5\text{ V}$	$V_I = 7\text{ V}$			0.1	mA
	A and B ports		$V_I = 5.5\text{ V}$			1	
$I_{IH}‡$	$\overline{OE}$ , $\overline{LE}$ , and $\overline{CE}$	$V_{CC} = 5.5\text{ V}$ ,	$V_I = 2.7\text{ V}$			20	$\mu\text{A}$
	A and B ports					70	
$I_{IL}‡$	$\overline{OE}$ , $\overline{LE}$ , and $\overline{CE}$	$V_{CC} = 5.5\text{ V}$ ,	$V_I = 0.5\text{ V}$			-1.2	mA
	A and B ports					-0.65	
$I_{OS}§$	A1–A8	$V_{CC} = 5.5\text{ V}$ ,	$V_O = 0$			-60	mA
	B1–B8					-100	
$I_{CCH}$		$V_{CC} = 5.5\text{ V}$			67	100	mA
$I_{CCL}$		$V_{CC} = 5.5\text{ V}$			83	125	mA
$I_{CCZ}$		$V_{CC} = 5.5\text{ V}$			83	125	mA

† All typical values are at  $V_{CC} = 5\text{ V}$ ,  $T_A = 25^\circ\text{C}$ .

‡ For I/O ports, the parameters  $I_{IH}$  and  $I_{IL}$  include the off-state output current.

§ Not more than one output should be shorted at a time, and the duration of the short circuit should not exceed one second.

### timing requirements

		$V_{CC} = 5\text{ V}$ , $T_A = 25^\circ\text{C}$		$V_{CC} = 4.5\text{ V to } 5.5\text{ V}$ , $T_A = \text{MIN to MAX}¶$		UNIT
		MIN	MAX	MIN	MAX	
$t_w$	Pulse duration	5		5		ns
$t_{su}$	Setup time, data before latch enable		High or low	3	3.5	ns
$t_h$	Hold time, data after latch enable		High or low	3	3.5	ns

¶ For conditions shown as MIN or MAX, use the appropriate value specified under recommended operating conditions.

**SN74F543**  
**OCTAL REGISTERED TRANSCEIVER**  
**WITH 3-STATE OUTPUTS**

SDFS025B – D2942, MARCH 1987 – REVISED OCTOBER 1993

**switching characteristics (see Note 2)**

PARAMETER	FROM (INPUT)	TO (OUTPUT)	V <sub>CC</sub> = 5 V, C <sub>L</sub> = 50 pF, R <sub>L</sub> = 500 Ω, T <sub>A</sub> = 25°C			V <sub>CC</sub> = 4.5 V to 5.5 V, C <sub>L</sub> = 50 pF, R <sub>L</sub> = 500 Ω, T <sub>A</sub> = MIN to MAX†		UNIT
			MIN	TYP	MAX	MIN	MAX	
t <sub>PLH</sub>	A or B	B or A	2.2	5.1	7.5	2.2	8.5	ns
t <sub>PHL</sub>			2.2	4.6	6.5	2.2	7.5	
t <sub>PLH</sub>	$\overline{LEBA}$	A	3.7	8.1	11	4.1	12.5	ns
t <sub>PHL</sub>			3.7	8.1	11	4.1	12.5	
t <sub>PLH</sub>	$\overline{LEAB}$	B	3.7	8.1	11	4.1	12.5	ns
t <sub>PHL</sub>			3.7	8.1	11	4.1	12.5	
t <sub>PZH</sub>	$\overline{OE}$ or $\overline{CE}$	A or B	2.2	6.6	9	2.2	10	ns
t <sub>PZL</sub>			3.2	7.1	10.5	3.2	12	
t <sub>PHZ</sub>	$\overline{OE}$ or $\overline{CE}$	A or B	1.7	5.6	8	1.7	9	ns
t <sub>PLZ</sub>			1.7	5.1	7.5	1.7	8.5	

† For conditions shown as MIN or MAX, use the appropriate value specified under recommended operating conditions.

NOTE 2: Load circuits and waveforms are shown in Section 1.



## PACKAGING INFORMATION

Orderable Device	Status (1)	Package Type	Package Drawing	Pins	Package Qty	Eco Plan (2)	Lead/Ball Finish (6)	MSL Peak Temp (3)	Op Temp (°C)	Device Marking (4/5)	Samples
SN74F543DBR	ACTIVE	SSOP	DB	24	2000	Green (RoHS & no Sb/Br)	CU NIPDAU	Level-1-260C-UNLIM	0 to 70	F543	<a href="#">Samples</a>
SN74F543DW	ACTIVE	SOIC	DW	24	25	Green (RoHS & no Sb/Br)	CU NIPDAU	Level-1-260C-UNLIM	0 to 70	F543	<a href="#">Samples</a>
SN74F543DWG4	ACTIVE	SOIC	DW	24	25	Green (RoHS & no Sb/Br)	CU NIPDAU	Level-1-260C-UNLIM	0 to 70	F543	<a href="#">Samples</a>
SN74F543DWR	ACTIVE	SOIC	DW	24	2000	Green (RoHS & no Sb/Br)	CU NIPDAU	Level-1-260C-UNLIM	0 to 70	F543	<a href="#">Samples</a>

(1) The marketing status values are defined as follows:

**ACTIVE:** Product device recommended for new designs.

**LIFEBUY:** TI has announced that the device will be discontinued, and a lifetime-buy period is in effect.

**NRND:** Not recommended for new designs. Device is in production to support existing customers, but TI does not recommend using this part in a new design.

**PREVIEW:** Device has been announced but is not in production. Samples may or may not be available.

**OBsolete:** TI has discontinued the production of the device.

(2) Eco Plan - The planned eco-friendly classification: Pb-Free (RoHS), Pb-Free (RoHS Exempt), or Green (RoHS & no Sb/Br) - please check <http://www.ti.com/productcontent> for the latest availability information and additional product content details.

**TBD:** The Pb-Free/Green conversion plan has not been defined.

**Pb-Free (RoHS):** TI's terms "Lead-Free" or "Pb-Free" mean semiconductor products that are compatible with the current RoHS requirements for all 6 substances, including the requirement that lead not exceed 0.1% by weight in homogeneous materials. Where designed to be soldered at high temperatures, TI Pb-Free products are suitable for use in specified lead-free processes.

**Pb-Free (RoHS Exempt):** This component has a RoHS exemption for either 1) lead-based flip-chip solder bumps used between the die and package, or 2) lead-based die adhesive used between the die and leadframe. The component is otherwise considered Pb-Free (RoHS compatible) as defined above.

**Green (RoHS & no Sb/Br):** TI defines "Green" to mean Pb-Free (RoHS compatible), and free of Bromine (Br) and Antimony (Sb) based flame retardants (Br or Sb do not exceed 0.1% by weight in homogeneous material)

(3) MSL, Peak Temp. - The Moisture Sensitivity Level rating according to the JEDEC industry standard classifications, and peak solder temperature.

(4) There may be additional marking, which relates to the logo, the lot trace code information, or the environmental category on the device.

(5) Multiple Device Markings will be inside parentheses. Only one Device Marking contained in parentheses and separated by a "~" will appear on a device. If a line is indented then it is a continuation of the previous line and the two combined represent the entire Device Marking for that device.

(6) Lead/Ball Finish - Orderable Devices may have multiple material finish options. Finish options are separated by a vertical ruled line. Lead/Ball Finish values may wrap to two lines if the finish value exceeds the maximum column width.

**Important Information and Disclaimer:**The information provided on this page represents TI's knowledge and belief as of the date that it is provided. TI bases its knowledge and belief on information provided by third parties, and makes no representation or warranty as to the accuracy of such information. Efforts are underway to better integrate information from third parties. TI has taken and continues to take reasonable steps to provide representative and accurate information but may not have conducted destructive testing or chemical analysis on incoming materials and chemicals. TI and TI suppliers consider certain information to be proprietary, and thus CAS numbers and other limited information may not be available for release.

In no event shall TI's liability arising out of such information exceed the total purchase price of the TI part(s) at issue in this document sold by TI to Customer on an annual basis.

**TAPE AND REEL INFORMATION**

**QUADRANT ASSIGNMENTS FOR PIN 1 ORIENTATION IN TAPE**

\*All dimensions are nominal

Device	Package Type	Package Drawing	Pins	SPQ	Reel Diameter (mm)	Reel Width W1 (mm)	A0 (mm)	B0 (mm)	K0 (mm)	P1 (mm)	W (mm)	Pin1 Quadrant
SN74F543DBR	SSOP	DB	24	2000	330.0	16.4	8.2	8.8	2.5	12.0	16.0	Q1
SN74F543DWR	SOIC	DW	24	2000	330.0	24.4	10.75	15.7	2.7	12.0	24.0	Q1

**TAPE AND REEL BOX DIMENSIONS**

\*All dimensions are nominal

Device	Package Type	Package Drawing	Pins	SPQ	Length (mm)	Width (mm)	Height (mm)
SN74F543DBR	SSOP	DB	24	2000	367.0	367.0	38.0
SN74F543DWR	SOIC	DW	24	2000	350.0	350.0	43.0

DW (R-PDSO-G24)

PLASTIC SMALL OUTLINE



- NOTES:
- All linear dimensions are in inches (millimeters). Dimensioning and tolerancing per ASME Y14.5M-1994.
  - This drawing is subject to change without notice.
  - Body dimensions do not include mold flash or protrusion not to exceed 0.006 (0,15).
  - Falls within JEDEC MS-013 variation AD.

DB (R-PDSO-G\*\*)

PLASTIC SMALL-OUTLINE

28 PINS SHOWN



- NOTES: A. All linear dimensions are in millimeters.  
 B. This drawing is subject to change without notice.  
 C. Body dimensions do not include mold flash or protrusion not to exceed 0,15.  
 D. Falls within JEDEC MO-150

## IMPORTANT NOTICE AND DISCLAIMER

TI PROVIDES TECHNICAL AND RELIABILITY DATA (INCLUDING DATASHEETS), DESIGN RESOURCES (INCLUDING REFERENCE DESIGNS), APPLICATION OR OTHER DESIGN ADVICE, WEB TOOLS, SAFETY INFORMATION, AND OTHER RESOURCES "AS IS" AND WITH ALL FAULTS, AND DISCLAIMS ALL WARRANTIES, EXPRESS AND IMPLIED, INCLUDING WITHOUT LIMITATION ANY IMPLIED WARRANTIES OF MERCHANTABILITY, FITNESS FOR A PARTICULAR PURPOSE OR NON-INFRINGEMENT OF THIRD PARTY INTELLECTUAL PROPERTY RIGHTS.

These resources are intended for skilled developers designing with TI products. You are solely responsible for (1) selecting the appropriate TI products for your application, (2) designing, validating and testing your application, and (3) ensuring your application meets applicable standards, and any other safety, security, or other requirements. These resources are subject to change without notice. TI grants you permission to use these resources only for development of an application that uses the TI products described in the resource. Other reproduction and display of these resources is prohibited. No license is granted to any other TI intellectual property right or to any third party intellectual property right. TI disclaims responsibility for, and you will fully indemnify TI and its representatives against, any claims, damages, costs, losses, and liabilities arising out of your use of these resources.

TI's products are provided subject to TI's Terms of Sale ([www.ti.com/legal/termsofsale.html](http://www.ti.com/legal/termsofsale.html)) or other applicable terms available either on [ti.com](http://ti.com) or provided in conjunction with such TI products. TI's provision of these resources does not expand or otherwise alter TI's applicable warranties or warranty disclaimers for TI products.

Mailing Address: Texas Instruments, Post Office Box 655303, Dallas, Texas 75265  
Copyright © 2019, Texas Instruments Incorporated

## Looking for pricing, stock, or lifecycle information?

Click below to explore more details on WIN SOURCE:

 [View 74F543NT](#) on WIN SOURCE

 [Texas Instruments](#) Information

## Optimize Your Supply Chain with WIN SOURCE Solutions

-  Global Sourcing Solution
-  Obsolete Management
-  Cost Control Management
-  Shortage Management
-  Alternative Solution
-  Excess Inventory Management