



**THE DATASHEET OF  
74F646SC**



# 74F646

## Octal Transceiver/Register with 3-STATE Outputs

### General Description

These devices consist of bus transceiver circuits with 3-STATE, D-type flip-flops, and control circuitry arranged for multiplexed transmission of data directly from the input bus or from the internal registers. Data on the A or B bus will be clocked into the registers as the appropriate clock pin goes to a high logic level. Control  $\bar{G}$  and direction pins are provided to control the transceiver function. In the transceiver mode, data present at the high impedance port may be stored in either the A or the B register or in both. The select controls can multiplex stored and real-time (transparent mode) data. The direction control determines which bus will receive data when the enable control  $\bar{G}$  is Active LOW. In the isolation mode (control  $\bar{G}$  HIGH), A data may be stored in the B register and/or B data may be stored in the A register.

### Features

- Independent registers for A and B buses
- Multiplexed real-time and stored data
- 74F646 has non-inverting data paths
- 3-STATE outputs
- 300 mil slim DIP

### Ordering Code:

Order Number	Package Number	Package Description
74F646SC	M24B	24-Lead Small Outline Integrated Circuit (SOIC), JEDEC MS-013, 0.300" Wide
74F646MSA	MSA24	24-Lead Shrink Small Outline Package (SSOP), JEDEC MO-150, 5.3mm Wide
74F646SPC	N24C	24-Lead Plastic Dual-In-Line Package (PDIP), JEDEC MS-001, 0.300" Wide

Devices also available in Tape and Reel. Specify by appending the suffix letter "X" to the ordering code.

### Logic Symbols

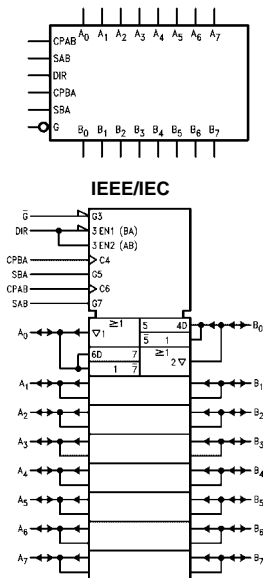

### Connection Diagram

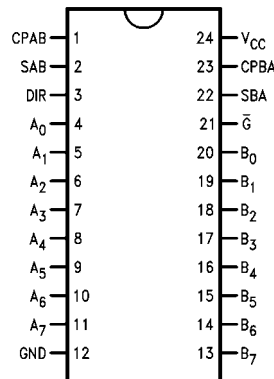

74F646 Octal Transceiver/Register with 3-STATE Outputs

### Unit Loading/Fan Out

Pin Names	Description	U.L. HIGH/LOW	Input $I_{IH}/I_{IL}$ Output $I_{OH}/I_{OL}$
A <sub>0</sub> -A <sub>7</sub>	Data Register A Inputs/ 3-STATE Outputs	3.5/1.083 600/106.6 (80)	70 $\mu$ A/-650 $\mu$ A -12 mA/64 mA (48 mA)
B <sub>0</sub> -B <sub>7</sub>	Data Register B Inputs/ 3-STATE Outputs	3.5/1.083 600/106.6 (80)	70 $\mu$ A/-650 $\mu$ A -12 mA/64 mA (48 mA)
CPAB, CPBA	Clock Pulse Inputs	1.0/1.0	20 $\mu$ A/-0.6 mA
SAB, SBA	Select Inputs	1.0/1.0	20 $\mu$ A/-0.6 mA
$\overline{G}$	Output Enable Input	1.0/1.0	20 $\mu$ A/-0.6 mA
DIR	Direction Control Input	1.0/1.0	20 $\mu$ A/-0.6 mA

### Function Table

Inputs						Data I/O (Note 1)		Function
$\overline{G}$	DIR	CPAB	CPBA	SAB	SBA	A <sub>0</sub> -A <sub>7</sub>	B <sub>0</sub> -B <sub>7</sub>	
H	X	H or L	H or L	X	X			Isolation
H	X	↗	X	X	X	Input	Input	Clock A <sub>n</sub> Data into A Register Clock B <sub>n</sub> Data into B Register
H	X	X	↗	X	X			
L	H	X	X	L	X			A <sub>n</sub> to B <sub>n</sub> —Real Time (Transparent Mode)
L	H	↗	X	L	X	Input	Output	Clock A <sub>n</sub> Data into A Register
L	H	H or L	X	H	X			A Register to B <sub>n</sub> (Stored Mode)
L	H	↗	X	H	X			Clock A <sub>n</sub> Data into A Register and Output to B <sub>n</sub>
L	L	X	X	X	L			B <sub>n</sub> to A <sub>n</sub> —Real Time (Transparent Mode)
L	L	X	↗	X	L	Output	Input	Clock B <sub>n</sub> Data into B Register
L	L	X	H or L	X	H			B Register to A <sub>n</sub> (Stored Mode)
L	L	X	↗	X	H			Clock B <sub>n</sub> Data into B Register and Output to A <sub>n</sub>

H = HIGH Voltage Level    L = LOW Voltage Level    X = Irrelevant    ↗ = LOW-to-HIGH Transition

**Note 1:** The data output functions may be enabled or disabled by various signals at the  $\overline{G}$  and DIR Inputs. Data input functions are always enabled; i.e., data at the bus pins will be stored on every LOW-to-HIGH transition of the clock inputs.

### Logic Diagram

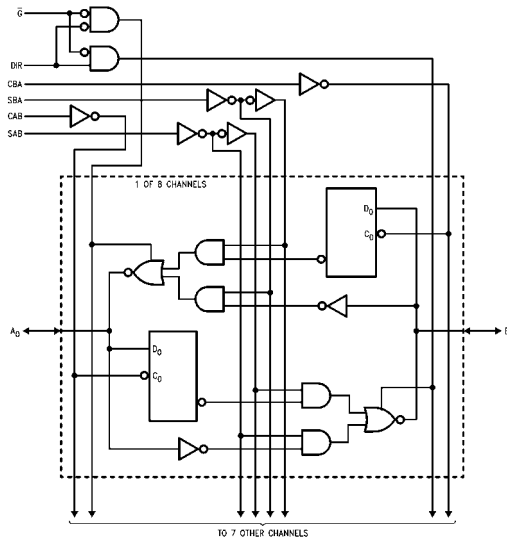

Please note that this diagram is provided only for the understanding of logic operations and should not be used to estimate propagation delays.

**Absolute Maximum Ratings**(Note 2)

Storage Temperature	-65°C to +150°C
Ambient Temperature under Bias	-55°C to +125°C
Junction Temperature under Bias	-55°C to +150°C
V <sub>CC</sub> Pin Potential to Ground Pin	-0.5V to +7.0V
Input Voltage (Note 3)	-0.5V to +7.0V
Input Current (Note 3)	-30 mA to +5.0 mA
Voltage Applied to Output in HIGH State (with V <sub>CC</sub> = 0V)	
Standard Output	-0.5V to V <sub>CC</sub>
3-STATE Output	-0.5V to +5.5V
Current Applied to Output in LOW State (Max)	twice the rated I <sub>OL</sub> (mA)
ESD Last Passing Voltage (Min)	4000V

**Recommended Operating Conditions**

Free Air Ambient Temperature	0°C to +70°C
Supply Voltage	+4.5V to +5.5V

**Note 2:** Absolute maximum ratings are values beyond which the device may be damaged or have its useful life impaired. Functional operation under these conditions is not implied.

**Note 3:** Either voltage limit or current limit is sufficient to protect inputs.

**DC Electrical Characteristics**

Symbol	Parameter	Min	Typ	Max	Units	V <sub>CC</sub>	Conditions
V <sub>IH</sub>	Input HIGH Voltage	2.0			V		Recognized as a HIGH Signal
V <sub>IL</sub>	Input LOW Voltage			0.8	V		Recognized as a LOW Signal
V <sub>CD</sub>	Input Clamp Diode Voltage			-1.2	V	Min	I <sub>IN</sub> = -18 mA (Non I/O Pins)
V <sub>OH</sub>	Output HIGH Voltage 10% V <sub>CC</sub>	2.0			V	Min	I <sub>OH</sub> = -15 mA (A <sub>n</sub> , B <sub>n</sub> )
V <sub>OL</sub>	Output LOW Voltage 10% V <sub>CC</sub>			0.55	V	Min	I <sub>OL</sub> = 64 mA (A <sub>n</sub> , B <sub>n</sub> )
I <sub>IH</sub>	Input HIGH Current			5.0	μA	Max	V <sub>IN</sub> = 2.7V (Non I/O Pins)
I <sub>BVI</sub>	Input HIGH Current Breakdown Test			7.0	μA	Max	V <sub>IN</sub> = 7.0V (Non I/O Pins)
I <sub>BVIT</sub>	Input HIGH Current Breakdown (I/O)			0.5	mA	Max	V <sub>IN</sub> = 5.5V (A <sub>n</sub> , B <sub>n</sub> )
I <sub>CEx</sub>	Output HIGH Leakage Current			50	μA	Max	V <sub>OUT</sub> = V <sub>CC</sub>
V <sub>ID</sub>	Input Leakage Test	4.75			V	0.0	I <sub>ID</sub> = 1.9 μA All Other Pins Grounded
I <sub>OD</sub>	Output Leakage Circuit Current			3.75	μA	0.0	V <sub>IOD</sub> = 150 mV All Other Pins Grounded
I <sub>IL</sub>	Input LOW Current			-0.6	mA	Max	V <sub>IN</sub> = 0.5V (Non I/O Pins)
I <sub>IH</sub> + I <sub>OZH</sub>	Output Leakage Current			70	μA	Max	V <sub>OUT</sub> = 2.7V (A <sub>n</sub> , B <sub>n</sub> )
I <sub>IL</sub> + I <sub>OZL</sub>	Output Leakage Current			-650	μA	Max	V <sub>OUT</sub> = 0.5V (A <sub>n</sub> , B <sub>n</sub> )
I <sub>OS</sub>	Output Short-Circuit Current	-100		-225	mA	Max	V <sub>OUT</sub> = 0V
I <sub>ZZ</sub>	Bus Drainage Test			500	μA	0.0V	V <sub>OUT</sub> = 5.25V
I <sub>CCH</sub>	Power Supply Current			135	mA	Max	V <sub>O</sub> = HIGH
I <sub>CCL</sub>	Power Supply Current			150	mA	Max	V <sub>O</sub> = LOW
I <sub>CCZ</sub>	Power Supply Current			150	mA	Max	V <sub>O</sub> = HIGH Z

### AC Electrical Characteristics

Symbol	Parameter	$T_A = +25^\circ\text{C}$		$T_A = -55^\circ\text{C to } +125^\circ\text{C}$		$T_A = 0^\circ\text{C to } +70^\circ\text{C}$		Units
		$V_{CC} = +5.0\text{V}$		$V_{CC} = +5.0\text{V}$		$V_{CC} = +5.0\text{V}$		
		$C_L = 50\text{ pF}$		$C_L = 50\text{ pF}$		$C_L = 50\text{ pF}$		
		Min	Max	Min	Max	Min	Max	
$f_{MAX}$	Maximum Clock Frequency	90		75		90		MHz
$t_{PLH}$	Propagation Delay	2.0	7.0	2.0	8.5	2.0	8.0	ns
$t_{PHL}$	Clock to Bus	2.0	8.0	2.0	9.5	2.0	9.0	
$t_{PLH}$	Propagation Delay	1.0	7.0	1.0	8.0	1.0	7.5	ns
$t_{PHL}$	Bus to Bus	1.0	6.5	1.0	8.0	1.0	7.0	
$t_{PLH}$	Propagation Delay	2.0	8.5	2.0	11.0	2.0	9.5	ns
$t_{PHL}$	SBA or SAB to A or B	2.0	8.0	2.0	10.0	2.0	9.0	
$t_{PZH}$	Enable Time	2.0	8.5	2.0	10.0	2.0	9.0	ns
$t_{PZL}$	OE to A or B	2.0	12.0	2.0	13.5	2.0	12.5	
$t_{PHZ}$	Disable Time	1.0	7.5	1.0	9.0	1.0	8.5	ns
$t_{PLZ}$	$\overline{\text{OE}}$ to A or B	2.0	9.0	2.0	11.0	2.0	9.5	
$t_{PZH}$	Enable Time	2.0	14.0	2.0	16.0	2.0	15.0	ns
$t_{PZL}$	DIR to A or B	2.0	13.0	2.0	15.0	2.0	14.0	
$t_{PHZ}$	Disable Time	1.0	9.0	1.0	10.0	1.0	9.5	ns
$t_{PLZ}$	DIR to A or B	2.0	11.0	2.0	12.0	2.0	11.5	

### AC Operating Requirements

Symbol	Parameter	$T_A = +25^\circ\text{C}$		$T_A = -55^\circ\text{C to } +125^\circ\text{C}$		$T_A = 0^\circ\text{C to } +70^\circ\text{C}$		Units
		$V_{CC} = +5.0\text{V}$		$V_{CC} = +5.0\text{V}$		$V_{CC} = +5.0\text{V}$		
		Min	Max	Min	Max	Min	Max	
$t_S(H)$	Setup Time, HIGH or LOW	5.0		5.0		5.0		ns
$t_S(L)$	Bus to Clock	5.0		5.0		5.0		
$t_H(H)$	Hold Time, HIGH or LOW	2.0		2.5		2.0		ns
$t_H(L)$	Bus to Clock	2.0		2.5		2.0		
$t_W(H)$	Clock Pulse Width	5.0		5.0		5.0		ns
$t_W(L)$	HIGH or LOW	5.0		5.0		5.0		

**Physical Dimensions** inches (millimeters) unless otherwise noted

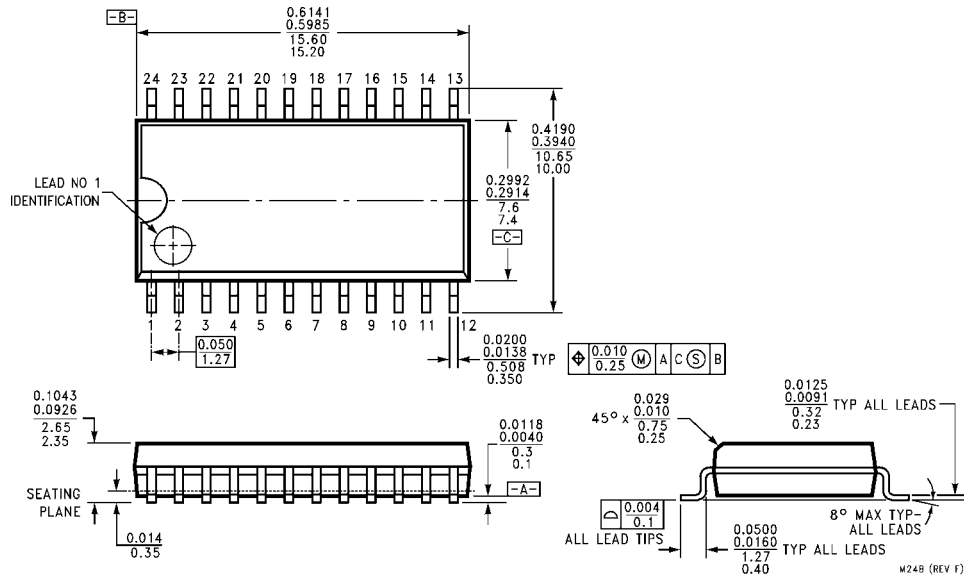

**24-Lead Small Outline Integrated Circuit (SOIC), JEDEC MS-013, 0.300" Wide Package Number M24B**

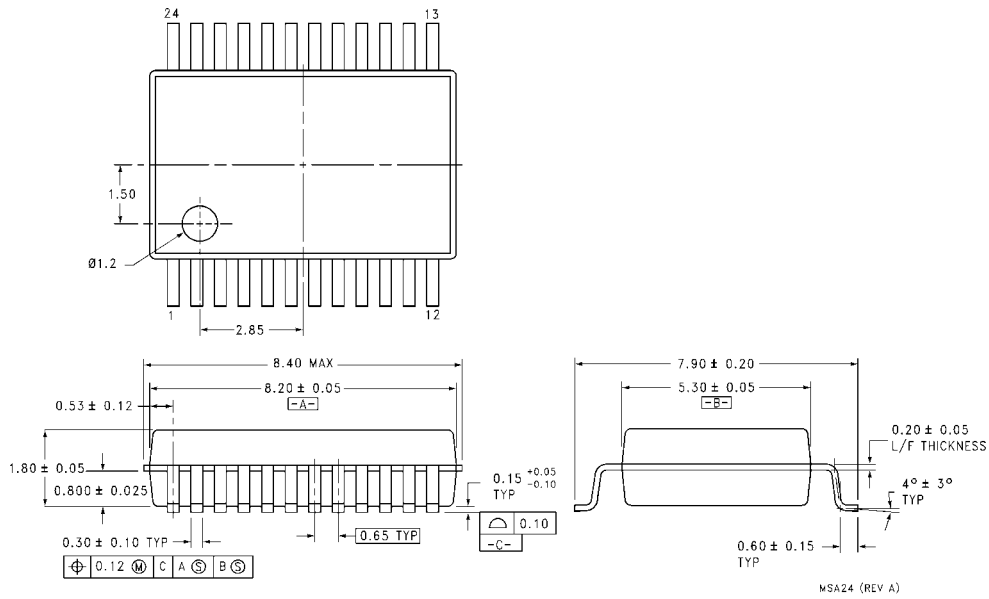

**24-Lead Shrink Small Outline Package (SSOP), JEDEC MO-150, 5.3mm Wide Package Number MSA24**

**Physical Dimensions** inches (millimeters) unless otherwise noted (Continued)

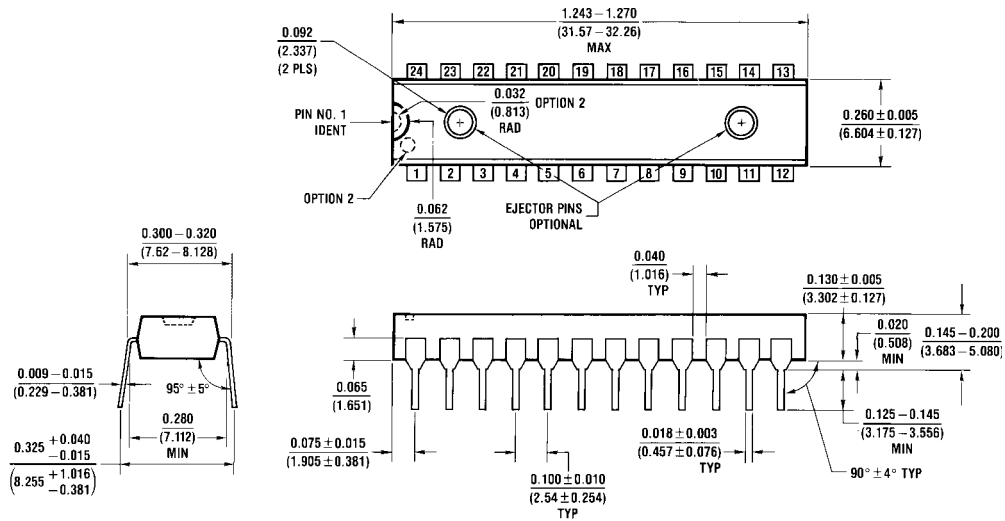

N24C (REV F)

**24-Lead Plastic Dual-In-Line Package (PDIP), JEDEC MS-001, 0.300" Wide  
Package Number N24C**

Fairchild does not assume any responsibility for use of any circuitry described, no circuit patent licenses are implied and Fairchild reserves the right at any time without notice to change said circuitry and specifications.

**LIFE SUPPORT POLICY**

FAIRCHILD'S PRODUCTS ARE NOT AUTHORIZED FOR USE AS CRITICAL COMPONENTS IN LIFE SUPPORT DEVICES OR SYSTEMS WITHOUT THE EXPRESS WRITTEN APPROVAL OF THE PRESIDENT OF FAIRCHILD SEMICONDUCTOR CORPORATION. As used herein:

1. Life support devices or systems are devices or systems which, (a) are intended for surgical implant into the body, or (b) support or sustain life, and (c) whose failure to perform when properly used in accordance with instructions for use provided in the labeling, can be reasonably expected to result in a significant injury to the user.
2. A critical component in any component of a life support device or system whose failure to perform can be reasonably expected to cause the failure of the life support device or system, or to affect its safety or effectiveness.

[www.fairchildsemi.com](http://www.fairchildsemi.com)

## Looking for pricing, stock, or lifecycle information?

Click below to explore more details on WIN SOURCE:

- ⊖ [View 74F646SC on WIN SOURCE](#)
- ⊖ [Fairchild/ON Semiconductor Information](#)

## Optimize Your Supply Chain with WIN SOURCE Solutions

- ✓ Global Sourcing Solution
- ✓ Obsolete Management
- ✓ Cost Control Management
- ✓ Shortage Management
- ✓ Alternative Solution
- ✓ Excess Inventory Management