



**THE DATASHEET OF
SN105125DBVR**



features

- Low Dropout Voltage Regulator, 1.2-V
- 150-mA Load Current Capability
- Power Okay (POK) Function
- Load Independent, Low Ground Current, 150- μ A
- Current Limiting
- Thermal Shutdown
- Low Sleep State Current (Off Mode)
- Fast Transient Response
- Low Variation Due to Load and Line Regulation
- Output Stable With Low ESR Capacitors
- TTL Logic Controlled Enable Input

applications

- Processor Powerup Sequencing
- Palmtop Computers, Laptops, and Notebooks

description

The SN105125 is a low dropout voltage regulator with an output tolerance of $\pm 2\%$ over the operating range. The device is optimized for low noise applications and has a low quiescent current (enable < 0.8 V). The device has a low dropout voltage at full load (150 mA). The power okay function monitors the output voltage and indicates when an error occurs in the system (active low). In the event of an output fault such as overcurrent, thermal shutdown, or dropout, the power okay output is pulled low (open drain).

The SN105125 has a fast transient response recovery capability in the event of load transition from heavy load to light load. The device also minimizes overshoot during this condition. During power down, the output capacitor and load are de-energized through the internal active shutdown clamp, which is turned on when the device is disabled.

The SN105125 requires a small output capacitor for stability with low ESR. An input capacitor is not required unless the bulk ac capacitor is placed away from the device or the power supply is a battery. In this situation, a 1- μ F capacitor is recommended for the application. Low ESR ceramic capacitors may be used with the device to reduce board space in power applications, a key concern in hand-held wireless devices.

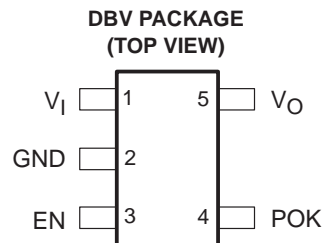

Please be aware that an important notice concerning availability, standard warranty, and use in critical applications of Texas Instruments semiconductor products and disclaimers thereto appears at the end of this data sheet.

PRODUCTION DATA information is current as of publication date. Products conform to specifications per the terms of Texas Instruments standard warranty. Production processing does not necessarily include testing of all parameters.

 **TEXAS
INSTRUMENTS**

POST OFFICE BOX 655303 • DALLAS, TEXAS 75265

Copyright © 2002, Texas Instruments Incorporated

SN105125 150-mA LOW DROPOUT REGULATOR WITH POK

SLVS418 – JANUARY 2002

functional block diagram

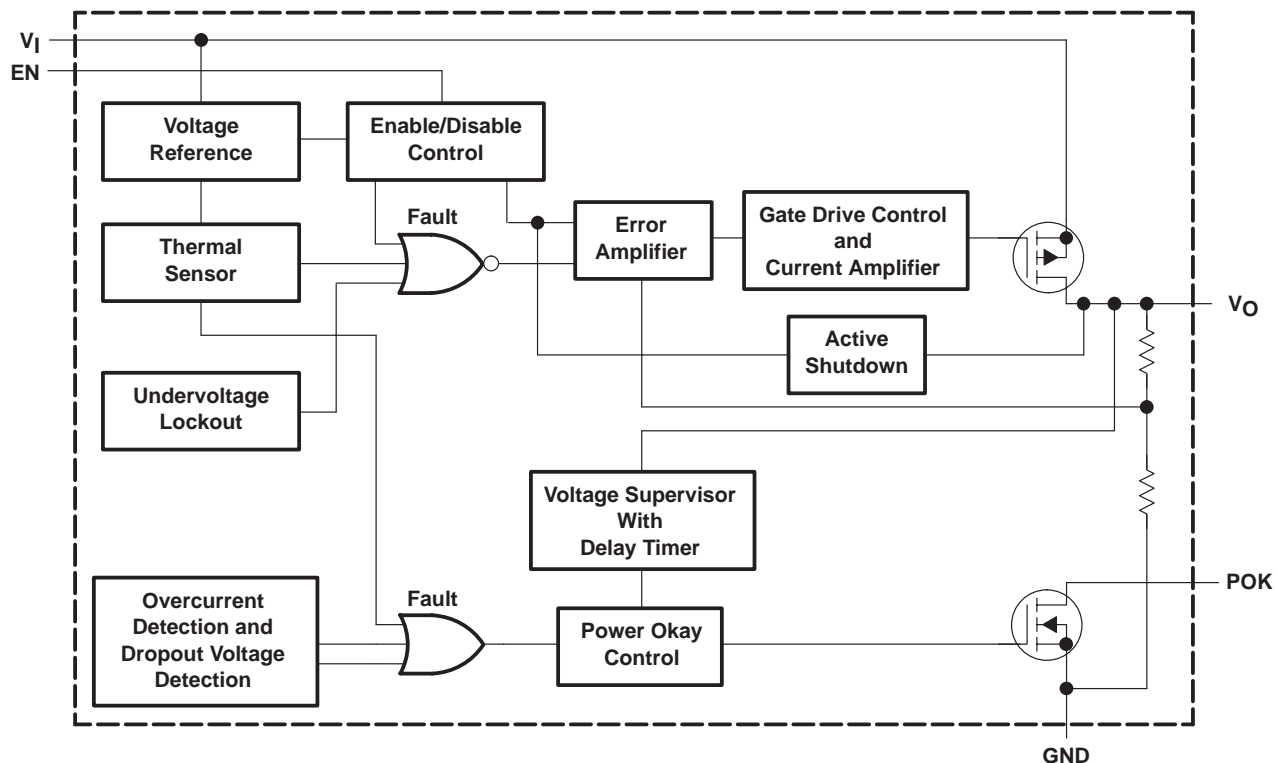

Terminal Functions

TERMINAL NAME	NO.	I/O	DESCRIPTION
EN	3	I	Enable/shutdown input (active high)
GND	2	I	Ground
POK	4	I	Power okay indicator
V _I	1	I	Input supply voltage
V _O	5	O	Output voltage

absolute maximum ratings over operating free-air temperature (unless otherwise noted)†

Main input voltage range, V_I (see Notes 1 and 2)	0 V to 7 V
Enable input voltage range, $V_{(EN)}$ (see Notes 1 and 2)	0 V – V_I
Power okay output voltage range $V_{(POK)}$, (see Notes 1 and 2)	0 V – V_I
Regulated output current limit, I_O	400 mA
Continuous power dissipation, P_D , $T_A = 25^\circ\text{C}$	0.5 W
Electrostatic discharge susceptibility, $V_{(HBMESD)}$, (see Note 3)	2 kV
Junction temperature, T_J ,	150°C
Storage temperature range, T_{Stg}	–55°C to 150°C
Lead temperature (soldering, 10 sec)	260°C

† Stresses beyond those listed under “absolute maximum ratings” may cause permanent damage to the device. These are stress ratings only, and functional operation of the device at these or any other conditions beyond those indicated under “recommended operating conditions” is not implied. Exposure to absolute-maximum-rated conditions for extended periods may affect device reliability.

- NOTES: 1. All voltage values are with respect to GND.
 2. Absolute negative voltage on these terminals should not go below –0.5 V.
 3. The human body model is a 100-pF capacitor discharged through a 1.5-kΩ resistor into each terminal. Devices are ESD sensitive. Handling precautions are recommended.

recommended operating conditions

	MIN	TYP	MAX	UNIT
Main input voltage, V_I (see Notes 1 and 2)	3		5.25	V
Enable input voltage, $V_{(EN)}$ (see Notes 1 and 2)	0		V_I	V
Power okay voltage, $V_{(POK)}$ (see Notes 1 and 2)	0		V_I	V
Operating ambient temperature, T_A	0		70	°C

- NOTES: 1. All voltage values are with respect to GND.
 2. Absolute negative voltage on these terminals should not go below –0.5 V.

SN105125

150-mA LOW DROPOUT REGULATOR WITH POK

SLVS418 – JANUARY 2002

electrical characteristics, $T_A = 25^\circ\text{C}$, $V_I = 5\text{ V}$, $V_{(EN)} = V_I$, $I_O = 100\ \mu\text{A}$, $C_L = 1\ \mu\text{F}$ (unless otherwise noted)

regulator V_O

PARAMETER		TEST CONDITIONS	MIN	TYP	MAX	UNITS
V_O	Output voltage	$I_O = 25\ \text{mA}$		1.2		V
	Output voltage accuracy	$I_O = 0$	-1%		1%	
		$I_O = 50\ \text{mA}$, $T_A = 0^\circ\text{C}$ to 70°C (see Note 4)	-2%		2%	
I_Q	Quiescent supply current	$V_{(EN)} \leq 0.8\ \text{V}$		1		μA
$I_{(GND)}$	Ground terminal current (see Note 5)	$I_O = 0$		150		μA
		$I_O = 150\ \text{mA}$		150		
I_L	Output load current		150			mA
$I_{(Limit)}$	Output current limit	$V_O = 0$	160	300		mA
$\Delta V_{(LNR)}$	Line regulation	$V_I = 3\ \text{V}$ to $5.25\ \text{V}$		10		mV
$\Delta V_{(LDR)}$	Load regulation	$I_O = 0.1\ \text{mA}$ to $150\ \text{mA}$, See Note 6		2%	3%	
$V_I - V_O$	Dropout voltage	$I_O = 100\ \mu\text{A}$		1		V
		$I_O = 150\ \text{mA}$		1		
C_L	Load capacitance	ESR and capacitance tradeoffs		1		μF
$I_{(REV)}$	Reverse output current on V_I	$V_I = \text{GND}$, $V_O = \text{regulated voltage}$			50	μA

- NOTES: 4. Assured by design, not tested in production.
 5. Ground terminal current is the regulator quiescent current drawn from the supply to support the load current.
 6. Regulation is measured at constant junction temperature using low duty cycle pulse testing. Devices are tested for load regulation in the load range from 0.1 mA to 150 mA.

enable input

PARAMETER		TEST CONDITIONS	MIN	TYP	MAX	UNITS
V_{IL}	Regulated shutdown	$V_I = 3\ \text{V}$ to $5.25\ \text{V}$ regulated shutdown			0.8	V
V_{IH}	Regulated enabled	$V_I = 3\ \text{V}$ to $5.25\ \text{V}$ regulated enabled	2			V
$I_{(EN)}$	Enable input current	Shutdown, $V_{IL} \leq 0.8\ \text{V}$		0.01		μA
		Enabled, $V_{IH} \geq 2\ \text{V}$		0.01		
	Resistance discharge	$V_{(EN)} \leq 0.8\ \text{V}$		500		Ω

thermal protection (see Note 4)

PARAMETER		TEST CONDITIONS	MIN	TYP	MAX	UNITS
$T_{(SD)}$	Thermal shutdown			165		$^\circ\text{C}$
$T_{(SDHYS)}$	Hysteresis			15		$^\circ\text{C}$

NOTE 4: Assured by design, not tested in production.

power okay (see Note 7)

PARAMETER		TEST CONDITIONS	MIN	TYP	MAX	UNITS
$V_{(POKLO)}$	Low threshold	Output falls % of V_O (power NOT okay)	85%			
$V_{(POKTH)}$	High threshold	Output reaches % of V_O , starts delay timer (power okay)			90%	
V_{OL}	V_O out of regulation	Fault condition, $I_{OL} = 100\ \mu\text{A}$			0.4	V
I_{lkg}	Leakage current	$V_I = 5\ \text{V}$			1	μA

NOTE 7: Power okay is a function of the output voltage being 5% lower than the specified range. The function is a detection of one of the following: over current, over temperature, or dropout.



SN105125

150-mA LOW DROPOUT REGULATOR WITH POK

SLVS418 – JANUARY 2002

switching characteristics (see Note 4), $T_A = 25^\circ\text{C}$, $V_I = 5\text{ V}$, $V_{(\text{EN})} = V_I$, $I_O = 100\ \mu\text{A}$, $C_L = 1\ \mu\text{F}$ (unless otherwise noted)

PARAMETER		TEST CONDITIONS	MIN	TYP	MAX	UNIT
	Power up overshoot	Maximum voltage overshoot allowed on output during powerup		1%		
$t_{(\text{STEP})}$	Output transient time limit	Time for output to return within specified regulation range		5		μs
	Output transient voltage limit	Voltage that load step can affect the nominal output voltage		1%		
$I_{(\text{SR})}$	Load step current slew rate	$I_L = 0.1\ \text{mA}$ to 150 mA		10		$\text{mA}/\mu\text{s}$
t_r	Power up rise time			50		μs
t_f	Power down fall time	Discharge resistance = 500 Ω , $V_O < 1.08\ \text{V}$		60		μs
$t_d(\text{POK})$	Power okay delay time	$V_I > V_{(\text{POKTH})}$ until $\text{POK}\uparrow$		2.5		ms

NOTE 4: Assured by design, not tested in production.

thermal resistance

PARAMETER		TEST CONDITIONS	MIN	TYP	MAX	UNIT
$R_{\theta\text{JC}}$	Thermal impedance, junction-to-case			145		$^\circ\text{C}/\text{W}$
$R_{\theta\text{JA}}$	Thermal impedance, junction-to-ambient			235		$^\circ\text{C}/\text{W}$

SN105125 150-mA LOW DROPOUT REGULATOR WITH POK

SLVS418 – JANUARY 2002

PARAMETER MEASUREMENT INFORMATION

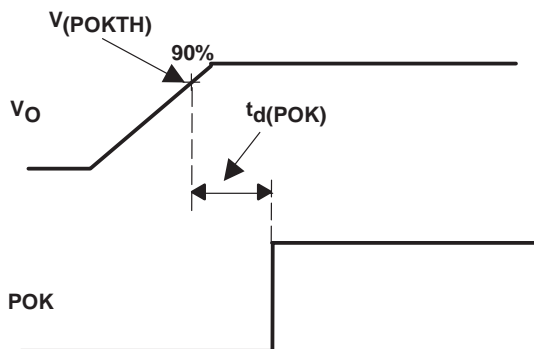

Figure 1. Power Okay Timing During Power Up

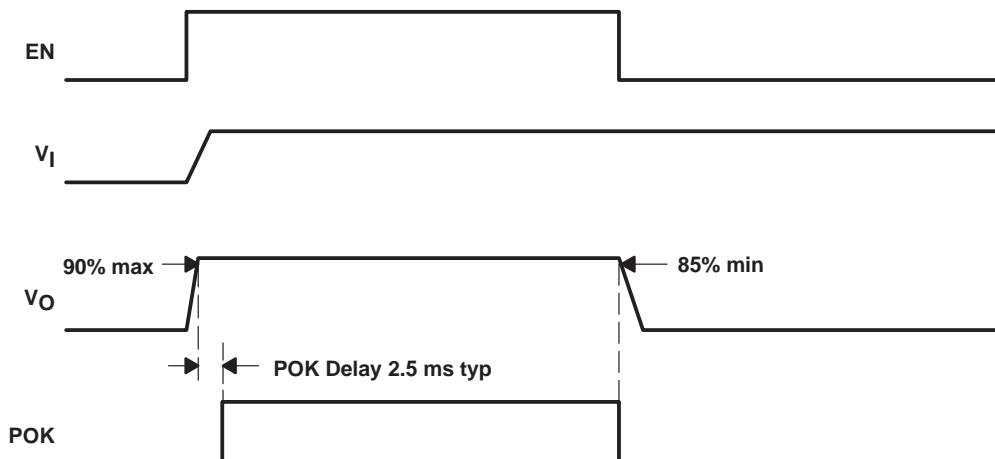

Figure 2. Power Okay Delay Timing and Output Voltage Supervisory

TYPICAL CHARACTERISTICS

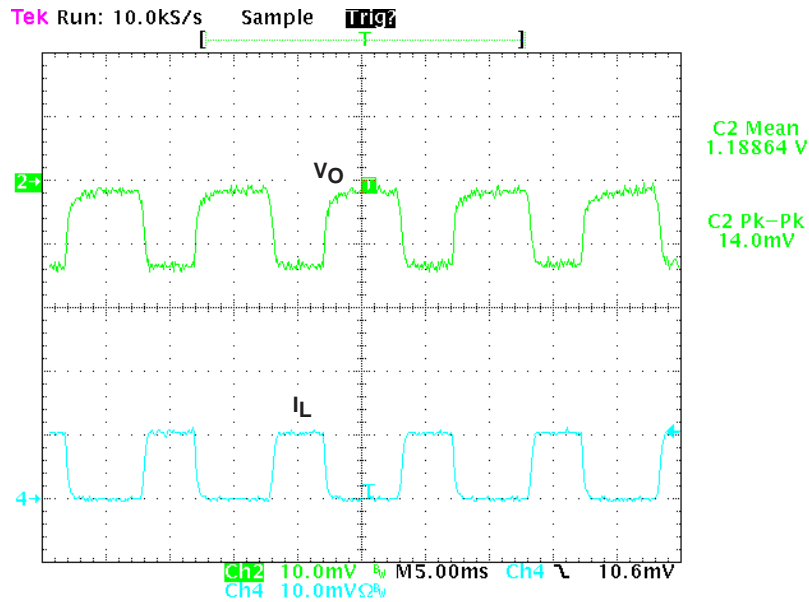

Figure 3. Load Regulation, 50-mA Dynamic Load Step ($V_I = 3\text{ V}$)

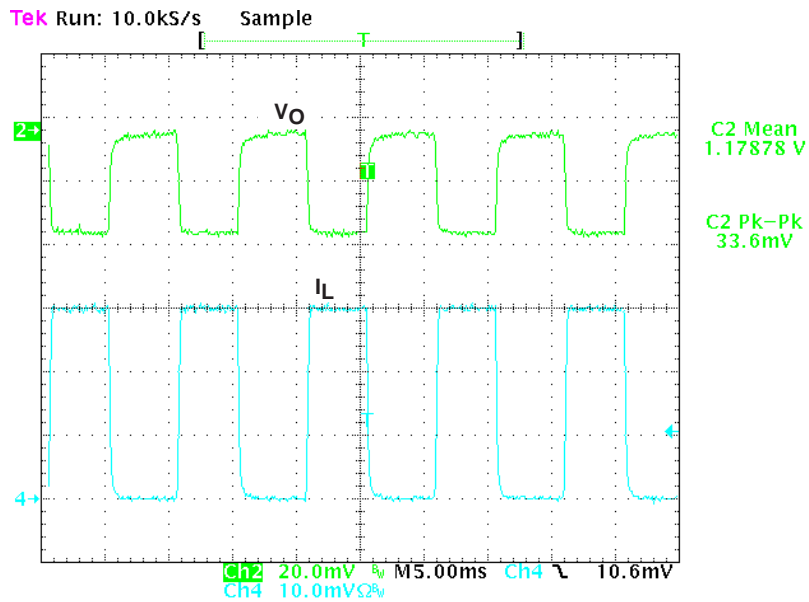

Figure 4. Load Regulation, 150-mA Dynamic Load Step ($V_I = 3\text{ V}$)

SN105125 150-mA LOW DROPOUT REGULATOR WITH POK

SLVS418 – JANUARY 2002

TYPICAL CHARACTERISTICS

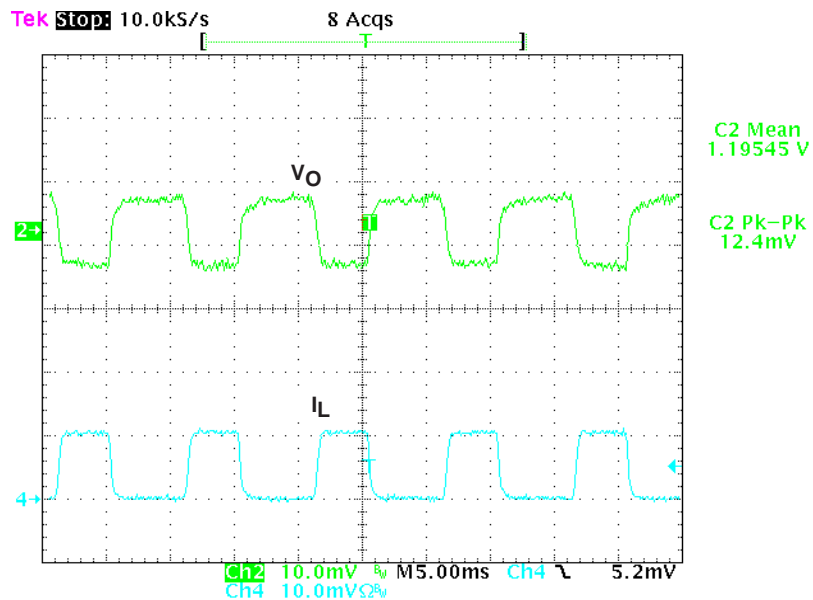

Figure 5. Load Regulation, 50-mA Dynamic Load Step ($V_I = 5\text{ V}$)

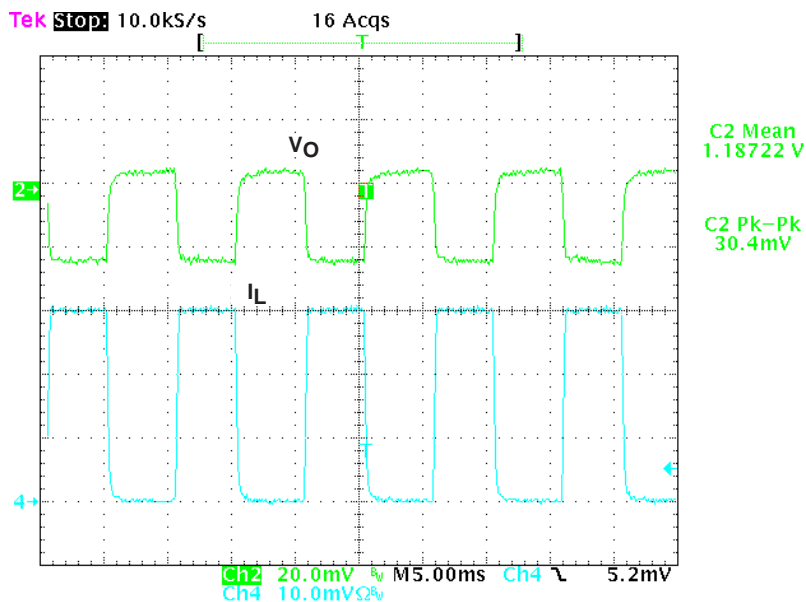

Figure 6. Load Regulation, 150-mA Dynamic Load Step ($V_I = 5\text{ V}$)

TYPICAL CHARACTERISTICS

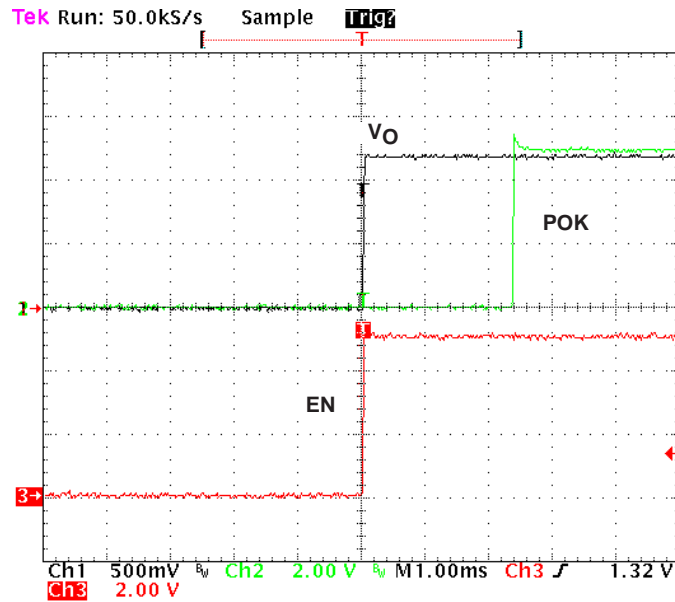

Figure 7. Power Okay Delay During Power Up Condition

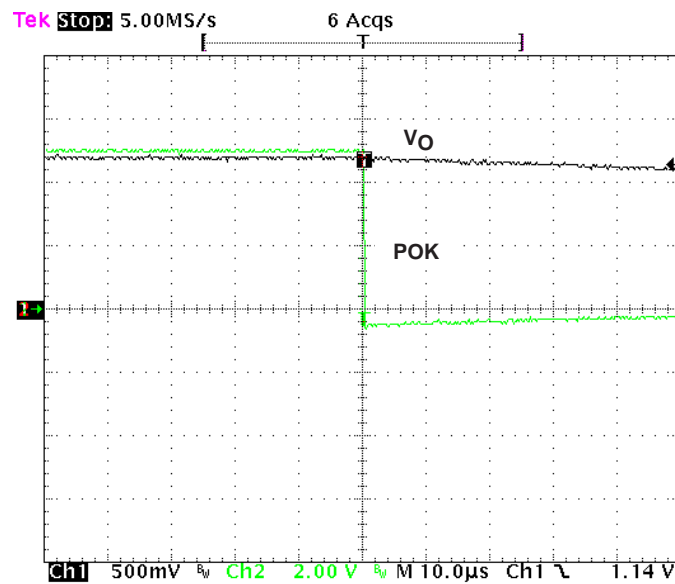

Figure 8. Power Okay Delay During Power Down Condition

SN105125

150-mA LOW DROPOUT REGULATOR WITH POK

SLVS418 – JANUARY 2002

THERMAL INFORMATION

The SN105125 is designed to provide a continuous load current of 150 mA when the maximum power dissipation of the package is not exceeded in the application. To determine the maximum power dissipation of the package, use the junction-to-ambient thermal resistance of the device. The basic equation is as follows:

Maximum power dissipation (W)

$$P_{D(MAX)} = (T_{J(MAX)} - T_A) / R_{\theta JA} \text{ (maximum power dissipation limit)}$$

Where:

$T_{J(MAX)}$ is the maximum junction temperature of the die (less than 150°C, minimum thermal shutdown)

T_A is the operating ambient temperature

$R_{\theta JA}$ is the thermal resistance and is layout dependent

The recommended minimum footprint offers a $R_{\theta JA}$ of 235°C/W.

To determine the actual power dissipation of the regulator, use the following equation:

$$P_D = (V_I - V_O) I_O + V_I I_{(GND)} \text{ (Watts)}$$

Power dissipation resulting from quiescent current is negligible. When the power dissipation is excessive, the thermal protection circuit is triggered.

APPLICATION INFORMATION

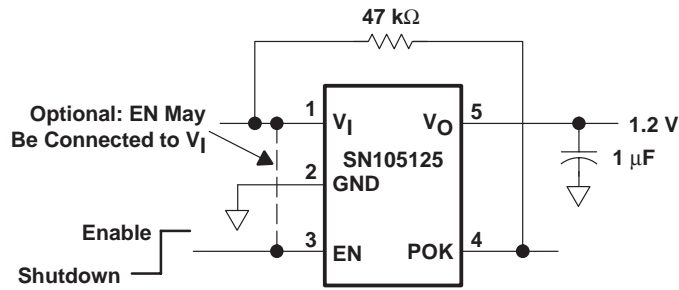

Figure 9. Typical Application Schematic

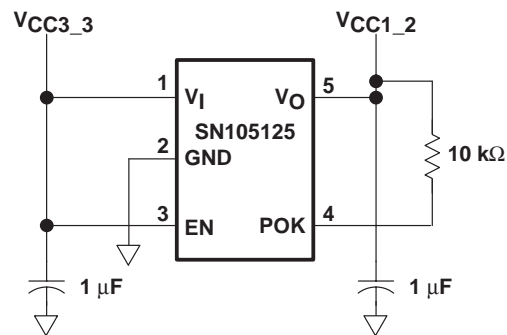

Figure 10. Typical Application For Processor VID Code Power Sequencing Schematic

PACKAGING INFORMATION

Orderable Device	Status (1)	Package Type	Package Drawing	Pins	Package Qty	Eco Plan (2)	Lead/Ball Finish (6)	MSL Peak Temp (3)	Op Temp (°C)	Device Marking (4/5)	Samples
SN105125DBVR	ACTIVE	SOT-23	DBV	5	3000	Green (RoHS & no Sb/Br)	CU NIPDAU	Level-1-260C-UNLIM	0 to 70	SBAI	Samples
SN105125DBVRG4	ACTIVE	SOT-23	DBV	5	3000	Green (RoHS & no Sb/Br)	CU NIPDAU	Level-1-260C-UNLIM	0 to 70	SBAI	Samples

(1) The marketing status values are defined as follows:

ACTIVE: Product device recommended for new designs.

LIFEBUY: TI has announced that the device will be discontinued, and a lifetime-buy period is in effect.

NRND: Not recommended for new designs. Device is in production to support existing customers, but TI does not recommend using this part in a new design.

PREVIEW: Device has been announced but is not in production. Samples may or may not be available.

OBSOLETE: TI has discontinued the production of the device.

(2) Eco Plan - The planned eco-friendly classification: Pb-Free (RoHS), Pb-Free (RoHS Exempt), or Green (RoHS & no Sb/Br) - please check <http://www.ti.com/productcontent> for the latest availability information and additional product content details.

TBD: The Pb-Free/Green conversion plan has not been defined.

Pb-Free (RoHS): TI's terms "Lead-Free" or "Pb-Free" mean semiconductor products that are compatible with the current RoHS requirements for all 6 substances, including the requirement that lead not exceed 0.1% by weight in homogeneous materials. Where designed to be soldered at high temperatures, TI Pb-Free products are suitable for use in specified lead-free processes.

Pb-Free (RoHS Exempt): This component has a RoHS exemption for either 1) lead-based flip-chip solder bumps used between the die and package, or 2) lead-based die adhesive used between the die and leadframe. The component is otherwise considered Pb-Free (RoHS compatible) as defined above.

Green (RoHS & no Sb/Br): TI defines "Green" to mean Pb-Free (RoHS compatible), and free of Bromine (Br) and Antimony (Sb) based flame retardants (Br or Sb do not exceed 0.1% by weight in homogeneous material)

(3) MSL, Peak Temp. - The Moisture Sensitivity Level rating according to the JEDEC industry standard classifications, and peak solder temperature.

(4) There may be additional marking, which relates to the logo, the lot trace code information, or the environmental category on the device.

(5) Multiple Device Markings will be inside parentheses. Only one Device Marking contained in parentheses and separated by a "~" will appear on a device. If a line is indented then it is a continuation of the previous line and the two combined represent the entire Device Marking for that device.

(6) Lead/Ball Finish - Orderable Devices may have multiple material finish options. Finish options are separated by a vertical ruled line. Lead/Ball Finish values may wrap to two lines if the finish value exceeds the maximum column width.

Important Information and Disclaimer: The information provided on this page represents TI's knowledge and belief as of the date that it is provided. TI bases its knowledge and belief on information provided by third parties, and makes no representation or warranty as to the accuracy of such information. Efforts are underway to better integrate information from third parties. TI has taken and continues to take reasonable steps to provide representative and accurate information but may not have conducted destructive testing or chemical analysis on incoming materials and chemicals. TI and TI suppliers consider certain information to be proprietary, and thus CAS numbers and other limited information may not be available for release.

In no event shall TI's liability arising out of such information exceed the total purchase price of the TI part(s) at issue in this document sold by TI to Customer on an annual basis.

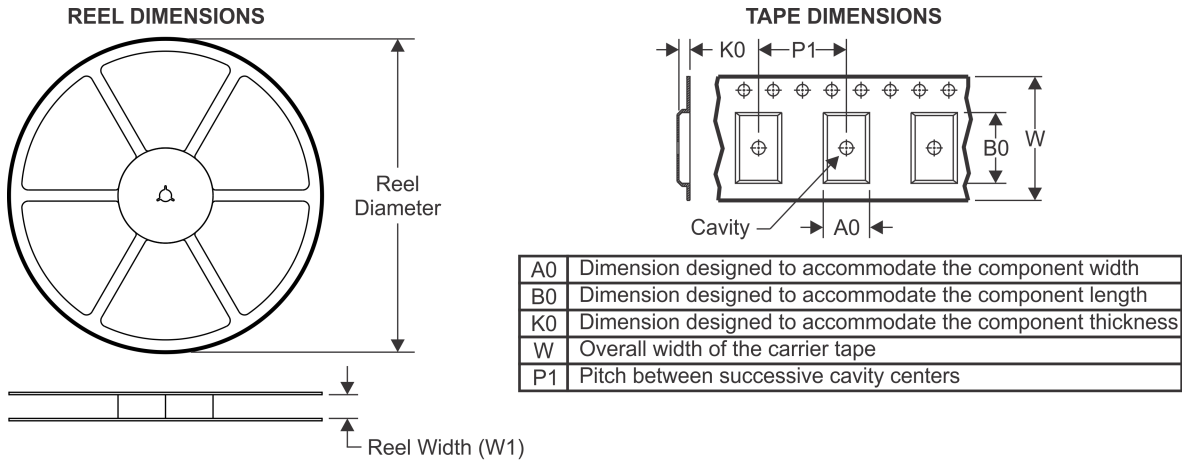
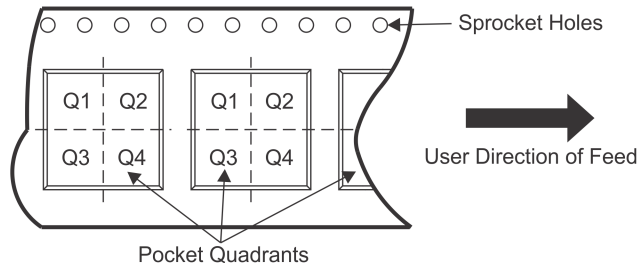
TAPE AND REEL INFORMATION

QUADRANT ASSIGNMENTS FOR PIN 1 ORIENTATION IN TAPE

*All dimensions are nominal

Device	Package Type	Package Drawing	Pins	SPQ	Reel Diameter (mm)	Reel Width W1 (mm)	A0 (mm)	B0 (mm)	K0 (mm)	P1 (mm)	W (mm)	Pin1 Quadrant
SN105125DBVR	SOT-23	DBV	5	3000	178.0	9.0	3.3	3.2	1.4	4.0	8.0	Q3

TAPE AND REEL BOX DIMENSIONS



*All dimensions are nominal

Device	Package Type	Package Drawing	Pins	SPQ	Length (mm)	Width (mm)	Height (mm)
SN105125DBVR	SOT-23	DBV	5	3000	180.0	180.0	18.0

IMPORTANT NOTICE

Texas Instruments Incorporated and its subsidiaries (TI) reserve the right to make corrections, enhancements, improvements and other changes to its semiconductor products and services per JESD46, latest issue, and to discontinue any product or service per JESD48, latest issue. Buyers should obtain the latest relevant information before placing orders and should verify that such information is current and complete. All semiconductor products (also referred to herein as "components") are sold subject to TI's terms and conditions of sale supplied at the time of order acknowledgment.

TI warrants performance of its components to the specifications applicable at the time of sale, in accordance with the warranty in TI's terms and conditions of sale of semiconductor products. Testing and other quality control techniques are used to the extent TI deems necessary to support this warranty. Except where mandated by applicable law, testing of all parameters of each component is not necessarily performed.

TI assumes no liability for applications assistance or the design of Buyers' products. Buyers are responsible for their products and applications using TI components. To minimize the risks associated with Buyers' products and applications, Buyers should provide adequate design and operating safeguards.

TI does not warrant or represent that any license, either express or implied, is granted under any patent right, copyright, mask work right, or other intellectual property right relating to any combination, machine, or process in which TI components or services are used. Information published by TI regarding third-party products or services does not constitute a license to use such products or services or a warranty or endorsement thereof. Use of such information may require a license from a third party under the patents or other intellectual property of the third party, or a license from TI under the patents or other intellectual property of TI.

Reproduction of significant portions of TI information in TI data books or data sheets is permissible only if reproduction is without alteration and is accompanied by all associated warranties, conditions, limitations, and notices. TI is not responsible or liable for such altered documentation. Information of third parties may be subject to additional restrictions.

Resale of TI components or services with statements different from or beyond the parameters stated by TI for that component or service voids all express and any implied warranties for the associated TI component or service and is an unfair and deceptive business practice. TI is not responsible or liable for any such statements.

Buyer acknowledges and agrees that it is solely responsible for compliance with all legal, regulatory and safety-related requirements concerning its products, and any use of TI components in its applications, notwithstanding any applications-related information or support that may be provided by TI. Buyer represents and agrees that it has all the necessary expertise to create and implement safeguards which anticipate dangerous consequences of failures, monitor failures and their consequences, lessen the likelihood of failures that might cause harm and take appropriate remedial actions. Buyer will fully indemnify TI and its representatives against any damages arising out of the use of any TI components in safety-critical applications.

In some cases, TI components may be promoted specifically to facilitate safety-related applications. With such components, TI's goal is to help enable customers to design and create their own end-product solutions that meet applicable functional safety standards and requirements. Nonetheless, such components are subject to these terms.

No TI components are authorized for use in FDA Class III (or similar life-critical medical equipment) unless authorized officers of the parties have executed a special agreement specifically governing such use.

Only those TI components which TI has specifically designated as military grade or "enhanced plastic" are designed and intended for use in military/aerospace applications or environments. Buyer acknowledges and agrees that any military or aerospace use of TI components which have **not** been so designated is solely at the Buyer's risk, and that Buyer is solely responsible for compliance with all legal and regulatory requirements in connection with such use.

TI has specifically designated certain components as meeting ISO/TS16949 requirements, mainly for automotive use. In any case of use of non-designated products, TI will not be responsible for any failure to meet ISO/TS16949.

Products

Audio	www.ti.com/audio
Amplifiers	amplifier.ti.com
Data Converters	dataconverter.ti.com
DLP® Products	www.dlp.com
DSP	dsp.ti.com
Clocks and Timers	www.ti.com/clocks
Interface	interface.ti.com
Logic	logic.ti.com
Power Mgmt	power.ti.com
Microcontrollers	microcontroller.ti.com
RFID	www.ti-rfid.com
OMAP Applications Processors	www.ti.com/omap
Wireless Connectivity	www.ti.com/wirelessconnectivity

Applications

Automotive and Transportation	www.ti.com/automotive
Communications and Telecom	www.ti.com/communications
Computers and Peripherals	www.ti.com/computers
Consumer Electronics	www.ti.com/consumer-apps
Energy and Lighting	www.ti.com/energy
Industrial	www.ti.com/industrial
Medical	www.ti.com/medical
Security	www.ti.com/security
Space, Avionics and Defense	www.ti.com/space-avionics-defense
Video and Imaging	www.ti.com/video

TI E2E Community

e2e.ti.com

Looking for pricing, stock, or lifecycle information?

Click below to explore more details on WIN SOURCE:

 [View SN105125DBVR on WIN SOURCE](#)

 [Texas Instruments](#) Information

Optimize Your Supply Chain with WIN SOURCE Solutions

-  Global Sourcing Solution
-  Obsolete Management
-  Cost Control Management
-  Shortage Management
-  Alternative Solution
-  Excess Inventory Management