



**THE DATASHEET OF
SN65HVD230DR**



SN65HVD23x 3.3-V CAN Bus Transceivers

1 Features

- Operates with a single 3.3 V Supply
- Compatible With ISO 11898-2 Standard
- Low Power Replacement for the PCA82C250 Footprint
- Bus Pin ESD Protection Exceeds ± 16 kV HBM
- High Input Impedance Allows for Up to 120 Nodes on a Bus
- Adjustable Driver Transition Times for Improved Emissions Performance
 - SN65HVD230 and SN65HVD231
- SN65HVD230: Low Current Standby Mode
 - 370 μ A Typical
- SN65HVD231: Ultra Low Current Sleep Mode
 - 40 nA Typical
- Designed for Data Rates⁽¹⁾ up to 1 Mbps
- Thermal Shutdown Protection
- Open Circuit Fail-Safe Design
- Glitch Free Power Up and Power Down Protection for Hot Plugging Applications

⁽¹⁾ The signaling rate of a line is the number of voltage transitions that are made per second expressed in the units bps (bits per second).

2 Applications

- Industrial Automation, Control, Sensors and Drive Systems
- Motor and Robotic Control
- Building and Climate Control (HVAC)
- Telecom and Basestation Control and Status
- CAN Bus Standards Such as CANopen, DeviceNet, and CAN Kingdom

3 Description

The SN65HVD230, SN65HVD231, and SN65HVD232 controller area network (CAN) transceivers are compatible to the specifications of the ISO 11898-2 High Speed CAN Physical Layer standard (transceiver). These devices are designed for data rates up to 1 megabit per second (Mbps), and include many protection features providing device and CAN network robustness. The SN65HVD23x transceivers are designed for use with the Texas Instruments 3.3 V μ Ps, MCUs and DSPs with CAN controllers, or with equivalent protocol controller devices. The devices are intended for use in applications employing the CAN serial communication physical layer in accordance with the ISO 11898 standard.

Device Information⁽¹⁾

PART NUMBER	PACKAGE	BODY SIZE (NOM)
SN65HVD230	SOIC (8)	4.90 mm x 3.91 mm
SN65HVD231		
SN65HVD232		

⁽¹⁾ For all available packages, see the orderable addendum at the end of the datasheet.

Equivalent Input and Output Schematic Diagrams

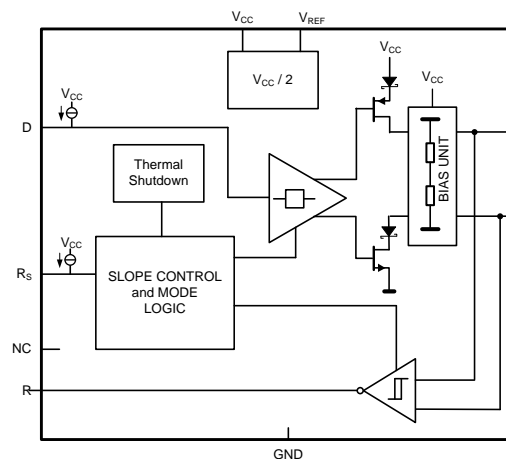

Table of Contents

1 Features	1	10.1 Overview	19
2 Applications	1	10.2 Functional Block Diagram	19
3 Description	1	10.3 Feature Description	20
4 Revision History	2	10.4 Device Functional Modes	20
5 Description (continued)	4	11 Application and Implementation	25
6 Device Comparison Table	4	11.1 Application Information	25
7 Pin Configuration and Functions	5	11.2 Typical Application	26
8 Specifications	5	11.3 System Example	30
8.1 Absolute Maximum Ratings	5	12 Power Supply Recommendations	32
8.2 ESD Ratings	6	13 Layout	33
8.3 Recommended Operating Conditions	6	13.1 Layout Guidelines	33
8.4 Thermal Information	6	13.2 Layout Example	34
8.5 Electrical Characteristics: Driver	7	14 Device and Documentation Support	35
8.6 Electrical Characteristics: Receiver	7	14.1 Related Links	35
8.7 Switching Characteristics: Driver	8	14.2 Receiving Notification of Documentation Updates	35
8.8 Switching Characteristics: Receiver	8	14.3 Community Resources	35
8.9 Switching Characteristics: Device	8	14.4 Trademarks	35
8.10 Device Control-Pin Characteristics	9	14.5 Electrostatic Discharge Caution	35
8.11 Typical Characteristics	10	14.6 Glossary	35
9 Parameter Measurement Information	13	15 Mechanical, Packaging, and Orderable Information	35
10 Detailed Description	19		

4 Revision History

NOTE: Page numbers for previous revisions may differ from page numbers in the current version.

Changes from Revision N (July 2015) to Revision O	Page
• Changed Slope Control Resistance - kW To: Slope Control Resistance - kΩ in Figure 33	22
• Changed Driver Output Signal Slope - V/ms To: Driver Output Signal Slope - V/μs in Figure 33	22

Changes from Revision M (May 2015) to Revision N	Page
• Changed the data sheet title From; SN65HVD230x 3.3-V CAN Bus Transceivers To: SN65HVD23x 3.3-V CAN Bus Transceivers	1

Changes from Revision L (January 2015) to Revision M	Page
• Changed Figure 44 title From: "Layout Example Schematic" To: "SN65HVD23x Board Layout"	34

Changes from Revision K (February 2011) to Revision L	Page
• Added <i>Pin Configuration and Functions</i> section, <i>ESD Ratings</i> table, <i>Feature Description</i> section, <i>Device Functional Modes</i> , <i>Application and Implementation</i> section, <i>Power Supply Recommendations</i> section, <i>Layout</i> section, <i>Device and Documentation Support</i> section, and <i>Mechanical, Packaging, and Orderable Information</i> section	1
• Changed the list of Features, Applications, and Description	1
• Added THERMAL SHUTDOWN TEMPERATURE AND HYSTERESIS in the Recommended Operating Conditions table	6
• Added the THERMAL SHUTDOWN paragraph to the Application Information section	20
• Added Figure 34 and Figure 35	25
• Added the CAN TERMINATION paragraph to the Application Information section	26
• Added the BUS LOADING, LENGTH AND NUMBER OF NODES paragraph to the Application Information section	28

Changes from Revision J (January 2009) to Revision K**Page**

- Replaced the DISSIPATION RATING TABLE with the Thermal Information table..... [6](#)
-

Changes from Revision I (October 2007) to Revision J**Page**

- Deleted Low-to-High Propagation Delay Time vs Common-Mode Input Voltage Characteristics [12](#)
 - Deleted Driver Schematic Diagram [12](#)
 - Added Figure 38 [32](#)
-

5 Description (continued)

Designed for operation in especially harsh environments, these devices feature cross wire protection, loss of ground and overvoltage protection, overtemperature protection, as well as wide common mode range of operation.

The CAN transceiver is the CAN physical layer and interfaces the single ended host CAN protocol controller with the differential CAN bus found in industrial, building automation, and automotive applications. These devices operate over a -2 V to 7 V common mode range on the bus, and can withstand common mode transients of ± 25 V.

The R_S pin (pin 8) on the SN65HVD230 and SN65HVD231 provides three different modes of operation: high speed mode, slope control mode, and low-power mode. The high speed mode of operation is selected by connecting the R_S pin to ground, allowing the transmitter output transistors to switch on and off as fast as possible with no limitation on the rise and fall slopes. The rise and fall slopes can also be adjusted by connecting a resistor in series between the R_S pin and ground. The slope will be proportional to the pin's output current. With a resistor value of 10 k Ω the device will have a slew rate of ~ 15 V/ μ s, and with a resistor value of 100 k Ω the device will have a slew rate of ~ 2 V/ μ s. See [Application Information](#) for more information.

The SN65HVD230 enters a low current standby mode (listen only) during which the driver is switched off and the receiver remains active if a high logic level is applied to the R_S pin. This mode provides a lower power consumption mode than normal mode while still allowing the CAN controller to monitor the bus for activity indicating it should return the transceiver to normal mode or slope control mode. The host controller (MCU, DSP) returns the device to a transmitting mode (high speed or slope control) when it wants to transmit a message to the bus or if during standby mode it received bus traffic indicating the need to once again be ready to transmit.

The difference between the SN65HVD230 and the SN65HVD231 is that both the driver and the receiver are switched off in the SN65HVD231 when a high logic level is applied to the R_S pin. In this sleep mode the device will not be able to transmit messages to the bus or receive messages from the bus. The device will remain in sleep mode until it is reactivated by applying a low logic level on the R_S pin.

6 Device Comparison Table

PART NUMBER ⁽¹⁾	LOW POWER MODE	INTEGRATED SLOPE CONTROL	V_{ref} PIN	T_A	MARKED AS:
SN65HVD230	Standby mode	Yes	Yes	40°C to 85°C	VP230
SN65HVD231	Sleep mode	Yes	Yes		VP231
SN65HVD232	No standby or sleep mode	No	No		VP232

(1) For the most current package and ordering information, see [Mechanical, Packaging, and Orderable Information](#), or see the TI web site at www.ti.com.

7 Pin Configuration and Functions

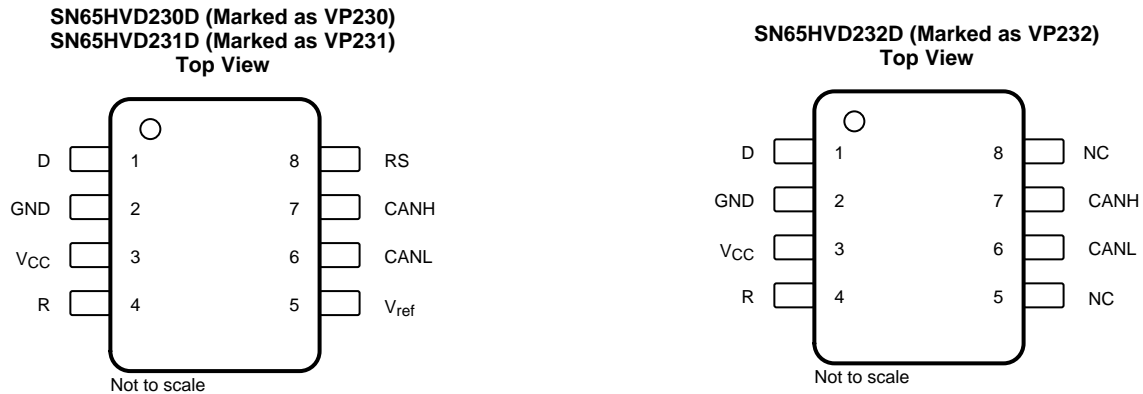

Pin Functions

PIN		TYPE	DESCRIPTION
NAME	NO.		
D	1	I	CAN transmit data input (LOW for dominant and HIGH for recessive bus states), also called TXD, driver input
GND	2	GND	Ground connection
V _{CC}	3	Supply	Transceiver 3.3V supply voltage
R	4	O	CAN receive data output (LOW for dominant and HIGH for recessive bus states), also called RXD, receiver output
V _{ref}	5	O	SN65HVD230 and SN65HVD231: V _{CC} / 2 reference output pin
NC		NC	SN65HVD232: No Connect
CANL	6	I/O	Low level CAN bus line
CANH	7	I/O	High level CAN bus line
R _S	8	I	SN65HVD230 and SN65HVD231: Mode select pin: strong pull down to GND = high speed mode, strong pull up to V _{CC} = low power mode, 10kΩ to 100kΩ pull down to GND = slope control mode
NC		I	SN65HVD232: No Connect

8 Specifications

8.1 Absolute Maximum Ratings

over operating free-air temperature range (unless otherwise noted)⁽¹⁾⁽²⁾

	MIN	MAX	UNIT
Supply voltage, V _{CC}	-0.3	6	V
Voltage at any bus terminal (CANH or CANL)	-4	16	V
Voltage input, transient pulse, CANH and CANL, through 100 Ω (see Figure 24)	-25	25	V
Digital Input and Output voltage, V _I (D or R)	-0.5	V _{CC} + 0.5	V
Receiver output current, I _O	-11	11	mA
Continuous total power dissipation	See Thermal Information		
Storage temperature, T _{stg}	-40	85	°C

- (1) Stresses beyond those listed under *Absolute Maximum Ratings* may cause permanent damage to the device. These are stress ratings only, and functional operation of the device at these or any other conditions beyond those indicated under *Recommended Operating Conditions* is not implied. Exposure to absolute-maximum-rated conditions for extended periods may affect device reliability.
- (2) All voltage values, except differential I/O bus voltages, are with respect to network ground terminal.

8.2 ESD Ratings

		VALUE	UNIT
$V_{(ESD)}$ Electrostatic discharge	Human body model (HBM), per ANSI/ESDA/JEDEC JS-001 ⁽¹⁾	CANH, CANL and GND	±16000
		All pins	±4000
	Charged-device model (CDM), per JEDEC specification JESD22-C101 ⁽²⁾		±1000

(1) JEDEC document JEP155 states that 500-V HBM allows safe manufacturing with a standard ESD control process.

(2) JEDEC document JEP157 states that 250-V CDM allows safe manufacturing with a standard ESD control process.

8.3 Recommended Operating Conditions

		MIN	NOM	MAX	UNIT
Supply voltage, V_{CC}			3	3.6	V
Voltage at any bus terminal (common mode) V_{IC}		–2 ⁽¹⁾		7	V
Voltage at any bus terminal (separately) V_I		–2.5		7.5	V
High-level input voltage, V_{IH}	D, R	2			V
Low-level input voltage, V_{IL}	D, R			0.8	V
Differential input voltage, V_{ID} (see Figure 22)		–6		6	V
Input voltage, $V_{(RS)}$			0	V_{CC}	V
Input voltage for standby or sleep, $V_{(RS)}$		0.75 V_{CC}		V_{CC}	V
Wave-shaping resistance, R_s			0	100	kΩ
High-level output current, I_{OH}	Driver	–40			mA
	Receiver	–8			
Low-level output current, I_{OL}	Driver			48	mA
	Receiver			8	
Thermal shutdown temperature			165		°C
Thermal shutdown hysteresis			10		
Operating free-air temperature, T_A		–40		85	

(1) The algebraic convention, in which the least positive (most negative) limit is designated as minimum is used in this data sheet.

8.4 Thermal Information

THERMAL METRIC ⁽¹⁾		SN65HVD230	SN65HVD231	SN65HVD232	UNIT
		D			
		8 PINS			
$R_{\theta JA}$	Junction-to-ambient thermal resistance	76.8	101.5	101.5	°C/W
$R_{\theta JC(top)}$	Junction-to-case (top) thermal resistance	33.4	43.3	43.3	°C/W
$R_{\theta JB}$	Junction-to-board thermal resistance	15.3	42.2	42.4	°C/W
ψ_{JT}	Junction-to-top characterization parameter	1.4	4.8	4.8	°C/W
ψ_{JB}	Junction-to-board characterization parameter	14.9	41.8	41.8	°C/W

(1) For more information about traditional and new thermal metrics, see the [Semiconductor and IC Package Thermal Metrics](#) application report.

8.5 Electrical Characteristics: Driver

over recommended operating conditions (unless otherwise noted)

PARAMETER		TEST CONDITIONS			MIN	TYP ⁽¹⁾	MAX	UNIT		
V _{OH}	Bus output voltage	Dominant	V _I = 0 V, See Figure 18 and Figure 20	CANH	2.45		V _{CC}	V		
				CANL	0.5		1.25			
V _{OL}	Bus output voltage	Recessive	V _I = 3 V, See Figure 18 and Figure 20	CANH		2.3				
				CANL		2.3				
V _{OD(D)}	Differential output voltage	Dominant	V _I = 0 V, See Figure 18		1.5	2	3	V		
			V _I = 0 V, See Figure 19		1.2	2	3			
V _{OD(R)}	Differential output voltage	Recessive	V _I = 3 V, See Figure 18		-120	0	12	mV		
			V _I = 3 V, No load		-0.5	-0.2	0.05	V		
I _{IH}	High-level input current		V _I = 2 V		-30			μA		
I _{IL}	Low-level input current		V _I = 0.8 V		-30			μA		
I _{OS}	Short-circuit output current		V _{CANH} = -2 V		-250			250	mA	
			V _{CANL} = 7 V		-250			250		
C _O	Output capacitance		See receiver							
I _{CC}	Supply current	Standby	SN65HVD230	V _(RS) = V _{CC}		370		600	μA	
		Sleep	SN65HVD231	V _(RS) = V _{CC} , D at V _{CC}		0.04		1		
		All devices	Dominant	V _I = 0 V, No load		Dominant	10		17	mA
			Recessive	V _I = V _{CC} , No load		Recessive	10		17	

(1) All typical values are at 25°C and with a 3.3-V supply.

8.6 Electrical Characteristics: Receiver

over recommended operating conditions (unless otherwise noted)

PARAMETER		TEST CONDITIONS			MIN	TYP ⁽¹⁾	MAX	UNIT	
V _{IT+}	Positive-going input threshold voltage	See Table 1			750		900	mV	
V _{IT-}	Negative-going input threshold voltage				500		650		mV
V _{hys}	Hysteresis voltage (V _{IT+} - V _{IT-})						100		
V _{OH}	High-level output voltage	-6 V ≤ V _{ID} ≤ 500 mV, I _O = -8 mA, See Figure 22			2.4			V	
V _{OL}	Low-level output voltage	900 mV ≤ V _{ID} ≤ 6 V, I _O = 8 mA, See Figure 22			0.4				
I _I	Bus input current	V _{IH} = 7 V		Other input at 0 V, D = 3 V	100		250	μA	
		V _{IH} = 7 V, V _{CC} = 0 V			100		350		
		V _{IH} = -2 V			-200		-30	μA	
		V _{IH} = -2 V, V _{CC} = 0 V			-100		-20		
C _I	CANH, CANL input capacitance	Pin-to-ground, V _I = 0.4 sin(4E6πt) + 0.5 V		V _(D) = 3 V,		32		pF	
C _{Diff}	Differential input capacitance	Pin-to-pin, V _I = 0.4 sin(4E6πt) + 0.5 V		V _(D) = 3 V,		16		pF	
R _{Diff}	Differential input resistance	Pin-to-pin, V _(D) = 3 V		40		70	100	kΩ	
R _I	CANH, CANL input resistance				20		35	50	kΩ
I _{CC}	Supply current	See driver							

(1) All typical values are at 25°C and with a 3.3-V supply.

8.7 Switching Characteristics: Driver

over recommended operating conditions (unless otherwise noted)

PARAMETER		TEST CONDITIONS	MIN	TYP	MAX	UNIT		
SN65HVD230 AND SN65HVD231								
t_{PLH}	Propagation delay time, low-to-high-level output	$V_{(RS)} = 0\text{ V}$		35	85	ns		
		R_S with 10 k Ω to ground		70	125			
		R_S with 100 k Ω to ground		500	870			
t_{PHL}	Propagation delay time, high-to-low-level output	$V_{(RS)} = 0\text{ V}$		70	120	ns		
		R_S with 10 k Ω to ground		130	180			
		R_S with 100 k Ω to ground		870	1200			
$t_{sk(p)}$	Pulse skew ($ t_{PHL} - t_{PLH} $)	$V_{(RS)} = 0\text{ V}$	$C_L = 50\text{ pF}$, See Figure 21	35		ns		
		R_S with 10 k Ω to ground		60				
		R_S with 100 k Ω to ground		370				
t_r	Differential output signal rise time	$V_{(RS)} = 0\text{ V}$		25	50	100	ns	
t_f	Differential output signal fall time			40	55	80	ns	
t_r	Differential output signal rise time		R_S with 10 k Ω to ground		80	120	160	ns
t_f	Differential output signal fall time				80	125	150	ns
t_r	Differential output signal rise time		R_S with 100 k Ω to ground		600	800	1200	ns
t_f	Differential output signal fall time				600	825	1000	ns
SN65HVD232								
t_{PLH}	Propagation delay time, low-to-high-level output	$C_L = 50\text{ pF}$, See Figure 21		35	85	ns		
t_{PHL}	Propagation delay time, high-to-low-level output			70	120			
$t_{sk(p)}$	Pulse skew ($ t_{PHL} - t_{PLH} $)			35				
t_r	Differential output signal rise time			25	50		100	
t_f	Differential output signal fall time			40	55		80	

8.8 Switching Characteristics: Receiver

over recommended operating conditions (unless otherwise noted)

PARAMETER		TEST CONDITIONS	MIN	TYP	MAX	UNIT
t_{PLH}	Propagation delay time, low-to-high-level output	See Figure 23		35	50	ns
t_{PHL}	Propagation delay time, high-to-low-level output			35	50	ns
$t_{sk(p)}$	Pulse skew ($ t_{PHL} - t_{PLH} $)				10	ns
t_r	Output signal rise time	See Figure 23		1.5		ns
t_f	Output signal fall time				1.5	ns

8.9 Switching Characteristics: Device

over recommended operating conditions (unless otherwise noted)

PARAMETER		TEST CONDITIONS	MIN	TYP	MAX	UNIT
$t_{(LOOP1)}$	Total loop delay, driver input to receiver output, recessive to dominant	$V_{(RS)} = 0\text{ V}$, See Figure 26		70	115	ns
		R_S with 10 k Ω to ground, See Figure 26		105	175	
		R_S with 100 k Ω to ground, See Figure 26		535	920	
$t_{(LOOP2)}$	Total loop delay, driver input to receiver output, dominant to recessive	$V_{(RS)} = 0\text{ V}$, See Figure 26		100	135	ns
		R_S with 10 k Ω to ground, See Figure 26		155	185	
		R_S with 100 k Ω to ground, See Figure 26		830	990	

8.10 Device Control-Pin Characteristics

over recommended operating conditions (unless otherwise noted)

PARAMETER		TEST CONDITIONS	MIN	TYP ⁽¹⁾	MAX	UNIT
t _(WAKE)	SN65HVD230 wake-up time from standby mode with R _S	See Figure 25		0.55	1.5	μs
	SN65HVD231 wake-up time from sleep mode with R _S			3	5	μs
V _{ref}	Reference output voltage	-5 μA < I _(Vref) < 5 μA	0.45 V _{CC}		0.55 V _{CC}	V
		-50 μA < I _(Vref) < 50 μA	0.4 V _{CC}		0.6 V _{CC}	
I _(RS)	Input current for high-speed	V _(RS) < 1 V	-450		0	μA

(1) All typical values are at 25°C and with a 3.3-V supply.

8.11 Typical Characteristics

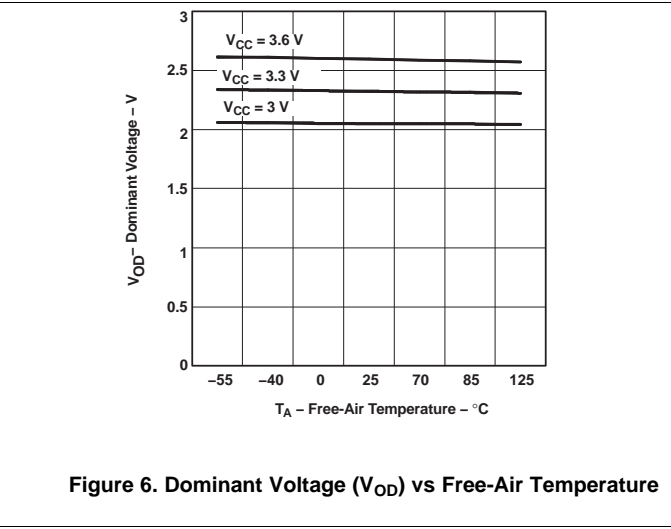
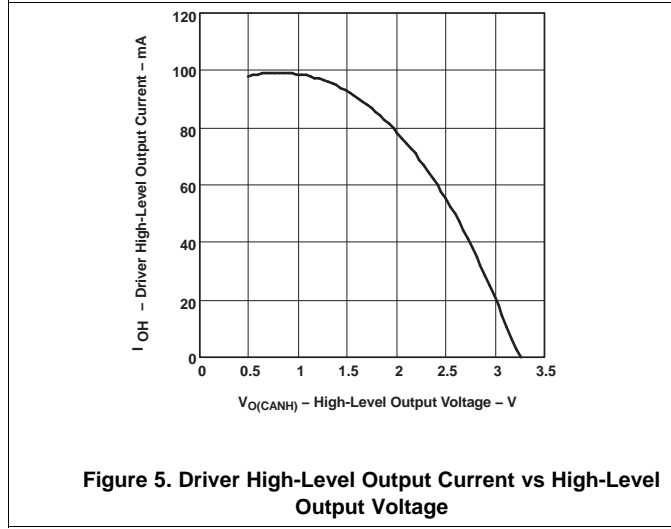
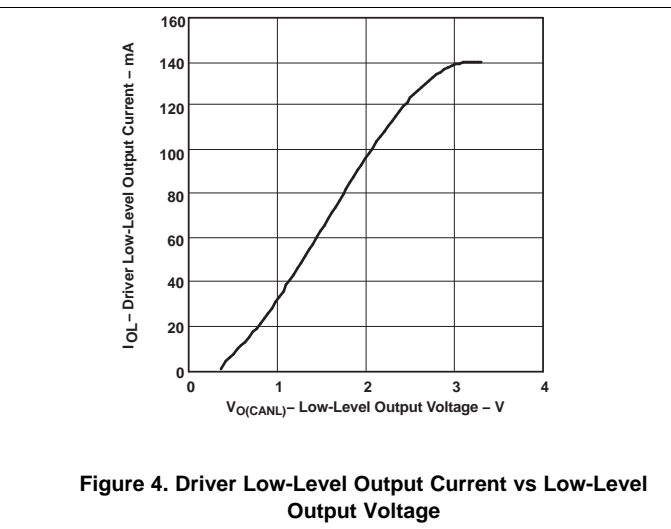
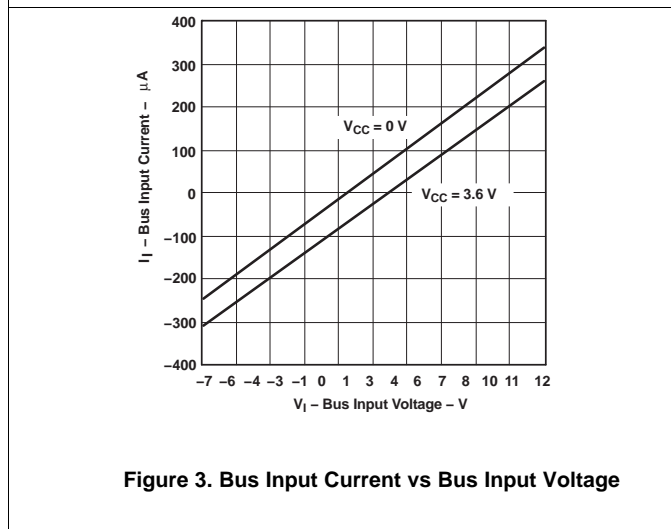
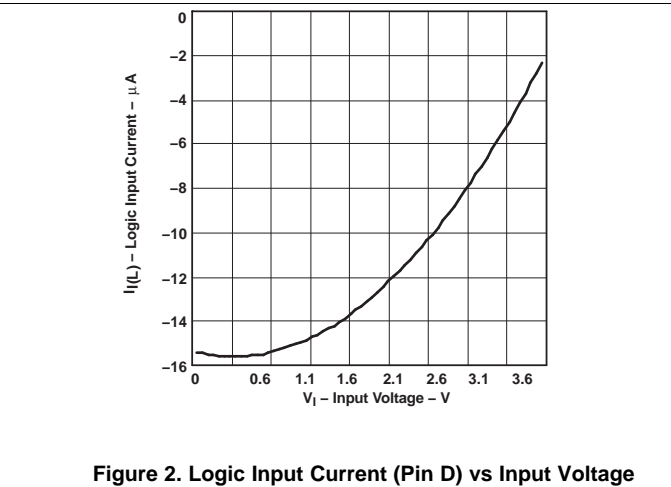
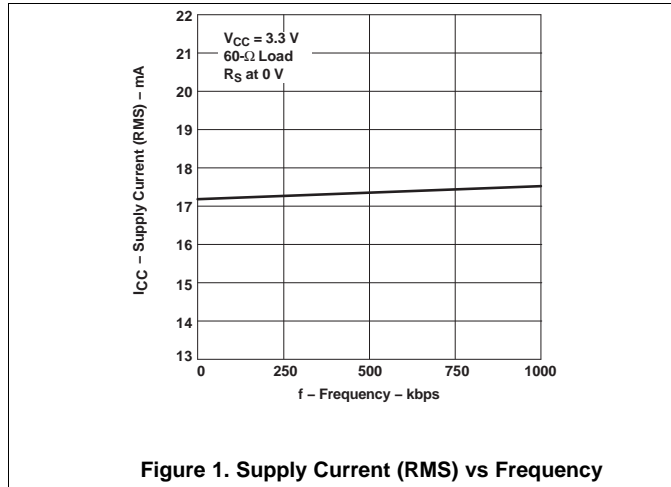

Typical Characteristics (continued)

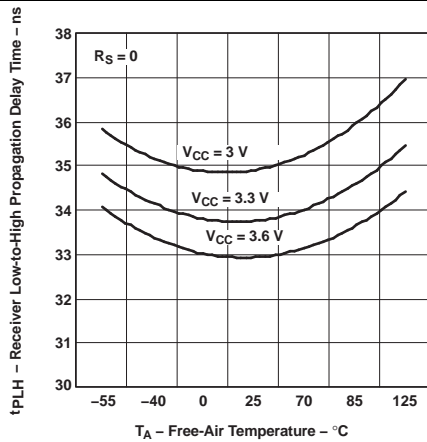

Figure 7. Receiver Low-to-High Propagation Delay Time vs Free-Air Temperature

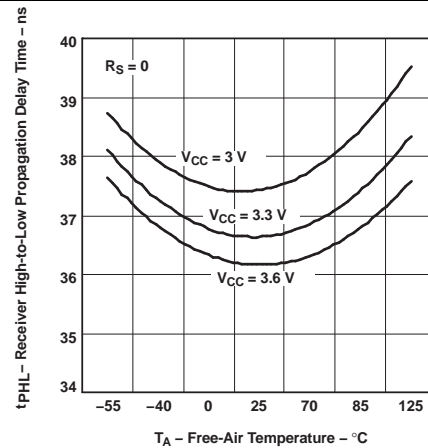

Figure 8. Receiver High-to-Low Propagation Delay Time vs Free-Air Temperature

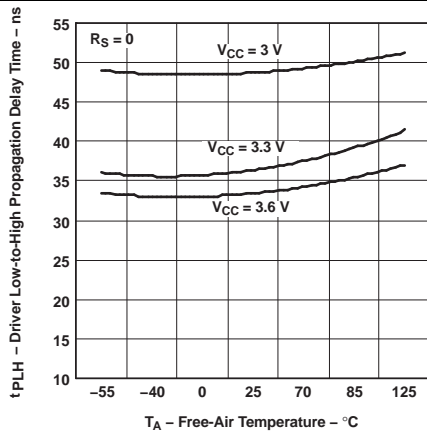

Figure 9. Driver Low-to-High Propagation Delay Time vs Free-Air Temperature

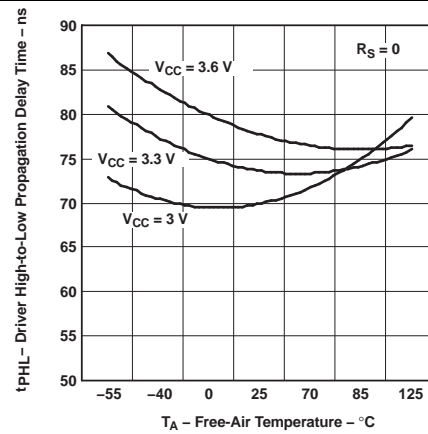

Figure 10. Driver High-to-Low Propagation Delay Time vs Free-Air Temperature

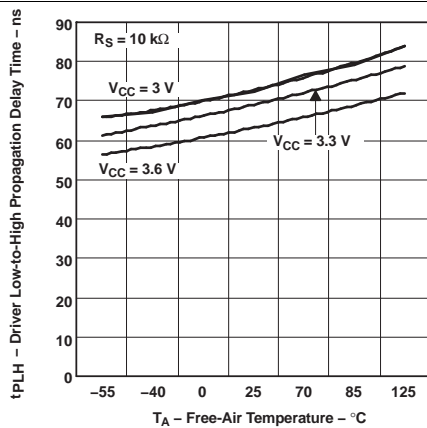

Figure 11. Driver Low-to-High Propagation Delay Time vs Free-Air Temperature

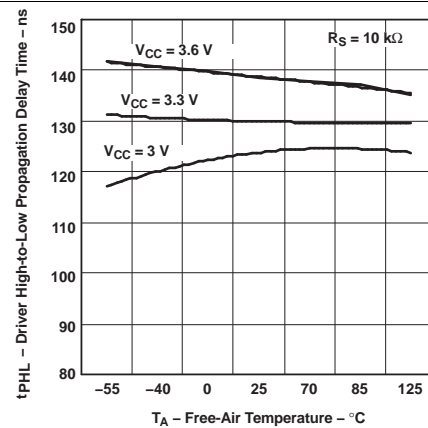

Figure 12. Driver High-to-Low Propagation Delay Time vs Free-Air Temperature

Typical Characteristics (continued)

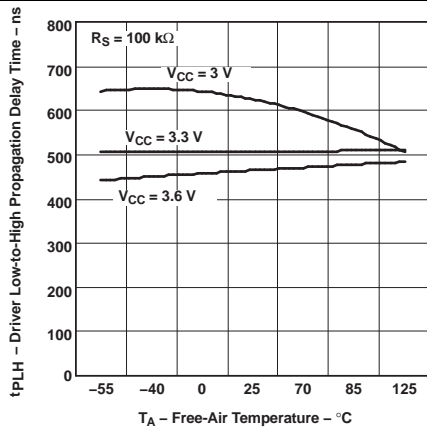

Figure 13. Driver Low-to-High Propagation Delay Time vs Free-Air Temperature

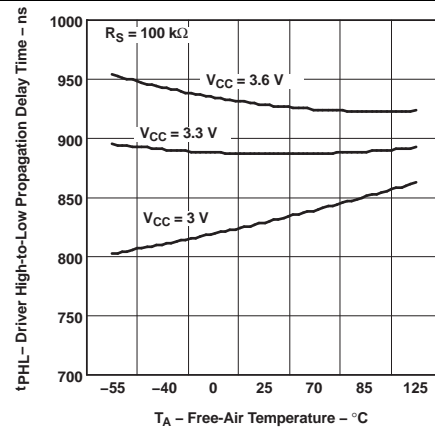

Figure 14. Driver High-to-Low Propagation Delay Time vs Free-Air Temperature

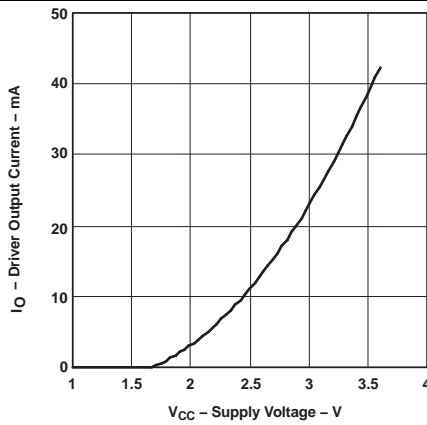

Figure 15. Driver Output Current vs Supply Voltage

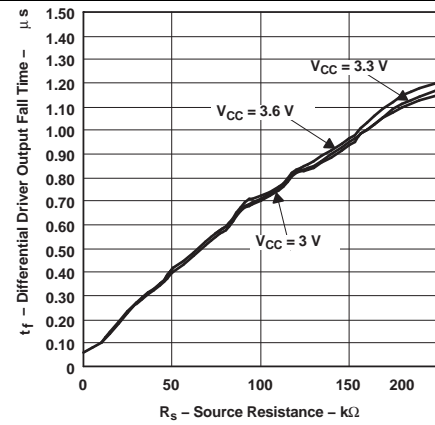

Figure 16. Differential Driver Output Fall Time vs Source Resistance (Rs)

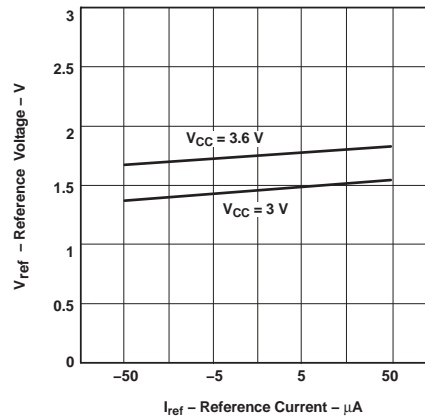

Figure 17. Reference Voltage vs Reference Current

9 Parameter Measurement Information

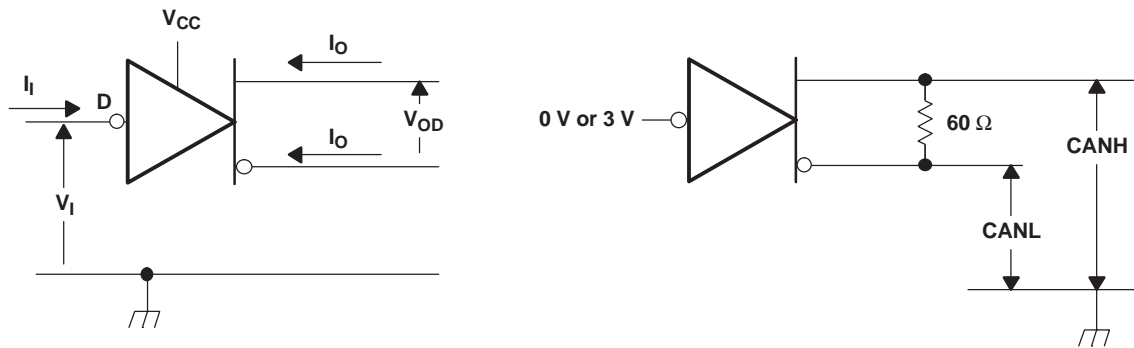

Figure 18. Driver Voltage and Current Definitions

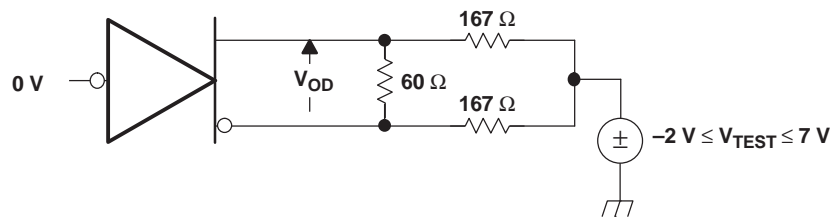

Figure 19. Driver V_{OD}

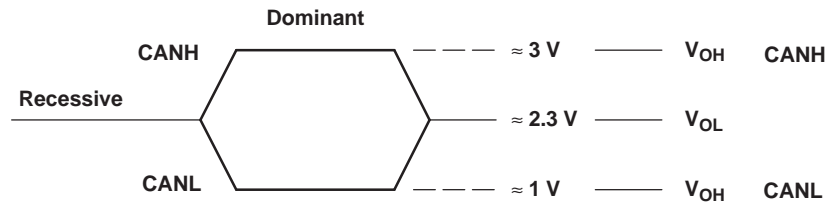
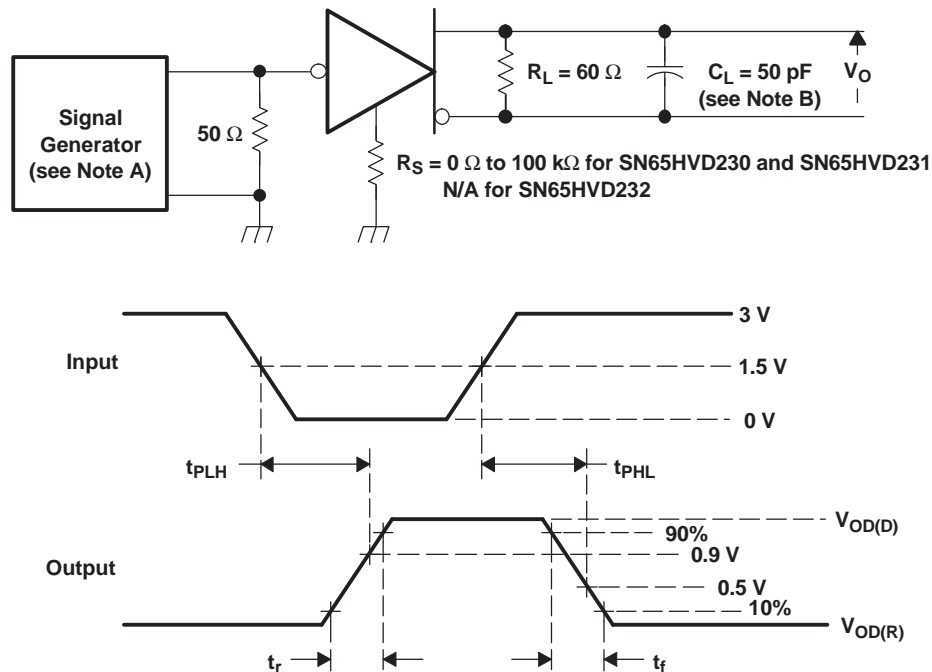
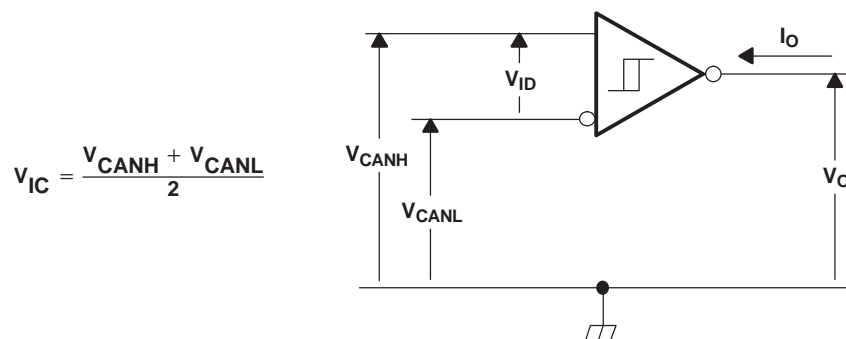

Figure 20. Driver Output Voltage Definitions

Parameter Measurement Information (continued)

- A. The input pulse is supplied by a generator having the following characteristics: PRR \leq 500 kHz, 50% duty cycle, $t_r \leq$ 6 ns, $t_f \leq$ 6 ns, $Z_o = 50 \Omega$.
- B. C_L includes probe and jig capacitance.

Figure 21. Driver Test Circuit and Voltage Waveforms

Figure 22. Receiver Voltage and Current Definitions

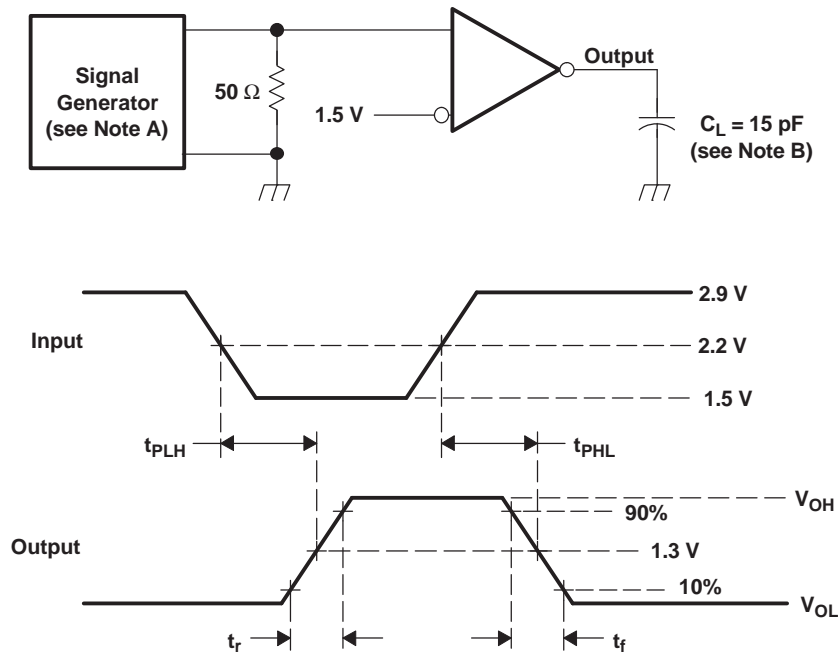
Parameter Measurement Information (continued)



- A. The input pulse is supplied by a generator having the following characteristics: PRR \leq 500 kHz, 50% duty cycle, $t_r \leq 6$ ns, $t_f \leq 6$ ns, $Z_o = 50 \Omega$.
- B. C_L includes probe and jig capacitance.

Figure 23. Receiver Test Circuit and Voltage Waveforms

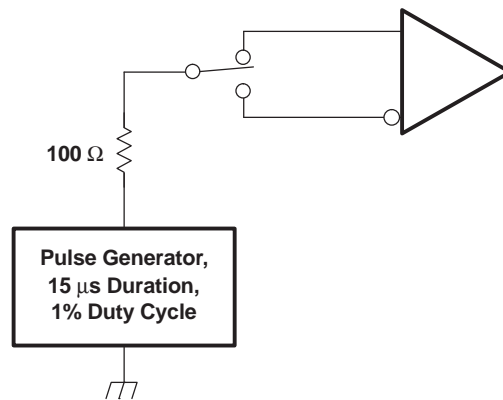

Figure 24. Overvoltage Protection

Parameter Measurement Information (continued)
Table 1. Receiver Characteristics Over Common Mode With $V_{(Rs)} = 1.2\text{ V}$

V_{IC}	V_{ID}	V_{CANH}	V_{CANL}	R OUTPUT	
-2 V	900 mV	-1.55 V	-2.45 V	L	V_{OL}
7 V	900 mV	8.45 V	6.55 V	L	
1 V	6 V	4 V	-2 V	L	
4 V	6 V	7 V	1 V	L	
-2 V	500 mV	-1.75 V	-2.25 V	H	V_{OH}
7 V	500 mV	7.25 V	6.75 V	H	
1 V	-6 V	-2 V	4 V	H	
4 V	-6 V	1 V	7 V	H	
X	X	Open	Open	H	

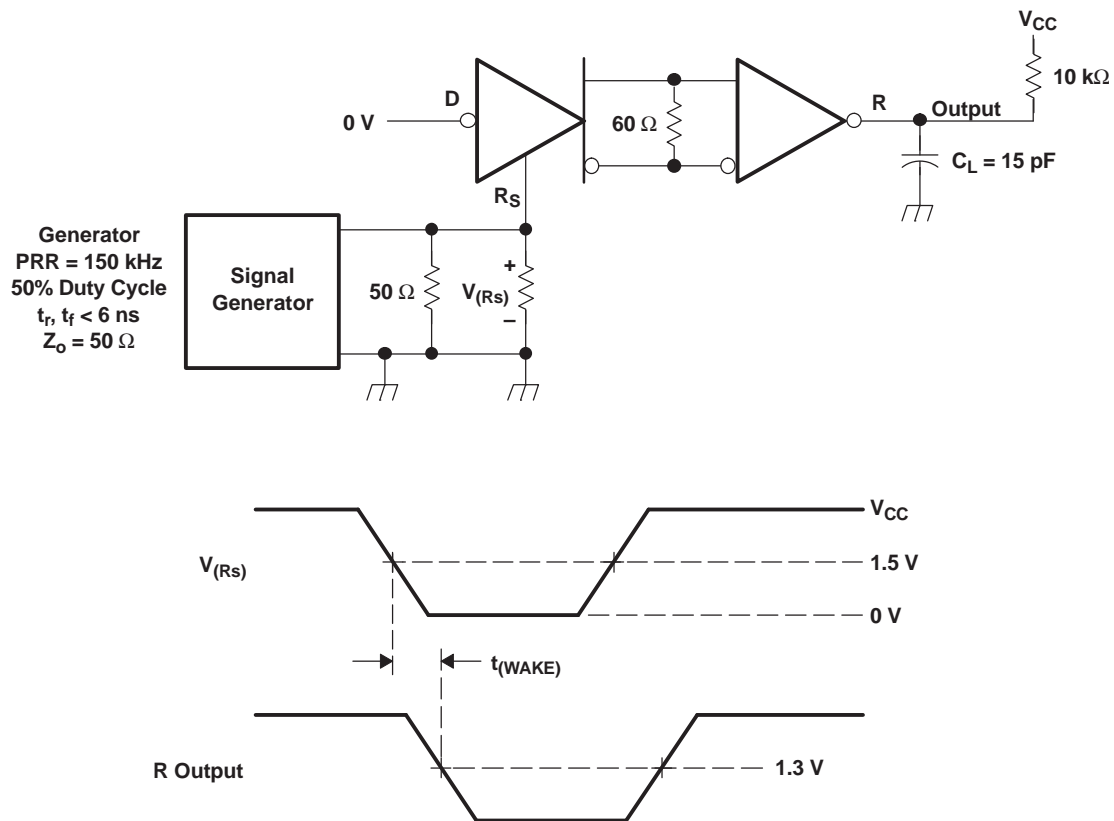
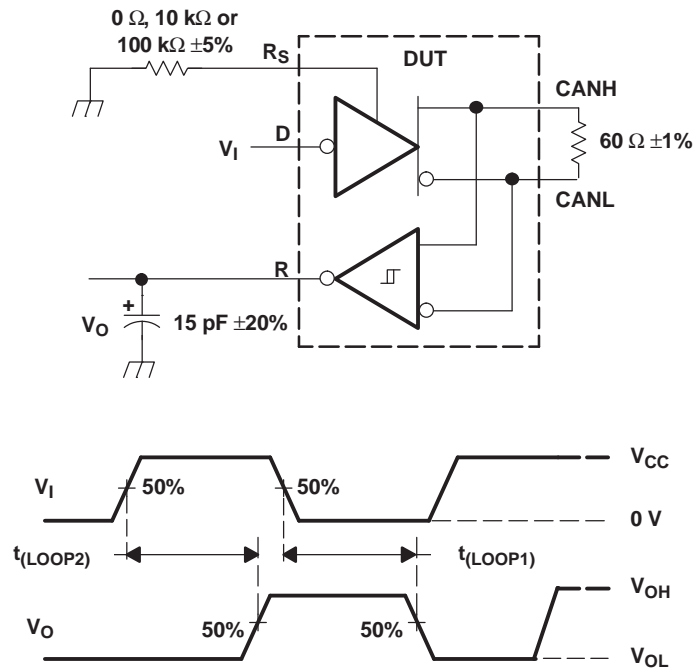

Figure 25. $t_{(WAKE)}$ Test Circuit and Voltage Waveforms



- A. All V_1 input pulses are supplied by a generator having the following characteristics: t_r or $t_f \leq 6$ ns, Pulse Repetition Rate (PRR) = 125 kHz, 50% duty cycle.

Figure 26. $t_{(LOOP)}$ Test Circuit and Voltage Waveforms

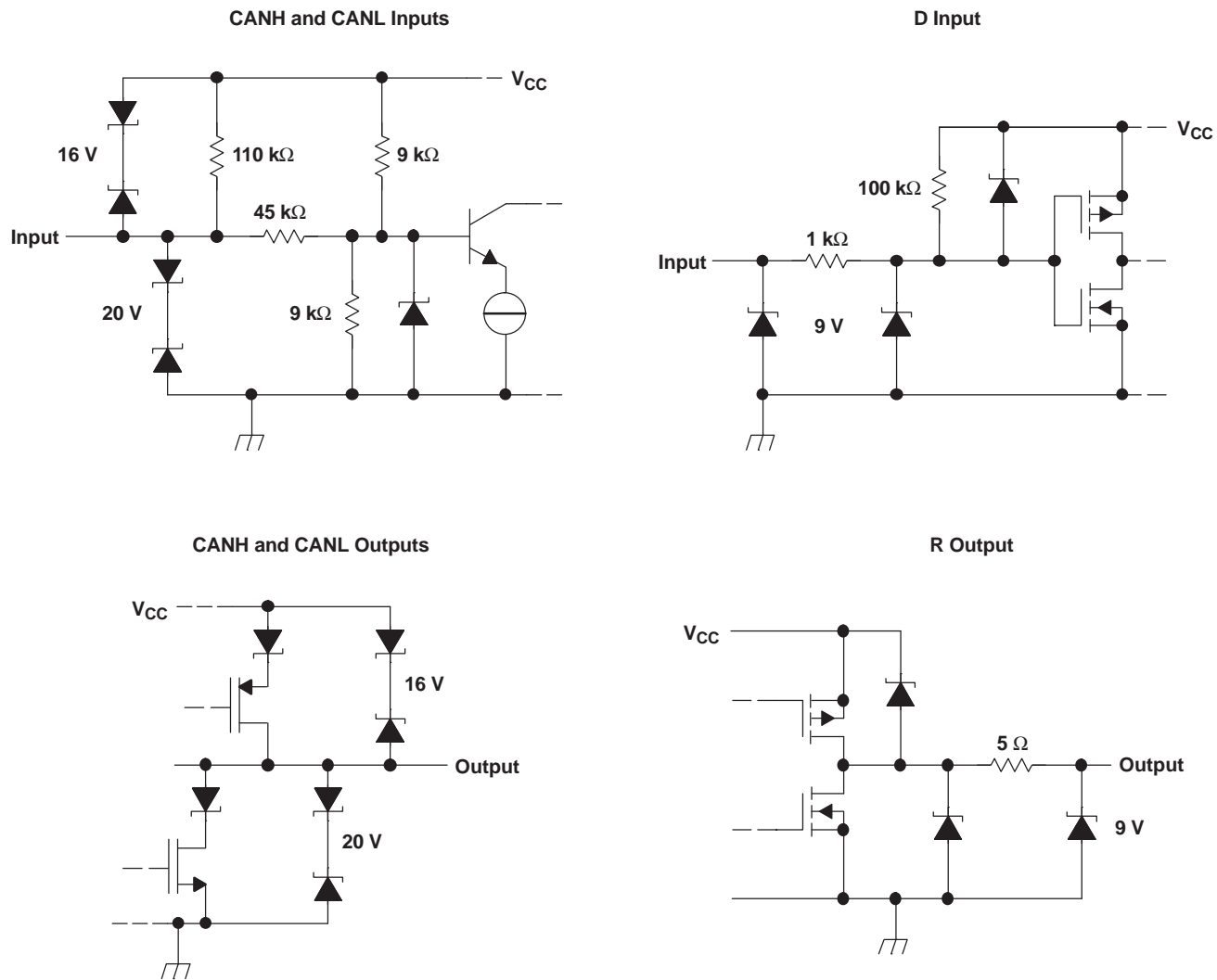

Figure 27. Equivalent Input and Output Schematic Diagrams

10 Detailed Description

10.1 Overview

ISO 11898 family of standards are the international standard for high speed serial communication using the controller area network (CAN) bus protocol and physical layers (transceivers). It supports multimaster operation, real time control, programmable data rates up to 1 Mbps, and powerful redundant error checking procedures that provide reliable data transmission. It is suited for networking *intelligent* devices as well as sensors and actuators within the rugged electrical environment of a machine chassis or factory floor. The SN65HVD23x family of 3.3 V CAN transceivers implement the lowest layers of the ISO/OSI reference model, the ISO11898-2 standard. This is the interface with the physical signaling output of the CAN controller of the Texas Instruments μ Ps, MCUs and DSPs, such as TMS320Lx240x 3.3 V DSPs, as illustrated in Figure 28.

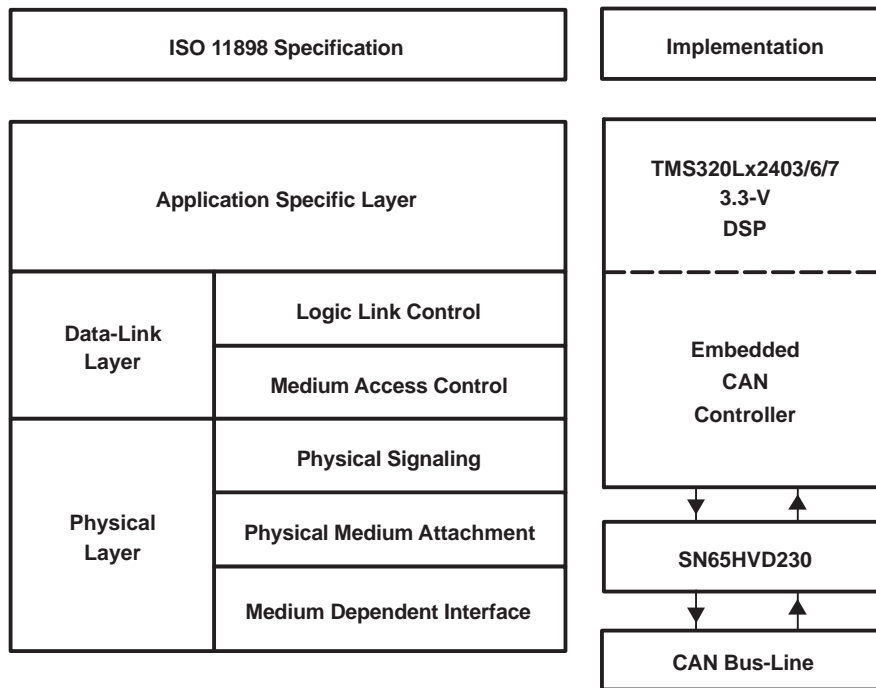

Figure 28. Layered ISO 11898 Standard Architecture

10.2 Functional Block Diagram

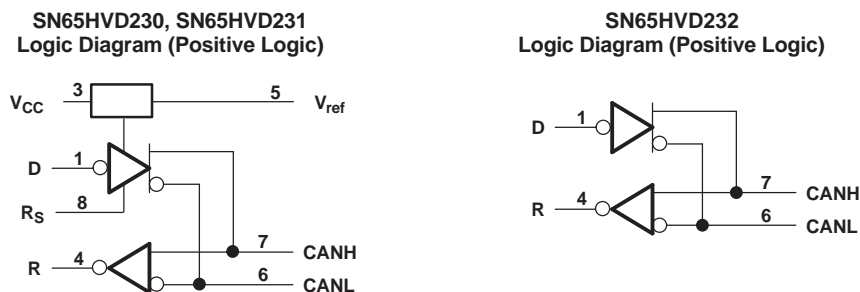

Figure 29. Logic Diagram (Positive Logic)

10.3 Feature Description

The SN65HVD230/231/232 are pin-compatible (but not functionally identical) with one another and, depending upon the application, may be used with identical circuit boards.

These transceivers feature single 3.3 V supply operation and standard compatibility with signaling rates up to 1 Mbps, ± 16 kV HBM ESD protection on the bus pins, thermal shutdown protection, bus fault protection, and open-circuit receiver failsafe. The fail-safe design of the receiver assures a logic high at the receiver output if the bus wires become open circuited.

The bus pins are also maintained in a high-impedance state during low V_{CC} conditions to ensure glitch-free power-up and power-down bus protection for hot-plugging applications. This high-impedance condition also means that an unpowered node does not disturb the bus. Transceivers without this feature usually have a very low output impedance. This results in a high current demand when the transceiver is unpowered, a condition that could affect the entire bus.

10.3.1 V_{ref} Voltage Reference

The V_{ref} pin (pin 5) on the SN65HVD230 and SN65HVD231 is available as a $V_{CC}/2$ voltage reference. This pin can be connected to the common mode point of a split termination to help further stabilize the common mode voltage of the bus. If the V_{ref} pin is not used it may be left floating.

10.3.2 Thermal Shutdown

If a high ambient temperature or excessive output currents result in thermal shutdown, the driver will be disabled and the bus pins become high impedance. During thermal shutdown the D pin to bus transmission path is blocked and the CAN bus pins are high impedance and biased to a recessive level. Once the thermal shutdown condition is cleared and the junction temperature drops below the thermal shutdown temperature the driver will be reactivated and resume normal operation. During a thermal shutdown the receiver to R pin path remains operational.

10.4 Device Functional Modes

The R_S pin (Pin 8) of the SN65HVD230 and SN65HVD231 provides three different modes of operation: high-speed mode, slope-control mode, and low-power mode.

10.4.1 High-Speed Mode

The high-speed mode can be selected by applying a logic low to the R_S pin (pin 8). The high-speed mode of operation is commonly employed in industrial applications. High-speed allows the output to switch as fast as possible with no internal limitation on the output rise and fall slopes. If the high speed transitions are a concern for emissions performance slope control mode can be used.

If both high speed mode and the low-power standby mode is to be used in the application, direct connection to a μP , MCU or DSP general purpose output pin can be used to switch between a logic-low level (< 1.2 V) for high speed operation, and the logic-high level ($> 0.75 V_{CC}$) for standby. [Figure 30](#) shows a typical DSP connection, and [Figure 31](#) shows the HVD230 driver output signal in high-speed mode on the CAN bus.

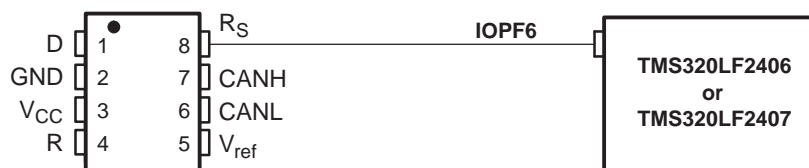

Figure 30. R_S (Pin 8) Connection to a TMS320LF2406/07 for High Speed/Standby Operation

Device Functional Modes (continued)

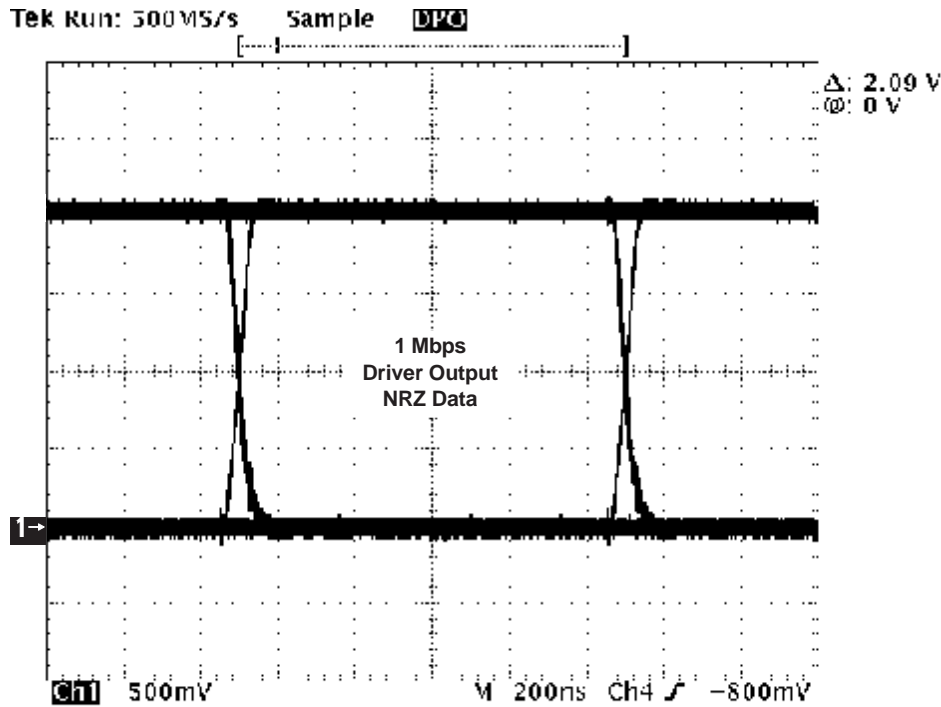

Figure 31. Typical High Speed SN65HVD230 Output Waveform into a 60-Ω Load

10.4.2 Slope Control Mode

Electromagnetic compatibility is essential in many applications while still making use of unshielded twisted pair bus cable to reduce system cost. Slope control mode was added to the SN65HVD230 and SN65HVD231 devices to reduce the electromagnetic interference produced by the rise and fall times of the driver and resulting harmonics. These rise and fall slopes of the driver outputs can be adjusted by connecting a resistor from R_S (pin 8) to ground or to a logic low voltage, as shown in Figure 32. The slope of the driver output signal is proportional to the pin's output current. This slope control is implemented with an external resistor value of 10 kΩ to achieve a ~15 V/μs slew rate, and up to 100 kΩ to achieve a ~2.0 V/μs slew rate as displayed in Figure 33.

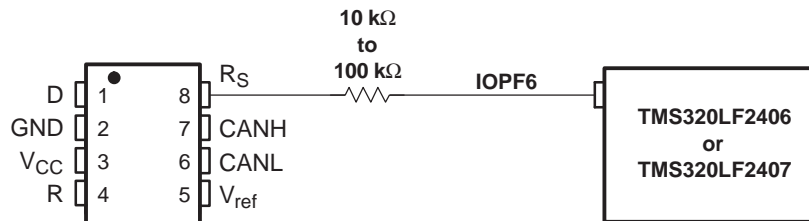

Figure 32. Slope Control/Standby Connection to a DSP

Device Functional Modes (continued)

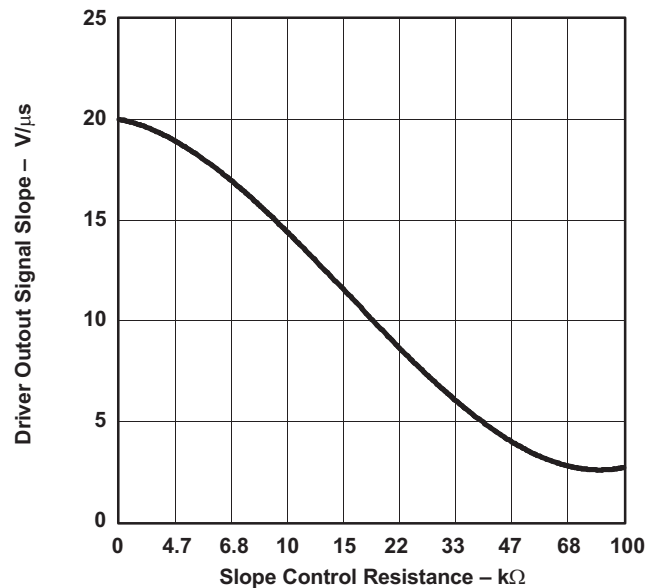

Figure 33. HVD230 Driver Output Signal Slope vs Slope Control Resistance Value

10.4.3 Standby Mode (Listen Only Mode) of the HVD230

If a logic high ($> 0.75 V_{CC}$) is applied to R_S (pin 8) in [Figure 30](#) and [Figure 32](#), the circuit of the SN65HVD230 enters a low-current, *listen only* standby mode, during which the driver is switched off and the receiver remains active. In this *listen only* state, the transceiver is completely passive to the bus. It makes no difference if a slope control resistor is in place as shown in [Figure 32](#). The μP can reverse this low-power standby mode when the rising edge of a dominant state (bus differential voltage > 900 mV typical) occurs on the bus. The μP , sensing bus activity, reactivates the driver circuit by placing a logic low (< 1.2 V) on R_S (pin 8).

10.4.4 The Babbling Idiot Protection of the HVD230

Occasionally, a runaway CAN controller unintentionally sends messages that completely tie up the bus (what is referred to in CAN jargon as a babbling idiot). When this occurs, the μP , MCU or DSP can engage the *listen-only* standby mode of the transceiver to disable the driver and release the bus, even when access to the CAN controller has been lost. When the driver circuit is deactivated, its outputs default to a high-impedance state (recessive).

10.4.5 Sleep Mode of the HVD231

The unique difference between the SN65HVD230 and the SN65HVD231 is that both driver and receiver are switched off in the SN65HVD231 when a logic high is applied to R_S (pin 8). The device remains in a very low power-sleep mode until the circuit is reactivated with a logic low applied to R_S (pin 8). While in this sleep mode, the bus-pins are in a high-impedance state, while the D and R pins default to a logic high.

10.4.6 Summary of Device Operating Modes

[Table 2](#) shows a summary of the operating modes for the SN65HVD230 and SN65HVD231. Please note that the SN65HVD232 is a basic CAN transceiver has only the normal high speed mode of operation; pins 5 and 8 are no connection (NC).

Device Functional Modes (continued)
Table 2. SN65HVD230 and SN65HVD231 Operating Modes

R _S Pin	MODE		DRIVER	RECEIVER	RXD Pin
LOW, V _(RS) < 1.2 V, strong pull down to GND	High Speed Mode		Enabled (ON) High Speed	Enabled (ON)	Mirrors Bus State ⁽¹⁾
LOW, V _(RS) < 1.2 V, 10 kΩ to 100 kΩ pull down to GND	Slope Control Mode		Enabled (ON) with Slope Control	Enabled (ON)	Mirrors Bus State
HIGH, V _(RS) > 0.75 V _{CC}	Low Current Mode	SN65HVD230: Standby Mode	Disabled (OFF)	Enabled (ON)	Mirrors Bus State
		SN65HVD231: Sleep Mode		Disabled (OFF)	High

(1) Mirrors bus state: low if CAN bus is dominant, high if CAN bus is recessive.

Table 3. SN65HVD230 and SN65HVD231 Driver Functions

DRIVER (SN65HVD230, SN65HVD231) ⁽¹⁾				
INPUT D	R _S	OUTPUTS		BUS STATE
		CANH	CANL	
L	V _(RS) < 1.2 V (including 10 kΩ to 100 kΩ pull down to GND)	H	L	Dominant
H		Z	Z	Recessive
Open	X	Z	Z	Recessive
X	V _(RS) > 0.75 V _{CC}	Z	Z	Recessive

(1) H = high level; L = low level; X = irrelevant; ? = indeterminate; Z = high impedance

Table 4. SN65HVD230 Receiver Functions

RECEIVER (SN65HVD230) ⁽¹⁾		
DIFFERENTIAL INPUTS	R _S	OUTPUT R
V _{ID} ≥ 0.9 V	X	L
0.5 V < V _{ID} < 0.9 V	X	?
V _{ID} ≤ 0.5 V	X	H
Open	X	H

(1) H = high level; L = low level; X = irrelevant; ? = indeterminate

Table 5. SN65HVD231 Receiver Functions

RECEIVER (SN65HVD231) ⁽¹⁾		
DIFFERENTIAL INPUTS	R _S	OUTPUT R
V _{ID} ≥ 0.9 V	V _(RS) < 1.2 V (including 10 kΩ to 100 kΩ pull down to GND)	L
0.5 V < V _{ID} < 0.9 V		?
V _{ID} ≤ 0.5 V		H
X	V _(RS) > 0.75 V _{CC}	H
X	1.2 V < V _(RS) < 0.75 V _{CC}	?
Open	X	H

(1) H = high level; L = low level; X = irrelevant; ? = indeterminate

Table 6. SN65HVD232 Receiver Functions

RECEIVER (SN65HVD232) ⁽¹⁾	
DIFFERENTIAL INPUTS	OUTPUT R
$V_{ID} \geq 0.9 \text{ V}$	L
$0.5 \text{ V} < V_{ID} < 0.9 \text{ V}$?
$V_{ID} \leq 0.5 \text{ V}$	H
Open	H

(1) H = high level; L = low level; X = irrelevant; ? = indeterminate

Table 7. SN65HVD232 Driver Functions

DRIVER (SN65HVD232) ⁽¹⁾			
INPUT D	OUTPUTS		BUS STATE
	CANH	CANL	
L	H	L	Dominant
H	Z	Z	Recessive
Open	Z	Z	Recessive

(1) H = high level; L = low level; Z = high impedance

11 Application and Implementation

NOTE

Information in the following applications sections is not part of the TI component specification, and TI does not warrant its accuracy or completeness. TI's customers are responsible for determining suitability of components for their purposes. Customers should validate and test their design implementation to confirm system functionality.

11.1 Application Information

This application section provides information concerning the implementation of the physical medium attachment layer in a CAN network according to the ISO 11898 standard. It presents a typical application circuit and test results, as well as discussions on slope control, total loop delay, and interoperability in 5-V CAN systems.

11.1.1 CAN Bus States

The CAN bus has two states during powered operation of the device; *dominant* and *recessive*. A dominant bus state is when the bus is driven differentially, corresponding to a logic low on the D and R pin. A recessive bus state is when the bus is biased to $V_{CC} / 2$ via the high-resistance internal resistors R_1 and R_{Diff} of the receiver, corresponding to a logic high on the D and R pins. See Figure 34 and Figure 35.

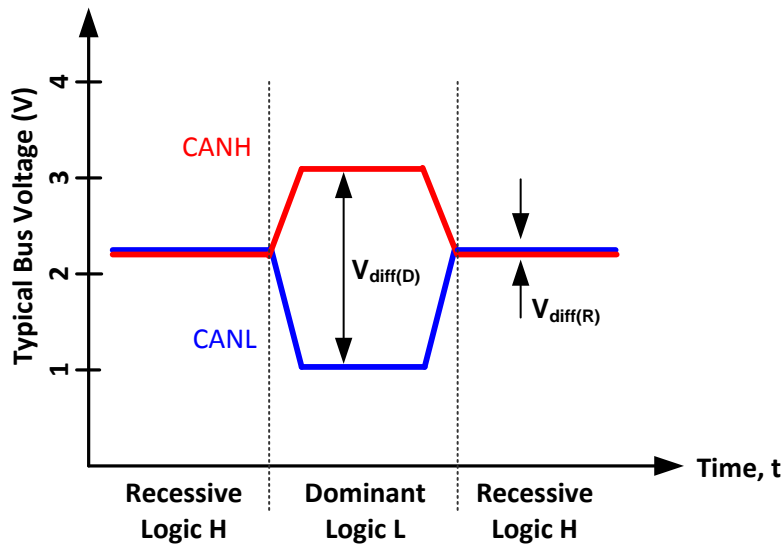

Figure 34. CAN Bus States (Physical Bit Representation)

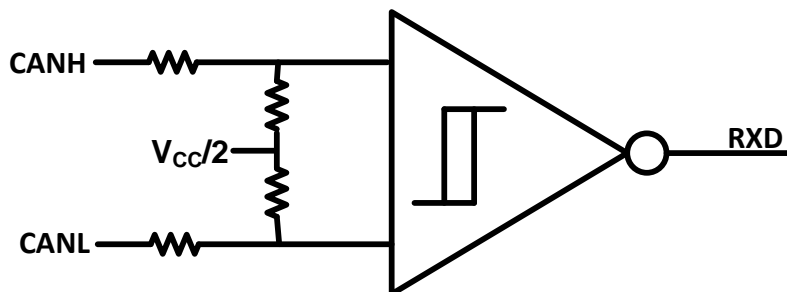

Figure 35. Simplified Recessive Common Mode Bias and Receiver

11.2 Typical Application

Figure 36 illustrates a typical application of the SN65HVD23x family. The output of the host μ P's CAN controller (TXD) is connected to the transceivers driver input, pin D, and the transceivers receiver output, pin R, is connected to the input of the CAN controller (RXD). The transceiver is attached to the differential bus lines at pins CANH and CANL. Typically, the bus is a twisted pair of wires with a characteristic impedance of $120\ \Omega$, in the standard half-duplex multipoint topology of Figure 37. Each end of the bus is terminated with $120\ \Omega$ resistors in compliance with the standard to minimize signal reflections on the bus.

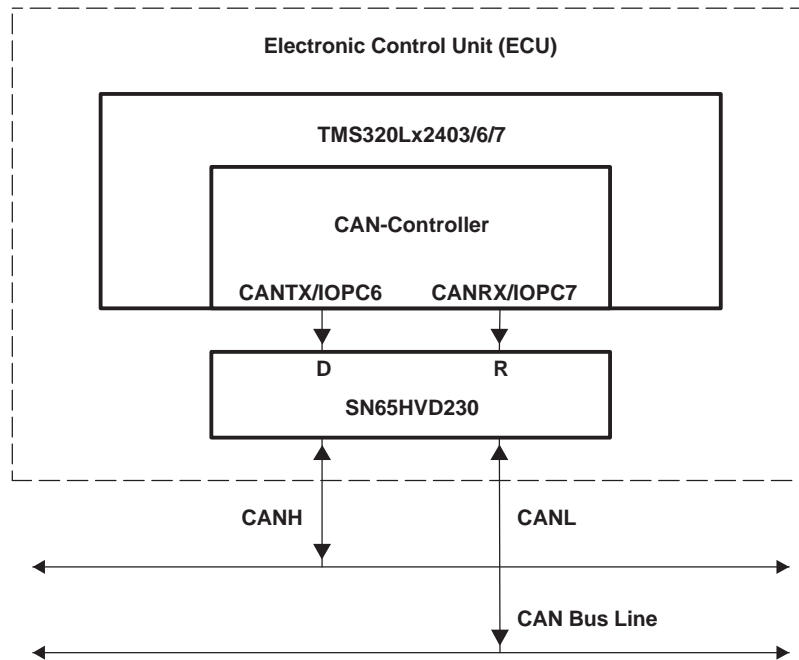

Figure 36. Details of a Typical CAN Node

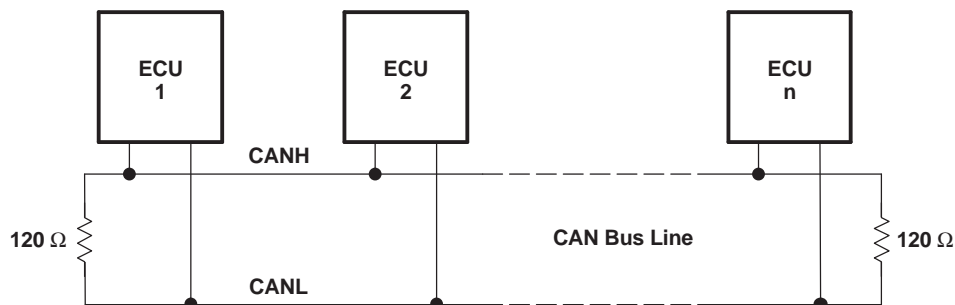

Figure 37. Typical CAN Network

11.2.1 Design Requirements

11.2.1.1 CAN Termination

The ISO11898 standard specifies the interconnect to be a single twisted pair cable (shielded or unshielded) with $120\ \Omega$ characteristic impedance (Z_0). Resistors equal to the characteristic impedance of the line should be used to terminate both ends of the cable to prevent signal reflections. Unterminated drop lines (stubs) connecting nodes to the bus should be kept as short as possible to minimize signal reflections. The termination may be on the cable or in a node, but if nodes may be removed from the bus the termination must be carefully placed so that it is not removed from the bus.

Typical Application (continued)

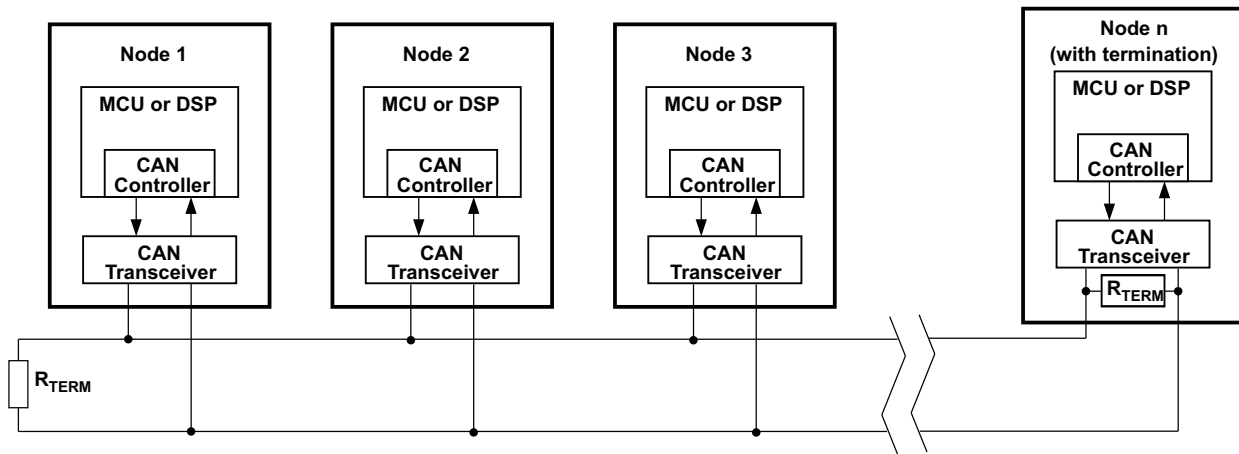

Figure 38. Typical CAN Bus

Termination is typically a 120 Ω resistor at each end of the bus. If filtering and stabilization of the common mode voltage of the bus is desired, then split termination may be used (see Figure 39). Split termination utilizes two 60 Ω resistors with a capacitor in the middle of these resistors to ground. Split termination improves the electromagnetic emissions behavior of the network by eliminating fluctuations in the bus common mode voltages at the start and end of message transmissions.

Care should be taken in the power ratings of the termination resistors used. Typically the worst case condition would be if the system power supply was shorted across the termination resistance to ground. In most cases the current flow through the resistor in this condition would be much higher than the transceiver's current limit.

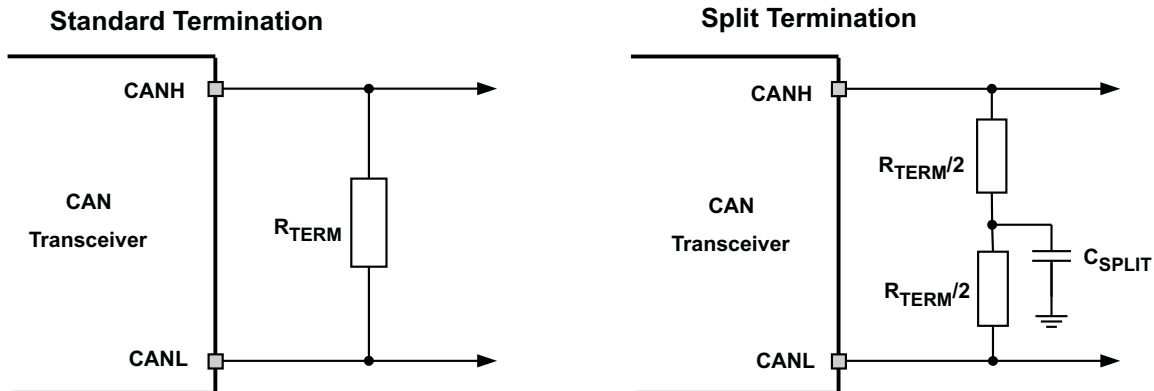

Figure 39. CAN Bus Termination Concepts

11.2.1.2 Loop Propagation Delay

Transceiver loop delay is a measure of the overall device propagation delay, consisting of the delay from the driver input (D pin) to the differential outputs (CANH and CANL pins), plus the delay from the receiver inputs (CANH and CANL) to its output (R pin).

Typical Application (continued)

A typical loop delay for the SN65HVD230 transceiver is displayed in Figure 40. This loop delay will increase as the slope of the driver output is slowed during slope control mode. This increased loop delay means that there is a tradeoff between the total bus length able to be used and the driver's output slope used via the slope control pin of the device. For example, the loop delay for a 10-k Ω resistor from the R_S pin to ground is ~100 ns, and the loop delay for a 100-k Ω resistor is ~500 ns. Therefore, if we use the following rule-of-thumb that the propagation delay of typical twisted pair bus cable is 5 ns/m, we can calculate an approximate cable length trade-off between normal high-speed mode and slope control mode with a 100-k Ω resistor. Using typical values, the loop delay for a recessive to dominant bit with R_S tied directly to ground is 70ns, and with a 100-k Ω resistor is 535 ns. At 5ns/m of propagation delay, which you have to count in both directions the difference is 46.5 meters $(535-70)/(2*5)$.

Another option to improving the electromagnetic emissions of the device besides slowing down the edge rates of the driver in slope control mode is using quality shielded bus cabling.

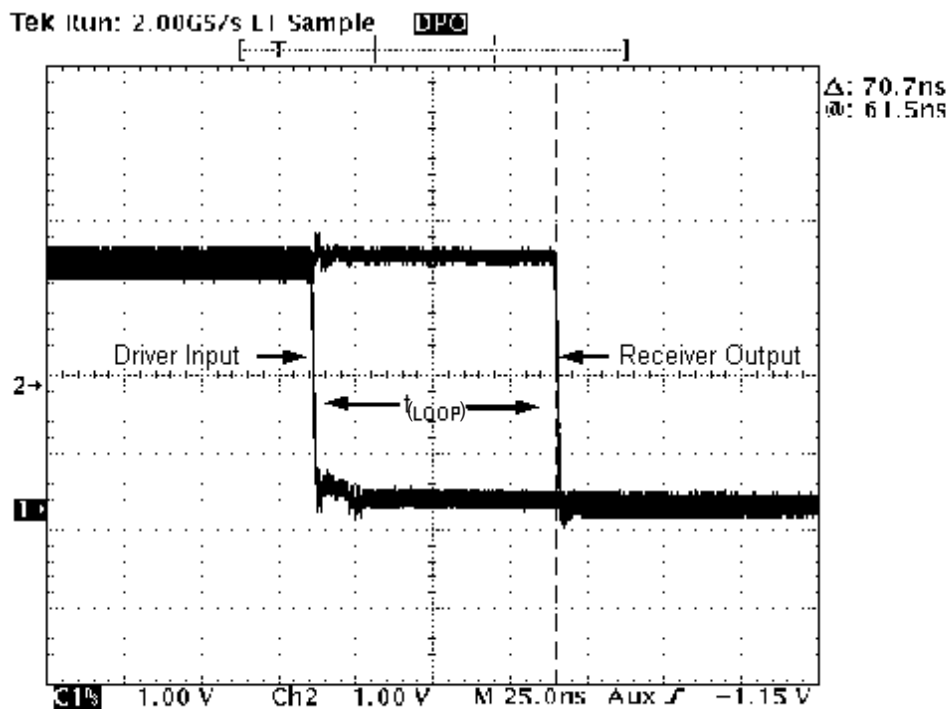

Figure 40. 70.7-ns Loop Delay Through the HVD230 With R_S = 0

11.2.1.3 Bus Loading, Length and Number of Nodes

The ISO11898 Standard specifies up to 1 Mbps data rate, maximum bus length of 40 meters, maximum drop line (stub) length of 0.3 meters and a maximum of 30 nodes. However, with careful network design, the system may have longer cables, longer stub lengths, and many more nodes. Many CAN organizations and standards have scaled the use of CAN for applications outside the original ISO11898 standard. They have made system level trade-offs for data rate, cable length, and parasitic loading of the bus. Examples of some of these specifications are ARINC825, CANopen, CAN Kingdom, DeviceNet and NMEA200.

A high number of nodes requires a transceiver with high input impedance and wide common mode range such as the SN65HVD23x CAN family. ISO11898-2 specifies the driver differential output with a 60 Ω load (two 120 Ω termination resistors in parallel) and the differential output must be greater than 1.5 V. The SN65HVD23x devices are specified to meet the 1.5 V requirement with a 60 Ω load, and additionally specified with a differential output voltage minimum of 1.2 V across a common mode range of -2 V to 7 V via a 167 Ω coupling network. This network represents the bus loading of 120 SN65HVD23x transceivers based on their minimum differential input resistance of 40 k Ω . Therefore, the SN65HVD23x supports up to 120 transceivers on a single bus segment with margin to the 1.2 V minimum differential input voltage requirement at each node. For CAN network design,

Typical Application (continued)

margin must be given for signal loss across the system and cabling, parasitic loadings, network imbalances, ground offsets and signal integrity thus a practical maximum number of nodes may be lower. Bus length may also be extended beyond the original ISO11898 standard of 40 meters by careful system design and data rate tradeoffs. For example, CANopen network design guidelines allow the network to be up to 1 km with changes in the termination resistance, cabling, less than 64 nodes and significantly lowered data rate.

This flexibility in CAN network design is one of the key strengths of the various extensions and additional standards that have been built on the original ISO11898 CAN standard. In using this flexibility comes the responsibility of good network design.

11.2.2 Detailed Design Procedure

The following system level considerations should be looked at when designing your application. There are trade-offs between the total number of nodes, the length of the bus, and the slope of the driver output that need to be evaluated when building up a system

11.2.2.1 Transient Protection

Typical applications that use CAN will sometime require some form of ESD, burst, or surge protection performance at the system level. If these requirements are higher than those of the device some form of external protection may be needed to shield the transceiver against these high power transients that can cause damage. Transient voltage suppressor (TVS) are very commonly used and can help clamp the amount of energy that reaches the transceiver.

11.2.2.2 Transient Voltage Suppressors

Transient voltage suppressors are the preferred protection components for CAN bus applications due to their low capacitance, fast response times and high peak power dissipation limits. The low bus capacitance allows these devices to be used at many, if not all, nodes on the network without having to reduce the data rate. The quick response times in the order of a few picoseconds enable these devices to clamp the energy of very fast transients like ESD and EFT. Lastly, the high peak power ratings enable these devices to handle high energy surge pulses without being damaged.

11.2.3 Application Curve

Typical driver output waveforms from a pulse input signal with different slope control resistances are displayed in [Figure 41](#). The top waveform show the typical differential signal when transitioning from a recessive level to a dominant level on the CAN bus with R_S tied to GND through a zero ohm resistor. The second waveform shows the same signal for the condition with a 10k ohm resistor tied from R_S to ground. The bottom waveform shows the typical differential signal for the case where a 100k ohm resistor is tied from the R_S pin to ground.

Typical Application (continued)

Figure 41. Typical SN65HVD230 250-kbps Output Pulse Waveforms With Slope Control

11.3 System Example

11.3.1 ISO 11898 Compliance of SN65HVD23x Family of 3.3 V CAN Transceivers

11.3.1.1 Introduction

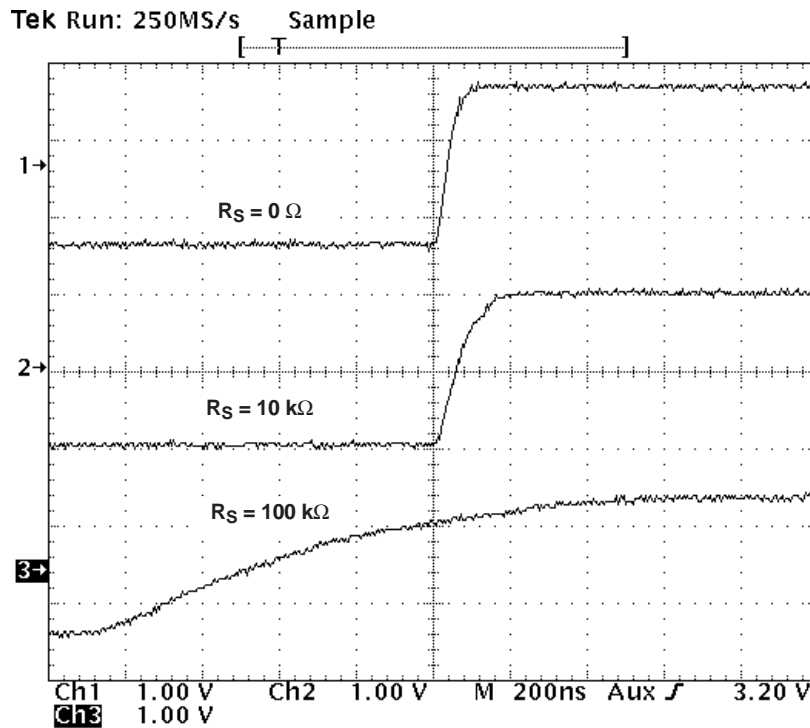
Many users value the low power consumption of operating their CAN transceivers from a 3.3 V supply. However, some are concerned about the interoperability with 5 V supplied transceivers on the same bus. This report analyzes this situation to address those concerns.

11.3.1.2 Differential Signal

CAN is a differential bus where complementary signals are sent over two wires and the voltage difference between the two wires defines the logical state of the bus. The differential CAN receiver monitors this voltage difference and outputs the bus state with a single-ended output signal.

System Example (continued)

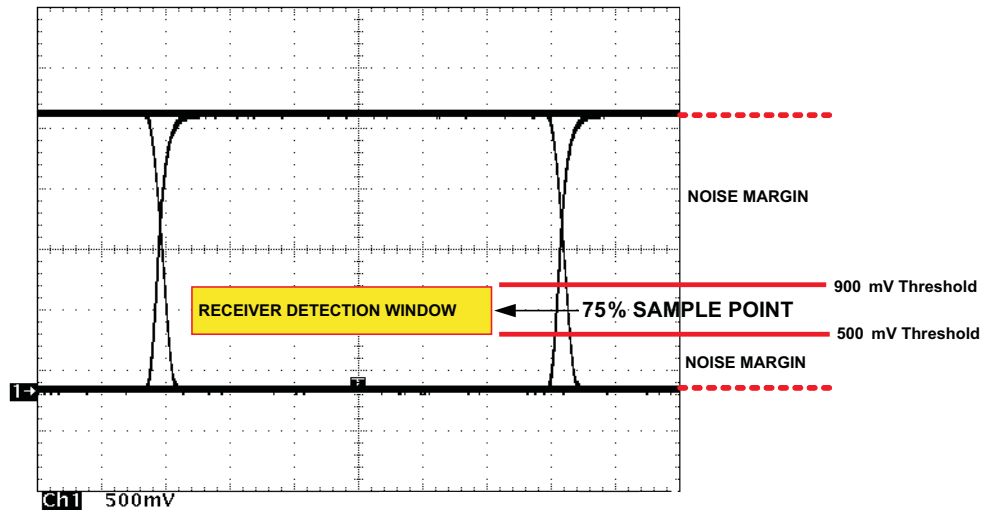

Figure 42. Typical SN65HVD230 Differential Output Voltage Waveform

The CAN driver creates the differential voltage between CANH and CANL in the dominant state. The dominant differential output of the SN65HVD23x is greater than 1.5 V and less than 3 V across a 60 ohm load as defined by the ISO 11898 standard. These are the same limiting values for 5 V supplied CAN transceivers. Typically, the bus termination resistors drive the bus back to the recessive bus state and not the CAN driver.

A CAN receiver is required to output a recessive state when less than 500 mV of differential voltage exists on the bus, and a dominant state when more than 900 mV of differential voltage exists on the bus. The CAN receiver must do this with common-mode input voltages from -2 V to 7 volts per the ISO 11898-2 standard. The SN65HVD23x family receivers meet these same input specifications as 5 V supplied receivers.

11.3.1.2.1 Common Mode Signal

A common-mode signal is an average voltage of the two signal wires that the differential receiver rejects. The common-mode signal comes from the CAN driver, ground noise, and coupled bus noise. Since the bias voltage of the recessive state of the device is dependent on V_{CC} , any noise present or variation of V_{CC} will have an effect on this bias voltage seen by the bus. The SN65HVD23x family has the recessive bias voltage set higher than $0.5 \cdot V_{CC}$ to comply with the ISO 11898-2 CAN standard which states that the recessive bias voltage must be between 2 V and 3 V. The caveat to this is that the common mode voltage will drop by a couple hundred millivolts when driving a dominant bit on the bus. This means that there is a common mode shift between the dominant bit and recessive bit states of the device. While this is not ideal, this small variation in the driver common-mode output is rejected by differential receivers and does not effect data, signal noise margins or error rates.

11.3.1.3 Interoperability of 3.3-V CAN in 5-V CAN Systems

The 3.3 V supplied SN65HVD23x family of CAN transceivers are fully compatible with 5 V CAN transceivers. The differential output voltage is the same, the recessive common mode output bias is the same, and the receivers have the same input specifications. The only difference is in the dominant common mode output voltage is lower in 3.3 V CAN transceivers than with 5 V supplied transceiver (by a few hundred millivolts).

To help ensure the widest interoperability possible, the SN65HVD23x family has successfully passed the internationally recognized GIFT ICT conformance and interoperability testing for CAN transceivers which is shown in . Electrical interoperability does not always assure interchangeability however. Most implementers of CAN buses recognize that ISO 11898 does not sufficiently specify the electrical layer and that strict standard compliance alone does not ensure full interchangeability. This comes only with thorough equipment testing.

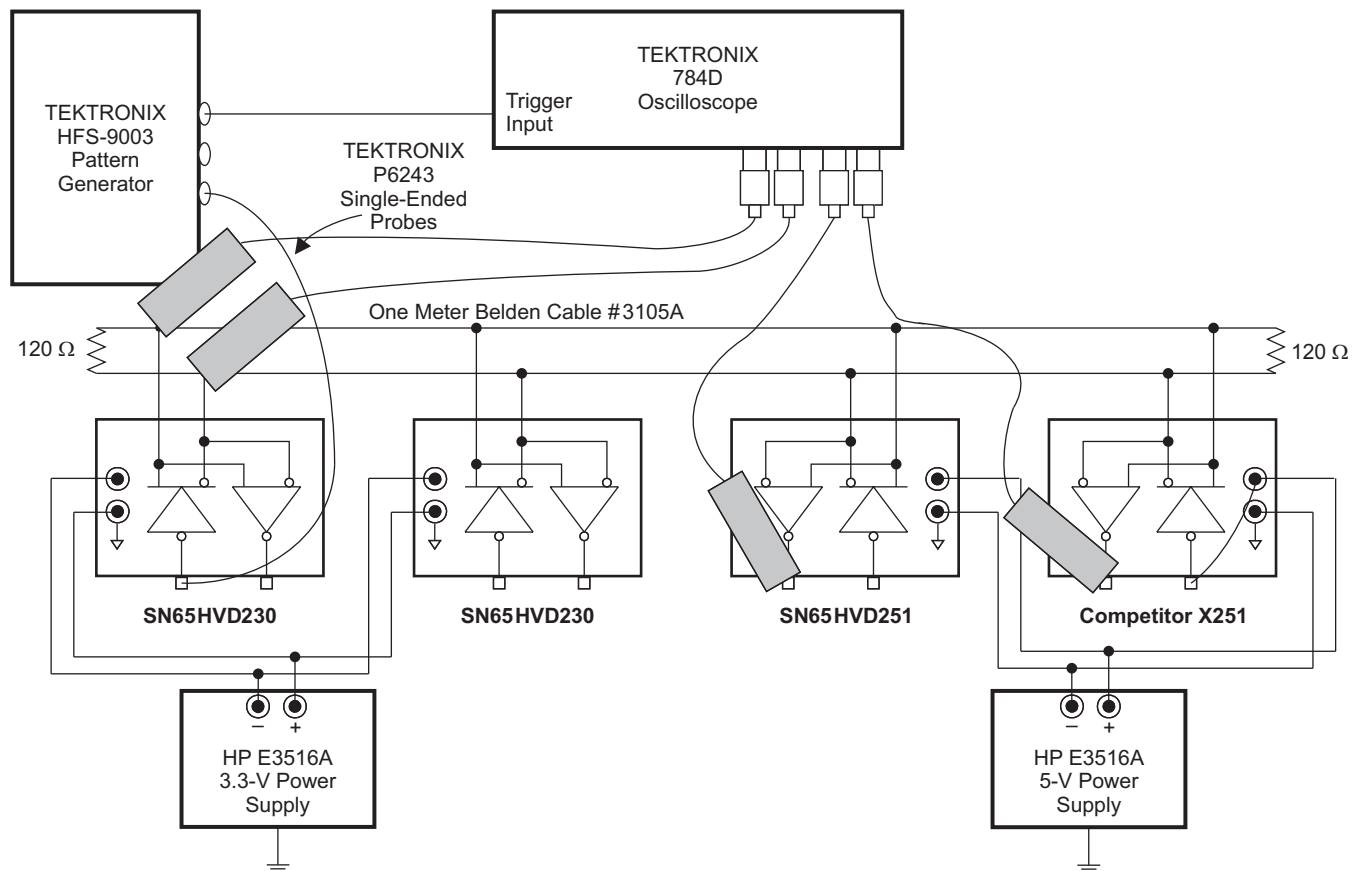
System Example (continued)

Figure 43. 3.3-V and 5-V CAN Transceiver System Testing

12 Power Supply Recommendations

The SN65HVD23x 3.3 V CAN transceivers provide the interface between the 3.3 V μ Ps, MCUs and DSPs and the differential bus lines, and are designed to transmit data at signaling rates up to 1 Mbps as defined by the ISO 11898 standard.

To ensure reliable operation at all data rates and supply voltages, the V_{CC} supply pin of each CAN transceiver should be decoupled with a 100-nF ceramic capacitor located as close to the V_{CC} and GND pins as possible. The TPS76333 is a linear voltage regulator suitable for supplying the 3.3-V supply.

13 Layout

13.1 Layout Guidelines

In order for the PCB design to be successful, start with design of the protection and filtering circuitry. Because ESD and EFT transients have a wide frequency bandwidth from approximately 3 MHz to 3 GHz, high frequency layout techniques must be applied during PCB design. On chip IEC ESD protection is good for laboratory and portable equipment but is usually not sufficient for EFT and surge transients occurring in industrial environments. Therefore robust and reliable bus node design requires the use of external transient protection devices at the bus connectors. Placement at the connector also prevents these harsh transient events from propagating further into the PCB and system.

Use V_{CC} and ground planes to provide low inductance. Note: high frequency current follows the path of least inductance and not the path of least resistance.

Design the bus protection components in the direction of the signal path. Do not force the transient current to divert from the signal path to reach the protection device.

An example placement of the Transient Voltage Suppression (TVS) device indicated as D1 (either bi-directional diode or varistor solution) and bus filter capacitors C8 and C9 are shown in .

The bus transient protection and filtering components should be placed as close to the bus connector, J1, as possible. This prevents transients, ESD and noise from penetrating onto the board and disturbing other devices.

Bus termination: [Figure 44](#) shows split termination. This is where the termination is split into two resistors, R7 and R8, with the center or split tap of the termination connected to ground via capacitor C7. Split termination provides common mode filtering for the bus. When termination is placed on the board instead of directly on the bus, care must be taken to ensure the terminating node is not removed from the bus as this will cause signal integrity issues of the bus is not properly terminated on both ends. See the application section for information on power ratings needed for the termination resistor(s).

Bypass and bulk capacitors should be placed as close as possible to the supply pins of transceiver, examples C2, C3 (V_{CC}).

Use at least two vias for V_{CC} and ground connections of bypass capacitors and protection devices to minimize trace and via inductance.

To limit current of digital lines, serial resistors may be used. Examples are R1, R2, R3 and R4.

To filter noise on the digital IO lines, a capacitor may be used close to the input side of the IO as shown by C1 and C4.

Since the internal pull up and pull down biasing of the device is weak for floating pins, an external 1k to 10k ohm pull-up or down resistor should be used to bias the state of the pin more strongly against noise during transient events.

Pin 1: If an open drain host processor is used to drive the D pin of the device an external pull-up resistor between 1k and 10k ohms should be used to drive the recessive input state of the device (R1).

Pin 8: is shown assuming the mode pin, RS, will be used. If the device will only be used in normal mode or slope control mode, R3 is not needed and the pads of C4 could be used for the pull down resistor to GND.

Pin 5 in is shown for the SN65HVD230 and SN65HVD231 devices which have a V_{ref} output voltage reference. If used, this pin should be tied to the common mode point of the split termination. If this feature is not used, the pin can be left floating.

For the SN65HVD232, pins 5 and 8 are no connect (NC) pin. This means that the pins are not internally connected and can be left floating.

13.2 Layout Example

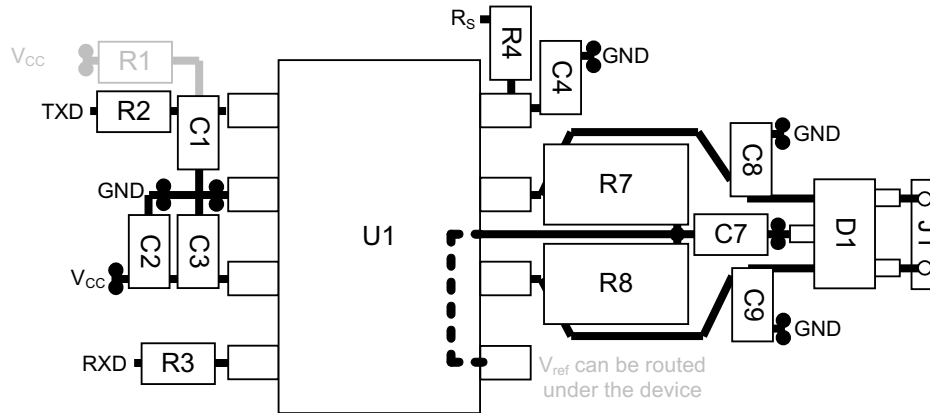

Figure 44. SN65HVD23x Board Layout

14 Device and Documentation Support

14.1 Related Links

The table below lists quick access links. Categories include technical documents, support and community resources, tools and software, and quick access to sample or buy.

Table 8. Related Links

PARTS	PRODUCT FOLDER	SAMPLE & BUY	TECHNICAL DOCUMENTS	TOOLS & SOFTWARE	SUPPORT & COMMUNITY
SN65HVD230	Click here	Click here	Click here	Click here	Click here
SN65HVD231	Click here	Click here	Click here	Click here	Click here
SN65HVD232	Click here	Click here	Click here	Click here	Click here

14.2 Receiving Notification of Documentation Updates

To receive notification of documentation updates, navigate to the device product folder on ti.com. In the upper right corner, click on *Alert me* to register and receive a weekly digest of any product information that has changed. For change details, review the revision history included in any revised document.

14.3 Community Resources

The following links connect to TI community resources. Linked contents are provided "AS IS" by the respective contributors. They do not constitute TI specifications and do not necessarily reflect TI's views; see TI's [Terms of Use](#).

TI E2E™ Online Community *TI's Engineer-to-Engineer (E2E) Community*. Created to foster collaboration among engineers. At e2e.ti.com, you can ask questions, share knowledge, explore ideas and help solve problems with fellow engineers.

Design Support *TI's Design Support* Quickly find helpful E2E forums along with design support tools and contact information for technical support.

14.4 Trademarks

E2E is a trademark of Texas Instruments.
All other trademarks are the property of their respective owners.

14.5 Electrostatic Discharge Caution



These devices have limited built-in ESD protection. The leads should be shorted together or the device placed in conductive foam during storage or handling to prevent electrostatic damage to the MOS gates.

14.6 Glossary

[SLYZ022](#) — *TI Glossary*.

This glossary lists and explains terms, acronyms, and definitions.

15 Mechanical, Packaging, and Orderable Information

The following pages include mechanical, packaging, and orderable information. This information is the most current data available for the designated devices. This data is subject to change without notice and revision of this document. For browser-based versions of this data sheet, refer to the left-hand navigation.

PACKAGING INFORMATION

Orderable Device	Status (1)	Package Type	Package Drawing	Pins	Package Qty	Eco Plan (2)	Lead finish/ Ball material (6)	MSL Peak Temp (3)	Op Temp (°C)	Device Marking (4/5)	Samples
SN65HVD230DR	ACTIVE	SOIC	D	8	2500	RoHS & Green	NIPDAU	Level-1-260C-UNLIM	-40 to 85	VP230	Samples
SN65HVD230DRG4	ACTIVE	SOIC	D	8	2500	RoHS & Green	NIPDAU	Level-1-260C-UNLIM	-40 to 85	VP230	Samples
SN65HVD231DR	ACTIVE	SOIC	D	8	2500	RoHS & Green	NIPDAU	Level-1-260C-UNLIM	-40 to 85	VP231	Samples
SN65HVD231DRG4	ACTIVE	SOIC	D	8	2500	RoHS & Green	NIPDAU	Level-1-260C-UNLIM	-40 to 85	VP231	Samples
SN65HVD232DR	ACTIVE	SOIC	D	8	2500	RoHS & Green	NIPDAU	Level-1-260C-UNLIM	-40 to 85	VP232	Samples
SN65HVD232DRG4	ACTIVE	SOIC	D	8	2500	RoHS & Green	NIPDAU	Level-1-260C-UNLIM	-40 to 85	VP232	Samples

(1) The marketing status values are defined as follows:

ACTIVE: Product device recommended for new designs.

LIFEBUY: TI has announced that the device will be discontinued, and a lifetime-buy period is in effect.

NRND: Not recommended for new designs. Device is in production to support existing customers, but TI does not recommend using this part in a new design.

PREVIEW: Device has been announced but is not in production. Samples may or may not be available.

OBSOLETE: TI has discontinued the production of the device.

(2) **RoHS:** TI defines "RoHS" to mean semiconductor products that are compliant with the current EU RoHS requirements for all 10 RoHS substances, including the requirement that RoHS substance do not exceed 0.1% by weight in homogeneous materials. Where designed to be soldered at high temperatures, "RoHS" products are suitable for use in specified lead-free processes. TI may reference these types of products as "Pb-Free".

RoHS Exempt: TI defines "RoHS Exempt" to mean products that contain lead but are compliant with EU RoHS pursuant to a specific EU RoHS exemption.

Green: TI defines "Green" to mean the content of Chlorine (Cl) and Bromine (Br) based flame retardants meet JS709B low halogen requirements of <=1000ppm threshold. Antimony trioxide based flame retardants must also meet the <=1000ppm threshold requirement.

(3) MSL, Peak Temp. - The Moisture Sensitivity Level rating according to the JEDEC industry standard classifications, and peak solder temperature.

(4) There may be additional marking, which relates to the logo, the lot trace code information, or the environmental category on the device.

(5) Multiple Device Markings will be inside parentheses. Only one Device Marking contained in parentheses and separated by a "-" will appear on a device. If a line is indented then it is a continuation of the previous line and the two combined represent the entire Device Marking for that device.

(6) Lead finish/Ball material - Orderable Devices may have multiple material finish options. Finish options are separated by a vertical ruled line. Lead finish/Ball material values may wrap to two lines if the finish value exceeds the maximum column width.

Important Information and Disclaimer: The information provided on this page represents TI's knowledge and belief as of the date that it is provided. TI bases its knowledge and belief on information provided by third parties, and makes no representation or warranty as to the accuracy of such information. Efforts are underway to better integrate information from third parties. TI has taken and continues to take reasonable steps to provide representative and accurate information but may not have conducted destructive testing or chemical analysis on incoming materials and chemicals. TI and TI suppliers consider certain information to be proprietary, and thus CAS numbers and other limited information may not be available for release.

In no event shall TI's liability arising out of such information exceed the total purchase price of the TI part(s) at issue in this document sold by TI to Customer on an annual basis.

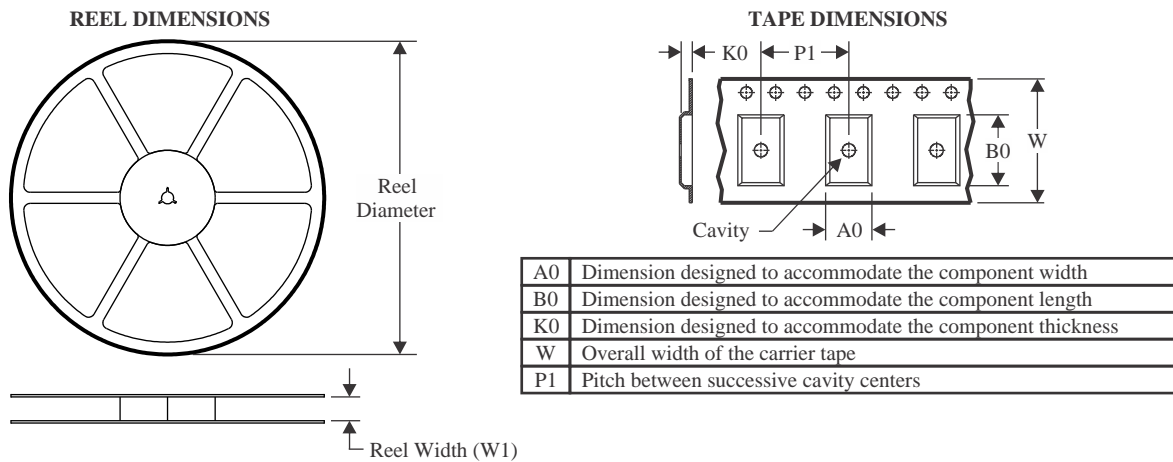
TAPE AND REEL INFORMATION

QUADRANT ASSIGNMENTS FOR PIN 1 ORIENTATION IN TAPE

*All dimensions are nominal

Device	Package Type	Package Drawing	Pins	SPQ	Reel Diameter (mm)	Reel Width W1 (mm)	A0 (mm)	B0 (mm)	K0 (mm)	P1 (mm)	W (mm)	Pin1 Quadrant
SN65HVD230DR	SOIC	D	8	2500	330.0	12.4	6.4	5.2	2.1	8.0	12.0	Q1
SN65HVD231DR	SOIC	D	8	2500	330.0	12.4	6.4	5.2	2.1	8.0	12.0	Q1
SN65HVD232DR	SOIC	D	8	2500	330.0	12.4	6.4	5.2	2.1	8.0	12.0	Q1

TAPE AND REEL BOX DIMENSIONS

*All dimensions are nominal

Device	Package Type	Package Drawing	Pins	SPQ	Length (mm)	Width (mm)	Height (mm)
SN65HVD230DR	SOIC	D	8	2500	340.5	338.1	20.6
SN65HVD231DR	SOIC	D	8	2500	340.5	338.1	20.6
SN65HVD232DR	SOIC	D	8	2500	340.5	338.1	20.6



D0008A

PACKAGE OUTLINE

SOIC - 1.75 mm max height

SMALL OUTLINE INTEGRATED CIRCUIT



NOTES:

1. Linear dimensions are in inches [millimeters]. Dimensions in parenthesis are for reference only. Controlling dimensions are in inches. Dimensioning and tolerancing per ASME Y14.5M.
2. This drawing is subject to change without notice.
3. This dimension does not include mold flash, protrusions, or gate burrs. Mold flash, protrusions, or gate burrs shall not exceed $.006$ [0.15] per side.
4. This dimension does not include interlead flash.
5. Reference JEDEC registration MS-012, variation AA.

EXAMPLE BOARD LAYOUT

D0008A

SOIC - 1.75 mm max height

SMALL OUTLINE INTEGRATED CIRCUIT



LAND PATTERN EXAMPLE
EXPOSED METAL SHOWN
SCALE:8X



SOLDER MASK DETAILS

4214825/C 02/2019

NOTES: (continued)

- 6. Publication IPC-7351 may have alternate designs.
- 7. Solder mask tolerances between and around signal pads can vary based on board fabrication site.

EXAMPLE STENCIL DESIGN

D0008A

SOIC - 1.75 mm max height

SMALL OUTLINE INTEGRATED CIRCUIT



SOLDER PASTE EXAMPLE
BASED ON .005 INCH [0.125 MM] THICK STENCIL
SCALE:8X

4214825/C 02/2019

NOTES: (continued)

8. Laser cutting apertures with trapezoidal walls and rounded corners may offer better paste release. IPC-7525 may have alternate design recommendations.
9. Board assembly site may have different recommendations for stencil design.

IMPORTANT NOTICE AND DISCLAIMER

TI PROVIDES TECHNICAL AND RELIABILITY DATA (INCLUDING DATA SHEETS), DESIGN RESOURCES (INCLUDING REFERENCE DESIGNS), APPLICATION OR OTHER DESIGN ADVICE, WEB TOOLS, SAFETY INFORMATION, AND OTHER RESOURCES "AS IS" AND WITH ALL FAULTS, AND DISCLAIMS ALL WARRANTIES, EXPRESS AND IMPLIED, INCLUDING WITHOUT LIMITATION ANY IMPLIED WARRANTIES OF MERCHANTABILITY, FITNESS FOR A PARTICULAR PURPOSE OR NON-INFRINGEMENT OF THIRD PARTY INTELLECTUAL PROPERTY RIGHTS.

These resources are intended for skilled developers designing with TI products. You are solely responsible for (1) selecting the appropriate TI products for your application, (2) designing, validating and testing your application, and (3) ensuring your application meets applicable standards, and any other safety, security, regulatory or other requirements.

These resources are subject to change without notice. TI grants you permission to use these resources only for development of an application that uses the TI products described in the resource. Other reproduction and display of these resources is prohibited. No license is granted to any other TI intellectual property right or to any third party intellectual property right. TI disclaims responsibility for, and you will fully indemnify TI and its representatives against, any claims, damages, costs, losses, and liabilities arising out of your use of these resources.

TI's products are provided subject to [TI's Terms of Sale](#) or other applicable terms available either on [ti.com](https://www.ti.com) or provided in conjunction with such TI products. TI's provision of these resources does not expand or otherwise alter TI's applicable warranties or warranty disclaimers for TI products.

TI objects to and rejects any additional or different terms you may have proposed.

Mailing Address: Texas Instruments, Post Office Box 655303, Dallas, Texas 75265
Copyright © 2024, Texas Instruments Incorporated

Looking for pricing, stock, or lifecycle information?

Click below to explore more details on WIN SOURCE:

 [View SN65HVD230DR on WIN SOURCE](#)

 [Texas Instruments](#) Information

Optimize Your Supply Chain with WIN SOURCE Solutions

-  Global Sourcing Solution
-  Obsolete Management
-  Cost Control Management
-  Shortage Management
-  Alternative Solution
-  Excess Inventory Management