



THE DATASHEET OF SN74ACT245PWR



Table of Contents

| | | | |
|--|---|--|----|
| 1 Features | 1 | 7.3 Feature Description..... | 9 |
| 2 Applications | 1 | 7.4 Device Functional Modes..... | 9 |
| 3 Description | 1 | 8 Application Information Disclaimer | 10 |
| 4 Pin Configuration and Functions | 3 | 8.1 Application Information..... | 10 |
| 5 Specifications | 5 | 8.2 Typical Application..... | 10 |
| 5.1 Absolute Maximum Ratings | 5 | 8.3 Power Supply Recommendations..... | 11 |
| 5.2 ESD Ratings..... | 5 | 8.4 Layout..... | 11 |
| 5.3 Recommended Operating Conditions..... | 5 | 9 Device and Documentation Support | 12 |
| 5.4 Thermal Information..... | 5 | 9.1 Documentation Support..... | 12 |
| 5.5 Electrical Characteristics..... | 6 | 9.2 Receiving Notification of Documentation Updates.... | 12 |
| 5.6 Switching Characteristics..... | 6 | 9.3 Support Resources..... | 12 |
| 5.7 Operating Characteristics..... | 6 | 9.4 Trademarks..... | 12 |
| 5.8 Typical Characteristics..... | 7 | 9.5 Electrostatic Discharge Caution..... | 12 |
| 6 Parameter Measurement Information | 8 | 9.6 Glossary..... | 12 |
| 7 Detailed Description | 9 | 10 Revision History | 13 |
| 7.1 Overview..... | 9 | 11 Mechanical, Packaging, and Orderable Information | 13 |
| 7.2 Functional Block Diagram..... | 9 | | |

4 Pin Configuration and Functions

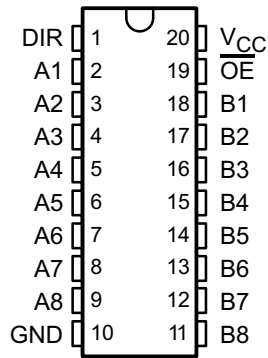

**Figure 4-1. SN54ACT245 J or W Package;
 SN74ACT245 DB, DGS, DW, N, NS, or PW Package
 Top View**

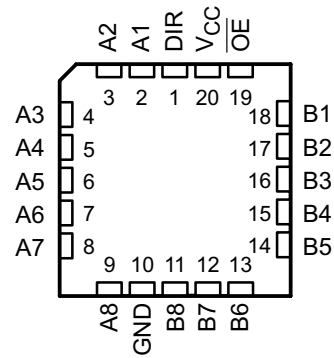

Figure 4-2. SN54ACT245 FK Package Top View

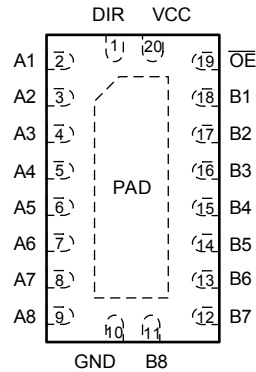

Figure 4-3. SN54ACT245 RKS Package Top View

Pin Functions

| PIN | | TYPE ¹ | DESCRIPTION |
|-----|------|-------------------|-----------------|
| NO. | NAME | | |
| 1 | DIR | I/O | Direction Pin |
| 2 | A1 | I/O | A1 Input/Output |
| 3 | A2 | I/O | A2 Input/Output |
| 4 | A3 | I/O | A3 Input/Output |
| 5 | A4 | I/O | A4 Input/Output |
| 6 | A5 | I/O | A5 Input/Output |
| 7 | A6 | I/O | A6 Input/Output |
| 8 | A7 | I/O | A7 Input/Output |
| 9 | A8 | I/O | A8 Input/Output |
| 10 | GND | — | Ground Pin |
| 11 | B8 | I/O | B8 Input/Output |
| 12 | B7 | I/O | B7 Input/Output |
| 13 | B6 | I/O | B6 Input/Output |
| 14 | B5 | I/O | B5 Input/Output |
| 15 | B4 | I/O | B4 Input/Output |
| 16 | B3 | I/O | B3 Input/Output |
| 17 | B2 | I/O | B2 Input/Output |
| 18 | B1 | I/O | B1 Input/Output |
| 19 | OE | I/O | Output Enable |
| 20 | VCC | — | Power Pin |

(1) Signal Types: I = Input, O = Output, I/O = Input or Output

5 Specifications

5.1 Absolute Maximum Ratings

over operating free-air temperature range (unless otherwise noted)

| | | MIN | MAX | UNIT |
|---|-------------------------------|--|-----------------------|---------|
| V _{CC} | Supply voltage | -0.5 | 7 | V |
| V _I | Input voltage ⁽¹⁾ | -0.5 | V _{CC} + 0.5 | V |
| V _O | Output voltage ⁽¹⁾ | -0.5 | V _{CC} + 0.5 | V |
| I _{IK} | Input clamp current | V _I < 0 or V _I > V _{CC} | | ±20 mA |
| I _{OK} | Output clamp current | V _O < 0 or V _O > V _{CC} | | ±20 mA |
| I _O | Continuous output current | V _O = 0 to V _{CC} | | ±50 mA |
| Continuous current through V _{CC} or GND | | | | ±200 mA |
| T _{stg} | Storage temperature range | -65 | 150 | °C |

(1) The input and output voltage ratings may be exceeded if the input and output current ratings are observed.

5.2 ESD Ratings

| | | VALUE | UNIT |
|--------------------|-------------------------|--|-------|
| V _(ESD) | Electrostatic discharge | Human body model (HBM), per ANSI/ESDA/JEDEC JS-001 ⁽¹⁾ | ±3000 |
| | | Charged-device model (CDM), per JEDEC specification JESD22-C101 ⁽²⁾ | ±1000 |

(1) JEDEC document JEP155 states that 500-V HBM allows safe manufacturing with a standard ESD control process.

(2) JEDEC document JEP157 states that 250-V CDM allows safe manufacturing with a standard ESD control process.

5.3 Recommended Operating Conditions

| | | SN54ACT245 | | SN74ACT245 | | UNIT |
|-----------------|------------------------------------|------------|-----------------|------------|-----------------|------|
| | | MIN | MAX | MIN | MAX | |
| V _{CC} | Supply voltage | 4.5 | 5.5 | 4.5 | 5.5 | V |
| V _{IH} | High-level input voltage | 2 | | 2 | | V |
| V _{IL} | Low-level input voltage | | 0.8 | | 0.8 | V |
| V _I | Input voltage | 0 | V _{CC} | 0 | V _{CC} | V |
| V _O | Output voltage | 0 | V _{CC} | 0 | V _{CC} | V |
| I _{OH} | High-level output current | | -24 | | -24 | mA |
| I _{OL} | Low-level output current | | 24 | | 24 | mA |
| Δt/Δv | Input transition rise or fall rate | | 8 | | 8 | ns/V |
| T _A | Operating free-air temperature | -55 | 125 | -40 | 85 | °C |

5.4 Thermal Information

| THERMAL METRIC ⁽¹⁾ | | SNx4ACT245 | | | | | | | UNIT |
|-------------------------------|--|------------|-------------|-----------|----------|----------|------------|------------|------|
| | | DB (SSOP) | DGS (VSSOP) | DW (SOIC) | N (PDIP) | NS (SOP) | PW (TSSOP) | RKS (VQFN) | |
| | | 20 PINS | | | | | | | |
| R _{θJA} | Junction-to-ambient thermal resistance | 105.4 | 123.5 | 98.6 | 69 | 99.7 | 126.6 | 67.7 | °C/W |

(1) For more information about traditional and new thermal metrics, see the *Semiconductor and IC Package Thermal Metrics* application report, [SPRA953](#).

5.5 Electrical Characteristics

over recommended operating free-air temperature range (unless otherwise noted)

| PARAMETER | TEST CONDITIONS | V _{CC} | T _A = 25°C | | | SN54ACT245 | | SN74ACT245 | | UNIT | |
|---|---|---|-----------------------|-------|------|------------|------|------------|------|------|----|
| | | | MIN | TYP | MAX | MIN | MAX | MIN | MAX | | |
| V _{OH} | I _{OH} = -50 μA | 4.5 V | 4.4 | 4.49 | | 4.4 | | 4.4 | V | | |
| | | 5.5 V | 5.4 | 5.49 | | 5.4 | | 5.4 | | | |
| | I _{OH} = -24 mA | 4.5 V | | 3.88 | | 3.7 | | 3.76 | | | |
| | | 5.5 V | | 4.86 | | 4.7 | | 4.76 | | | |
| | I _{OH} = -50 mA ⁽¹⁾ | 5.5 V | | | | 3.85 | | | | | |
| I _{OH} = -75 mA ⁽¹⁾ | 5.5 V | | | | | | 3.85 | | | | |
| V _{OL} | I _{OL} = 50 μA | 4.5 V | | 0.001 | 0.1 | | 0.1 | | 0.1 | | |
| | | 5.5 V | | 0.001 | 0.1 | | 0.1 | | 0.1 | | |
| | I _{OL} = 24 mA | 4.5 V | | | 0.36 | | 0.5 | | 0.44 | | |
| | | 5.5 V | | | 0.36 | | 0.5 | | 0.44 | | |
| | I _{OL} = 50 mA ⁽¹⁾ | 5.5 V | | | | | 1.65 | | | | |
| I _{OL} = 75 mA ⁽¹⁾ | 5.5 V | | | | | | | 1.65 | | | |
| I _{OZ} | A or B ports ⁽²⁾ | V _O = V _{CC} or GND | 5.5 V | | | ±0.5 | | ±10 | | ±5 | μA |
| I _I | \overline{OE} or DIR | V _I = V _{CC} or GND | 5.5 V | | | ±0.1 | | ±1 | | ±1 | μA |
| I _{CC} | | V _I = V _{CC} or GND, I _O = 0 | 5.5 V | | | 4 | | 80 | | 40 | μA |
| ΔI _{CC} ⁽³⁾ | | One input at 3.4 V, Other inputs at GND or V _{CC} | 5.5 V | | 0.6 | | | 1.6 | | 1.5 | mA |
| C _i | | V _I = V _{CC} or GND | 5 V | | 4.5 | | | | | | pF |
| C _{io} | | V _O = V _{CC} or GND | 5 V | | 15 | | | | | | pF |

(1) Not more than one output should be tested at a time, and the duration of the test should not exceed 2 ms.

(2) For I/O ports, the parameter I_{OZ} includes the input leakage current.

(3) This is the increase in supply current for each input that is at one of the specified TTL voltage levels, rather than 0 V or V_{CC}.

5.6 Switching Characteristics

over recommended operating free-air temperature range, V_{CC} = 5 V ± 0.5 V (unless otherwise noted) (see Figure 6-1)

| PARAMETER | FROM (INPUT) | TO (OUTPUT) | T _A = 25°C | | | SN54ACT245 | | SN74ACT245 | | UNIT |
|------------------|-----------------|-------------|-----------------------|-----|-----|------------|-----|------------|-----|------|
| | | | MIN | TYP | MAX | MIN | MAX | MIN | MAX | |
| t _{PLH} | A or B | B or A | 1 | 4 | 7.5 | 1 | 9 | 1.5 | 8 | ns |
| t _{PHL} | | | 1 | 4 | 8 | 1 | 10 | 1 | 9 | |
| t _{PZH} | \overline{OE} | A or B | 1 | 5 | 10 | 1 | 12 | 1.5 | 11 | ns |
| t _{PZL} | | | 1 | 5.5 | 10 | 1 | 13 | 1.5 | 12 | |
| t _{PHZ} | \overline{OE} | A or B | 1 | 5.5 | 10 | 1 | 12 | 1 | 11 | ns |
| t _{PLZ} | | | 1 | 5 | 10 | 1 | 12 | 1.5 | 11 | |

5.7 Operating Characteristics

V_{CC} = 5 V, T_A = 25°C

| PARAMETER | TEST CONDITIONS | TYP | UNIT |
|---|-----------------------------------|-----|------|
| C _{pd} Power dissipation capacitance | C _L = 50 pF, f = 1 MHz | 45 | pF |

5.8 Typical Characteristics

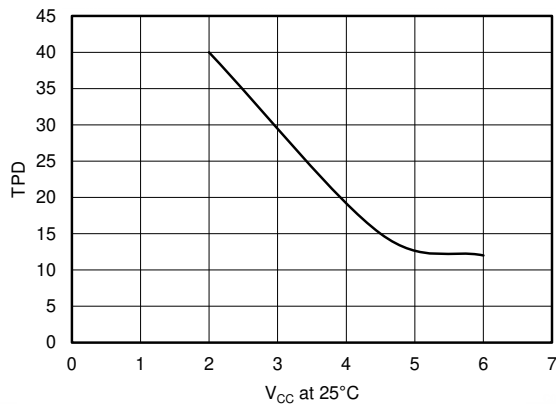

Figure 5-1. TPD vs V_{CC} at 25°C

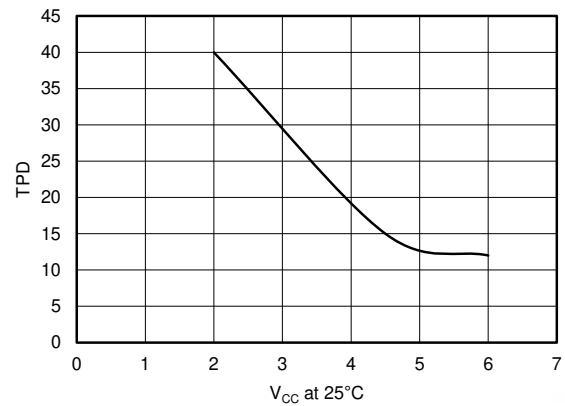
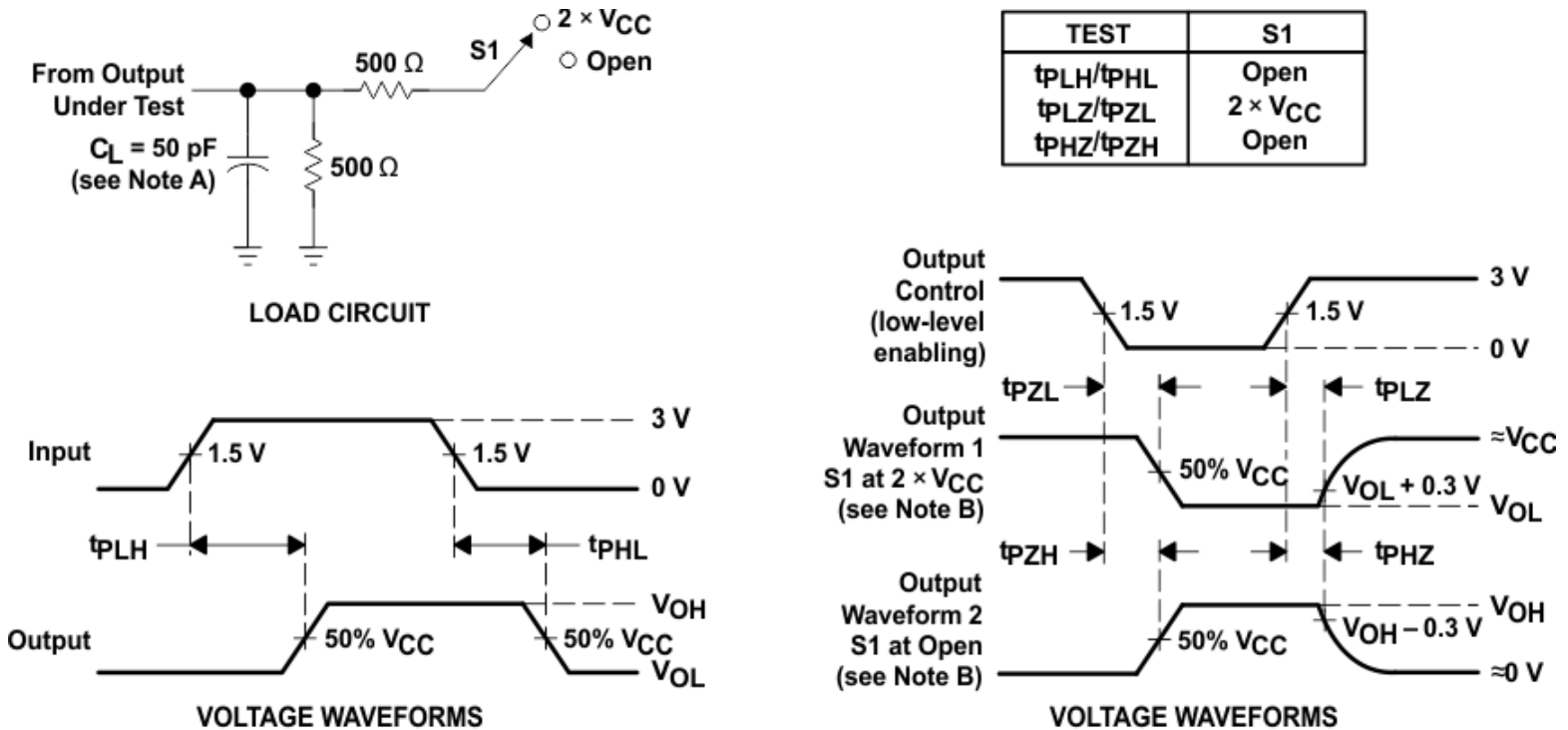

Figure 5-2. TPD vs V_{CC} at 25°C

6 Parameter Measurement Information

6.1



- NOTES:
- A. C_L includes probe and jig capacitance.
 - B. Waveform 1 is for an output with internal conditions such that the output is low except when disabled by the output control. Waveform 2 is for an output with internal conditions such that the output is high except when disabled by the output control.
 - C. All input pulses are supplied by generators having the following characteristics: $PRR \leq 1 \text{ MHz}$, $Z_O = 50 \Omega$, $t_r \leq 2.5 \text{ ns}$, $t_f \leq 2.5 \text{ ns}$.
 - D. The outputs are measured one at a time with one input transition per measurement.

Figure 6-1. Load Circuit and Voltage Waveforms

7 Detailed Description

7.1 Overview

These octal bus transceivers are designed for asynchronous two-way communication between data buses. The control-function implementation minimizes external timing requirements.

When the output-enable (\overline{OE}) is low, the device passes noninverted data from the A bus to the B bus or from the B bus to the A bus, depending upon the logic level at the direction-control (DIR) input. A high on \overline{OE} disables the device so that the buses are effectively isolated.

To ensure the high-impedance state during power up or power down, \overline{OE} should be tied to V_{CC} through a pullup resistor; the minimum value of the resistor is determined by the current-sinking capability of the driver.

7.2 Functional Block Diagram

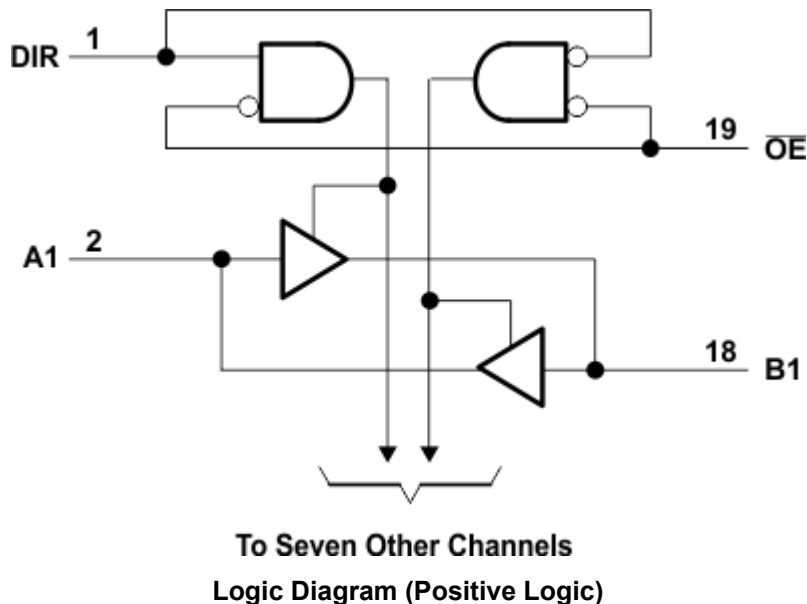

7.3 Feature Description

The SNx4ACT245 devices have a wide operating V_{CC} range from 4.5 V to 5.5 V with slower edge rates to minimize output ringing.

7.4 Device Functional Modes

Section 7.4 lists the function modes of the SNx4ACT245.

Table 7-1. Function Table

| INPUTS ⁽¹⁾ | | OPERATION |
|-----------------------|-----|-----------------|
| \overline{OE} | DIR | |
| L | L | B data to A bus |
| L | H | A data to B bus |
| H | X | Isolation |

(1) H = High Voltage Level, L = Low Voltage Level, X = Don't Care

8 Application Information Disclaimer

Note

Information in the following applications sections is not part of the TI component specification, and TI does not warrant its accuracy or completeness. TI's customers are responsible for determining suitability of components for their purposes, as well as validating and testing their design implementation to confirm system functionality.

8.1 Application Information

The SNx4ACT245 is a low-drive CMOS device that can be used for a multitude of bus interface type applications where output ringing is a concern. The low drive and slow edge rates will minimize overshoot and undershoot on the outputs.

8.2 Typical Application

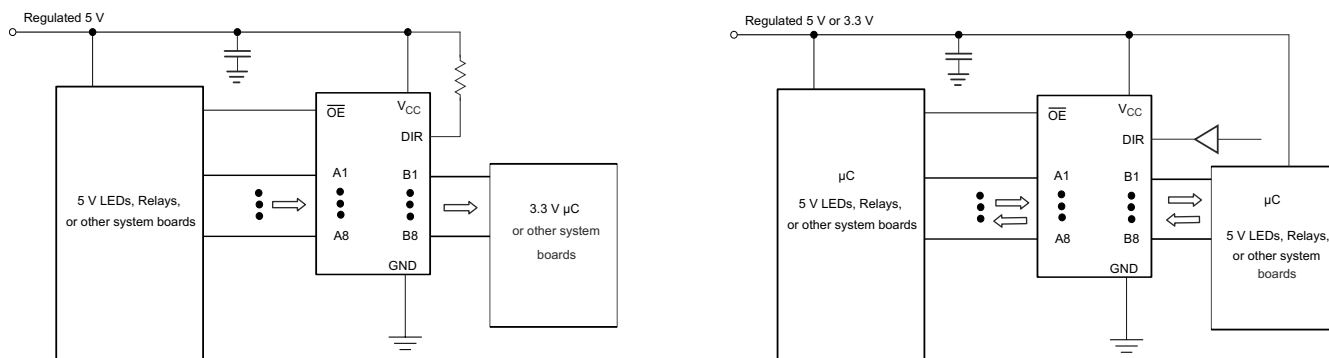

Figure 8-1. Typical Application Schematic

8.2.1 Design Requirements

This device uses CMOS technology and has balanced output drive. Care should be taken to avoid bus contention because it can drive currents that would exceed maximum limits. The high drive will also create fast edges into light loads, so routing and load conditions should be considered to prevent ringing.

8.2.2 Detailed Design Procedure

- Recommended Input Conditions
 - For rise time and fall time specifications, see $\Delta t/\Delta V$ in the [Section 5.3](#) table.
 - For specified High and low levels, see V_{IH} and V_{IL} in the [Section 5.3](#) table.
 - Inputs are overvoltage tolerant allowing them to go as high as 5.5 V at any valid V_{CC} .
- Recommend Output Conditions
 - Load currents should not exceed 35 mA per output and 70 mA total for the part.
 - Outputs should not be pulled above V_{CC} .

8.2.3 Application Curve

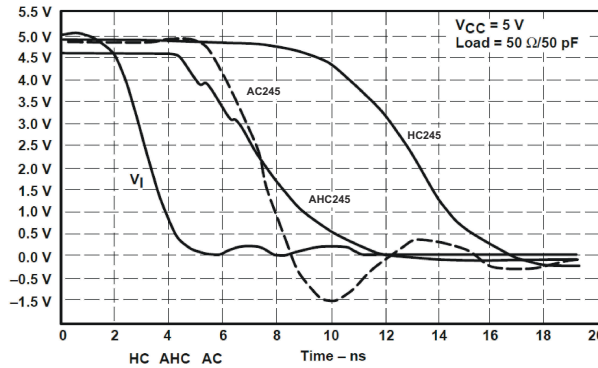

Figure 8-2. Switching Characteristics Comparison

8.3 Power Supply Recommendations

The power supply can be any voltage between the MIN and MAX supply voltage rating located in the [Section 5.3](#).

Each V_{CC} pin should have a good bypass capacitor to prevent power disturbance. For devices with a single supply, 0.1 μF is recommended; if there are multiple V_{CC} pins, then 0.01 μF or 0.022 μF is recommended for each power pin. It is acceptable to parallel multiple bypass caps to reject different frequencies of noise. A 0.1 μF and a 1 μF are commonly used in parallel. The bypass capacitor should be installed as close to the power pin as possible for best results.

8.4 Layout

8.4.1 Layout Guidelines

When using multiple-bit logic devices, inputs should never float.

In many cases, functions or parts of functions of digital logic devices are unused, for example, when only two inputs of a triple-input AND gate are used or only 3 of the 4 buffer gates are used. Such input pins should not be left unconnected because the undefined voltages at the outside connections result in undefined operational states. [Section 8.4.2](#) specifies the rules that must be observed under all circumstances. All unused inputs of digital logic devices must be connected to a high or low bias to prevent them from floating. The logic level that should be applied to any particular unused input depends on the function of the device. Generally they will be tied to GND or V_{CC} , whichever makes more sense or is more convenient. It is generally acceptable to float outputs, unless the part is a transceiver. If the transceiver has an output enable pin, it will disable the output section of the part when asserted. This will not disable the input section of the IOs, so they cannot float when disabled.

8.4.2 Layout Example

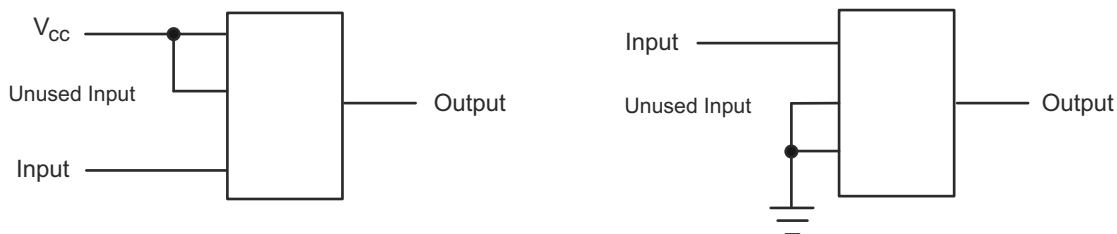

Figure 8-3. Layout Diagram

9 Device and Documentation Support

9.1 Documentation Support

9.1.1 Related Links

The table below lists quick access links. Categories include technical documents, support and community resources, tools and software, and quick access to sample or buy.

Table 9-1. Related Links

| PARTS | PRODUCT FOLDER | SAMPLE & BUY | TECHNICAL DOCUMENTS | TOOLS & SOFTWARE | SUPPORT & COMMUNITY |
|------------|----------------------------|----------------------------|----------------------------|----------------------------|----------------------------|
| SN54ACT245 | Click here | Click here | Click here | Click here | Click here |
| SN74ACT245 | Click here | Click here | Click here | Click here | Click here |

9.2 Receiving Notification of Documentation Updates

To receive notification of documentation updates, navigate to the device product folder on ti.com. Click on *Notifications* to register and receive a weekly digest of any product information that has changed. For change details, review the revision history included in any revised document.

9.3 Support Resources

[TI E2E™ support forums](#) are an engineer's go-to source for fast, verified answers and design help — straight from the experts. Search existing answers or ask your own question to get the quick design help you need.

Linked content is provided "AS IS" by the respective contributors. They do not constitute TI specifications and do not necessarily reflect TI's views; see TI's [Terms of Use](#).

9.4 Trademarks

TI E2E™ is a trademark of Texas Instruments.

All trademarks are the property of their respective owners.

9.5 Electrostatic Discharge Caution



This integrated circuit can be damaged by ESD. Texas Instruments recommends that all integrated circuits be handled with appropriate precautions. Failure to observe proper handling and installation procedures can cause damage.

ESD damage can range from subtle performance degradation to complete device failure. Precision integrated circuits may be more susceptible to damage because very small parametric changes could cause the device not to meet its published specifications.

9.6 Glossary

[TI Glossary](#)

This glossary lists and explains terms, acronyms, and definitions.

10 Revision History

NOTE: Page numbers for previous revisions may differ from page numbers in the current version.

Changes from Revision G (March 2024) to Revision H (April 2024) Page

- Updated R θ JA values: DB = 70 to 105.4, DW = 58 to 98.6, NS = 60 to 99.7, PW = 83 to 126.6, all values in °C/W 5
-

Changes from Revision F (January 2023) to Revision G (March 2024) Page

- Added DGS and RKS packages to *Device Information* table, *Pin Configuration and Functions* section and *Thermal Information* table..... 1
 - Changed *Package Information* to *Device Information* and added package size to table..... 1
-

11 Mechanical, Packaging, and Orderable Information

The following pages include mechanical, packaging, and orderable information. This information is the most current data available for the designated devices. This data is subject to change without notice and revision of this document. For browser-based versions of this data sheet, refer to the left-hand navigation.

PACKAGING INFORMATION

| Orderable Device | Status (1) | Package Type | Package Drawing | Pins | Package Qty | Eco Plan (2) | Lead finish/ Ball material (6) | MSL Peak Temp (3) | Op Temp (°C) | Device Marking (4/5) | Samples |
|------------------|---------------|--------------|-----------------|------|-------------|------------------|--------------------------------------|----------------------|--------------|--------------------------------------|-------------------------|
| 5962-8766301M2A | ACTIVE | LCCC | FK | 20 | 55 | Non-RoHS & Green | SNPB | N / A for Pkg Type | -55 to 125 | 5962-8766301M2A SNJ54 ACT245FK | Samples |
| 5962-8766301MRA | ACTIVE | CDIP | J | 20 | 20 | Non-RoHS & Green | SNPB | N / A for Pkg Type | -55 to 125 | 5962-8766301MR A SNJ54ACT245J | Samples |
| 5962-8766301MSA | ACTIVE | CFP | W | 20 | 25 | Non-RoHS & Green | SNPB | N / A for Pkg Type | -55 to 125 | 5962-8766301MS A SNJ54ACT245W | Samples |
| SN74ACT245DBR | ACTIVE | SSOP | DB | 20 | 2000 | RoHS & Green | NIPDAU | Level-1-260C-UNLIM | -40 to 85 | AD245 | Samples |
| SN74ACT245DGSR | ACTIVE | VSSOP | DGS | 20 | 5000 | RoHS & Green | NIPDAU | Level-1-260C-UNLIM | -40 to 85 | ACT245 | Samples |
| SN74ACT245DW | OBSOLETE | SOIC | DW | 20 | | TBD | Call TI | Call TI | -40 to 85 | ACT245 | |
| SN74ACT245DWR | ACTIVE | SOIC | DW | 20 | 2000 | RoHS & Green | NIPDAU | Level-1-260C-UNLIM | -40 to 85 | ACT245 | Samples |
| SN74ACT245DWRE4 | ACTIVE | SOIC | DW | 20 | 2000 | RoHS & Green | NIPDAU | Level-1-260C-UNLIM | -40 to 85 | ACT245 | Samples |
| SN74ACT245DWRG4 | ACTIVE | SOIC | DW | 20 | 2000 | RoHS & Green | NIPDAU | Level-1-260C-UNLIM | -40 to 85 | ACT245 | Samples |
| SN74ACT245N | ACTIVE | PDIP | N | 20 | 20 | RoHS & Green | NIPDAU | N / A for Pkg Type | -40 to 85 | SN74ACT245N | Samples |
| SN74ACT245NE4 | ACTIVE | PDIP | N | 20 | 20 | RoHS & Green | NIPDAU | N / A for Pkg Type | -40 to 85 | SN74ACT245N | Samples |
| SN74ACT245NS | ACTIVE | SO | NS | 20 | | TBD | Call TI | Call TI | -40 to 85 | ACT245 | Samples |
| SN74ACT245NSR | ACTIVE | SO | NS | 20 | 2000 | RoHS & Green | NIPDAU | Level-1-260C-UNLIM | -40 to 85 | ACT245 | Samples |
| SN74ACT245PW | OBSOLETE | TSSOP | PW | 20 | | TBD | Call TI | Call TI | -40 to 85 | AD245 | |
| SN74ACT245PWG4 | OBSOLETE | TSSOP | PW | 20 | | TBD | Call TI | Call TI | -40 to 85 | | |
| SN74ACT245PWR | ACTIVE | TSSOP | PW | 20 | 2000 | RoHS & Green | NIPDAU | Level-1-260C-UNLIM | -40 to 85 | AD245 | Samples |
| SN74ACT245PWRG4 | ACTIVE | TSSOP | PW | 20 | 2000 | RoHS & Green | NIPDAU | Level-1-260C-UNLIM | -40 to 85 | AD245 | Samples |
| SN74ACT245RKSR | ACTIVE | VQFN | RKS | 20 | 3000 | RoHS & Green | NIPDAU | Level-1-260C-UNLIM | -40 to 85 | ACT245 | Samples |

| Orderable Device | Status (1) | Package Type | Package Drawing | Pins | Package Qty | Eco Plan (2) | Lead finish/ Ball material (6) | MSL Peak Temp (3) | Op Temp (°C) | Device Marking (4/5) | Samples |
|------------------|---------------|--------------|-----------------|------|-------------|------------------|--------------------------------------|----------------------|--------------|--------------------------------------|-------------------------|
| SNJ54ACT245FK | ACTIVE | LCCC | FK | 20 | 55 | Non-RoHS & Green | SNPB | N / A for Pkg Type | -55 to 125 | 5962-8766301M2A SNJ54 ACT245FK | Samples |
| SNJ54ACT245J | ACTIVE | CDIP | J | 20 | 20 | Non-RoHS & Green | SNPB | N / A for Pkg Type | -55 to 125 | 5962-8766301MR A SNJ54ACT245J | Samples |
| SNJ54ACT245W | ACTIVE | CFP | W | 20 | 25 | Non-RoHS & Green | SNPB | N / A for Pkg Type | -55 to 125 | 5962-8766301MS A SNJ54ACT245W | Samples |

(1) The marketing status values are defined as follows:

ACTIVE: Product device recommended for new designs.

LIFEBUY: TI has announced that the device will be discontinued, and a lifetime-buy period is in effect.

NRND: Not recommended for new designs. Device is in production to support existing customers, but TI does not recommend using this part in a new design.

PREVIEW: Device has been announced but is not in production. Samples may or may not be available.

OBSELETE: TI has discontinued the production of the device.

(2) **RoHS:** TI defines "RoHS" to mean semiconductor products that are compliant with the current EU RoHS requirements for all 10 RoHS substances, including the requirement that RoHS substance do not exceed 0.1% by weight in homogeneous materials. Where designed to be soldered at high temperatures, "RoHS" products are suitable for use in specified lead-free processes. TI may reference these types of products as "Pb-Free".

RoHS Exempt: TI defines "RoHS Exempt" to mean products that contain lead but are compliant with EU RoHS pursuant to a specific EU RoHS exemption.

Green: TI defines "Green" to mean the content of Chlorine (Cl) and Bromine (Br) based flame retardants meet JS709B low halogen requirements of <=1000ppm threshold. Antimony trioxide based flame retardants must also meet the <=1000ppm threshold requirement.

(3) MSL, Peak Temp. - The Moisture Sensitivity Level rating according to the JEDEC industry standard classifications, and peak solder temperature.

(4) There may be additional marking, which relates to the logo, the lot trace code information, or the environmental category on the device.

(5) Multiple Device Markings will be inside parentheses. Only one Device Marking contained in parentheses and separated by a "~" will appear on a device. If a line is indented then it is a continuation of the previous line and the two combined represent the entire Device Marking for that device.

(6) Lead finish/Ball material - Orderable Devices may have multiple material finish options. Finish options are separated by a vertical ruled line. Lead finish/Ball material values may wrap to two lines if the finish value exceeds the maximum column width.

Important Information and Disclaimer: The information provided on this page represents TI's knowledge and belief as of the date that it is provided. TI bases its knowledge and belief on information provided by third parties, and makes no representation or warranty as to the accuracy of such information. Efforts are underway to better integrate information from third parties. TI has taken and

continues to take reasonable steps to provide representative and accurate information but may not have conducted destructive testing or chemical analysis on incoming materials and chemicals. TI and TI suppliers consider certain information to be proprietary, and thus CAS numbers and other limited information may not be available for release.

In no event shall TI's liability arising out of such information exceed the total purchase price of the TI part(s) at issue in this document sold by TI to Customer on an annual basis.

OTHER QUALIFIED VERSIONS OF SN54ACT245, SN74ACT245 :

- Catalog : [SN74ACT245](#)
- Automotive : [SN74ACT245-Q1](#), [SN74ACT245-Q1](#)
- Military : [SN54ACT245](#)
- Space : [SN54ACT245-SP](#)

NOTE: Qualified Version Definitions:

- Catalog - TI's standard catalog product
- Automotive - Q100 devices qualified for high-reliability automotive applications targeting zero defects
- Military - QML certified for Military and Defense Applications
- Space - Radiation tolerant, ceramic packaging and qualified for use in Space-based application

TAPE AND REEL INFORMATION

QUADRANT ASSIGNMENTS FOR PIN 1 ORIENTATION IN TAPE

*All dimensions are nominal

| Device | Package Type | Package Drawing | Pins | SPQ | Reel Diameter (mm) | Reel Width W1 (mm) | A0 (mm) | B0 (mm) | K0 (mm) | P1 (mm) | W (mm) | Pin1 Quadrant |
|----------------|--------------|-----------------|------|------|--------------------|--------------------|---------|---------|---------|---------|--------|---------------|
| SN74ACT245DBR | SSOP | DB | 20 | 2000 | 330.0 | 16.4 | 8.2 | 7.5 | 2.5 | 12.0 | 16.0 | Q1 |
| SN74ACT245DGSR | VSSOP | DGS | 20 | 5000 | 330.0 | 16.4 | 5.4 | 5.4 | 1.45 | 8.0 | 16.0 | Q1 |
| SN74ACT245DWR | SOIC | DW | 20 | 2000 | 330.0 | 24.4 | 10.9 | 13.3 | 2.7 | 12.0 | 24.0 | Q1 |
| SN74ACT245NSR | SO | NS | 20 | 2000 | 330.0 | 24.4 | 8.4 | 13.0 | 2.5 | 12.0 | 24.0 | Q1 |
| SN74ACT245PWR | TSSOP | PW | 20 | 2000 | 330.0 | 16.4 | 6.95 | 7.0 | 1.4 | 8.0 | 16.0 | Q1 |
| SN74ACT245RKSR | VQFN | RKS | 20 | 3000 | 180.0 | 12.4 | 2.8 | 4.8 | 1.2 | 4.0 | 12.0 | Q1 |

TAPE AND REEL BOX DIMENSIONS

*All dimensions are nominal

| Device | Package Type | Package Drawing | Pins | SPQ | Length (mm) | Width (mm) | Height (mm) |
|----------------|--------------|-----------------|------|------|-------------|------------|-------------|
| SN74ACT245DBR | SSOP | DB | 20 | 2000 | 356.0 | 356.0 | 35.0 |
| SN74ACT245DGSR | VSSOP | DGS | 20 | 5000 | 353.0 | 353.0 | 32.0 |
| SN74ACT245DWR | SOIC | DW | 20 | 2000 | 367.0 | 367.0 | 45.0 |
| SN74ACT245NSR | SO | NS | 20 | 2000 | 367.0 | 367.0 | 45.0 |
| SN74ACT245PWR | TSSOP | PW | 20 | 2000 | 356.0 | 356.0 | 35.0 |
| SN74ACT245RKS | VQFN | RKS | 20 | 3000 | 210.0 | 185.0 | 35.0 |

TUBE

*All dimensions are nominal

| Device | Package Name | Package Type | Pins | SPQ | L (mm) | W (mm) | T (μm) | B (mm) |
|-----------------|--------------|--------------|------|-----|--------|--------|--------|--------|
| 5962-8766301M2A | FK | LCCC | 20 | 55 | 506.98 | 12.06 | 2030 | NA |
| 5962-8766301MSA | W | CFP | 20 | 25 | 506.98 | 26.16 | 6220 | NA |
| SN74ACT245N | N | PDIP | 20 | 20 | 506 | 13.97 | 11230 | 4.32 |
| SN74ACT245NE4 | N | PDIP | 20 | 20 | 506 | 13.97 | 11230 | 4.32 |
| SNJ54ACT245FK | FK | LCCC | 20 | 55 | 506.98 | 12.06 | 2030 | NA |
| SNJ54ACT245W | W | CFP | 20 | 25 | 506.98 | 26.16 | 6220 | NA |

DB0020A



PACKAGE OUTLINE

SSOP - 2 mm max height

SMALL OUTLINE PACKAGE



4214851/B 08/2019

NOTES:

1. All linear dimensions are in millimeters. Any dimensions in parenthesis are for reference only. Dimensioning and tolerancing per ASME Y14.5M.
2. This drawing is subject to change without notice.
3. This dimension does not include mold flash, protrusions, or gate burrs. Mold flash, protrusions, or gate burrs shall not exceed 0.15 mm per side.
4. This dimension does not include interlead flash. Interlead flash shall not exceed 0.25 mm per side.
5. Reference JEDEC registration MO-150.

EXAMPLE BOARD LAYOUT

DB0020A

SSOP - 2 mm max height

SMALL OUTLINE PACKAGE



LAND PATTERN EXAMPLE
EXPOSED METAL SHOWN
SCALE: 10X



4214851/B 08/2019

NOTES: (continued)

- 6. Publication IPC-7351 may have alternate designs.
- 7. Solder mask tolerances between and around signal pads can vary based on board fabrication site.

EXAMPLE STENCIL DESIGN

DB0020A

SSOP - 2 mm max height

SMALL OUTLINE PACKAGE



SOLDER PASTE EXAMPLE
BASED ON 0.125 mm THICK STENCIL
SCALE: 10X

4214851/B 08/2019

NOTES: (continued)

8. Laser cutting apertures with trapezoidal walls and rounded corners may offer better paste release. IPC-7525 may have alternate design recommendations.
9. Board assembly site may have different recommendations for stencil design.

GENERIC PACKAGE VIEW

RKS 20

VQFN - 1 mm max height

2.5 x 4.5, 0.5 mm pitch

PLASTIC QUAD FLATPACK - NO LEAD

This image is a representation of the package family, actual package may vary.
Refer to the product data sheet for package details.

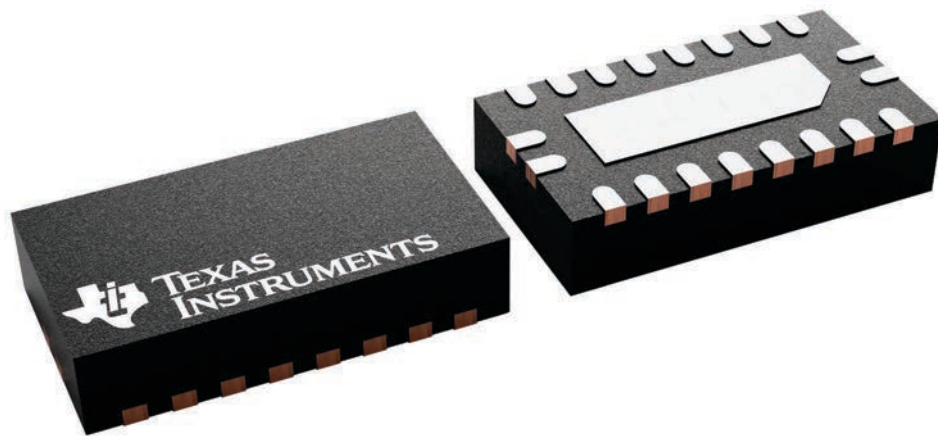

4226872/A

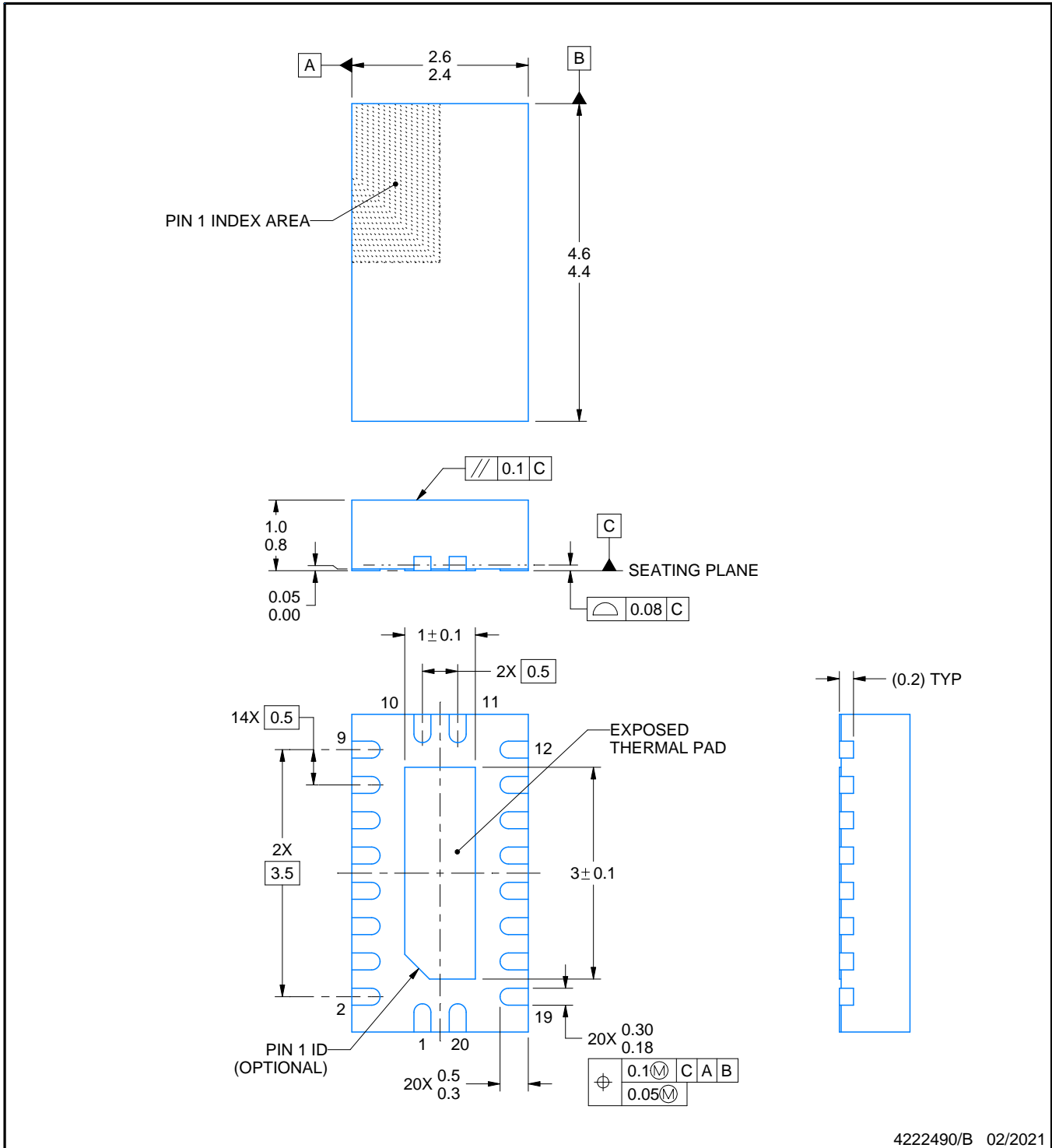

NOTES:

1. All linear dimensions are in millimeters. Any dimensions in parenthesis are for reference only. Dimensioning and tolerancing per ASME Y14.5M.
2. This drawing is subject to change without notice.
3. The package thermal pad must be soldered to the printed circuit board for thermal and mechanical performance.

EXAMPLE BOARD LAYOUT

RKS0020A

VQFN - 1 mm max height

PLASTIC QUAD FLATPACK - NO LEAD

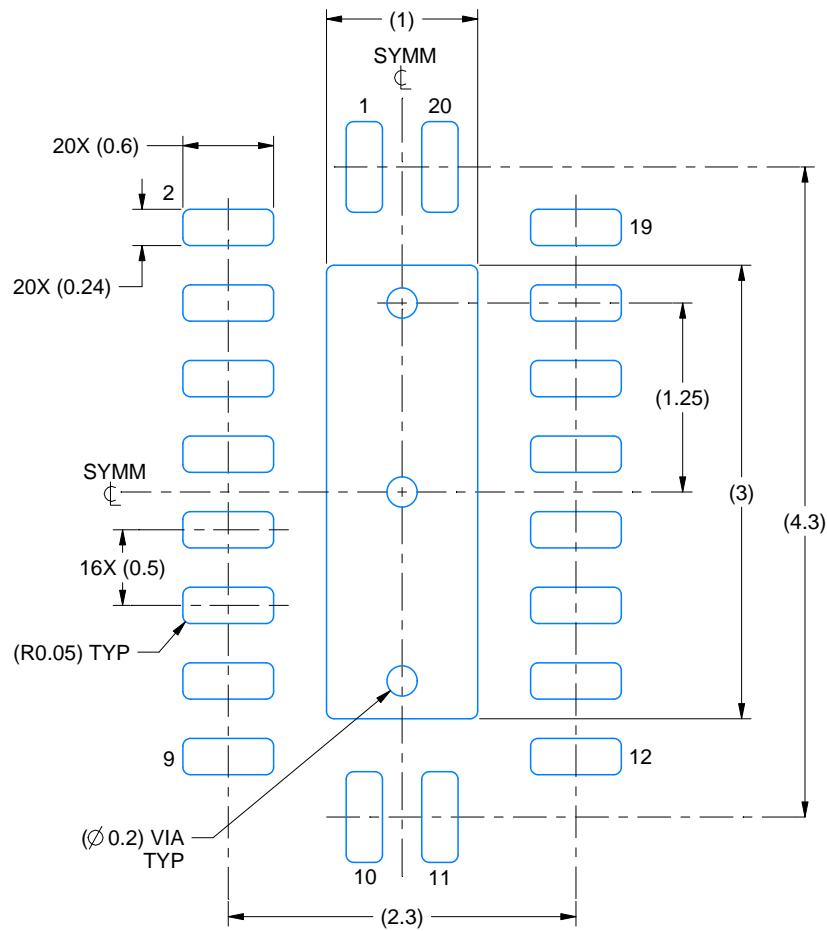

LAND PATTERN EXAMPLE
SCALE:20X

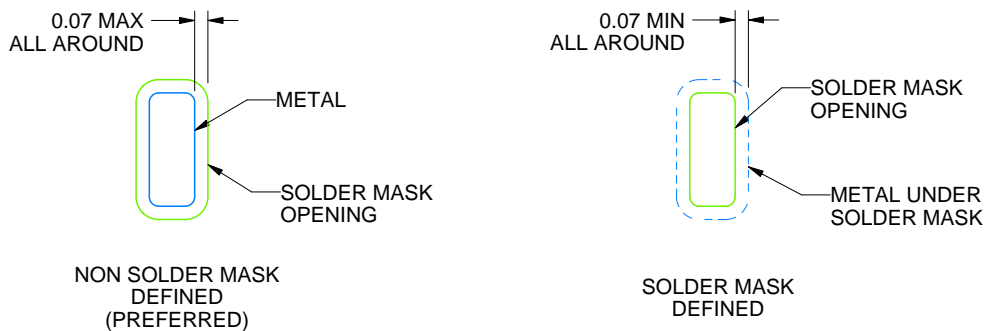

SOLDER MASK DETAILS

4222490/B 02/2021

NOTES: (continued)

- This package is designed to be soldered to a thermal pad on the board. For more information, see Texas Instruments literature number SLUA271 (www.ti.com/lit/slua271).
- Vias are optional depending on application, refer to device data sheet. If some or all are implemented, recommended via locations are shown.

EXAMPLE STENCIL DESIGN

RKS0020A

VQFN - 1 mm max height

PLASTIC QUAD FLATPACK - NO LEAD

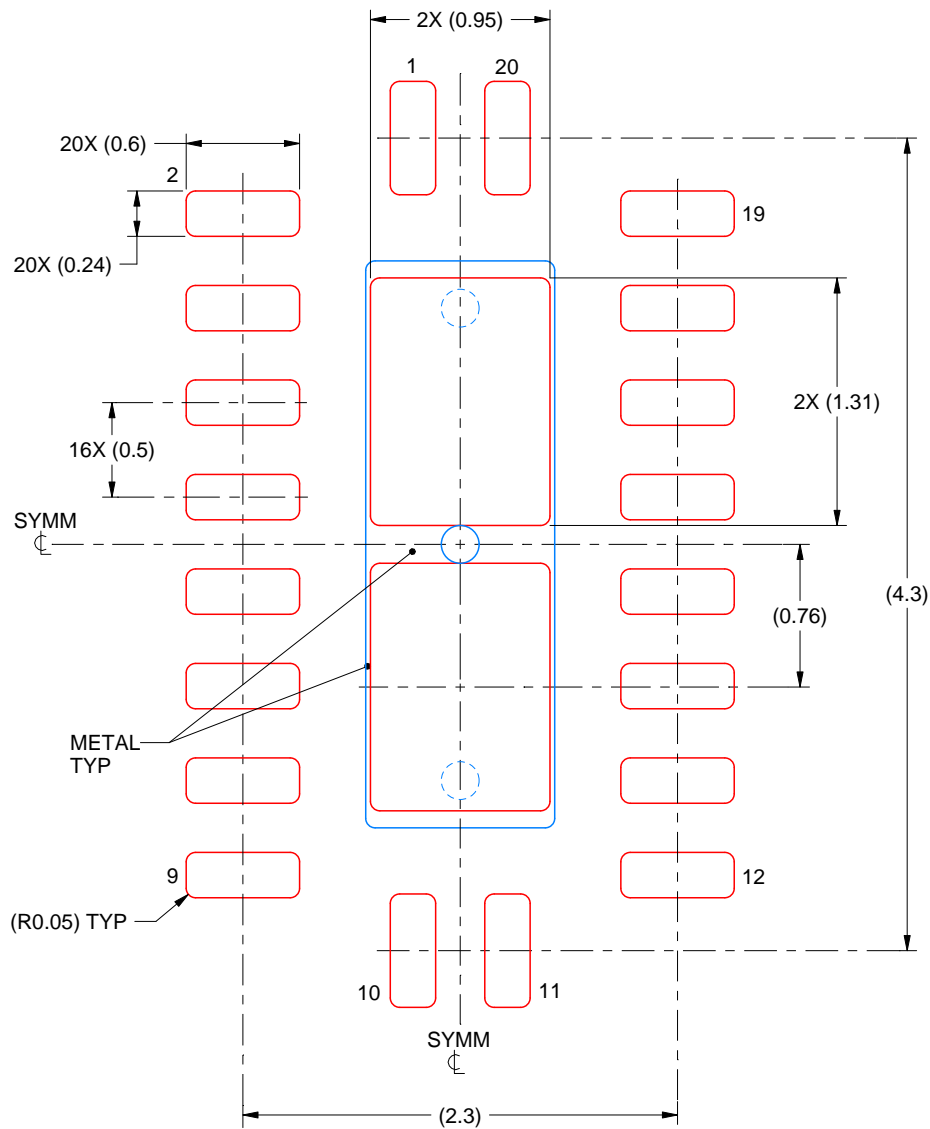

SOLDER PASTE EXAMPLE
 BASED ON 0.125 mm THICK STENCIL

EXPOSED PAD
 83% PRINTED SOLDER COVERAGE BY AREA
 SCALE:25X

4222490/B 02/2021

NOTES: (continued)

6. Laser cutting apertures with trapezoidal walls and rounded corners may offer better paste release. IPC-7525 may have alternate design recommendations.

MECHANICAL DATA

NS (R-PDSO-G**)

PLASTIC SMALL-OUTLINE PACKAGE

14-PINS SHOWN



- NOTES:
- A. All linear dimensions are in millimeters.
 - B. This drawing is subject to change without notice.
 - C. Body dimensions do not include mold flash or protrusion, not to exceed 0,15.

J (R-GDIP-T**)

14 LEADS SHOWN

CERAMIC DUAL IN-LINE PACKAGE

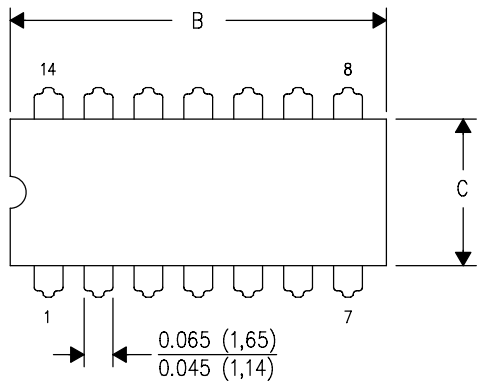

| DIM \ PINS ** | 14 | 16 | 18 | 20 |
|---------------|------------------------|------------------------|------------------------|------------------------|
| A | 0.300 (7,62) BSC | 0.300 (7,62) BSC | 0.300 (7,62) BSC | 0.300 (7,62) BSC |
| B MAX | 0.785 (19,94) | .840 (21,34) | 0.960 (24,38) | 1.060 (26,92) |
| B MIN | — | — | — | — |
| C MAX | 0.300 (7,62) | 0.300 (7,62) | 0.310 (7,87) | 0.300 (7,62) |
| C MIN | 0.245 (6,22) | 0.245 (6,22) | 0.220 (5,59) | 0.245 (6,22) |



4040083/F 03/03

- NOTES:
- All linear dimensions are in inches (millimeters).
 - This drawing is subject to change without notice.
 - This package is hermetically sealed with a ceramic lid using glass frit.
 - Index point is provided on cap for terminal identification only on press ceramic glass frit seal only.
 - Falls within MIL STD 1835 GDIP1-T14, GDIP1-T16, GDIP1-T18 and GDIP1-T20.

GENERIC PACKAGE VIEW

FK 20

LCCC - 2.03 mm max height

8.89 x 8.89, 1.27 mm pitch

LEADLESS CERAMIC CHIP CARRIER

This image is a representation of the package family, actual package may vary.
Refer to the product data sheet for package details.





4229370VA\

N (R-PDIP-T**)

PLASTIC DUAL-IN-LINE PACKAGE

16 PINS SHOWN



- NOTES:
- A. All linear dimensions are in inches (millimeters).
 - B. This drawing is subject to change without notice.
 -  Falls within JEDEC MS-001, except 18 and 20 pin minimum body length (Dim A).
 -  The 20 pin end lead shoulder width is a vendor option, either half or full width.

DW0020A



PACKAGE OUTLINE

SOIC - 2.65 mm max height

SOIC



4220724/A 05/2016

EXAMPLE BOARD LAYOUT

DW0020A

SOIC - 2.65 mm max height

SOIC



LAND PATTERN EXAMPLE
SCALE:6X



SOLDER MASK DETAILS

4220724/A 05/2016

NOTES: (continued)

- 6. Publication IPC-7351 may have alternate designs.
- 7. Solder mask tolerances between and around signal pads can vary based on board fabrication site.

EXAMPLE STENCIL DESIGN

DW0020A

SOIC - 2.65 mm max height

SOIC



SOLDER PASTE EXAMPLE
BASED ON 0.125 mm THICK STENCIL
SCALE:6X

4220724/A 05/2016

NOTES: (continued)

8. Laser cutting apertures with trapezoidal walls and rounded corners may offer better paste release. IPC-7525 may have alternate design recommendations.
9. Board assembly site may have different recommendations for stencil design.

W (R-GDFP-F20)

CERAMIC DUAL FLATPACK

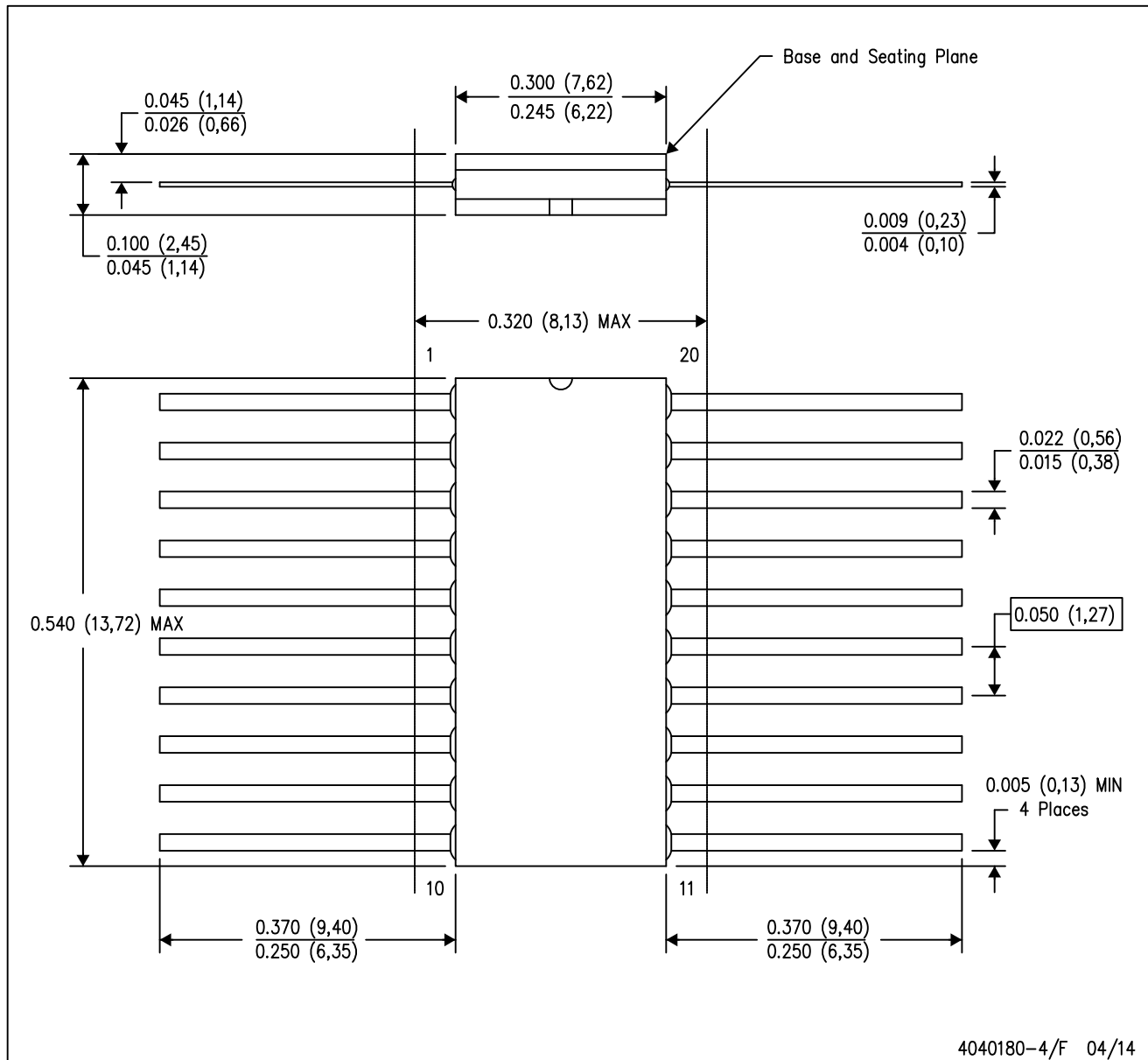

- NOTES:
- A. All linear dimensions are in inches (millimeters).
 - B. This drawing is subject to change without notice.
 - C. This package can be hermetically sealed with a ceramic lid using glass frit.
 - D. Index point is provided on cap for terminal identification only.
 - E. Falls within Mil-Std 1835 GDFP2-F20

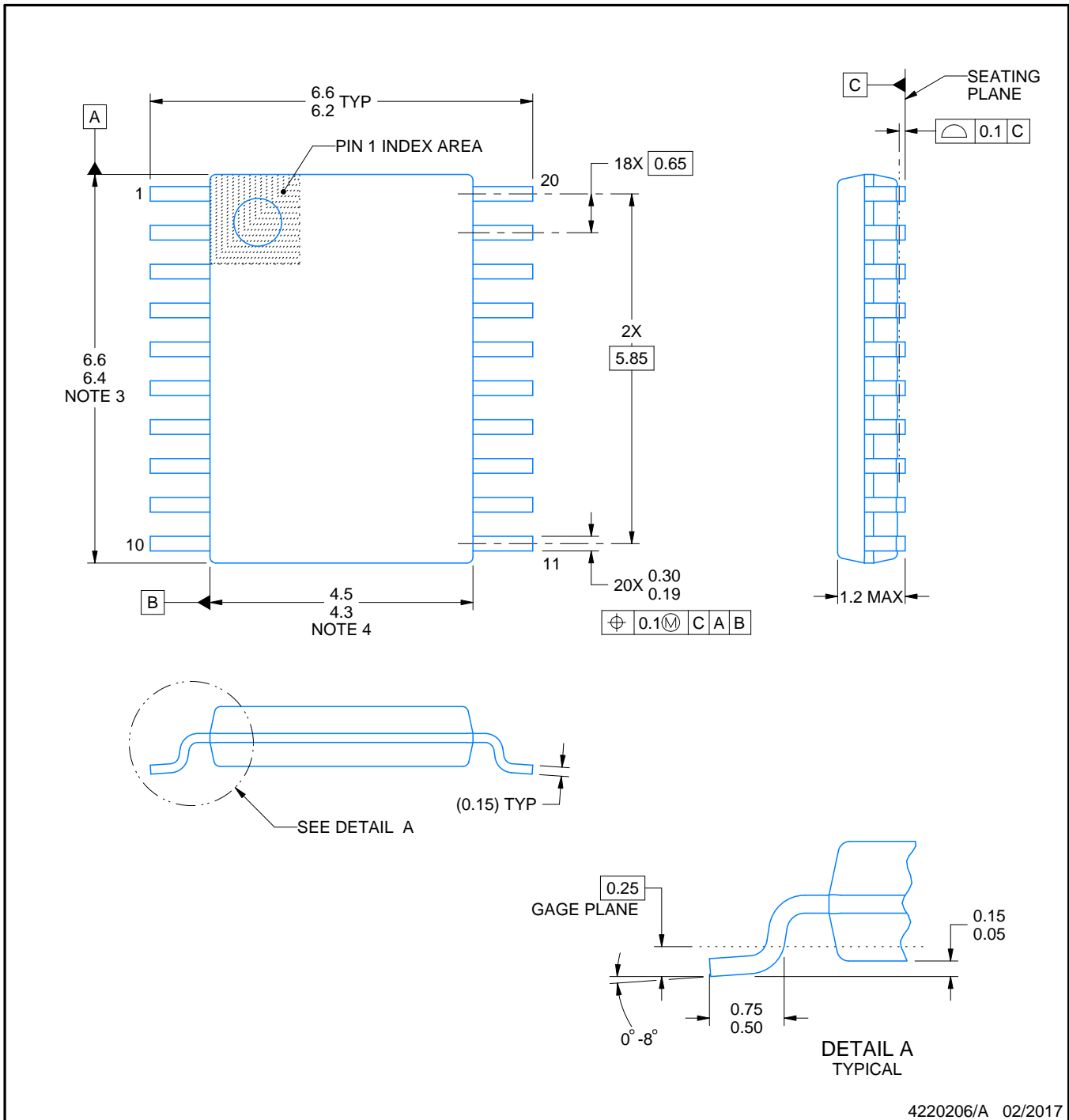
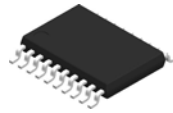

4220206/A 02/2017

NOTES:

1. All linear dimensions are in millimeters. Any dimensions in parenthesis are for reference only. Dimensioning and tolerancing per ASME Y14.5M.
2. This drawing is subject to change without notice.
3. This dimension does not include mold flash, protrusions, or gate burrs. Mold flash, protrusions, or gate burrs shall not exceed 0.15 mm per side.
4. This dimension does not include interlead flash. Interlead flash shall not exceed 0.25 mm per side.
5. Reference JEDEC registration MO-153.

EXAMPLE BOARD LAYOUT

PW0020A

TSSOP - 1.2 mm max height

SMALL OUTLINE PACKAGE

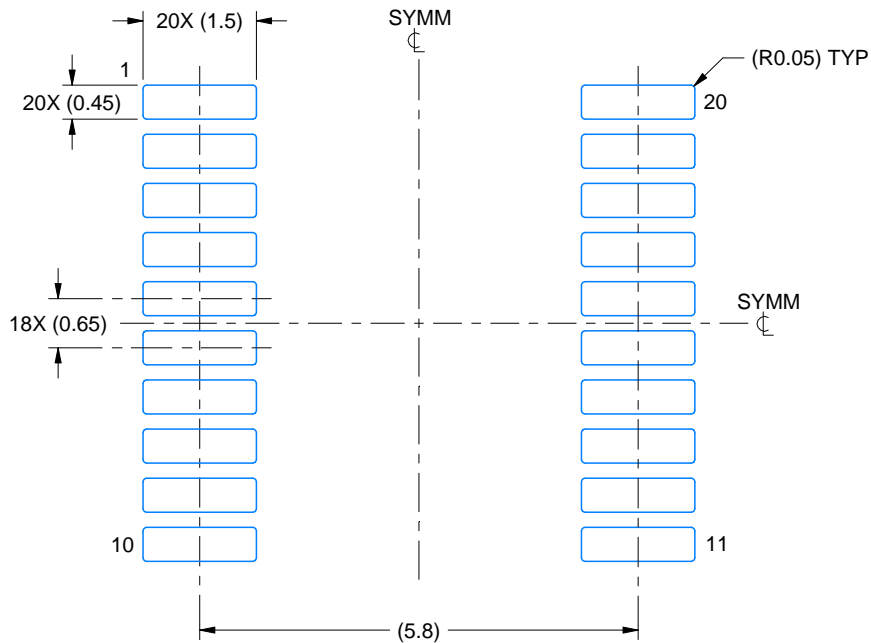

LAND PATTERN EXAMPLE
EXPOSED METAL SHOWN
SCALE: 10X



SOLDER MASK DETAILS

4220206/A 02/2017

NOTES: (continued)

- 6. Publication IPC-7351 may have alternate designs.
- 7. Solder mask tolerances between and around signal pads can vary based on board fabrication site.

EXAMPLE STENCIL DESIGN

PW0020A

TSSOP - 1.2 mm max height

SMALL OUTLINE PACKAGE

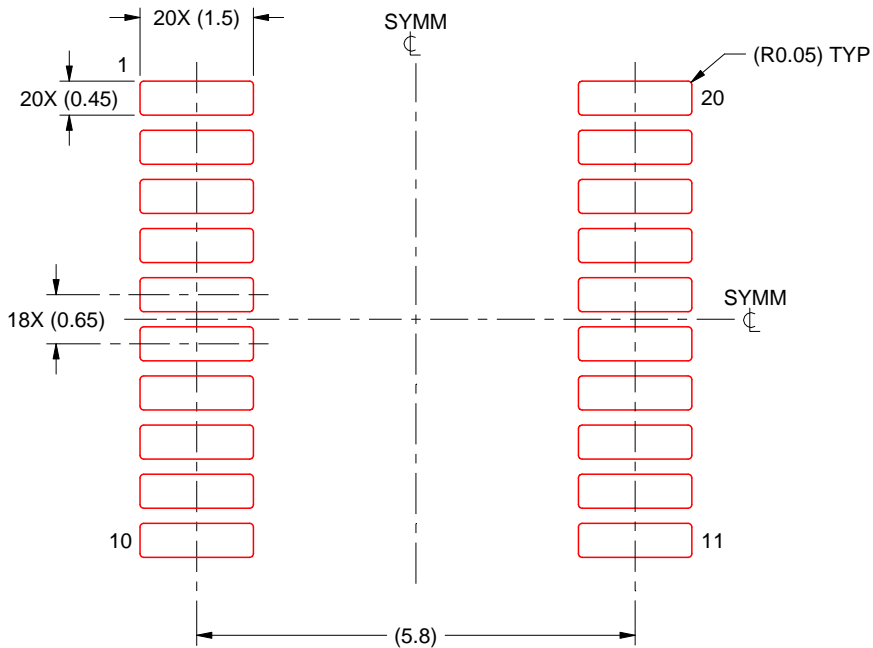

SOLDER PASTE EXAMPLE
BASED ON 0.125 mm THICK STENCIL
SCALE: 10X

4220206/A 02/2017

NOTES: (continued)

8. Laser cutting apertures with trapezoidal walls and rounded corners may offer better paste release. IPC-7525 may have alternate design recommendations.
9. Board assembly site may have different recommendations for stencil design.

IMPORTANT NOTICE AND DISCLAIMER

TI PROVIDES TECHNICAL AND RELIABILITY DATA (INCLUDING DATA SHEETS), DESIGN RESOURCES (INCLUDING REFERENCE DESIGNS), APPLICATION OR OTHER DESIGN ADVICE, WEB TOOLS, SAFETY INFORMATION, AND OTHER RESOURCES "AS IS" AND WITH ALL FAULTS, AND DISCLAIMS ALL WARRANTIES, EXPRESS AND IMPLIED, INCLUDING WITHOUT LIMITATION ANY IMPLIED WARRANTIES OF MERCHANTABILITY, FITNESS FOR A PARTICULAR PURPOSE OR NON-INFRINGEMENT OF THIRD PARTY INTELLECTUAL PROPERTY RIGHTS.

These resources are intended for skilled developers designing with TI products. You are solely responsible for (1) selecting the appropriate TI products for your application, (2) designing, validating and testing your application, and (3) ensuring your application meets applicable standards, and any other safety, security, regulatory or other requirements.

These resources are subject to change without notice. TI grants you permission to use these resources only for development of an application that uses the TI products described in the resource. Other reproduction and display of these resources is prohibited. No license is granted to any other TI intellectual property right or to any third party intellectual property right. TI disclaims responsibility for, and you will fully indemnify TI and its representatives against, any claims, damages, costs, losses, and liabilities arising out of your use of these resources.

TI's products are provided subject to [TI's Terms of Sale](#) or other applicable terms available either on [ti.com](https://www.ti.com) or provided in conjunction with such TI products. TI's provision of these resources does not expand or otherwise alter TI's applicable warranties or warranty disclaimers for TI products.

TI objects to and rejects any additional or different terms you may have proposed.

Mailing Address: Texas Instruments, Post Office Box 655303, Dallas, Texas 75265
Copyright © 2024, Texas Instruments Incorporated

Looking for pricing, stock, or lifecycle information?

Click below to explore more details on WIN SOURCE:

 [View SN74ACT245PWR on WIN SOURCE](#)

 [Texas Instruments](#) Information

Optimize Your Supply Chain with WIN SOURCE Solutions

-  Global Sourcing Solution
-  Obsolete Management
-  Cost Control Management
-  Shortage Management
-  Alternative Solution
-  Excess Inventory Management