



**THE DATASHEET OF  
SN74AHC138PWR**



## SNx4AHC138 3-Line to 8-Line Decoders/Demultiplexers

### 1 Features

- Operating range 2V to 5.5V  $V_{CC}$
- Designed specifically for high-speed memory decoders and data-transmission systems
- Incorporate three enable inputs to simplify cascading and/or data reception
- Latch-up performance exceeds 250mA per JESD 17
- ESD protection exceeds JESD 22:
  - 2000V Human-Body Model (A114-A)
  - 1000V Charged-Device Model (C101)

### 2 Description

The SNx4AHC138 decoders/demultiplexers are designed for high-performance memory-decoding and data-routing applications that require very short propagation-delay times. In high-performance memory systems, these decoders can be used to minimize the effects of system decoding. When employed with high-speed memories utilizing a fast enable circuit, the delay times of these decoders and the enable time of the memory usually are less than the typical access time of the memory. This means that the effective system delay introduced by the decoders is negligible.

#### Device Information

PART NUMBER	PACKAGE <sup>(1)</sup>	PACKAGE SIZE <sup>(2)</sup>	BODY SIZE <sup>(3)</sup>
SN74AHC138	RGY (VQFN, 16)	4mm x 3.5mm	4mm x 3.5mm
	N (PDIP, 16)	19.3 mm x 9.4 mm	19.32 mm x 6.35 mm
	D (SOIC, 16)	9.9 mm x 6 mm	9.90 mm x 3.90 mm
	NS (SOP, 16)	10.2mm x 7.8mm	10.20 mm x 5.30 mm
	DB (SSOP, 16)	6.2 mm x 7.8 mm	6.20 mm x 5.30 mm
	PW (TSSOP, 16)	5 mm x 6.4 mm	5.00 mm x 4.40 mm
	DGV (TVSOP, 16)	3.6mm x 6.4mm	3.6mm x 4.4mm

- (1) For more information, see [Section 10](#).
- (2) The package size (length x width) is a nominal value and includes pins, where applicable.
- (3) The body size (length x width) is a nominal value and does not include pins.

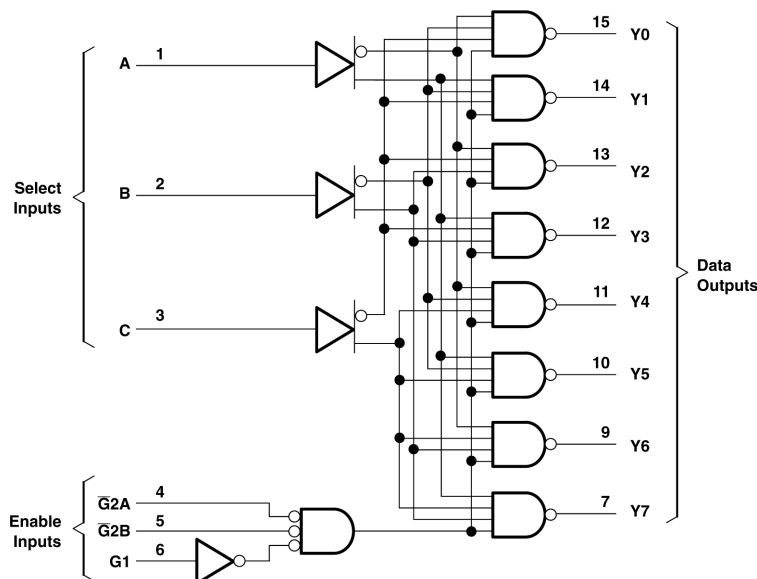

Logic Diagram (Positive Logic)



## Table of Contents

<b>1 Features</b> .....	1	6.3 Function Table.....	9
<b>2 Description</b> .....	1	<b>7 Application and Implementation</b> .....	10
<b>3 Pin Configuration and Functions</b> .....	3	7.1 Application Information.....	10
<b>4 Specifications</b> .....	5	7.2 Power Supply Recommendations.....	11
4.1 Absolute Maximum Ratings.....	5	7.3 Layout.....	12
4.2 Recommended Operating Conditions.....	5	<b>8 Device and Documentation Support</b> .....	13
4.3 Thermal Information.....	6	8.1 Documentation Support (Analog).....	13
4.4 Electrical Characteristics.....	6	8.2 Receiving Notification of Documentation Updates... 13	
4.5 Switching Characteristics: $V_{CC} = 3.3V \pm 0.3V$ .....	6	8.3 Support Resources.....	13
4.6 Switching Characteristics: $V_{CC} = 5V \pm 0.5V$ .....	7	8.4 Trademarks.....	13
4.7 Operating Characteristics.....	7	8.5 Electrostatic Discharge Caution.....	13
<b>5 Parameter Measurement Information</b> .....	8	8.6 Glossary.....	13
<b>6 Detailed Description</b> .....	9	<b>9 Revision History</b> .....	13
6.1 Overview.....	9	<b>10 Mechanical, Packaging, and Orderable Information</b> .....	14
6.2 Functional Block Diagram.....	9		

### 3 Pin Configuration and Functions

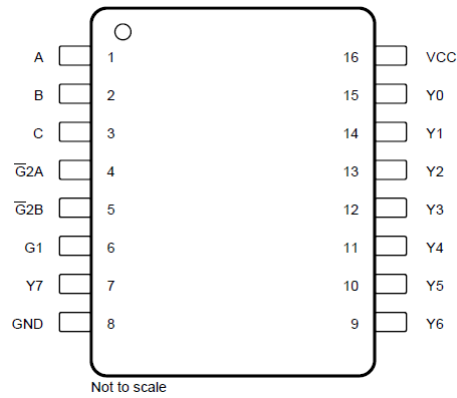

Figure 3-1. D, DB, DGV , N, NS , or PW Package, 16-Pin SOIC, SSOP, TVSOP, PDIP, SOP, or TSSOP (Top View)

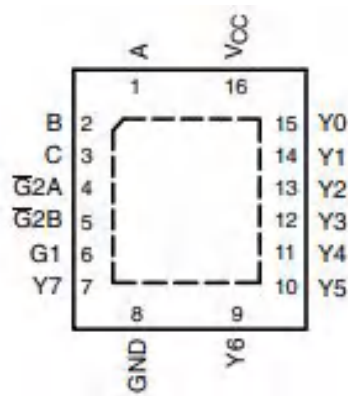
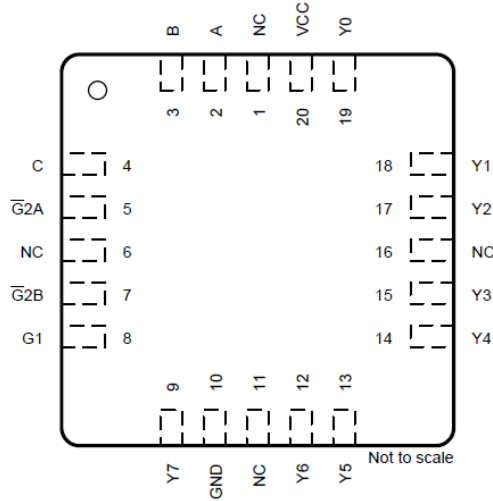

Figure 3-2. RGY Package, 16-Pin VQFN (Top View)



NC: No internal connection

**FK Package,  
20-Pin LCCC  
(Top View)**

**Table 3-1. Pin Functions**

PIN		TYPE <sup>(1)</sup>	DESCRIPTION
NAME	NO.		
A <sub>0</sub>	1	I	Address select 0
A <sub>1</sub>	2	I	Address select 1
A <sub>2</sub>	3	I	Address select 2
$\overline{G}_0$	4	I	Output strobe 0, active low
$\overline{G}_1$	5	I	Output strobe 1, active low
G <sub>2</sub>	6	I	Output strobe 2
Y <sub>7</sub>	7	O	Output 7
GND	8	G	Ground
Y <sub>6</sub>	9	O	Output 6
Y <sub>5</sub>	10	O	Output 5
Y <sub>4</sub>	11	O	Output 4
Y <sub>3</sub>	12	O	Output 3
Y <sub>2</sub>	13	O	Output 2
Y <sub>1</sub>	14	O	Output 1
Y <sub>0</sub>	15	O	Output 0
V <sub>CC</sub>	16	P	Positive supply
Thermal pad <sup>(2)</sup>			The thermal pad can be connected to GND or left floating. Do not connect to any other signal or supply.

(1) Signal Types: I = Input, O = Output, I/O = Input or Output, P = Power, G = Ground.

(2) WBQB package only.

## 4 Specifications

### 4.1 Absolute Maximum Ratings

over operating free-air temperature range (unless otherwise noted)<sup>(1)</sup>

		MIN	MAX	UNIT
$V_{CC}$	Supply voltage range	-0.5	7	V
$V_I$ <sup>(2)</sup>	Input voltage range	-0.5	7	V
$V_O$ <sup>(2)</sup>	Output voltage range	-0.5	$V_{CC} + 0.5$	V
$I_{IK}$	Input clamp current	$(V_I < 0)$		-20 mA
$I_{OK}$	Output clamp current	$(V_O < 0 \text{ or } V_O > V_{CC})$		±20 mA
$I_O$	Continuous output current	$(V_O = 0 \text{ to } V_{CC})$		±25 mA
	Continuous current through $V_{CC}$ or GND			±75 mA
$T_{stg}$	Storage temperature range	-65	150	°C

- (1) Stresses beyond those listed under “absolute maximum ratings” may cause permanent damage to the device. These are stress ratings only, and functional operation of the device at these or any other conditions beyond those indicated under “recommended operating conditions” is not implied. Exposure to absolute-maximum-rated conditions for extended periods may affect device reliability.
- (2) The input and output voltage ratings may be exceeded if the input and output current ratings are observed.

### 4.2 Recommended Operating Conditions

over operating free-air temperature range (unless otherwise noted)<sup>(1)</sup>

		SN54AHC138		SN74AHC138		UNIT
		MIN	MAX	MIN	MAX	
$V_{CC}$	Supply voltage	2	5.5	2	5.5	V
$V_{IH}$	High-level input voltage	$V_{CC} = 2 \text{ V}$		1.5		V
		$V_{CC} = 3 \text{ V}$		2.1		
		$V_{CC} = 5.5 \text{ V}$		3.85		
$V_{IL}$	Low-level input voltage	$V_{CC} = 2 \text{ V}$		0.5		V
		$V_{CC} = 3 \text{ V}$		0.9		
		$V_{CC} = 5.5 \text{ V}$		1.65		
$V_I$	Input voltage	0 5.5		0 5.5		V
$V_O$	Output voltage	0	$V_{CC}$	0	$V_{CC}$	V
$I_{OH}$	High-level output current	$V_{CC} = 2 \text{ V}$		-50		-50 mA
		$V_{CC} = 3.3 \text{ V} \pm 0.3 \text{ V}$		-4		-4 mA
		$V_{CC} = 5 \text{ V} \pm 0.5 \text{ V}$		-8		-8 mA
$I_{OL}$	Low-level output current	$V_{CC} = 2 \text{ V}$		50		50 mA
		$V_{CC} = 3.3 \text{ V} \pm 0.3 \text{ V}$		4		4 mA
		$V_{CC} = 5 \text{ V} \pm 0.5 \text{ V}$		8		8 mA
$\Delta t/\Delta v$	Input transition rise or fall rate	$V_{CC} = 3.3 \text{ V} \pm 0.3 \text{ V}$		100		ns/V
		$V_{CC} = 5 \text{ V} \pm 0.5 \text{ V}$		20		
$T_A$	Operating free-air temperature	-55	125	-40	85	°C

- (1) All unused inputs of the device must be held at  $V_{CC}$  or GND to ensure proper device operation. Refer to the TI application report, *Implications of Slow or Floating CMOS Inputs*, literature number SCBA004.

### 4.3 Thermal Information

THERMAL METRIC <sup>(1)</sup>		SN74AHC138							UNIT
		D	DB	DGV	N	NS	PW	RGY	
		16							
R <sub>θJA</sub>	Junction-to-ambient thermal resistance	73 (SOIC)	82 (SSOP)	120 (TVSOP)	67 (PDIP)	64 (SOP)	135.9 (TSSOP)	39 (VQFN)	°C/W

(1) For more information about traditional and new thermal metrics, see the [Semiconductor and IC package thermal metrics](#) application report.

### 4.4 Electrical Characteristics

over recommended operating free-air temperature range (unless otherwise noted)

PARAMETER	TEST CONDITIONS	V <sub>CC</sub>	T <sub>A</sub> = 25°C			SN54AHC138		SN74AHC138		UNIT
			MIN	TYP	MAX	MIN	MAX	MIN	MAX	
V <sub>OH</sub>	I <sub>OH</sub> = -50µA	2 V	1.9	2		1.9		1.9	V	
		3 V	2.9	3		2.9		2.9		
		4.5 V	4.4	4.5		4.4		4.4		
	I <sub>OH</sub> = -4 mA	3 V	2.58			2.48		2.48		
	I <sub>OH</sub> = -8 mA	4.5 V	3.94			3.8		3.8		
V <sub>OL</sub>	I <sub>OL</sub> = 50µA	2 V		0.1			0.1		0.1	V
		3 V		0.1			0.1		0.1	
		4.5 V		0.1			0.1		0.1	
	I <sub>OL</sub> = 4 mA	3 V		0.36			0.5		0.44	
	I <sub>OL</sub> = 8 mA	4.5 V		0.36			0.5		0.44	
I <sub>I</sub>	V <sub>I</sub> = 5.5 V or GND	0 V to 5.5 V		±0.1			±1 <sup>(1)</sup>		±1	µA
I <sub>CC</sub>	V <sub>I</sub> = V <sub>CC</sub> or GND, I <sub>O</sub> = 0	5.5 V		4			40		40	µA
C <sub>i</sub>	V <sub>I</sub> = V <sub>CC</sub> or GND	5 V		2	10				10	pF

(1) On products compliant to MIL-PRF-38535, this parameter is not production tested at V<sub>CC</sub> = 0 V.

### 4.5 Switching Characteristics: V<sub>CC</sub> = 3.3V ± 0.3V

over recommended operating free-air temperature range, V<sub>CC</sub> = 3.3V ± 0.3V (unless otherwise noted) (see [Load Circuit and Voltage Waveforms](#))

PARAMETER	FROM (INPUT)	TO (OUTPUT)	LOAD CAPACITANCE	T <sub>A</sub> = 25°C			SN54AHC138		SN74AHC138		UNIT
				MIN	TYP	MAX	MIN	MAX	MIN	MAX	
t <sub>PLH</sub>	A, B, C	Any Y	C <sub>L</sub> = 15pF		8.2 <sup>(1)</sup>	11.4 <sup>(1)</sup>	1 <sup>(1)</sup>	13 <sup>(1)</sup>	1	13	ns
t <sub>PHL</sub>					8.2 <sup>(1)</sup>	11.4 <sup>(1)</sup>	1 <sup>(1)</sup>	13 <sup>(1)</sup>	1	13	
t <sub>PLH</sub>	G1	Any Y	C <sub>L</sub> = 15pF		8.1 <sup>(1)</sup>	12.8 <sup>(1)</sup>	1 <sup>(1)</sup>	15 <sup>(1)</sup>	1	15	ns
t <sub>PHL</sub>					8.1 <sup>(1)</sup>	12.8 <sup>(1)</sup>	1 <sup>(1)</sup>	15 <sup>(1)</sup>	1	15	
t <sub>PLH</sub>	G̅2A, G̅2B	Any Y	C <sub>L</sub> = 15pF		8.2 <sup>(1)</sup>	11.4 <sup>(1)</sup>	1 <sup>(1)</sup>	13.5 <sup>(1)</sup>	1	13.5	ns
t <sub>PHL</sub>					8.2 <sup>(1)</sup>	11.4 <sup>(1)</sup>	1 <sup>(1)</sup>	13.5 <sup>(1)</sup>	1	13.5	
t <sub>PLH</sub>	A, B, C	Any Y	C <sub>L</sub> = 50pF		10	15.8	1	18	1	18	ns
t <sub>PHL</sub>					10	15.8	1	18	1	18	
t <sub>PLH</sub>	G1	Any Y	C <sub>L</sub> = 50pF		10.6	16.3	1	18.5	1	18.5	ns
t <sub>PHL</sub>					10.6	16.3	1	18.5	1	18.5	
t <sub>PLH</sub>	G̅2A, G̅2B	Any Y	C <sub>L</sub> = 50pF		10.7	14.9	1	17	1	17	ns
t <sub>PHL</sub>					10.7	14.9	1	17	1	17	

(1) On products compliant to MIL-PRF-38535, this parameter is not production tested.

#### 4.6 Switching Characteristics: $V_{CC} = 5V \pm 0.5V$

over recommended operating free-air temperature range,  $V_{CC} = 5V \pm 0.5V$  (unless otherwise noted) (see [Load Circuit and Voltage Waveforms](#))

PARAMETER	FROM (INPUT)	TO (OUTPUT)	LOAD CAPACITANCE	$T_A = 25^\circ\text{C}$			SN54AHC138		SN74AHC138		UNIT
				MIN	TYP	MAX	MIN	MAX	MIN	MAX	
$t_{PLH}$	A, B, C	Any Y	$C_L = 15\text{pF}$		5.7 <sup>(1)</sup>	8.1 <sup>(1)</sup>	1 <sup>(1)</sup>	9.5 <sup>(1)</sup>	1	9.5	ns
$t_{PHL}$					5.7 <sup>(1)</sup>	8.1 <sup>(1)</sup>	1 <sup>(1)</sup>	9.5 <sup>(1)</sup>	1	9.5	
$t_{PLH}$	G1	Any Y	$C_L = 15\text{pF}$		5.6 <sup>(1)</sup>	8.1 <sup>(1)</sup>	1 <sup>(1)</sup>	9.5 <sup>(1)</sup>	1	9.5	ns
$t_{PHL}$					5.6 <sup>(1)</sup>	8.1 <sup>(1)</sup>	1 <sup>(1)</sup>	9.5 <sup>(1)</sup>	1	9.5	
$t_{PLH}$	$\overline{G}2A, \overline{G}2B$	Any Y	$C_L = 15\text{pF}$		5.8 <sup>(1)</sup>	8.1 <sup>(1)</sup>	1 <sup>(1)</sup>	9.5 <sup>(1)</sup>	1	9.5	ns
$t_{PHL}$					5.8 <sup>(1)</sup>	8.1 <sup>(1)</sup>	1 <sup>(1)</sup>	9.5 <sup>(1)</sup>	1	9.5	
$t_{PLH}$	A, B, C	Any Y	$C_L = 50\text{pF}$		7.2	10.1	1	11.5	1	11.5	ns
$t_{PHL}$					7.2	10.1	1	11.5	1	11.5	
$t_{PLH}$	G1	Any Y	$C_L = 50\text{pF}$		7.1	10.1	1	11.5	1	11.5	ns
$t_{PHL}$					7.1	10.1	1	11.5	1	11.5	
$t_{PLH}$	$\overline{G}2A, \overline{G}2B$	Any Y	$C_L = 50\text{pF}$		7.3	10.1	1	11.5	1	11.5	ns
$t_{PHL}$					7.3	10.1	1	11.5	1	11.5	

(1) On products compliant to MIL-PRF-38535, this parameter is not production tested.

#### 4.7 Operating Characteristics

$V_{CC} = 5\text{V}$ ,  $T_A = 25^\circ\text{C}$

PARAMETER	TEST CONDITIONS	TYP	UNIT
$C_{pd}$ Power dissipation capacitance	No load, $f = 1\text{MHz}$	13	pF

## 5 Parameter Measurement Information

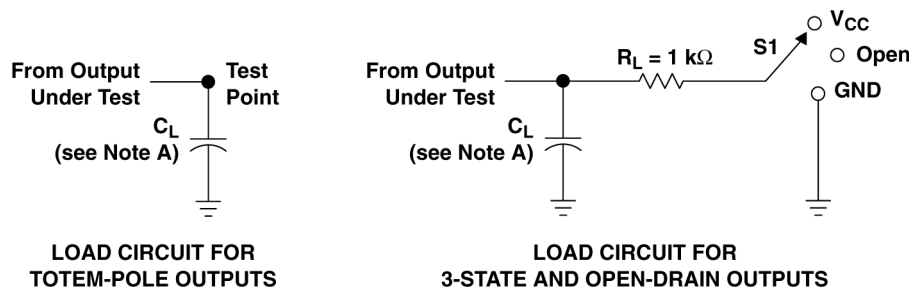

LOAD CIRCUIT FOR TOTEM-POLE OUTPUTS

LOAD CIRCUIT FOR 3-STATE AND OPEN-DRAIN OUTPUTS

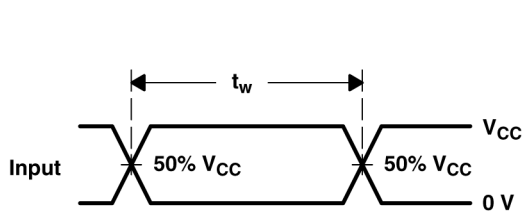

VOLTAGE WAVEFORMS PULSE DURATION

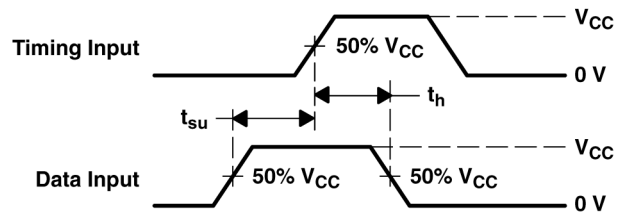

VOLTAGE WAVEFORMS SETUP AND HOLD TIMES

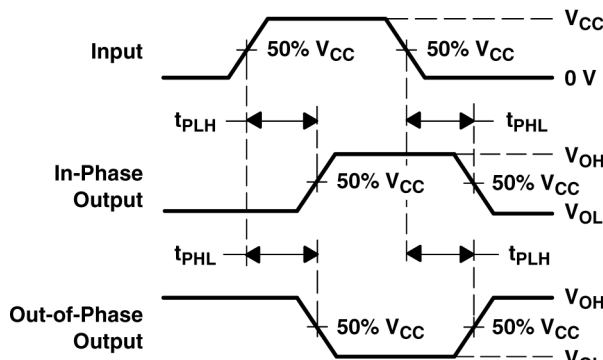

VOLTAGE WAVEFORMS PROPAGATION DELAY TIMES INVERTING AND NONINVERTING OUTPUTS

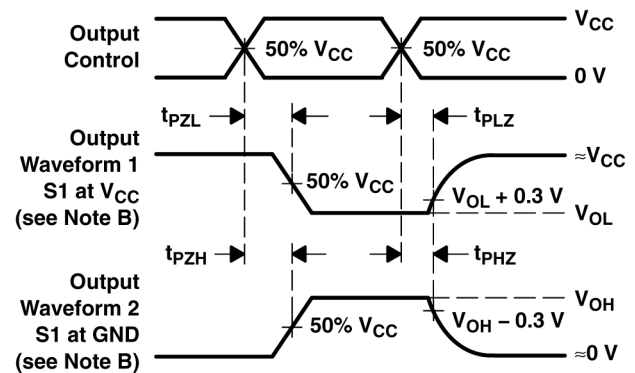

VOLTAGE WAVEFORMS ENABLE AND DISABLE TIMES LOW- AND HIGH-LEVEL ENABLING

- A.  $C_L$  includes probe and jig capacitance.
- B. Waveform 1 is for an output with internal conditions such that the output is low except when disabled by the output control. Waveform 2 is for an output with internal conditions such that the output is high except when disabled by the output control.
- C. All input pulses are supplied by generators having the following characteristics:  $PRR \leq 1$  MHz,  $Z_O = 50 \Omega$ ,  $t_r \leq 3$  ns,  $t_f \leq 3$  ns.
- D. The outputs are measured one at a time with one input transition per measurement.
- E. All parameters and waveforms are not applicable to all devices.

Figure 5-1. Load Circuit and Voltage Waveforms

TEST	S1
$t_{PLH}/t_{PHL}$	Open
$t_{PLZ}/t_{PZL}$	$V_{CC}$
$t_{PHZ}/t_{PZH}$	GND
Open Drain	$V_{CC}$

## 6 Detailed Description

### 6.1 Overview

The conditions at the binary-select inputs and the three enable inputs select one of eight output lines. Two active-low and one active-high enable inputs reduce the need for external gates or inverters when expanding. A 24-line decoder can be implemented without external inverters, and a 32-line decoder requires only one inverter. An enable input can be used as a data input for demultiplexing applications.

### 6.2 Functional Block Diagram

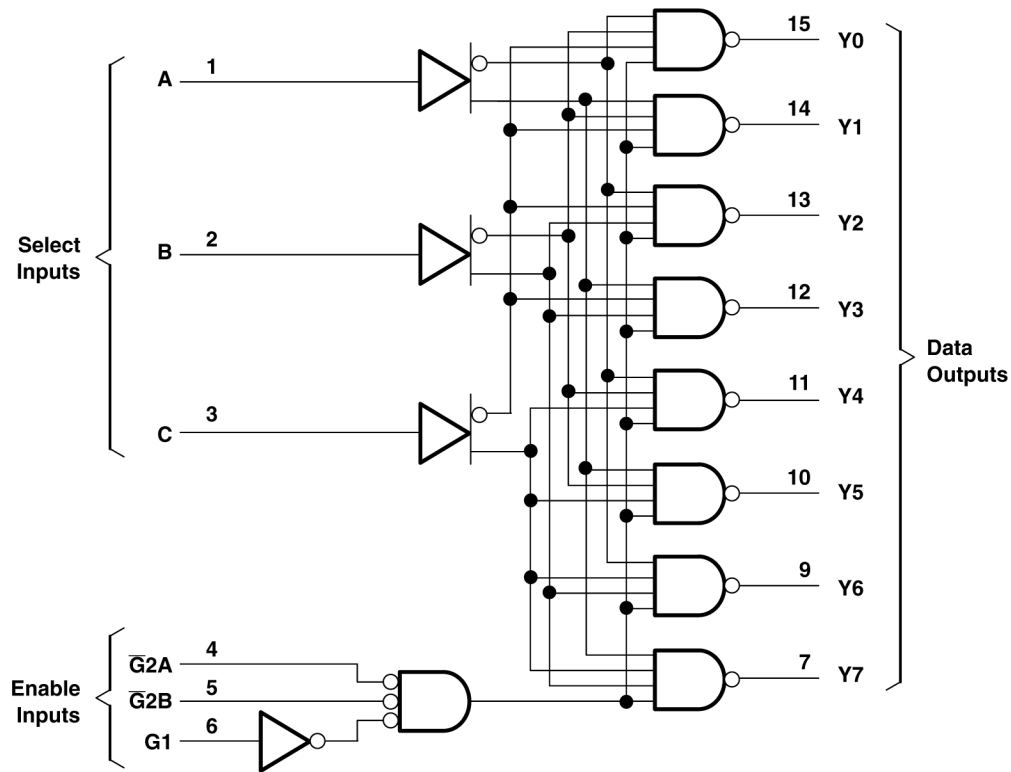

Pin numbers shown are for the D, DB, DGV, J, N, NS, PW, RGY, and W packages.

### 6.3 Function Table

ENABLE INPUTS			SELECT INPUTS			OUTPUTS							
G1	$\overline{G2A}$	$\overline{G2B}$	C	B	A	Y0	Y1	Y2	Y3	Y4	Y5	Y6	Y7
X	H	X	X	X	X	H	H	H	H	H	H	H	H
X	X	H	X	X	X	H	H	H	H	H	H	H	H
L	X	X	X	X	X	H	H	H	H	H	H	H	H
H	L	L	L	L	L	L	H	H	H	H	H	H	H
H	L	L	L	L	H	H	L	H	H	H	H	H	H
H	L	L	L	H	L	H	H	L	H	H	H	H	H
H	L	L	L	H	H	H	H	H	L	H	H	H	H
H	L	L	H	L	L	H	H	H	H	L	H	H	H
H	L	L	H	L	H	H	H	H	H	H	L	H	H
H	L	L	H	H	L	H	H	H	H	H	H	L	H
H	L	L	H	H	H	H	H	H	H	H	H	H	L

## 7 Application and Implementation

### Note

Information in the following applications sections is not part of the TI component specification, and TI does not warrant its accuracy or completeness. TI's customers are responsible for determining suitability of components for their purposes, as well as validating and testing their design implementation to confirm system functionality.

### 7.1 Application Information

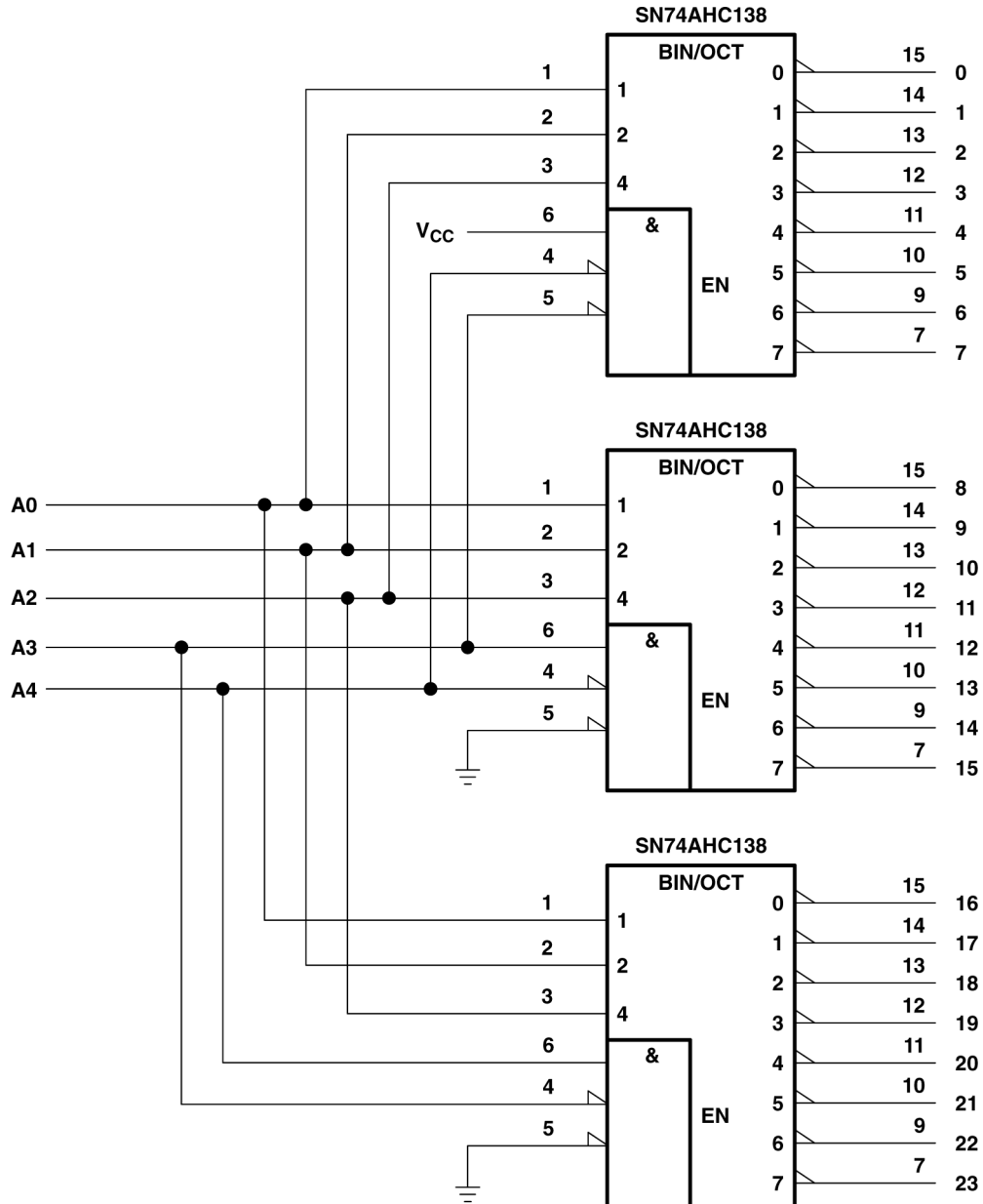

Figure 7-1. 24-Bit Decoding Scheme

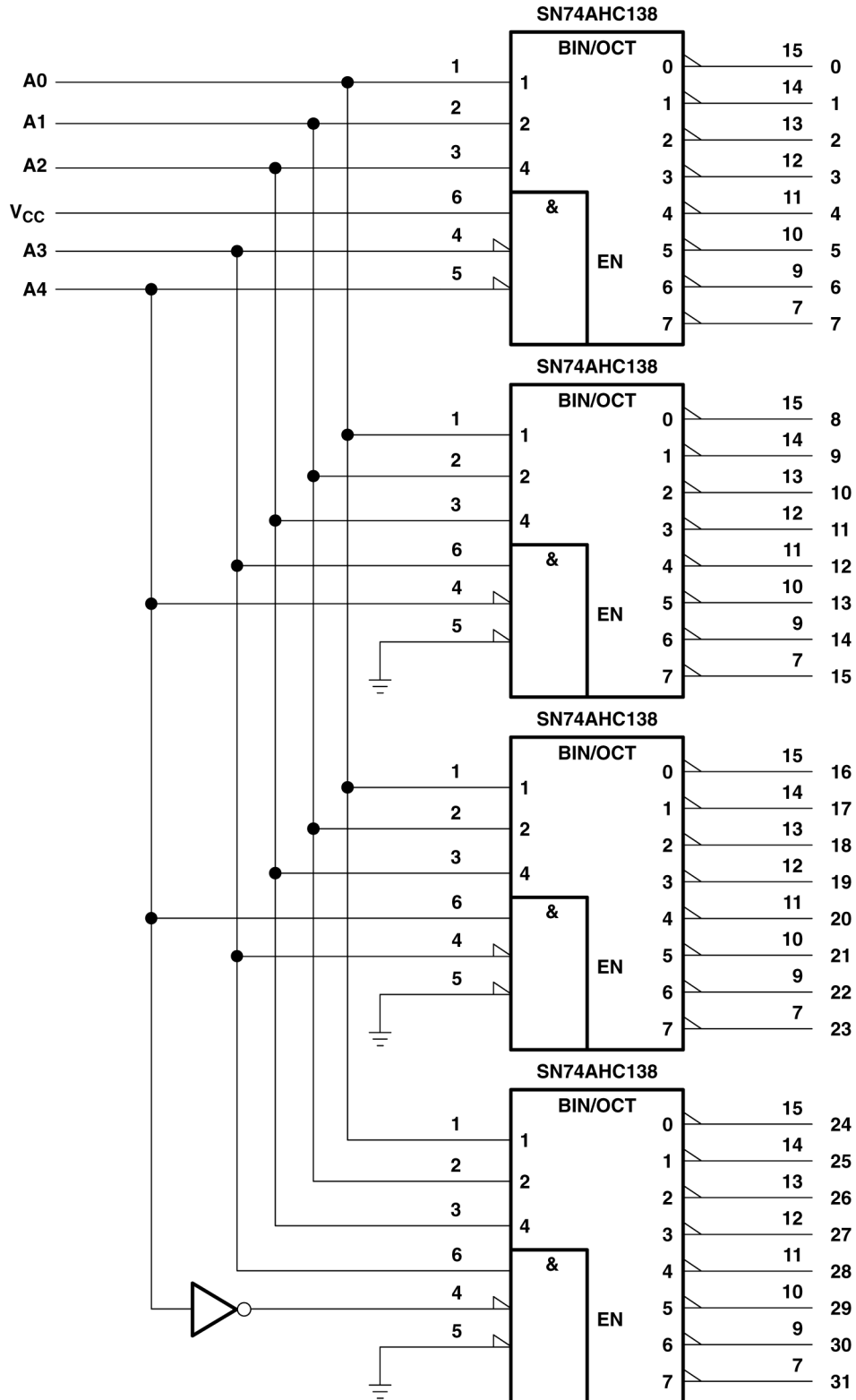

Figure 7-2. 32-Bit Decoding Scheme

## 7.2 Power Supply Recommendations

## 7.3 Layout

### 7.3.1 Layout Guidelines

When using multiple-input and multiple-channel logic devices, inputs must never be left floating. In many cases, functions or parts of functions of digital logic devices are unused; for example, when only two inputs of a triple-input AND gate are used or only 3 of the 4 buffer gates are used. Such unused input pins must not be left unconnected because the undefined voltages at the outside connections result in undefined operational states. All unused inputs of digital logic devices must be connected to a logic high or logic low voltage, as defined by the input voltage specifications, to prevent them from floating. The logic level that must be applied to any particular unused input depends on the function of the device. Generally, the inputs are tied to GND or  $V_{CC}$ , whichever makes more sense for the logic function or is more convenient.

### 7.3.2 Layout Example

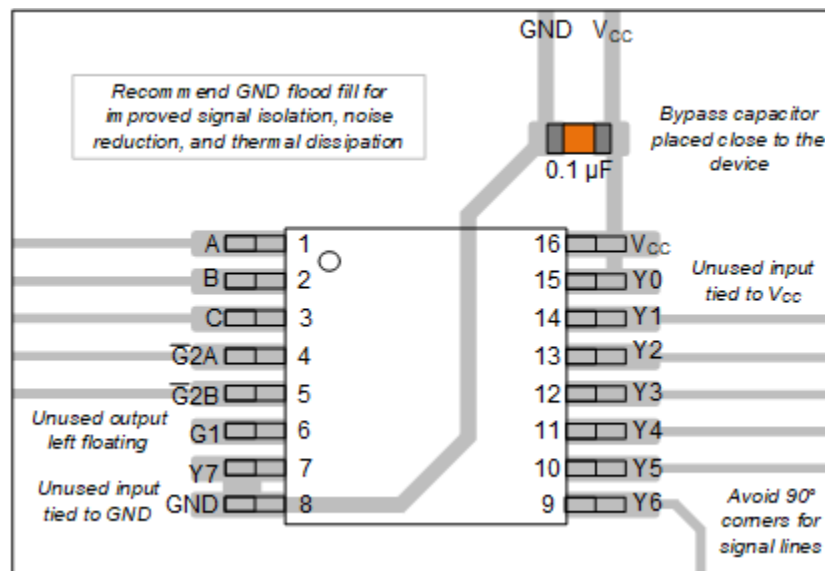

Figure 7-3. Example Layout for the SN74AHC138

## 8 Device and Documentation Support

TI offers an extensive line of development tools. Tools and software to evaluate the performance of the device, generate code, and develop solutions are listed below.

### 8.1 Documentation Support (Analog)

#### 8.1.1 Related Links

The table below lists quick access links. Categories include technical documents, support and community resources, tools and software, and quick access to sample or buy.

**Table 8-1. Related Links**

PARTS	PRODUCT FOLDER	SAMPLE & BUY	TECHNICAL DOCUMENTS	TOOLS & SOFTWARE	SUPPORT & COMMUNITY
SN54AHC138	<a href="#">Click here</a>	<a href="#">Click here</a>	<a href="#">Click here</a>	<a href="#">Click here</a>	<a href="#">Click here</a>
SN74AHC138	<a href="#">Click here</a>	<a href="#">Click here</a>	<a href="#">Click here</a>	<a href="#">Click here</a>	<a href="#">Click here</a>

### 8.2 Receiving Notification of Documentation Updates

To receive notification of documentation updates, navigate to the device product folder on [ti.com](#). Click on *Notifications* to register and receive a weekly digest of any product information that has changed. For change details, review the revision history included in any revised document.

### 8.3 Support Resources

[TI E2E™ support forums](#) are an engineer's go-to source for fast, verified answers and design help — straight from the experts. Search existing answers or ask your own question to get the quick design help you need.

Linked content is provided "AS IS" by the respective contributors. They do not constitute TI specifications and do not necessarily reflect TI's views; see TI's [Terms of Use](#).

### 8.4 Trademarks

TI E2E™ is a trademark of Texas Instruments.  
All trademarks are the property of their respective owners.

### 8.5 Electrostatic Discharge Caution



This integrated circuit can be damaged by ESD. Texas Instruments recommends that all integrated circuits be handled with appropriate precautions. Failure to observe proper handling and installation procedures can cause damage.

ESD damage can range from subtle performance degradation to complete device failure. Precision integrated circuits may be more susceptible to damage because very small parametric changes could cause the device not to meet its published specifications.

### 8.6 Glossary

[TI Glossary](#) This glossary lists and explains terms, acronyms, and definitions.

## 9 Revision History

NOTE: Page numbers for previous revisions may differ from page numbers in the current version.

Changes from Revision L (July 2003) to Revision M (April 2024)	Page
• Added <i>Package Information</i> table, <i>Pin Functions</i> table, <i>ESD Ratings</i> table, <i>Thermal Information</i> table, <i>Device Functional Modes</i> , Application and Implementation section, <i>Device and Documentation Support</i> section, and <i>Mechanical, Packaging, and Orderable Information</i> section .....	1
• Removed references to machine model.....	1
• Updated thermal values for PW package from RθJA = 108 to 135.9, all values in °C/W .....	6

## **10 Mechanical, Packaging, and Orderable Information**

The following pages include mechanical, packaging, and orderable information. This information is the most current data available for the designated devices. This data is subject to change without notice and revision of this document. For browser-based versions of this data sheet, refer to the left-hand navigation.

**PACKAGING INFORMATION**

Orderable Device	Status (1)	Package Type	Package Drawing	Pins	Package Qty	Eco Plan (2)	Lead finish/ Ball material (6)	MSL Peak Temp (3)	Op Temp (°C)	Device Marking (4/5)	Samples
5962-9851601Q2A	ACTIVE	LCCC	FK	20	55	Non-RoHS & Green	SNPB	N / A for Pkg Type	-55 to 125	5962-9851601Q2A SNJ54AHC 138FK	<a href="#">Samples</a>
5962-9851601QEA	ACTIVE	CDIP	J	16	25	Non-RoHS & Green	SNPB	N / A for Pkg Type	-55 to 125	5962-9851601QE A SNJ54AHC138J	<a href="#">Samples</a>
5962-9851601QFA	ACTIVE	CFP	W	16	25	Non-RoHS & Green	SNPB	N / A for Pkg Type	-55 to 125	5962-9851601QF A SNJ54AHC138W	<a href="#">Samples</a>
SN74AHC138DBR	ACTIVE	SSOP	DB	16	2000	RoHS & Green	NIPDAU	Level-1-260C-UNLIM	-40 to 85	HA138	<a href="#">Samples</a>
SN74AHC138DGVR	ACTIVE	TVSOP	DGV	16	2000	RoHS & Green	NIPDAU	Level-1-260C-UNLIM	-40 to 85	HA138	<a href="#">Samples</a>
SN74AHC138DR	ACTIVE	SOIC	D	16	2500	RoHS & Green	NIPDAU	Level-1-260C-UNLIM	-40 to 85	AHC138	<a href="#">Samples</a>
SN74AHC138N	ACTIVE	PDIP	N	16	25	RoHS & Green	NIPDAU	N / A for Pkg Type	-40 to 85	SN74AHC138N	<a href="#">Samples</a>
SN74AHC138NSR	ACTIVE	SO	NS	16	2000	RoHS & Green	NIPDAU	Level-1-260C-UNLIM	-40 to 85	AHC138	<a href="#">Samples</a>
SN74AHC138PWR	ACTIVE	TSSOP	PW	16	2000	RoHS & Green	NIPDAU	Level-1-260C-UNLIM	-40 to 85	HA138	<a href="#">Samples</a>
SN74AHC138RGYR	ACTIVE	VQFN	RGY	16	3000	RoHS & Green	NIPDAU	Level-2-260C-1 YEAR	-40 to 85	HA138	<a href="#">Samples</a>
SNJ54AHC138FK	ACTIVE	LCCC	FK	20	55	Non-RoHS & Green	SNPB	N / A for Pkg Type	-55 to 125	5962-9851601Q2A SNJ54AHC 138FK	<a href="#">Samples</a>
SNJ54AHC138J	ACTIVE	CDIP	J	16	25	Non-RoHS & Green	SNPB	N / A for Pkg Type	-55 to 125	5962-9851601QE A SNJ54AHC138J	<a href="#">Samples</a>
SNJ54AHC138W	ACTIVE	CFP	W	16	25	Non-RoHS & Green	SNPB	N / A for Pkg Type	-55 to 125	5962-9851601QF A SNJ54AHC138W	<a href="#">Samples</a>

(1) The marketing status values are defined as follows:

**ACTIVE:** Product device recommended for new designs.

**LIFEBUY:** TI has announced that the device will be discontinued, and a lifetime-buy period is in effect.

**NRND:** Not recommended for new designs. Device is in production to support existing customers, but TI does not recommend using this part in a new design.

**PREVIEW:** Device has been announced but is not in production. Samples may or may not be available.

**OBSOLETE:** TI has discontinued the production of the device.

<sup>(2)</sup> **RoHS:** TI defines "RoHS" to mean semiconductor products that are compliant with the current EU RoHS requirements for all 10 RoHS substances, including the requirement that RoHS substance do not exceed 0.1% by weight in homogeneous materials. Where designed to be soldered at high temperatures, "RoHS" products are suitable for use in specified lead-free processes. TI may reference these types of products as "Pb-Free".

**RoHS Exempt:** TI defines "RoHS Exempt" to mean products that contain lead but are compliant with EU RoHS pursuant to a specific EU RoHS exemption.

**Green:** TI defines "Green" to mean the content of Chlorine (Cl) and Bromine (Br) based flame retardants meet JS709B low halogen requirements of  $\leq 1000$ ppm threshold. Antimony trioxide based flame retardants must also meet the  $\leq 1000$ ppm threshold requirement.

<sup>(3)</sup> MSL, Peak Temp. - The Moisture Sensitivity Level rating according to the JEDEC industry standard classifications, and peak solder temperature.

<sup>(4)</sup> There may be additional marking, which relates to the logo, the lot trace code information, or the environmental category on the device.

<sup>(5)</sup> Multiple Device Markings will be inside parentheses. Only one Device Marking contained in parentheses and separated by a "~" will appear on a device. If a line is indented then it is a continuation of the previous line and the two combined represent the entire Device Marking for that device.

<sup>(6)</sup> Lead finish/Ball material - Orderable Devices may have multiple material finish options. Finish options are separated by a vertical ruled line. Lead finish/Ball material values may wrap to two lines if the finish value exceeds the maximum column width.

**Important Information and Disclaimer:** The information provided on this page represents TI's knowledge and belief as of the date that it is provided. TI bases its knowledge and belief on information provided by third parties, and makes no representation or warranty as to the accuracy of such information. Efforts are underway to better integrate information from third parties. TI has taken and continues to take reasonable steps to provide representative and accurate information but may not have conducted destructive testing or chemical analysis on incoming materials and chemicals. TI and TI suppliers consider certain information to be proprietary, and thus CAS numbers and other limited information may not be available for release.

In no event shall TI's liability arising out of such information exceed the total purchase price of the TI part(s) at issue in this document sold by TI to Customer on an annual basis.

**OTHER QUALIFIED VERSIONS OF SN54AHC138, SN74AHC138 :**

● Catalog : [SN74AHC138](#)

● Automotive : [SN74AHC138-Q1](#), [SN74AHC138-Q1](#)

● Military : [SN54AHC138](#)

NOTE: Qualified Version Definitions:

- Catalog - TI's standard catalog product
- Automotive - Q100 devices qualified for high-reliability automotive applications targeting zero defects
- Military - QML certified for Military and Defense Applications

**TAPE AND REEL INFORMATION**

**QUADRANT ASSIGNMENTS FOR PIN 1 ORIENTATION IN TAPE**

\*All dimensions are nominal

Device	Package Type	Package Drawing	Pins	SPQ	Reel Diameter (mm)	Reel Width W1 (mm)	A0 (mm)	B0 (mm)	K0 (mm)	P1 (mm)	W (mm)	Pin1 Quadrant
SN74AHC138DBR	SSOP	DB	16	2000	330.0	16.4	8.35	6.6	2.4	12.0	16.0	Q1
SN74AHC138DGVR	TVSOP	DGV	16	2000	330.0	12.4	6.8	4.0	1.6	8.0	12.0	Q1
SN74AHC138DR	SOIC	D	16	2500	330.0	16.4	6.5	10.3	2.1	8.0	16.0	Q1
SN74AHC138NSR	SO	NS	16	2000	330.0	16.4	8.2	10.5	2.5	12.0	16.0	Q1
SN74AHC138PWR	TSSOP	PW	16	2000	330.0	12.4	6.9	5.6	1.6	8.0	12.0	Q1
SN74AHC138RGYR	VQFN	RGY	16	3000	330.0	12.4	3.8	4.3	1.5	8.0	12.0	Q1

**TAPE AND REEL BOX DIMENSIONS**

\*All dimensions are nominal

Device	Package Type	Package Drawing	Pins	SPQ	Length (mm)	Width (mm)	Height (mm)
SN74AHC138DBR	SSOP	DB	16	2000	356.0	356.0	35.0
SN74AHC138DGVR	TVSOP	DGV	16	2000	356.0	356.0	35.0
SN74AHC138DR	SOIC	D	16	2500	340.5	336.1	32.0
SN74AHC138NSR	SO	NS	16	2000	356.0	356.0	35.0
SN74AHC138PWR	TSSOP	PW	16	2000	356.0	356.0	35.0
SN74AHC138RGYR	VQFN	RGY	16	3000	356.0	356.0	35.0

**TUBE**

\*All dimensions are nominal

Device	Package Name	Package Type	Pins	SPQ	L (mm)	W (mm)	T (μm)	B (mm)
5962-9851601Q2A	FK	LCCC	20	55	506.98	12.06	2030	NA
5962-9851601QFA	W	CFP	16	25	506.98	26.16	6220	NA
SN74AHC138N	N	PDIP	16	25	506	13.97	11230	4.32
SN74AHC138N	N	PDIP	16	25	506	13.97	11230	4.32
SNJ54AHC138FK	FK	LCCC	20	55	506.98	12.06	2030	NA
SNJ54AHC138W	W	CFP	16	25	506.98	26.16	6220	NA



# PACKAGE OUTLINE

## NS0016A

### SOP - 2.00 mm max height

SOP



4220735/A 12/2021

#### NOTES:

1. All linear dimensions are in millimeters. Dimensions in parenthesis are for reference only. Dimensioning and tolerancing per ASME Y14.5M.
2. This drawing is subject to change without notice.
3. This dimension does not include mold flash, protrusions, or gate burrs. Mold flash, protrusions, or gate burrs shall not exceed 0.15 mm, per side.
4. This dimension does not include interlead flash. Interlead flash shall not exceed 0.25 mm, per side.

# EXAMPLE BOARD LAYOUT

NS0016A

SOP - 2.00 mm max height

SOP



4220735/A 12/2021

NOTES: (continued)

5. Publication IPC-7351 may have alternate designs.

6. Solder mask tolerances between and around signal pads can vary based on board fabrication site.

# EXAMPLE STENCIL DESIGN

NS0016A

SOP - 2.00 mm max height

SOP



SOLDER PASTE EXAMPLE  
BASED ON 0.125 mm THICK STENCIL  
SCALE:7X

4220735/A 12/2021

NOTES: (continued)

7. Laser cutting apertures with trapezoidal walls and rounded corners may offer better paste release. IPC-7525 may have alternate design recommendations.
8. Board assembly site may have different recommendations for stencil design.

D (R-PDSO-G16)

PLASTIC SMALL OUTLINE



- NOTES:
- A. All linear dimensions are in inches (millimeters).
  - B. This drawing is subject to change without notice.
  - C. Body length does not include mold flash, protrusions, or gate burrs. Mold flash, protrusions, or gate burrs shall not exceed 0.006 (0,15) each side.
  - D. Body width does not include interlead flash. Interlead flash shall not exceed 0.017 (0,43) each side.
  - E. Reference JEDEC MS-012 variation AC.



4220204/A 02/2017

NOTES:

1. All linear dimensions are in millimeters. Any dimensions in parenthesis are for reference only. Dimensioning and tolerancing per ASME Y14.5M.
2. This drawing is subject to change without notice.
3. This dimension does not include mold flash, protrusions, or gate burrs. Mold flash, protrusions, or gate burrs shall not exceed 0.15 mm per side.
4. This dimension does not include interlead flash. Interlead flash shall not exceed 0.25 mm per side.
5. Reference JEDEC registration MO-153.

# EXAMPLE BOARD LAYOUT

PW0016A

TSSOP - 1.2 mm max height

SMALL OUTLINE PACKAGE



LAND PATTERN EXAMPLE  
EXPOSED METAL SHOWN  
SCALE: 10X



4220204/A 02/2017

NOTES: (continued)

- 6. Publication IPC-7351 may have alternate designs.
- 7. Solder mask tolerances between and around signal pads can vary based on board fabrication site.

# EXAMPLE STENCIL DESIGN

PW0016A

TSSOP - 1.2 mm max height

SMALL OUTLINE PACKAGE



SOLDER PASTE EXAMPLE  
BASED ON 0.125 mm THICK STENCIL  
SCALE: 10X

4220204/A 02/2017

NOTES: (continued)

8. Laser cutting apertures with trapezoidal walls and rounded corners may offer better paste release. IPC-7525 may have alternate design recommendations.
9. Board assembly site may have different recommendations for stencil design.

# DB0016A



# PACKAGE OUTLINE

## SSOP - 2 mm max height

SMALL OUTLINE PACKAGE



4220763/A 05/2022

### NOTES:

1. All linear dimensions are in millimeters. Any dimensions in parenthesis are for reference only. Dimensioning and tolerancing per ASME Y14.5M.
2. This drawing is subject to change without notice.
3. This dimension does not include mold flash, protrusions, or gate burrs. Mold flash, protrusions, or gate burrs shall not exceed 0.15 mm per side.
4. Reference JEDEC registration MO-150.

# EXAMPLE BOARD LAYOUT

DB0016A

SSOP - 2 mm max height

SMALL OUTLINE PACKAGE



LAND PATTERN EXAMPLE  
EXPOSED METAL SHOWN  
SCALE: 10X



4220763/A 05/2022

NOTES: (continued)

- 5. Publication IPC-7351 may have alternate designs.
- 6. Solder mask tolerances between and around signal pads can vary based on board fabrication site.

# EXAMPLE STENCIL DESIGN

DB0016A

SSOP - 2 mm max height

SMALL OUTLINE PACKAGE



SOLDER PASTE EXAMPLE  
BASED ON 0.125 mm THICK STENCIL  
SCALE: 10X

4220763/A 05/2022

NOTES: (continued)

7. Laser cutting apertures with trapezoidal walls and rounded corners may offer better paste release. IPC-7525 may have alternate design recommendations.
8. Board assembly site may have different recommendations for stencil design.

# MECHANICAL DATA

NS (R-PDSO-G\*\*)

PLASTIC SMALL-OUTLINE PACKAGE

14-PINS SHOWN



- NOTES:
- A. All linear dimensions are in millimeters.
  - B. This drawing is subject to change without notice.
  - C. Body dimensions do not include mold flash or protrusion, not to exceed 0,15.

DGV (R-PDSO-G\*\*)

PLASTIC SMALL-OUTLINE

24 PINS SHOWN



- NOTES: A. All linear dimensions are in millimeters.  
 B. This drawing is subject to change without notice.  
 C. Body dimensions do not include mold flash or protrusion, not to exceed 0,15 per side.  
 D. Falls within JEDEC: 24/48 Pins – MO-153  
 14/16/20/56 Pins – MO-194

W (R-GDFP-F16)

CERAMIC DUAL FLATPACK

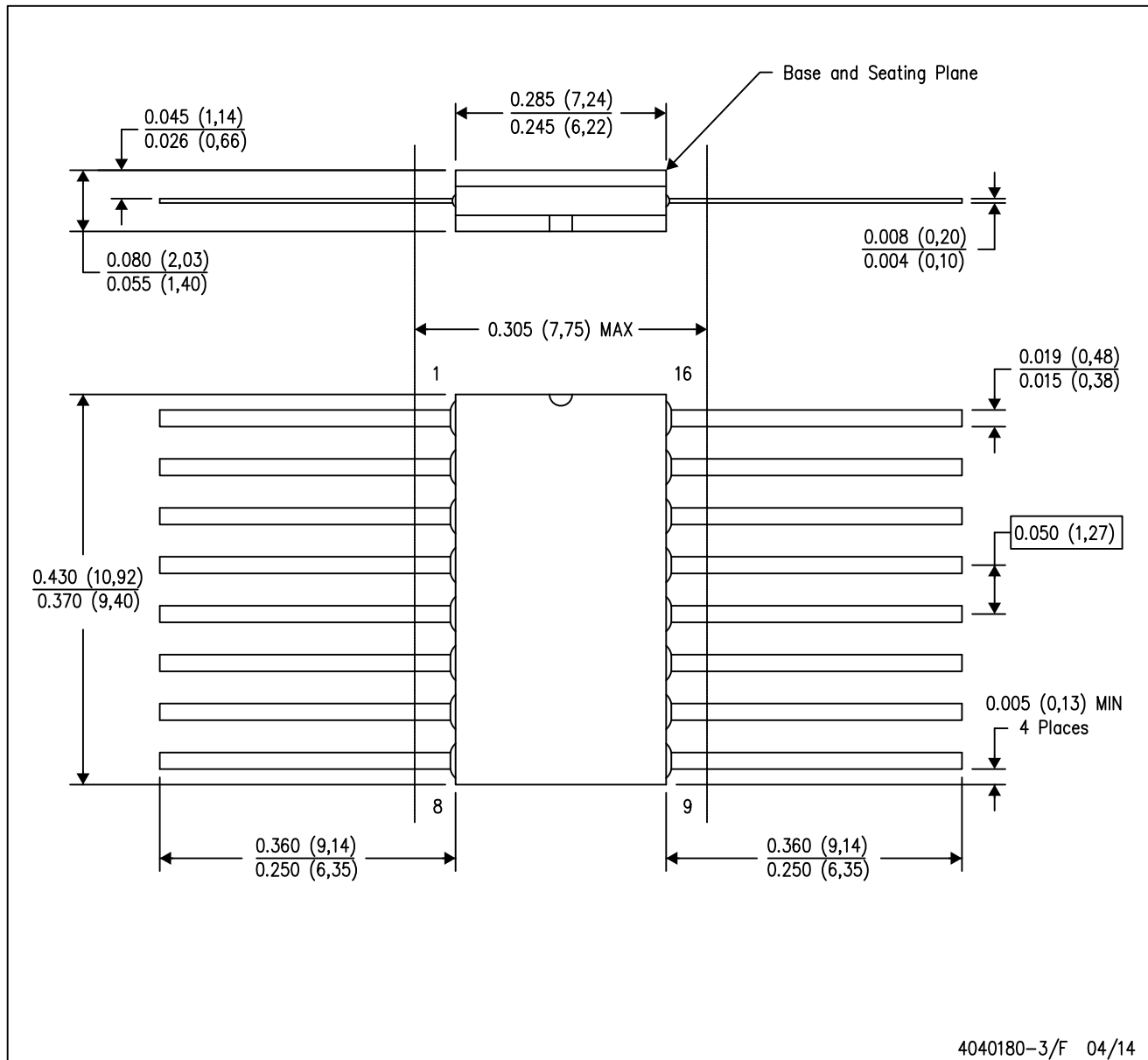

- NOTES:
- A. All linear dimensions are in inches (millimeters).
  - B. This drawing is subject to change without notice.
  - C. This package can be hermetically sealed with a ceramic lid using glass frit.
  - D. Index point is provided on cap for terminal identification only.
  - E. Falls within MIL STD 1835 GDFP2-F16

## GENERIC PACKAGE VIEW

**FK 20**

**LCCC - 2.03 mm max height**

8.89 x 8.89, 1.27 mm pitch

LEADLESS CERAMIC CHIP CARRIER

This image is a representation of the package family, actual package may vary.  
Refer to the product data sheet for package details.

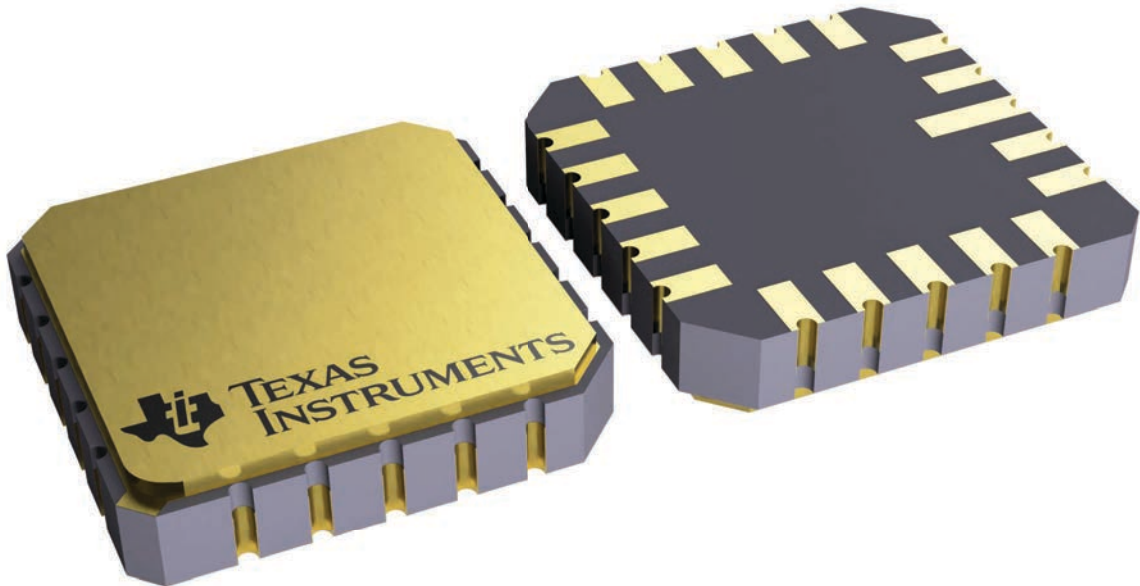

4229370VA\

J (R-GDIP-T\*\*)

14 LEADS SHOWN

CERAMIC DUAL IN-LINE PACKAGE

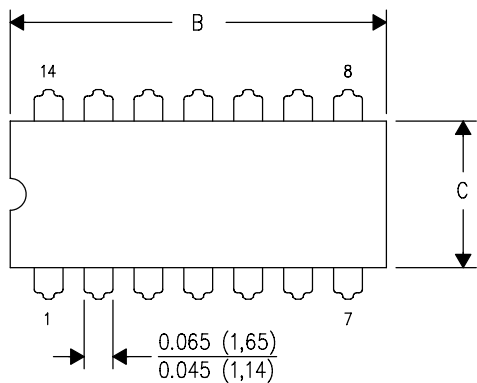

DIM \ PINS **	14	16	18	20
A	0.300 (7,62) BSC	0.300 (7,62) BSC	0.300 (7,62) BSC	0.300 (7,62) BSC
B MAX	0.785 (19,94)	.840 (21,34)	0.960 (24,38)	1.060 (26,92)
B MIN	—	—	—	—
C MAX	0.300 (7,62)	0.300 (7,62)	0.310 (7,87)	0.300 (7,62)
C MIN	0.245 (6,22)	0.245 (6,22)	0.220 (5,59)	0.245 (6,22)

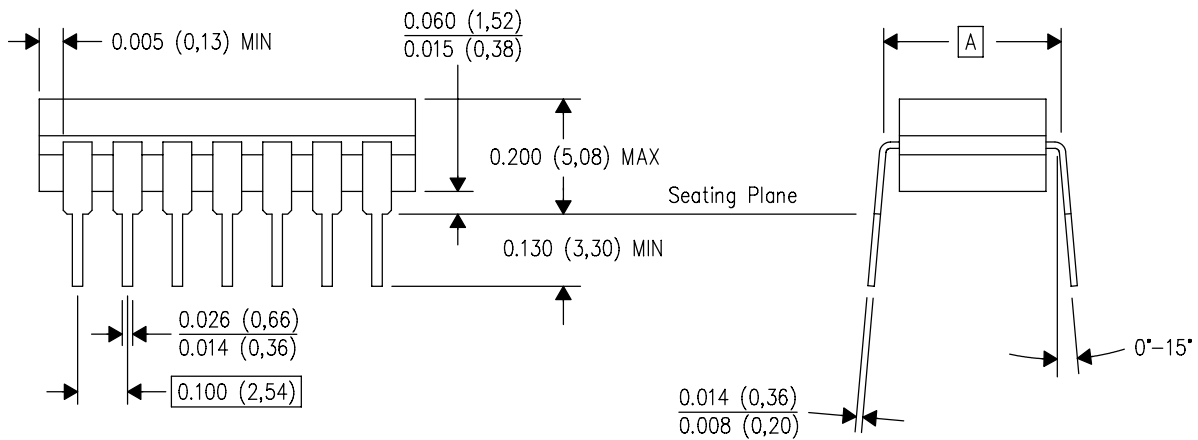

4040083/F 03/03

- NOTES:
- All linear dimensions are in inches (millimeters).
  - This drawing is subject to change without notice.
  - This package is hermetically sealed with a ceramic lid using glass frit.
  - Index point is provided on cap for terminal identification only on press ceramic glass frit seal only.
  - Falls within MIL STD 1835 GDIP1-T14, GDIP1-T16, GDIP1-T18 and GDIP1-T20.

N (R-PDIP-T\*\*)

PLASTIC DUAL-IN-LINE PACKAGE

16 PINS SHOWN



- NOTES:
- A. All linear dimensions are in inches (millimeters).
  - B. This drawing is subject to change without notice.
  - Falls within JEDEC MS-001, except 18 and 20 pin minimum body length (Dim A).
  - The 20 pin end lead shoulder width is a vendor option, either half or full width.

RGY (R-PVQFN-N16)

PLASTIC QUAD FLATPACK NO-LEAD

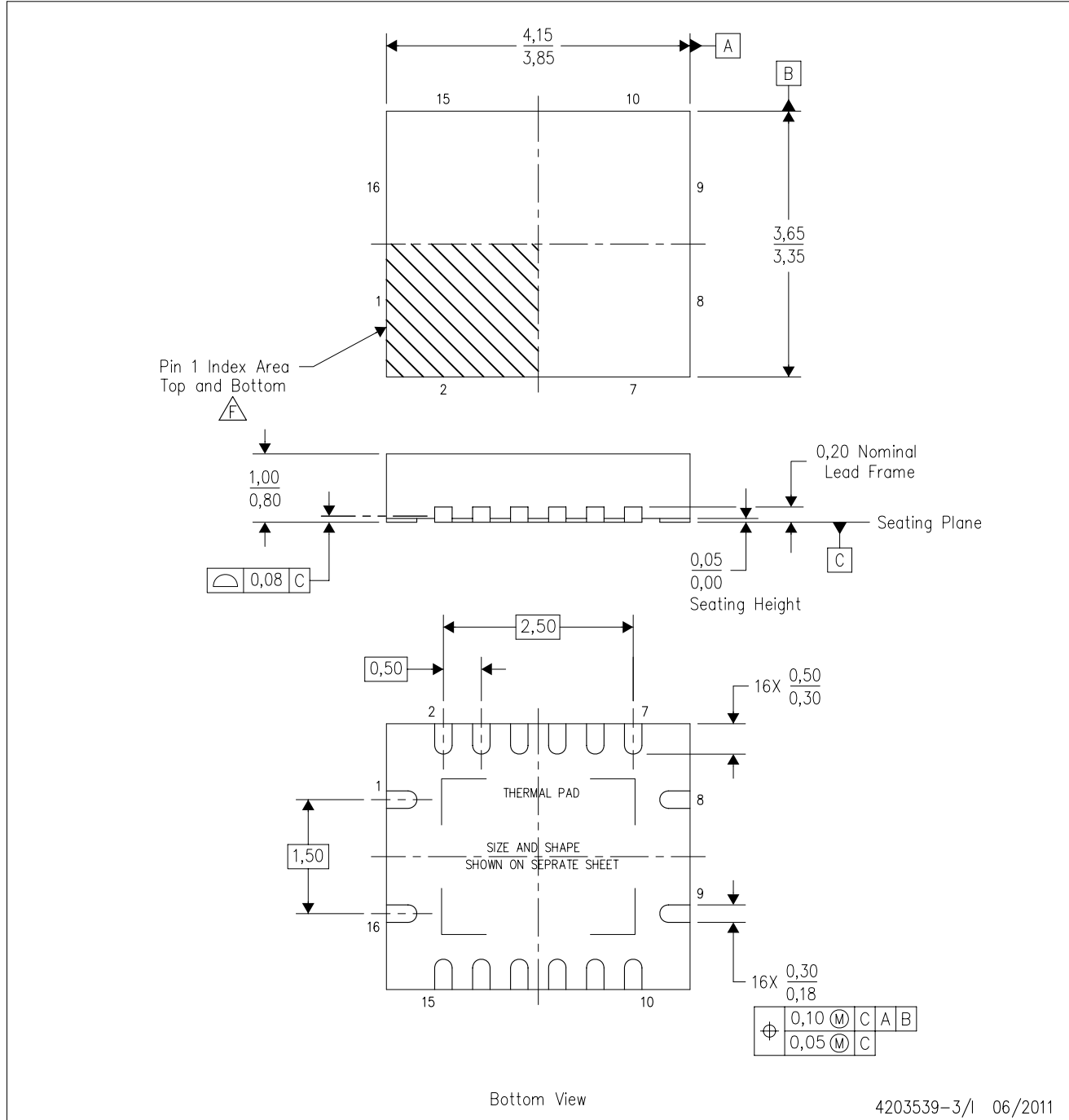

4203539-3/1 06/2011

- NOTES:
- All linear dimensions are in millimeters. Dimensioning and tolerancing per ASME Y14.5M-1994.
  - This drawing is subject to change without notice.
  - QFN (Quad Flatpack No-Lead) package configuration.
  - The package thermal pad must be soldered to the board for thermal and mechanical performance.
  - See the additional figure in the Product Data Sheet for details regarding the exposed thermal pad features and dimensions.
  - Pin 1 identifiers are located on both top and bottom of the package and within the zone indicated. The Pin 1 identifiers are either a molded, marked, or metal feature.
  - Package complies to JEDEC MO-241 variation BA.

RGY (R-PVQFN-N16)

PLASTIC QUAD FLATPACK NO-LEAD

**THERMAL INFORMATION**

This package incorporates an exposed thermal pad that is designed to be attached directly to an external heatsink. The thermal pad must be soldered directly to the printed circuit board (PCB). After soldering, the PCB can be used as a heatsink. In addition, through the use of thermal vias, the thermal pad can be attached directly to the appropriate copper plane shown in the electrical schematic for the device, or alternatively, can be attached to a special heatsink structure designed into the PCB. This design optimizes the heat transfer from the integrated circuit (IC).

For information on the Quad Flatpack No-Lead (QFN) package and its advantages, refer to Application Report, QFN/SON PCB Attachment, Texas Instruments Literature No. SLUA271. This document is available at [www.ti.com](http://www.ti.com).

The exposed thermal pad dimensions for this package are shown in the following illustration.

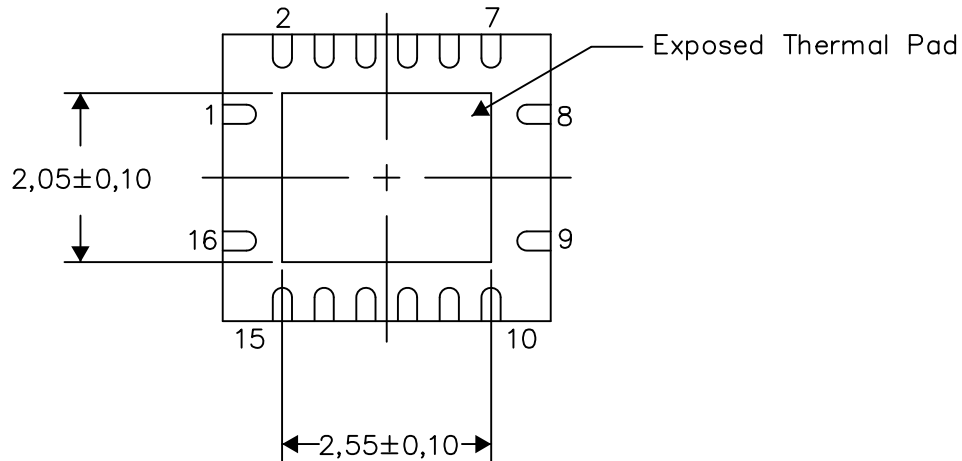

Bottom View

Exposed Thermal Pad Dimensions

4206353-3/P 03/14

NOTE: All linear dimensions are in millimeters

RGY (R-PVQFN-N16)

PLASTIC QUAD FLATPACK NO-LEAD

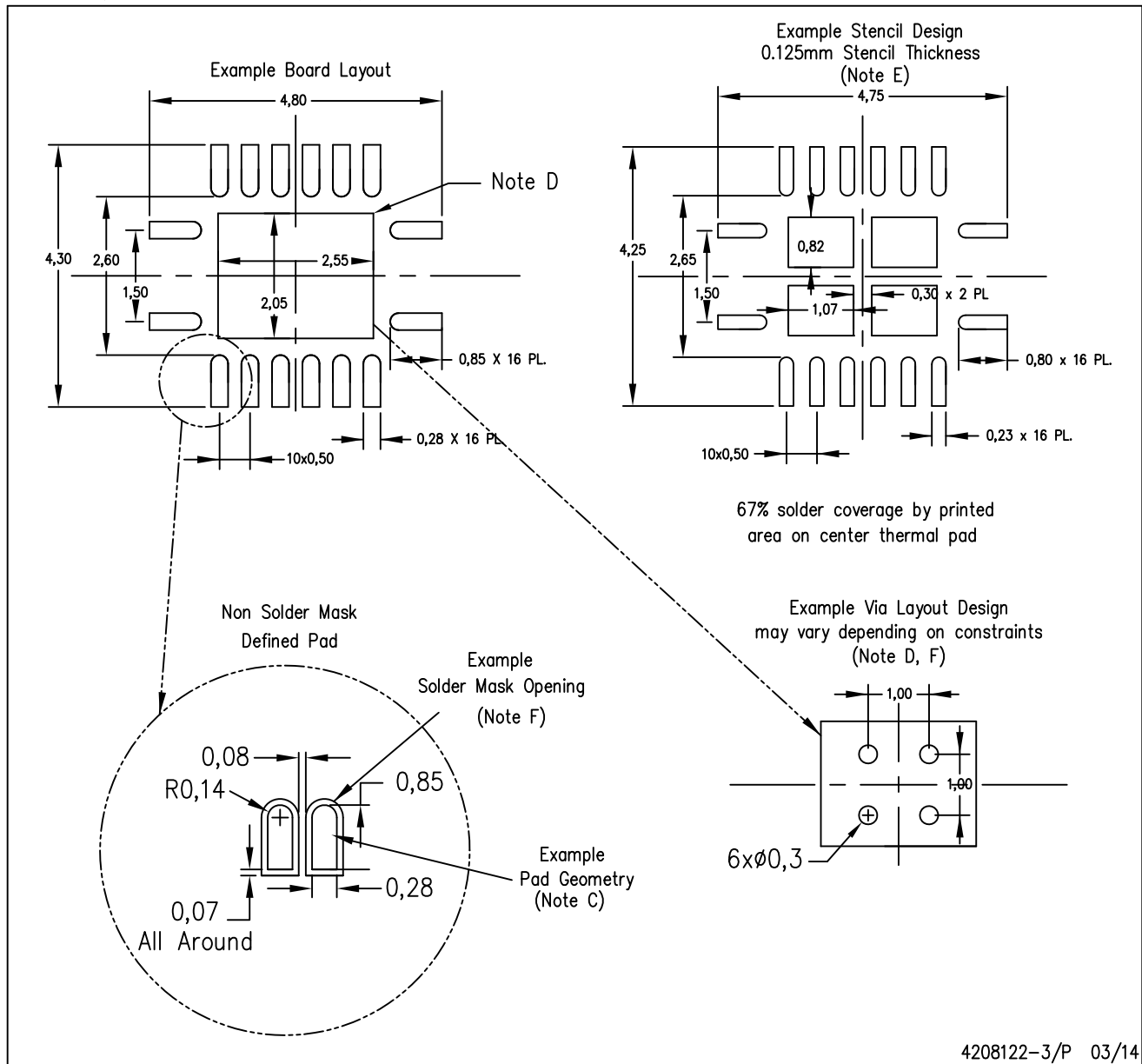

4208122-3/P 03/14

- NOTES:
- All linear dimensions are in millimeters.
  - This drawing is subject to change without notice.
  - Publication IPC-7351 is recommended for alternate designs.
  - This package is designed to be soldered to a thermal pad on the board. Refer to Application Note, Quad Flat-Pack QFN/SON PCB Attachment, Texas Instruments Literature No. SLUA271, and also the Product Data Sheets for specific thermal information, via requirements, and recommended board layout. These documents are available at [www.ti.com](http://www.ti.com) <<http://www.ti.com>>.
  - Laser cutting apertures with trapezoidal walls and also rounding corners will offer better paste release. Customers should contact their board assembly site for stencil design recommendations. Refer to IPC 7525 for stencil design considerations.
  - Customers should contact their board fabrication site for minimum solder mask web tolerances between signal pads.

## IMPORTANT NOTICE AND DISCLAIMER

TI PROVIDES TECHNICAL AND RELIABILITY DATA (INCLUDING DATA SHEETS), DESIGN RESOURCES (INCLUDING REFERENCE DESIGNS), APPLICATION OR OTHER DESIGN ADVICE, WEB TOOLS, SAFETY INFORMATION, AND OTHER RESOURCES "AS IS" AND WITH ALL FAULTS, AND DISCLAIMS ALL WARRANTIES, EXPRESS AND IMPLIED, INCLUDING WITHOUT LIMITATION ANY IMPLIED WARRANTIES OF MERCHANTABILITY, FITNESS FOR A PARTICULAR PURPOSE OR NON-INFRINGEMENT OF THIRD PARTY INTELLECTUAL PROPERTY RIGHTS.

These resources are intended for skilled developers designing with TI products. You are solely responsible for (1) selecting the appropriate TI products for your application, (2) designing, validating and testing your application, and (3) ensuring your application meets applicable standards, and any other safety, security, regulatory or other requirements.

These resources are subject to change without notice. TI grants you permission to use these resources only for development of an application that uses the TI products described in the resource. Other reproduction and display of these resources is prohibited. No license is granted to any other TI intellectual property right or to any third party intellectual property right. TI disclaims responsibility for, and you will fully indemnify TI and its representatives against, any claims, damages, costs, losses, and liabilities arising out of your use of these resources.

TI's products are provided subject to [TI's Terms of Sale](#) or other applicable terms available either on [ti.com](https://www.ti.com) or provided in conjunction with such TI products. TI's provision of these resources does not expand or otherwise alter TI's applicable warranties or warranty disclaimers for TI products.

TI objects to and rejects any additional or different terms you may have proposed.

Mailing Address: Texas Instruments, Post Office Box 655303, Dallas, Texas 75265  
Copyright © 2024, Texas Instruments Incorporated

## Looking for pricing, stock, or lifecycle information?

Click below to explore more details on WIN SOURCE:

 [View SN74AHC138PWR on WIN SOURCE](#)

 [Texas Instruments](#) Information

## Optimize Your Supply Chain with WIN SOURCE Solutions

-  Global Sourcing Solution
-  Obsolete Management
-  Cost Control Management
-  Shortage Management
-  Alternative Solution
-  Excess Inventory Management