



THE DATASHEET OF SN74HC244DBR



SNx4HC244 Octal Buffers and Line Drivers With 3-State Outputs

1 Features

- Wide Operating Voltage Range of 2 V to 6 V
- High-Current Outputs Drive Up to 15 LSTTL Loads
- 3-State Outputs Drive Bus Lines or Buffer Memory Address Registers
- Low Power Consumption: I_{CC} , 80- μ A (Maximum)
- Typical t_{pd} = 11 ns
- ± 6 -mA Output Drive at 5 V
- Low Input Current of 1 μ A (Maximum)
- On Products Compliant to MIL-PRF-38535, All Parameters Are Tested Unless Otherwise Noted. On All Other Products, Production Processing Does Not Necessarily Include Testing of All Parameters.

2 Applications

- Servers
- LED Displays
- Network Switches
- Telecom Infrastructure
- Motor Drivers
- I/O Expanders

3 Description

The SNx4HC244 octal buffers and line drivers are designed specifically to improve both the performance and density of 3-state memory address drivers, clock drivers, and bus-oriented receivers and transmitters. The SNx4HC244 devices are organized as two 4-bit buffers and drivers with separate output-enable (\overline{OE}) inputs. When \overline{OE} is low, the device passes noninverted data from the A inputs to the Y outputs. When \overline{OE} is high, the outputs are in the high-impedance state.

Device Information

PART NUMBER	PACKAGE (PINS) ⁽¹⁾	BODY SIZE (NOM)
SN54HC244	CDIP (20)	6.92 mm × 24.38 mm
	CFP (20)	6.92 mm × 13.72 mm
	LCCC (20)	8.89 mm × 8.89 mm
SN74HC244DB	SSOP (20)	5.30 mm × 7.25 mm
SN74HC244DW	SOIC (20)	7.50 mm × 12.80 mm
SN74HC244N	PDIP (20)	6.30 mm × 25.40 mm
SN74HC244NS	SOP (20)	5.30 mm × 12.60 mm
SN74HC244PW	TSSOP (20)	4.40 mm × 6.50 mm

(1) For all available packages, see the orderable addendum at the end of the data sheet.

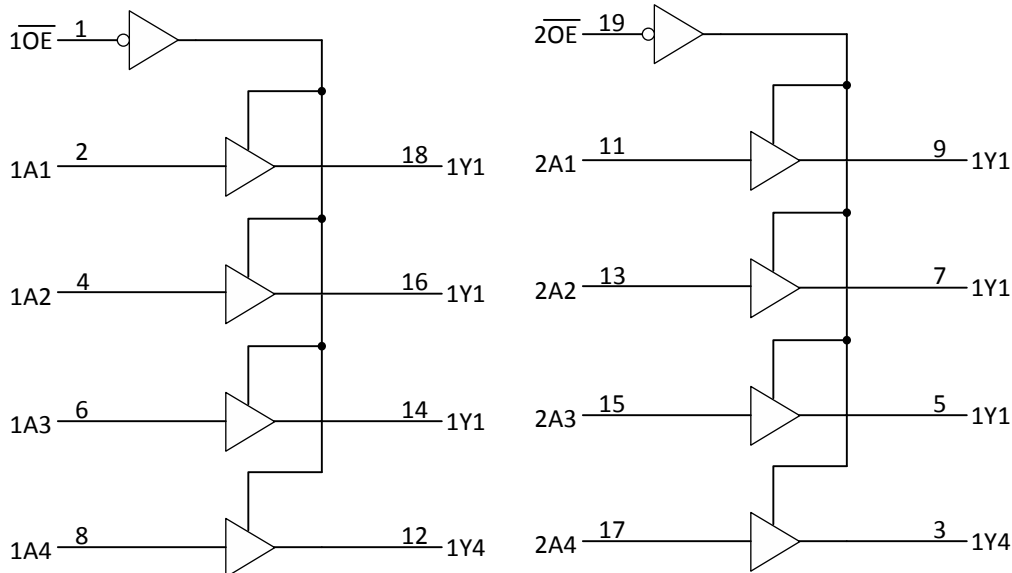

Copyright © 2016, Texas Instruments Incorporated

Logic Diagram (Positive Logic)



Table of Contents

1 Features	1	8.1 Overview.....	12
2 Applications	1	8.2 Functional Block Diagram.....	12
3 Description	1	8.3 Feature Description.....	12
4 Revision History	2	8.4 Device Functional Modes.....	12
5 Pin Configuration and Functions	3	9 Application and Implementation	13
Pin Functions.....	3	9.1 Application Information.....	13
6 Specifications	4	9.2 Typical Application.....	13
6.1 Absolute Maximum Ratings.....	4	10 Power Supply Recommendations	14
6.2 ESD Ratings.....	4	11 Layout	14
6.3 Recommended Operating Conditions.....	4	11.1 Layout Guidelines.....	14
6.4 Thermal Information.....	5	11.2 Layout Example.....	14
6.5 Electrical Characteristics.....	5	12 Device and Documentation Support	15
6.6 Electrical Characteristics – SN54HC244.....	5	12.1 Documentation Support.....	15
6.7 Electrical Characteristics – SN74HC244.....	6	12.2 Receiving Notification of Documentation Updates..	15
6.8 Switching Characteristics.....	6	12.3 Support Resources.....	15
6.9 Switching Characteristics – $C_L = 50$ pF.....	8	12.4 Trademarks.....	15
6.10 Switching Characteristics – $C_L = 150$ pF.....	8	12.5 Electrostatic Discharge Caution.....	15
6.11 Typical Characteristic.....	9	12.6 Glossary.....	15
7 Parameter Measurement Information	10	13 Mechanical, Packaging, and Orderable Information	15
8 Detailed Description	12		

4 Revision History

NOTE: Page numbers for previous revisions may differ from page numbers in the current version.

Changes from Revision E (May 2016) to Revision F (May 2022)	Page
• Junction-to-ambient thermal resistance values increased to match current function.....	5

Changes from Revision D (August 2003) to Revision E (May 2016)	Page
• Added <i>ESD Ratings</i> table, <i>Feature Description</i> section, <i>Device Functional Modes</i> , <i>Application and Implementation</i> section, <i>Power Supply Recommendations</i> section, <i>Layout</i> section, <i>Device and Documentation Support</i> section, and <i>Mechanical, Packaging, and Orderable Information</i> section.....	1
• Added Military Disclaimer to <i>Features</i> section.....	1
• Added <i>Applications</i> section.....	1
• Removed Ordering Information table.....	1
• Added <i>Device Information</i> table.....	1

5 Pin Configuration and Functions

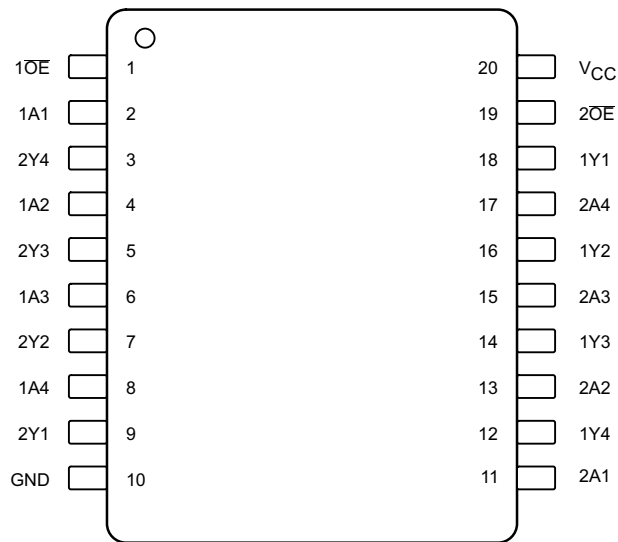

Figure 5-1. DB, DW, J, N, NS, PW, W Package 20-Pin SSOP, SOIC, CDIP, PDIP, SOP, TSSOP, or CFP Top View

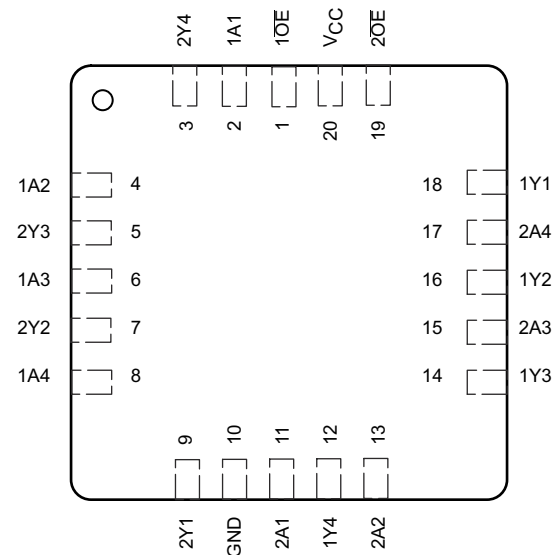

Figure 5-2. FK Package 20-Pin LCCC Top View

Pin Functions

PIN		I/O ⁽¹⁾	DESCRIPTION
NO.	NAME		
1	1 \overline{OE}	I	Output Enable
2	1A1	I	Input
3	2Y4	O	Output
4	1A2	I	Input
5	2Y3	O	Output
6	1A3	I	Input
7	2Y2	O	Output
8	1A4	I	Input
9	2Y1	O	Output
10	GND	—	Ground
11	2A1	I	Input
12	1Y4	O	Output
13	2A2	I	Input
14	1Y3	O	Output
15	2A3	I	Input
16	1Y2	O	Output
17	2A4	I	Input
18	1Y1	O	Output
19	2 \overline{OE}	I	Output Enable
20	V _{CC}	—	Power Pin

(1) Signal Types: I = Input, O = Output, I/O = Input or Output.

6 Specifications

6.1 Absolute Maximum Ratings

over operating free-air temperature range (unless otherwise noted)⁽¹⁾

		MIN	MAX	UNIT
Supply voltage range, V_{CC}		-0.5	7	V
Input clamp current, I_{IK}	$V_I < 0$ or $V_I > V_{CC}$ ⁽²⁾		±20	mA
Output clamp current, I_{OK}	$V_O < 0$ or $V_O > V_{CC}$ ⁽²⁾		±20	mA
Continuous output current, I_O	$V_O = 0$ or V_{CC}		±35	mA
Continuous current through V_{CC} or GND			±70	mA
Junction Temperature, T_J			150	°C
Storage temperature, T_{stg}		-65	150	°C

- (1) Stresses beyond those listed under *Absolute Maximum Ratings* may cause permanent damage to the device. These are stress ratings only, which do not imply functional operation of the device at these or any other conditions beyond those indicated under *Recommended Operating Conditions*. Exposure to absolute-maximum-rated conditions for extended periods may affect device reliability.
- (2) The input and output voltage ratings may be exceeded if the input and output current ratings are observed.

6.2 ESD Ratings

		SN74HC244	VALUE	UNIT
$V_{(ESD)}$	Electrostatic discharge	Human-body model (HBM), per ANSI/ESDA/JEDEC JS-001 ⁽¹⁾	±2000	V
		Charged-device model (CDM), per JEDEC specification JESD22-C101 ⁽²⁾	±1000	

- (1) JEDEC document JEP155 states that 500-V HBM allows safe manufacturing with a standard ESD control process.
- (2) JEDEC document JEP157 states that 250-V CDM allows safe manufacturing with a standard ESD control process.

6.3 Recommended Operating Conditions

over operating free-air temperature range (unless otherwise noted)⁽¹⁾

		MIN	NOM	MAX	UNIT
V_{CC}	Supply voltage	2	5	6	V
V_{IH}	High-level input voltage	$V_{CC} = 2$ V	1.5		V
		$V_{CC} = 4.5$ V	3.15		
		$V_{CC} = 6$ V	4.2		
V_{IL}	Low-level input voltage	$V_{CC} = 2$ V		0.5	V
		$V_{CC} = 4.5$ V		1.35	
		$V_{CC} = 6$ V		1.8	
V_I	Input voltage	0		V_{CC}	V
V_O	Output voltage	0		V_{CC}	V
$\Delta t/\Delta v$	Input transition rise and fall time	$V_{CC} = 2$ V		1000	ns/V
		$V_{CC} = 4.5$ V		500	
		$V_{CC} = 6$ V		400	
C_{pd}	Power dissipation capacitance per buffer or driver (no load)		35		pF
T_A	Operating free-air temperature	SN54HC244	-55	125	°C
		SN74HC244	-40	85	

- (1) All unused inputs of the device must be held at V_{CC} or GND to ensure proper device operation. See the Texas Instruments application report, *Implications of Slow or Floating CMOS Inputs*, [SCBA004](#).

6.4 Thermal Information

THERMAL METRIC		SN74HC244					UNIT
		DW (SOIC)	DB (SSOP)	N (PDIP)	NS (SO)	PW (TSSOP)	
		20 PINS	20 PINS	20 PINS	20 PINS	20 PINS	
$R_{\theta JA}$	Junction-to-ambient thermal resistance ⁽¹⁾	109.1	122.7	84.6	113.4	131.8	°C/W
$R_{\theta JC (top)}$	Junction-to-case (top) thermal resistance	76	81.6	72.5	78.6	72.2	°C/W
$R_{\theta JB}$	Junction-to-board thermal resistance	77.6	77.5	65.3	78.4	82.8	°C/W
Ψ_{JT}	Junction-to-top characterization parameter	51.5	46.1	55.3	47.1	21.5	°C/W
Ψ_{JB}	Junction-to-board characterization parameter	77.1	77.1	65.2	78.1	82.4	°C/W
$R_{\theta JC (bot)}$	Junction-to-case (bottom) thermal resistance	N/A	N/A	N/A	N/A	N/A	°C/W

(1) For more information about traditional and new thermal metrics, see the *Semiconductor and IC Package Thermal Metrics* application report, [SPRA953](#).

6.5 Electrical Characteristics

$T_A = 25^\circ\text{C}$ (unless otherwise noted)

PARAMETER	TEST CONDITIONS		MIN	TYP	MAX	UNIT
V_{OH}	$V_I = V_{IH}$ or V_{IL}	$I_{OH} = -20 \mu\text{A}$	$V_{CC} = 2 \text{ V}$	1.9	1.998	V
			$V_{CC} = 4.5 \text{ V}$	4.4	4.499	
			$V_{CC} = 6 \text{ V}$	5.9	5.999	
		$I_{OH} = -6 \text{ mA}, V_{CC} = 4.5 \text{ V}$	3.98	4.3		
		$I_{OH} = -7.8 \text{ mA}, V_{CC} = 6 \text{ V}$	5.48	5.8		
V_{OL}	$V_I = V_{IH}$ or V_{IL}	$I_{OL} = 20 \mu\text{A}$	$V_{CC} = 2 \text{ V}$	0.002	0.1	V
			$V_{CC} = 4.5 \text{ V}$	0.001	0.1	
			$V_{CC} = 6 \text{ V}$	0.001	0.1	
		$I_{OL} = 6 \text{ mA}, V_{CC} = 4.5 \text{ V}$	0.17	0.26		
		$I_{OL} = 7.8 \text{ mA}, V_{CC} = 6 \text{ V}$	0.15	0.26		
I_I	$V_I = V_{CC}$ or 0, $V_{CC} = 6 \text{ V}$			± 0.1	± 100	nA
I_{OZ}	$V_O = V_{CC}$ or 0, $V_I = V_{IH}$ or V_{IL} , $V_{CC} = 6 \text{ V}$			± 0.01	± 0.5	μA
I_{CC}	$V_I = V_{CC}$ or 0, $I_O = 0$, $V_{CC} = 6 \text{ V}$				8	μA
C_i	$V_{CC} = 2 \text{ V}$ to 6 V			3	10	pF

6.6 Electrical Characteristics – SN54HC244

over recommended operating free-air temperature range (unless otherwise noted)

PARAMETER	TEST CONDITIONS		MIN	TYP	MAX	UNIT
V_{OH}	$V_I = V_{IH}$ or V_{IL}	$I_{OH} = -20 \mu\text{A}$	$V_{CC} = 2 \text{ V}$	1.9		V
			$V_{CC} = 4.5 \text{ V}$	4.4		
			$V_{CC} = 6 \text{ V}$	5.9		
		$I_{OH} = -6 \text{ mA}, V_{CC} = 4.5 \text{ V}$	3.7			
		$I_{OH} = -7.8 \text{ mA}, V_{CC} = 6 \text{ V}$	5.2			

over recommended operating free-air temperature range (unless otherwise noted)

PARAMETER	TEST CONDITIONS		MIN	TYP	MAX	UNIT
V_{OL}	$V_I = V_{IH}$ or V_{IL}	$I_{OL} = 20 \mu A$	$V_{CC} = 2 V$		0.1	V
			$V_{CC} = 4.5 V$		0.1	
			$V_{CC} = 6 V$		0.1	
		$I_{OL} = 6 mA, V_{CC} = 4.5 V$			0.4	
		$I_{OL} = 7.8 mA, V_{CC} = 6 V$		0.4		
I_I	$V_I = V_{CC}$ or 0, $V_{CC} = 6 V$				± 1000	nA
I_{OZ}	$V_O = V_{CC}$ or 0, $V_I = V_{IH}$ or V_{IL} , $V_{CC} = 6 V$				± 10	μA
I_{CC}	$V_I = V_{CC}$ or 0, $I_O = 0$, $V_{CC} = 6 V$				160	μA
C_i	$V_{CC} = 2 V$ to $6 V$				10	pF

6.7 Electrical Characteristics – SN74HC244

over recommended operating free-air temperature range (unless otherwise noted)

PARAMETER	TEST CONDITIONS		MIN	TYP	MAX	UNIT
V_{OH}	$V_I = V_{IH}$ or V_{IL}	$I_{OH} = -20 \mu A$	$V_{CC} = 2 V$	1.9		V
			$V_{CC} = 4.5 V$	4.4		
			$V_{CC} = 6 V$	5.9		
		$I_{OH} = -6 mA, V_{CC} = 4.5 V$		3.84		
		$I_{OH} = -7.8 mA, V_{CC} = 6 V$	5.34			
V_{OL}	$V_I = V_{IH}$ or V_{IL}	$I_{OL} = 20 \mu A$	$V_{CC} = 2 V$		0.1	V
			$V_{CC} = 4.5 V$		0.1	
			$V_{CC} = 6 V$		0.1	
		$I_{OL} = 6 mA, V_{CC} = 4.5 V$			0.33	
		$I_{OL} = 7.8 mA, V_{CC} = 6 V$		0.33		
I_I	$V_I = V_{CC}$ or 0, $V_{CC} = 6 V$				± 1000	nA
I_{OZ}	$V_O = V_{CC}$ or 0, $V_I = V_{IH}$ or V_{IL} , $V_{CC} = 6 V$				± 5	μA
I_{CC}	$V_I = V_{CC}$ or 0, $I_O = 0$, $V_{CC} = 6 V$				80	μA
C_i	$V_{CC} = 2 V$ to $6 V$				10	pF

6.8 Switching Characteristics

$T_A = 25^\circ C$ (unless otherwise noted; see Figure 7-1)

PARAMETER	TEST CONDITIONS		MIN	TYP	MAX	UNIT
t_{pd}	From A (input) to Y (output)	$V_{CC} = 2 V$	$C_L = 50 pF$	40	115	ns
			$C_L = 150 pF$	56	165	
		$V_{CC} = 4.5 V$	$C_L = 50 pF$	13	23	
			$C_L = 150 pF$	18	33	
		$V_{CC} = 6 V$	$C_L = 50 pF$	11	20	
			$C_L = 150 pF$	15	28	
t_{en}	From \overline{OE} (input) to Y (output)	$V_{CC} = 2 V$	$C_L = 50 pF$	75	150	ns
			$C_L = 150 pF$	100	200	
		$V_{CC} = 4.5 V$	$C_L = 50 pF$	15	30	
			$C_L = 150 pF$	20	40	
		$V_{CC} = 6 V$	$C_L = 50 pF$	13	26	
			$C_L = 150 pF$	17	34	

$T_A = 25^\circ\text{C}$ (unless otherwise noted; see [Figure 7-1](#))

PARAMETER	TEST CONDITIONS		MIN	TYP	MAX	UNIT
t_{dis}	From $\overline{\text{OE}}$ (input) to Y (output)	$V_{\text{CC}} = 2\text{ V}$	$C_L = 50\text{ pF}$	75	150	ns
		$V_{\text{CC}} = 4.5\text{ V}$	$C_L = 50\text{ pF}$	15	30	
		$V_{\text{CC}} = 6\text{ V}$	$C_L = 50\text{ pF}$	13	26	
t_t	To Y (output)	$V_{\text{CC}} = 2\text{ V}$	$C_L = 50\text{ pF}$	28	60	ns
			$C_L = 150\text{ pF}$	45	210	
		$V_{\text{CC}} = 4.5\text{ V}$	$C_L = 50\text{ pF}$	8	12	
			$C_L = 150\text{ pF}$	17	42	
		$V_{\text{CC}} = 6\text{ V}$	$C_L = 50\text{ pF}$	6	10	
			$C_L = 150\text{ pF}$	13	36	

6.9 Switching Characteristics – $C_L = 50$ pF

over recommended operating free-air temperature range (unless otherwise noted; see [Figure 7-1](#))

PARAMETER	TEST CONDITIONS		MIN	TYP	MAX	UNIT
t_{pd}	From A (input) to Y (output)	$V_{CC} = 2$ V	SN54HC244		170	ns
			SN74HC244		145	
		$V_{CC} = 4.5$ V	SN54HC244		34	
			SN74HC244		29	
		$V_{CC} = 6$ V	SN54HC244		29	
			SN74HC244		25	
t_{en}	From \overline{OE} (input) to Y (output)	$V_{CC} = 2$ V	SN54HC244		225	ns
			SN74HC244		190	
		$V_{CC} = 4.5$ V	SN54HC244		45	
			SN74HC244		38	
		$V_{CC} = 6$ V	SN54HC244		38	
			SN74HC244		32	
t_{dis}	From \overline{OE} (input) to Y (output)	$V_{CC} = 2$ V	SN54HC244		225	ns
			SN74HC244		190	
		$V_{CC} = 4.5$ V	SN54HC244		45	
			SN74HC244		38	
		$V_{CC} = 6$ V	SN54HC244		38	
			SN74HC244		32	
t_t	To Y (output)	$V_{CC} = 2$ V	SN54HC244		90	ns
			SN74HC244		75	
		$V_{CC} = 4.5$ V	SN54HC244		18	
			SN74HC244		15	
		$V_{CC} = 6$ V	SN54HC244		15	
			SN74HC244		13	

6.10 Switching Characteristics – $C_L = 150$ pF

over recommended operating free-air temperature range (unless otherwise noted; see [Figure 7-1](#))

PARAMETER	TEST CONDITIONS		MIN	TYP	MAX	UNIT
t_{pd}	From A (input) to Y (output)	$V_{CC} = 2$ V	SN54HC244		245	ns
			SN74HC244		210	
		$V_{CC} = 4.5$ V	SN54HC244		49	
			SN74HC244		42	
		$V_{CC} = 6$ V	SN54HC244		42	
			SN74HC244		35	
t_{en}	From \overline{OE} (input) to Y (output)	$V_{CC} = 2$ V	SN54HC244		300	ns
			SN74HC244		250	
		$V_{CC} = 4.5$ V	SN54HC244		60	
			SN74HC244		50	
		$V_{CC} = 6$ V	SN54HC244		51	
			SN74HC244		43	

over recommended operating free-air temperature range (unless otherwise noted; see [Figure 7-1](#))

PARAMETER	TEST CONDITIONS		MIN	TYP	MAX	UNIT
t_t	To Y (output)	$V_{CC} = 2\text{ V}$	SN54HC244		315	ns
			SN74HC244		265	
		$V_{CC} = 4.5\text{ V}$	SN54HC244		63	
			SN74HC244		53	
		$V_{CC} = 6\text{ V}$	SN54HC244		53	
			SN74HC244		45	

6.11 Typical Characteristic

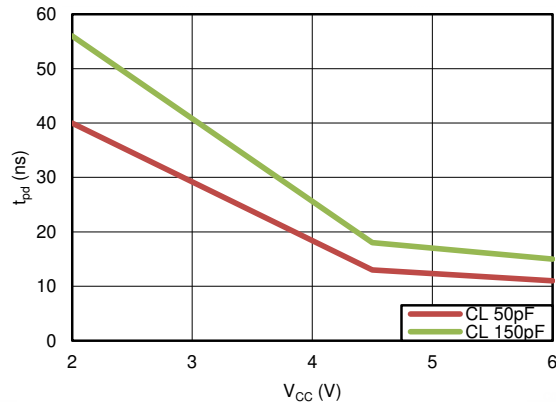

Figure 6-1. Propagation Delay

7 Parameter Measurement Information

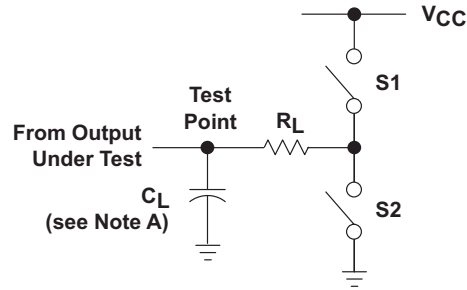

Figure 7-1. Load Circuit

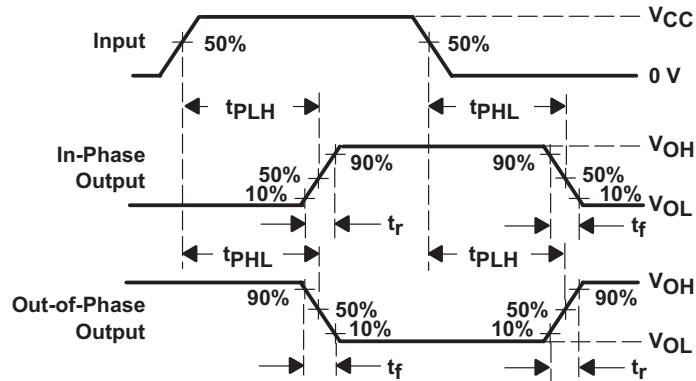

Figure 7-2. Propagation Delay and Output Transition Times

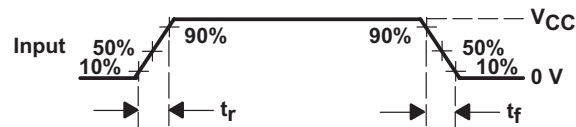

Figure 7-3. Input Rise and Fall Times

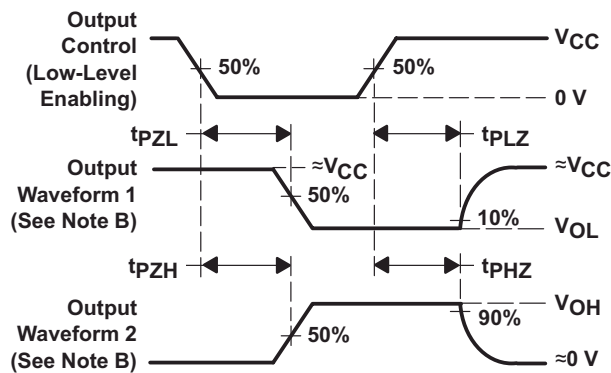

Figure 7-4. Enable and Disable Times for 3-State Outputs

Note

NOTE:

- A. C_L includes probe and test-fixture capacitance.
- B. Waveform 1 is for an output with internal conditions such that the output is low except when disabled by the output control. Waveform 2 is for an output with internal conditions such that the output is high except when disabled by the output control.
- C. Phase relationships between waveforms were chosen arbitrarily. All input pulses are supplied by generators having the following characteristics: $PRR \leq 1$ MHz, $Z_O = 50 \Omega$, $t_r = 6$ ns, $t_f = 6$ ns.
- D. The outputs are measured one at a time with one input transition per measurement.
- E. t_{PLZ} and t_{PHZ} are the same as t_{dis} .
- F. t_{PZL} and t_{PZH} are the same as t_{en} .
- G. t_{PLH} and t_{PHL} are the same as t_{pd} .

Table 7-1. Switching Information Table

PARAMETER		RL	CL	S1	S2
t_{en}	t_{PZH}	1 k Ω	50 pF or 150 pF	Open	Closed
	t_{PZL}	1 k Ω	50 pF or 150 pF	Closed	Open
t_{dis}	t_{PHZ}	1 k Ω	50 pF	Open	Closed
	t_{PLZ}	1 k Ω	50 pF	Closed	Open
t_{pd} or t_t		—	50 pF or 150 pF	Open	Open

8 Detailed Description

8.1 Overview

The SNx4HC244 device is organized as two 4-bit buffers and line drivers with separate output-enable (\overline{OE}) inputs. When \overline{OE} is low, the device passes data from the A inputs to the Y outputs. When \overline{OE} is high, the outputs are in the high-impedance state. To ensure the high-impedance state during power up or power down, \overline{OE} should be tied to V_{CC} through a pullup resistor; the minimum value of the resistor is determined by the current-sinking capability of the driver.

8.2 Functional Block Diagram

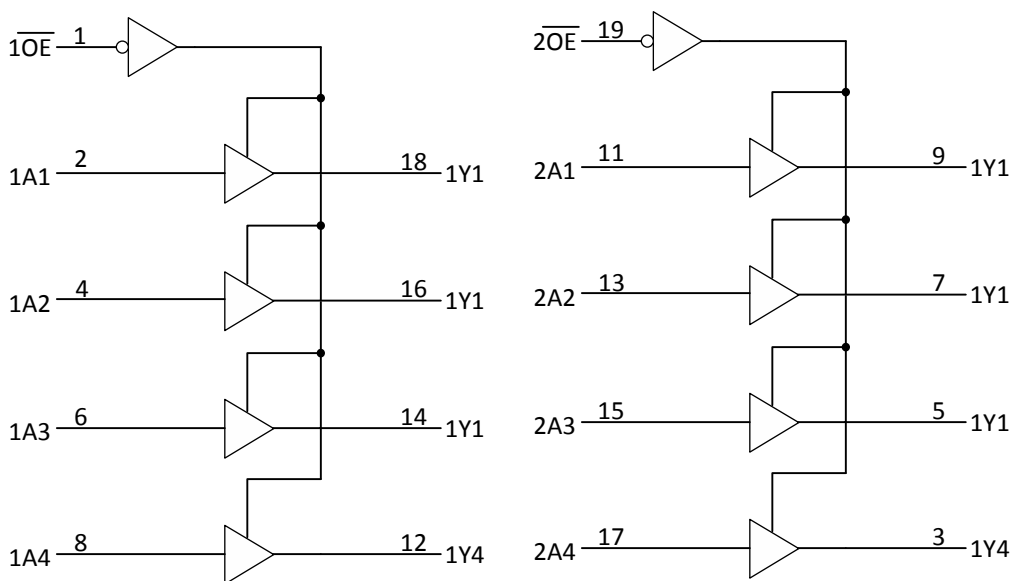

Copyright © 2016, Texas Instruments Incorporated

8.3 Feature Description

The SNx4HC244 has a wide operating voltage of 2 V to 6 V. Inputs accept voltage levels up to V_{CC} . This device has a low power consumption of I_{CC} 80 μ A (maximum). The SNx4HC244 device can drive ± 6 mA at V_{CC} of 5 V.

8.4 Device Functional Modes

Table 8-1 lists the functions of the SNx4HC244.

**Table 8-1. Function Table
(Each Buffer or Driver)**

INPUTS		OUTPUT
\overline{OE}	A	Y
L	H	H
L	L	L
H	X	Z

9 Application and Implementation

Note

Information in the following applications sections is not part of the TI component specification, and TI does not warrant its accuracy or completeness. TI's customers are responsible for determining suitability of components for their purposes, as well as validating and testing their design implementation to confirm system functionality.

9.1 Application Information

SN74HC244 is a high-drive CMOS device that can be used for a multitude of bus interface type applications where output drive or PCB trace length is a concern.

9.2 Typical Application

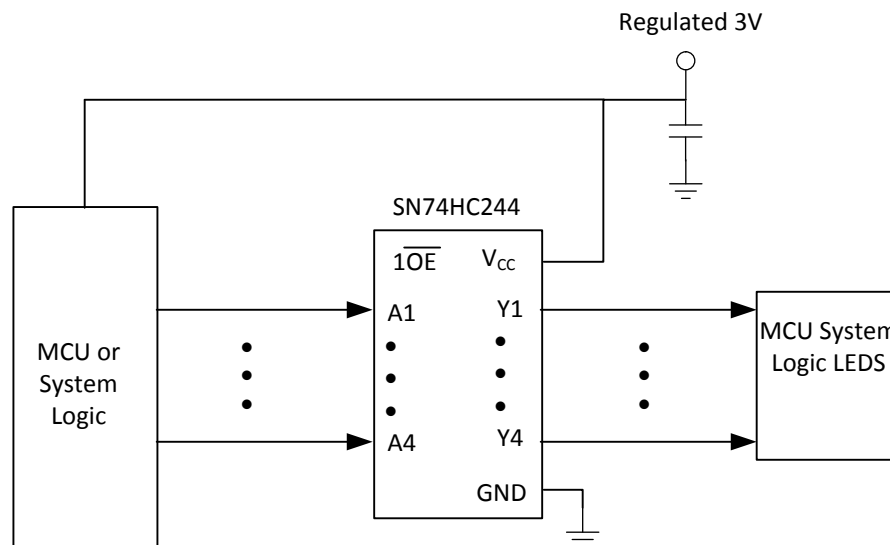

Copyright © 2016, Texas Instruments Incorporated

Figure 9-1. SN74HC244 Application Schematic

9.2.1 Design Requirements

This device uses CMOS technology and has balanced output drive. Take care to avoid bus contention because it can drive currents that would exceed maximum limits. The high drive also creates fast edges into light loads so routing and load conditions should be considered to prevent ringing.

9.2.2 Detailed Design Procedure

1. Recommended input conditions:
 - For rise time and fall time specifications, see $\Delta t/\Delta V$ in [Section 6.3](#).
 - For specified high and low levels, see V_{IH} and V_{IL} in [Section 6.3](#).
2. Recommend output conditions:
 - Load currents should not exceed I_O max per output and should not exceed the continuous current through V_{CC} or GND total current for the part. These limits are located in [Section 6.1](#).
 - Outputs should not be pulled above V_{CC} .

9.2.3 Application Curve

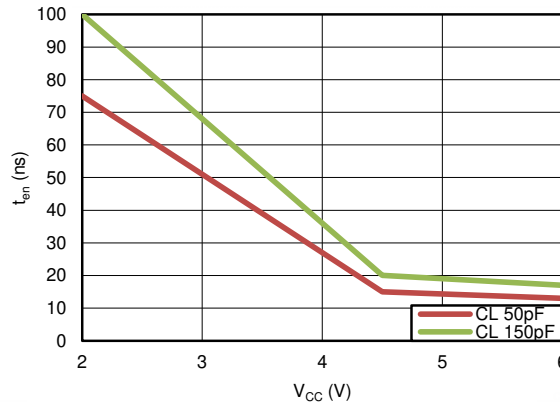

Figure 9-2. Enable Time

10 Power Supply Recommendations

The power supply can be any voltage between the MIN and MAX supply voltage rating located in the [Section 6.3](#).

Each V_{CC} terminal should have a good bypass capacitor to prevent power disturbance. For devices with a single supply, TI recommends a 0.1- μF capacitor. If there are multiple V_{CC} terminals, then TI recommends 0.01- μF or 0.022- μF capacitors for each power terminal. It is ok to parallel multiple bypass capacitors to reject different frequencies of noise. Multiple bypass capacitors may be paralleled to reject different frequencies of noise. The bypass capacitor should be installed as close to the power terminal as possible for the best results.

11 Layout

11.1 Layout Guidelines

When using multiple bit logic devices, inputs should not float. In many cases, functions or parts of functions of digital logic devices are unused. Some examples are when only two inputs of a triple-input and gate are used, or when only 3 of the 4-buffer gates are used. Such input pins should not be left unconnected because the undefined voltages at the outside connections result in undefined operational states.

Specified in [Figure 11-1](#) are rules that must be observed under all circumstances. All unused inputs of digital logic devices must be connected to a high or low bias to prevent them from floating. The logic level that should be applied to any particular unused input depends on the function of the device. Generally they will be tied to GND or V_{CC} , whichever makes more sense or is more convenient.

11.2 Layout Example

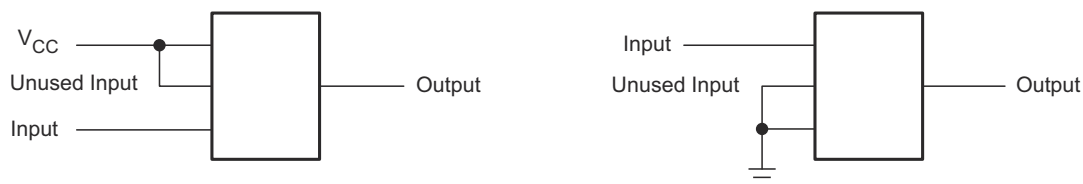

Figure 11-1. Layout Diagram

12 Device and Documentation Support

12.1 Documentation Support

12.1.1 Related Links

Table 12-1 lists quick access links. Categories include technical documents, support and community resources, tools and software, and quick access to sample or buy.

Table 12-1. Related Links

PARTS	PRODUCT FOLDER	SAMPLE & BUY	TECHNICAL DOCUMENTS	TOOLS & SOFTWARE	SUPPORT & COMMUNITY
SN54HC244	Click here	Click here	Click here	Click here	Click here
SN74HC244	Click here	Click here	Click here	Click here	Click here

12.2 Receiving Notification of Documentation Updates

To receive notification of documentation updates, navigate to the device product folder on ti.com. Click on *Subscribe to updates* to register and receive a weekly digest of any product information that has changed. For change details, review the revision history included in any revised document.

12.3 Support Resources

TI E2E™ support forums are an engineer's go-to source for fast, verified answers and design help — straight from the experts. Search existing answers or ask your own question to get the quick design help you need.

Linked content is provided "AS IS" by the respective contributors. They do not constitute TI specifications and do not necessarily reflect TI's views; see TI's [Terms of Use](#).

12.4 Trademarks

TI E2E™ is a trademark of Texas Instruments.
All trademarks are the property of their respective owners.

12.5 Electrostatic Discharge Caution



This integrated circuit can be damaged by ESD. Texas Instruments recommends that all integrated circuits be handled with appropriate precautions. Failure to observe proper handling and installation procedures can cause damage.

ESD damage can range from subtle performance degradation to complete device failure. Precision integrated circuits may be more susceptible to damage because very small parametric changes could cause the device not to meet its published specifications.

12.6 Glossary

[TI Glossary](#) This glossary lists and explains terms, acronyms, and definitions.

13 Mechanical, Packaging, and Orderable Information

The following pages include mechanical, packaging, and orderable information. This information is the most current data available for the designated devices. This data is subject to change without notice and revision of this document. For browser-based versions of this data sheet, refer to the left-hand navigation.

PACKAGING INFORMATION

Orderable Device	Status (1)	Package Type	Package Drawing	Pins	Package Qty	Eco Plan (2)	Lead finish/ Ball material (6)	MSL Peak Temp (3)	Op Temp (°C)	Device Marking (4/5)	Samples
5962-8409601VRA	ACTIVE	CDIP	J	20	20	Non-RoHS & Green	SNPB	N / A for Pkg Type	-55 to 125	5962-8409601VR A SNV54HC244J	Samples
5962-8409601VSA	ACTIVE	CFP	W	20	25	Non-RoHS & Green	SNPB	N / A for Pkg Type	-55 to 125	5962-8409601VS A SNV54HC244W	Samples
84096012A	ACTIVE	LCCC	FK	20	55	Non-RoHS & Green	SNPB	N / A for Pkg Type	-55 to 125	84096012A SNJ54HC 244FK	Samples
8409601RA	ACTIVE	CDIP	J	20	20	Non-RoHS & Green	SNPB	N / A for Pkg Type	-55 to 125	8409601RA SNJ54HC244J	Samples
8409601SA	ACTIVE	CFP	W	20	25	Non-RoHS & Green	SNPB	N / A for Pkg Type	-55 to 125	8409601SA SNJ54HC244W	Samples
JM38510/65705B2A	ACTIVE	LCCC	FK	20	55	Non-RoHS & Green	SNPB	N / A for Pkg Type	-55 to 125	JM38510/ 65705B2A	Samples
JM38510/65705BRA	ACTIVE	CDIP	J	20	20	Non-RoHS & Green	SNPB	N / A for Pkg Type	-55 to 125	JM38510/ 65705BRA	Samples
JM38510/65705BSA	ACTIVE	CFP	W	20	25	Non-RoHS & Green	SNPB	N / A for Pkg Type	-55 to 125	JM38510/ 65705BSA	Samples
M38510/65705B2A	ACTIVE	LCCC	FK	20	55	Non-RoHS & Green	SNPB	N / A for Pkg Type	-55 to 125	JM38510/ 65705B2A	Samples
M38510/65705BRA	ACTIVE	CDIP	J	20	20	Non-RoHS & Green	SNPB	N / A for Pkg Type	-55 to 125	JM38510/ 65705BRA	Samples
M38510/65705BSA	ACTIVE	CFP	W	20	25	Non-RoHS & Green	SNPB	N / A for Pkg Type	-55 to 125	JM38510/ 65705BSA	Samples
SN54HC244J	ACTIVE	CDIP	J	20	20	Non-RoHS & Green	SNPB	N / A for Pkg Type	-55 to 125	SN54HC244J	Samples
SN74HC244APWR	ACTIVE	TSSOP	PW	20	2000	RoHS & Green	NIPDAU	Level-1-260C-UNLIM	-40 to 85	HC244A	Samples
SN74HC244DBR	ACTIVE	SSOP	DB	20	2000	RoHS & Green	NIPDAU	Level-1-260C-UNLIM	-40 to 85	HC244	Samples
SN74HC244DWR	ACTIVE	SOIC	DW	20	2000	RoHS & Green	NIPDAU	Level-1-260C-UNLIM	-40 to 85	HC244	Samples
SN74HC244DWRE4	ACTIVE	SOIC	DW	20	2000	RoHS & Green	NIPDAU	Level-1-260C-UNLIM	-40 to 85	HC244	Samples

Orderable Device	Status (1)	Package Type	Package Drawing	Pins	Package Qty	Eco Plan (2)	Lead finish/ Ball material (6)	MSL Peak Temp (3)	Op Temp (°C)	Device Marking (4/5)	Samples
SN74HC244DWRG4	ACTIVE	SOIC	DW	20	2000	RoHS & Green	NIPDAU	Level-1-260C-UNLIM	-40 to 85	HC244	Samples
SN74HC244N	ACTIVE	PDIP	N	20	20	RoHS & Green	NIPDAU	N / A for Pkg Type	-40 to 85	SN74HC244N	Samples
SN74HC244NE4	ACTIVE	PDIP	N	20	20	RoHS & Green	NIPDAU	N / A for Pkg Type	-40 to 85	SN74HC244N	Samples
SN74HC244NSR	ACTIVE	SO	NS	20	2000	RoHS & Green	NIPDAU	Level-1-260C-UNLIM	-40 to 85	HC244	Samples
SN74HC244NSRG4	ACTIVE	SO	NS	20	2000	RoHS & Green	NIPDAU	Level-1-260C-UNLIM	-40 to 85	HC244	Samples
SN74HC244PWR	ACTIVE	TSSOP	PW	20	2000	RoHS & Green	NIPDAU	Level-1-260C-UNLIM	-40 to 85	HC244	Samples
SN74HC244PWRE4	ACTIVE	TSSOP	PW	20	2000	RoHS & Green	NIPDAU	Level-1-260C-UNLIM	-40 to 85	HC244	Samples
SN74HC244PWRG4	ACTIVE	TSSOP	PW	20	2000	RoHS & Green	NIPDAU	Level-1-260C-UNLIM	-40 to 85	HC244	Samples
SN74HC244QDWRG4Q1	ACTIVE	SOIC	DW	20	2000	RoHS & Green	NIPDAU	Level-1-260C-UNLIM		HC244Q	Samples
SNJ54HC244FK	ACTIVE	LCCC	FK	20	55	Non-RoHS & Green	SNPB	N / A for Pkg Type	-55 to 125	84096012A SNJ54HC 244FK	Samples
SNJ54HC244J	ACTIVE	CDIP	J	20	20	Non-RoHS & Green	SNPB	N / A for Pkg Type	-55 to 125	8409601RA SNJ54HC244J	Samples
SNJ54HC244W	ACTIVE	CFP	W	20	25	Non-RoHS & Green	SNPB	N / A for Pkg Type	-55 to 125	8409601SA SNJ54HC244W	Samples

(1) The marketing status values are defined as follows:

ACTIVE: Product device recommended for new designs.

LIFEBUY: TI has announced that the device will be discontinued, and a lifetime-buy period is in effect.

NRND: Not recommended for new designs. Device is in production to support existing customers, but TI does not recommend using this part in a new design.

PREVIEW: Device has been announced but is not in production. Samples may or may not be available.

OBSOLETE: TI has discontinued the production of the device.

(2) **RoHS:** TI defines "RoHS" to mean semiconductor products that are compliant with the current EU RoHS requirements for all 10 RoHS substances, including the requirement that RoHS substance do not exceed 0.1% by weight in homogeneous materials. Where designed to be soldered at high temperatures, "RoHS" products are suitable for use in specified lead-free processes. TI may reference these types of products as "Pb-Free".

RoHS Exempt: TI defines "RoHS Exempt" to mean products that contain lead but are compliant with EU RoHS pursuant to a specific EU RoHS exemption.

Green: TI defines "Green" to mean the content of Chlorine (Cl) and Bromine (Br) based flame retardants meet JS709B low halogen requirements of <=1000ppm threshold. Antimony trioxide based flame retardants must also meet the <=1000ppm threshold requirement.

(3) MSL, Peak Temp. - The Moisture Sensitivity Level rating according to the JEDEC industry standard classifications, and peak solder temperature.

(4) There may be additional marking, which relates to the logo, the lot trace code information, or the environmental category on the device.

(5) Multiple Device Markings will be inside parentheses. Only one Device Marking contained in parentheses and separated by a "~" will appear on a device. If a line is indented then it is a continuation of the previous line and the two combined represent the entire Device Marking for that device.

(6) Lead finish/Ball material - Orderable Devices may have multiple material finish options. Finish options are separated by a vertical ruled line. Lead finish/Ball material values may wrap to two lines if the finish value exceeds the maximum column width.

Important Information and Disclaimer:The information provided on this page represents TI's knowledge and belief as of the date that it is provided. TI bases its knowledge and belief on information provided by third parties, and makes no representation or warranty as to the accuracy of such information. Efforts are underway to better integrate information from third parties. TI has taken and continues to take reasonable steps to provide representative and accurate information but may not have conducted destructive testing or chemical analysis on incoming materials and chemicals. TI and TI suppliers consider certain information to be proprietary, and thus CAS numbers and other limited information may not be available for release.

In no event shall TI's liability arising out of such information exceed the total purchase price of the TI part(s) at issue in this document sold by TI to Customer on an annual basis.

OTHER QUALIFIED VERSIONS OF SN54HC244, SN54HC244-SP, SN74HC244 :

- Catalog : [SN74HC244](#), [SN54HC244](#)
- Automotive : [SN74HC244-Q1](#), [SN74HC244-Q1](#)
- Enhanced Product : [SN74HC244-EP](#), [SN74HC244-EP](#)
- Military : [SN54HC244](#)
- Space : [SN54HC244-SP](#)

NOTE: Qualified Version Definitions:

- Catalog - TI's standard catalog product
- Automotive - Q100 devices qualified for high-reliability automotive applications targeting zero defects
- Enhanced Product - Supports Defense, Aerospace and Medical Applications
- Military - QML certified for Military and Defense Applications

- Space - Radiation tolerant, ceramic packaging and qualified for use in Space-based application

TAPE AND REEL INFORMATION

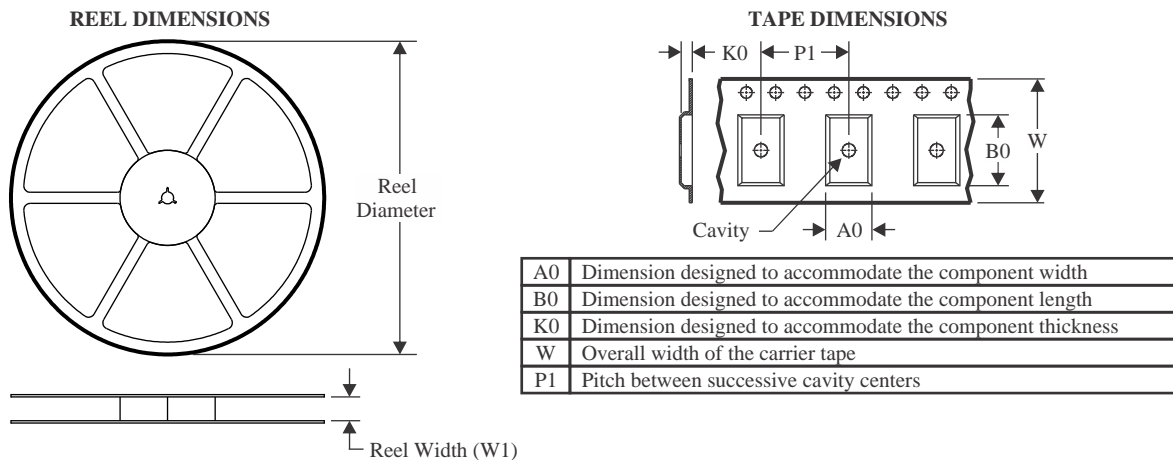

QUADRANT ASSIGNMENTS FOR PIN 1 ORIENTATION IN TAPE

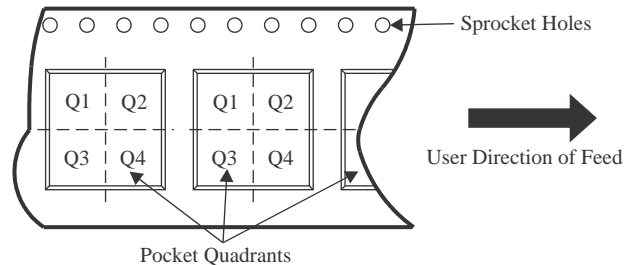

*All dimensions are nominal

Device	Package Type	Package Drawing	Pins	SPQ	Reel Diameter (mm)	Reel Width W1 (mm)	A0 (mm)	B0 (mm)	K0 (mm)	P1 (mm)	W (mm)	Pin1 Quadrant
SN74HC244APWR	TSSOP	PW	20	2000	330.0	16.4	6.95	7.1	1.6	8.0	16.0	Q1
SN74HC244APWR	TSSOP	PW	20	2000	330.0	16.4	6.95	7.0	1.4	8.0	16.0	Q1
SN74HC244DBR	SSOP	DB	20	2000	330.0	16.4	8.2	7.5	2.5	12.0	16.0	Q1
SN74HC244DBR	SSOP	DB	20	2000	330.0	16.4	8.2	7.5	2.5	12.0	16.0	Q1
SN74HC244DWR	SOIC	DW	20	2000	330.0	24.4	10.9	13.3	2.7	12.0	24.0	Q1
SN74HC244DWR	SOIC	DW	20	2000	330.0	24.4	10.8	13.3	2.7	12.0	24.0	Q1
SN74HC244DWRG4	SOIC	DW	20	2000	330.0	24.4	10.8	13.3	2.7	12.0	24.0	Q1
SN74HC244NSR	SO	NS	20	2000	330.0	24.4	8.4	13.0	2.5	12.0	24.0	Q1
SN74HC244NSR	SO	NS	20	2000	330.0	24.4	8.4	13.0	2.5	12.0	24.0	Q1
SN74HC244PWR	TSSOP	PW	20	2000	330.0	16.4	6.95	7.0	1.4	8.0	16.0	Q1
SN74HC244PWR	TSSOP	PW	20	2000	330.0	16.4	6.95	7.0	1.4	8.0	16.0	Q1
SN74HC244QDWRG4Q1	SOIC	DW	20	2000	330.0	24.4	10.8	13.3	2.7	12.0	24.0	Q1

TAPE AND REEL BOX DIMENSIONS

*All dimensions are nominal

Device	Package Type	Package Drawing	Pins	SPQ	Length (mm)	Width (mm)	Height (mm)
SN74HC244APWR	TSSOP	PW	20	2000	356.0	356.0	35.0
SN74HC244APWR	TSSOP	PW	20	2000	356.0	356.0	35.0
SN74HC244DBR	SSOP	DB	20	2000	356.0	356.0	35.0
SN74HC244DBR	SSOP	DB	20	2000	356.0	356.0	35.0
SN74HC244DWR	SOIC	DW	20	2000	367.0	367.0	45.0
SN74HC244DWR	SOIC	DW	20	2000	367.0	367.0	45.0
SN74HC244DWRG4	SOIC	DW	20	2000	367.0	367.0	45.0
SN74HC244NSR	SO	NS	20	2000	367.0	367.0	45.0
SN74HC244NSR	SO	NS	20	2000	367.0	367.0	45.0
SN74HC244PWR	TSSOP	PW	20	2000	356.0	356.0	35.0
SN74HC244PWR	TSSOP	PW	20	2000	356.0	356.0	35.0
SN74HC244QDWRG4Q1	SOIC	DW	20	2000	367.0	367.0	45.0

TUBE

*All dimensions are nominal

Device	Package Name	Package Type	Pins	SPQ	L (mm)	W (mm)	T (μm)	B (mm)
5962-8409601VSA	W	CFP	20	25	506.98	26.16	6220	NA
84096012A	FK	LCCC	20	55	506.98	12.06	2030	NA
8409601SA	W	CFP	20	25	506.98	26.16	6220	NA
JM38510/65705B2A	FK	LCCC	20	55	506.98	12.06	2030	NA
JM38510/65705BSA	W	CFP	20	25	506.98	26.16	6220	NA
M38510/65705B2A	FK	LCCC	20	55	506.98	12.06	2030	NA
M38510/65705BSA	W	CFP	20	25	506.98	26.16	6220	NA
SN74HC244N	N	PDIP	20	20	506	13.97	11230	4.32
SN74HC244NE4	N	PDIP	20	20	506	13.97	11230	4.32
SNJ54HC244FK	FK	LCCC	20	55	506.98	12.06	2030	NA
SNJ54HC244W	W	CFP	20	25	506.98	26.16	6220	NA

W (R-GDFP-F20)

CERAMIC DUAL FLATPACK



- NOTES:
- A. All linear dimensions are in inches (millimeters).
 - B. This drawing is subject to change without notice.
 - C. This package can be hermetically sealed with a ceramic lid using glass frit.
 - D. Index point is provided on cap for terminal identification only.
 - E. Falls within Mil-Std 1835 GDFP2-F20



4220206/A 02/2017

NOTES:

1. All linear dimensions are in millimeters. Any dimensions in parenthesis are for reference only. Dimensioning and tolerancing per ASME Y14.5M.
2. This drawing is subject to change without notice.
3. This dimension does not include mold flash, protrusions, or gate burrs. Mold flash, protrusions, or gate burrs shall not exceed 0.15 mm per side.
4. This dimension does not include interlead flash. Interlead flash shall not exceed 0.25 mm per side.
5. Reference JEDEC registration MO-153.

EXAMPLE BOARD LAYOUT

PW0020A

TSSOP - 1.2 mm max height

SMALL OUTLINE PACKAGE



LAND PATTERN EXAMPLE
EXPOSED METAL SHOWN
SCALE: 10X



SOLDER MASK DETAILS

4220206/A 02/2017

NOTES: (continued)

- 6. Publication IPC-7351 may have alternate designs.
- 7. Solder mask tolerances between and around signal pads can vary based on board fabrication site.

EXAMPLE STENCIL DESIGN

PW0020A

TSSOP - 1.2 mm max height

SMALL OUTLINE PACKAGE



SOLDER PASTE EXAMPLE
BASED ON 0.125 mm THICK STENCIL
SCALE: 10X

4220206/A 02/2017

NOTES: (continued)

8. Laser cutting apertures with trapezoidal walls and rounded corners may offer better paste release. IPC-7525 may have alternate design recommendations.
9. Board assembly site may have different recommendations for stencil design.

PW (R-PDSO-G20)

PLASTIC SMALL OUTLINE



- NOTES:
- A. All linear dimensions are in millimeters.
 - B. This drawing is subject to change without notice.
 - C. Publication IPC-7351 is recommended for alternate design.
 - D. Laser cutting apertures with trapezoidal walls and also rounding corners will offer better paste release. Customers should contact their board assembly site for stencil design recommendations. Refer to IPC-7525 for other stencil recommendations.
 - E. Customers should contact their board fabrication site for solder mask tolerances between and around signal pads.

DB0020A



PACKAGE OUTLINE

SSOP - 2 mm max height

SMALL OUTLINE PACKAGE



4214851/B 08/2019

NOTES:

1. All linear dimensions are in millimeters. Any dimensions in parenthesis are for reference only. Dimensioning and tolerancing per ASME Y14.5M.
2. This drawing is subject to change without notice.
3. This dimension does not include mold flash, protrusions, or gate burrs. Mold flash, protrusions, or gate burrs shall not exceed 0.15 mm per side.
4. This dimension does not include interlead flash. Interlead flash shall not exceed 0.25 mm per side.
5. Reference JEDEC registration MO-150.

EXAMPLE BOARD LAYOUT

DB0020A

SSOP - 2 mm max height

SMALL OUTLINE PACKAGE



LAND PATTERN EXAMPLE
EXPOSED METAL SHOWN
SCALE: 10X



4214851/B 08/2019

NOTES: (continued)

- 6. Publication IPC-7351 may have alternate designs.
- 7. Solder mask tolerances between and around signal pads can vary based on board fabrication site.

EXAMPLE STENCIL DESIGN

DB0020A

SSOP - 2 mm max height

SMALL OUTLINE PACKAGE

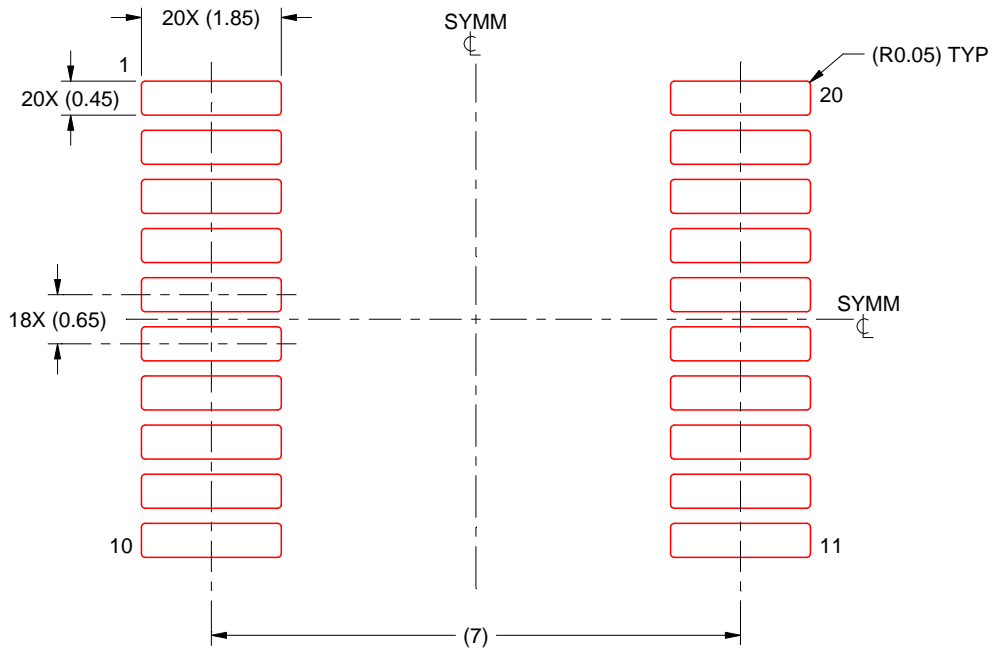

SOLDER PASTE EXAMPLE
BASED ON 0.125 mm THICK STENCIL
SCALE: 10X

4214851/B 08/2019

NOTES: (continued)

8. Laser cutting apertures with trapezoidal walls and rounded corners may offer better paste release. IPC-7525 may have alternate design recommendations.
9. Board assembly site may have different recommendations for stencil design.

MECHANICAL DATA

NS (R-PDSO-G**)

PLASTIC SMALL-OUTLINE PACKAGE

14-PINS SHOWN



- NOTES:
- A. All linear dimensions are in millimeters.
 - B. This drawing is subject to change without notice.
 - C. Body dimensions do not include mold flash or protrusion, not to exceed 0,15.

J (R-GDIP-T**)

14 LEADS SHOWN

CERAMIC DUAL IN-LINE PACKAGE



DIM \ PINS **	14	16	18	20
A	0.300 (7,62) BSC	0.300 (7,62) BSC	0.300 (7,62) BSC	0.300 (7,62) BSC
B MAX	0.785 (19,94)	.840 (21,34)	0.960 (24,38)	1.060 (26,92)
B MIN	—	—	—	—
C MAX	0.300 (7,62)	0.300 (7,62)	0.310 (7,87)	0.300 (7,62)
C MIN	0.245 (6,22)	0.245 (6,22)	0.220 (5,59)	0.245 (6,22)



4040083/F 03/03

- NOTES:
- All linear dimensions are in inches (millimeters).
 - This drawing is subject to change without notice.
 - This package is hermetically sealed with a ceramic lid using glass frit.
 - Index point is provided on cap for terminal identification only on press ceramic glass frit seal only.
 - Falls within MIL STD 1835 GDIP1-T14, GDIP1-T16, GDIP1-T18 and GDIP1-T20.

GENERIC PACKAGE VIEW

FK 20

LCCC - 2.03 mm max height

8.89 x 8.89, 1.27 mm pitch

LEADLESS CERAMIC CHIP CARRIER

This image is a representation of the package family, actual package may vary.
Refer to the product data sheet for package details.



4229370VA\

N (R-PDIP-T**)

PLASTIC DUAL-IN-LINE PACKAGE

16 PINS SHOWN



4040049/E 12/2002

- NOTES:
- A. All linear dimensions are in inches (millimeters).
 - B. This drawing is subject to change without notice.
 - (C) Falls within JEDEC MS-001, except 18 and 20 pin minimum body length (Dim A).
 - (D) The 20 pin end lead shoulder width is a vendor option, either half or full width.

DW0020A



PACKAGE OUTLINE

SOIC - 2.65 mm max height

SOIC

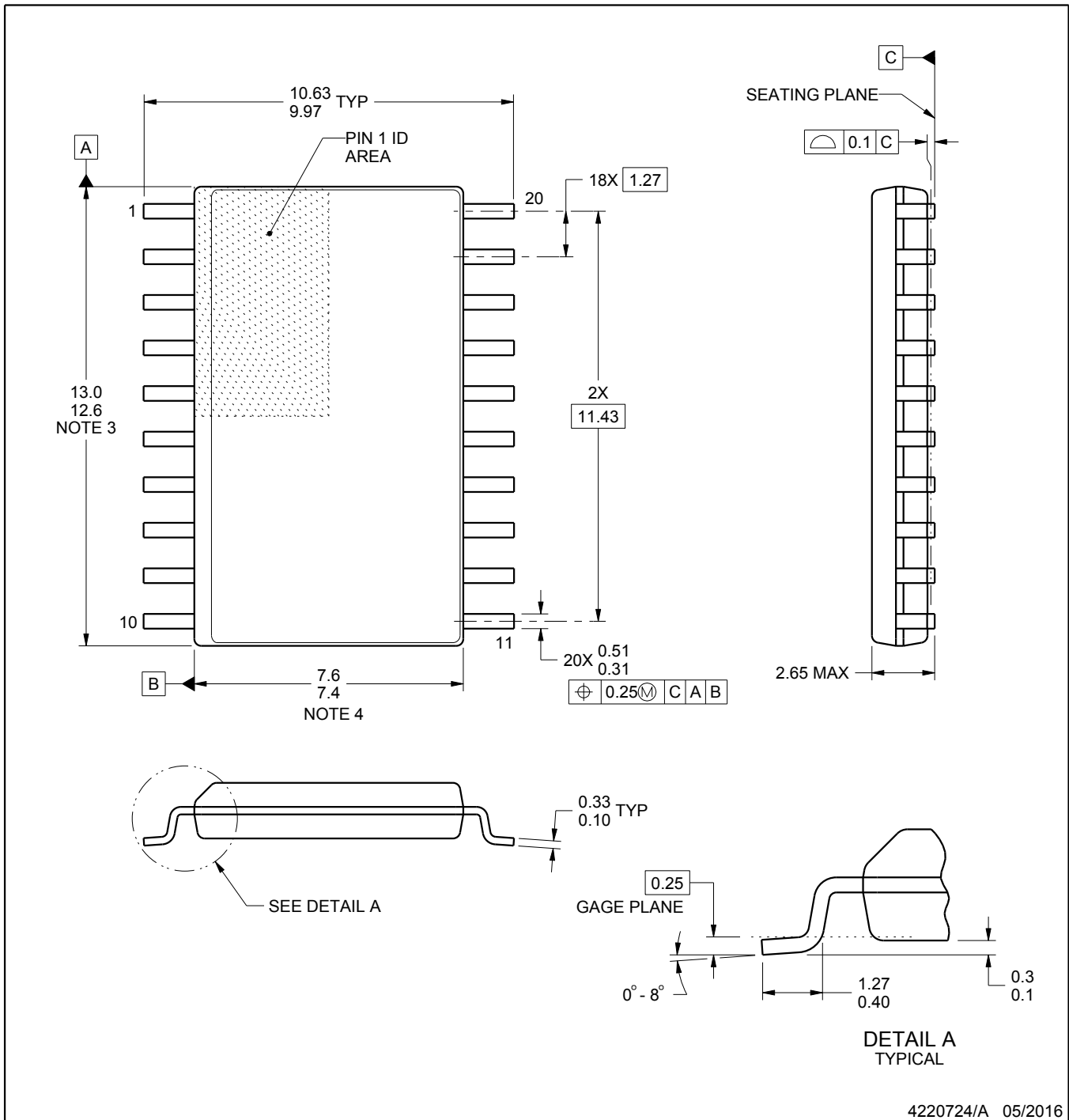

4220724/A 05/2016

NOTES:

1. All linear dimensions are in millimeters. Dimensions in parenthesis are for reference only. Dimensioning and tolerancing per ASME Y14.5M.
2. This drawing is subject to change without notice.
3. This dimension does not include mold flash, protrusions, or gate burrs. Mold flash, protrusions, or gate burrs shall not exceed 0.15 mm per side.
4. This dimension does not include interlead flash. Interlead flash shall not exceed 0.43 mm per side.
5. Reference JEDEC registration MS-013.

EXAMPLE BOARD LAYOUT

DW0020A

SOIC - 2.65 mm max height

SOIC



LAND PATTERN EXAMPLE
SCALE:6X



SOLDER MASK DETAILS

4220724/A 05/2016

NOTES: (continued)

- 6. Publication IPC-7351 may have alternate designs.
- 7. Solder mask tolerances between and around signal pads can vary based on board fabrication site.

EXAMPLE STENCIL DESIGN

DW0020A

SOIC - 2.65 mm max height

SOIC

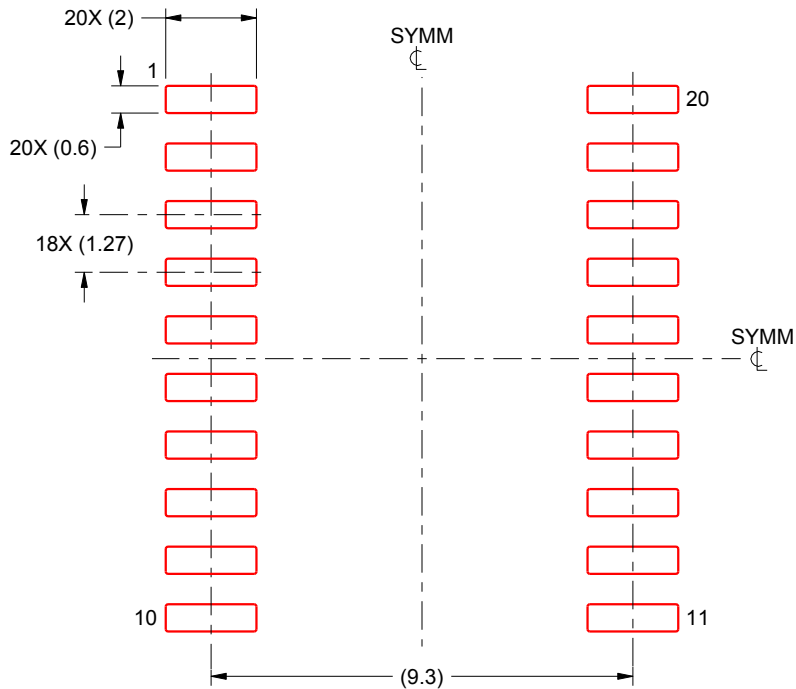

SOLDER PASTE EXAMPLE
BASED ON 0.125 mm THICK STENCIL
SCALE:6X

4220724/A 05/2016

NOTES: (continued)

8. Laser cutting apertures with trapezoidal walls and rounded corners may offer better paste release. IPC-7525 may have alternate design recommendations.
9. Board assembly site may have different recommendations for stencil design.

IMPORTANT NOTICE AND DISCLAIMER

TI PROVIDES TECHNICAL AND RELIABILITY DATA (INCLUDING DATA SHEETS), DESIGN RESOURCES (INCLUDING REFERENCE DESIGNS), APPLICATION OR OTHER DESIGN ADVICE, WEB TOOLS, SAFETY INFORMATION, AND OTHER RESOURCES "AS IS" AND WITH ALL FAULTS, AND DISCLAIMS ALL WARRANTIES, EXPRESS AND IMPLIED, INCLUDING WITHOUT LIMITATION ANY IMPLIED WARRANTIES OF MERCHANTABILITY, FITNESS FOR A PARTICULAR PURPOSE OR NON-INFRINGEMENT OF THIRD PARTY INTELLECTUAL PROPERTY RIGHTS.

These resources are intended for skilled developers designing with TI products. You are solely responsible for (1) selecting the appropriate TI products for your application, (2) designing, validating and testing your application, and (3) ensuring your application meets applicable standards, and any other safety, security, regulatory or other requirements.

These resources are subject to change without notice. TI grants you permission to use these resources only for development of an application that uses the TI products described in the resource. Other reproduction and display of these resources is prohibited. No license is granted to any other TI intellectual property right or to any third party intellectual property right. TI disclaims responsibility for, and you will fully indemnify TI and its representatives against, any claims, damages, costs, losses, and liabilities arising out of your use of these resources.

TI's products are provided subject to [TI's Terms of Sale](#) or other applicable terms available either on [ti.com](https://www.ti.com) or provided in conjunction with such TI products. TI's provision of these resources does not expand or otherwise alter TI's applicable warranties or warranty disclaimers for TI products.

TI objects to and rejects any additional or different terms you may have proposed.

Mailing Address: Texas Instruments, Post Office Box 655303, Dallas, Texas 75265
Copyright © 2024, Texas Instruments Incorporated

Looking for pricing, stock, or lifecycle information?

Click below to explore more details on WIN SOURCE:

 [View SN74HC244DBR on WIN SOURCE](#)

 [Texas Instruments](#) Information

Optimize Your Supply Chain with WIN SOURCE Solutions

-  Global Sourcing Solution
-  Obsolete Management
-  Cost Control Management
-  Shortage Management
-  Alternative Solution
-  Excess Inventory Management