



**THE DATASHEET OF
SN74LS07NSR**



SN74LS07 Hex Buffers and Drivers With Open-Collector High-Voltage Outputs

1 Features

- Convert TTL Voltage Levels to MOS Levels
- High Sink-Current Capability
- Input Clamping Diodes Simplify System Design
- Open-Collector Driver for Indicator Lamps and Relays

2 Applications

- AV Receivers
- Audio Docks: Portable
- Blu-ray Players and Home Theaters
- MP3 Players or Recorders
- Personal Digital Assistants (PDA)
- Power: Telecom/Server AC/DC Supply: Single Controller: Analog and Digital
- Solid-State Drives (SSD): Client and Enterprise
- TVs: LCD, Digital, and High-Definition (HDTV)
- Tablets: Enterprise
- Video Analytics: Server
- Wireless Headsets, Keyboards, and Mice

3 Description

These hex buffers and drivers feature high-voltage open-collector outputs to interface with high-level circuits or for driving high-current loads. They are also characterized for use as buffers for driving TTL inputs. The SN74LS07 devices have a rated output voltage of 30 V. The maximum sink current is 40 mA.

These circuits are compatible with most TTL families. Inputs are diode-clamped to minimize transmission-line effects, which simplifies design. Typical power dissipation is 140 mW, and average propagation delay time is 12 ns.

Device Information⁽¹⁾

PART NUMBER	PACKAGE (PINS)	BODY SIZE (NOM)
SN74LS07D	SOIC (14)	8.65 mm × 3.90 mm
SN74LS07DB	SSOP (14)	6.20 mm × 5.30 mm
SN74LS07N	PDIP (14)	19.30 mm × 6.35 mm
SN74LS07NS	SO (14)	10.30 mm × 5.30 mm

(1) For all available packages, see the orderable addendum at the end of the data sheet.

Logic Diagram (Positive Logic)

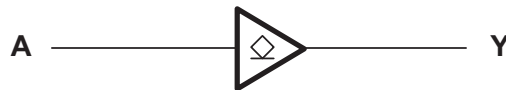

Copyright © 2016 Texas Instruments Incorporated



Table of Contents

1 Features 1 2 Applications 1 3 Description 1 4 Revision History 2 5 Pin Configuration and Functions 3 6 Specifications 4 6.1 Absolute Maximum Ratings 4 6.2 ESD Ratings..... 4 6.3 Recommended Operating Conditions..... 4 6.4 Thermal Information 4 6.5 Electrical Characteristics..... 5 6.6 Switching Characteristics 5 6.7 Typical Characteristics 5 7 Parameter Measurement Information 6 8 Detailed Description 7 8.1 Overview 7 8.2 Functional Block Diagram 7	8.3 Feature Description..... 7 8.4 Device Functional Modes..... 7 9 Application and Implementation 8 9.1 Application Information..... 8 9.2 Typical Application 8 10 Power Supply Recommendations 9 11 Layout 10 11.1 Layout Guidelines 10 11.2 Layout Example 10 12 Device and Documentation Support 11 12.1 Documentation Support 11 12.2 Community Resource..... 11 12.3 Trademarks 11 12.4 Electrostatic Discharge Caution..... 11 12.5 Glossary 11 13 Mechanical, Packaging, and Orderable Information 11
--	--

4 Revision History

NOTE: Page numbers for previous revisions may differ from page numbers in the current version.

Changes from Revision C (February 2004) to Revision D	Page
• Added <i>Device Information</i> table, <i>ESD Ratings</i> table, <i>Feature Description</i> section, <i>Device Functional Modes</i> , <i>Application and Implementation</i> section, <i>Power Supply Recommendations</i> section, <i>Layout</i> section, <i>Device and Documentation Support</i> section, and <i>Mechanical, Packaging, and Orderable Information</i> section	1
• Deleted SN54LS07 and SN74LS17 from the data sheet because they are obsolete and no longer supplied.....	1
• Deleted <i>Ordering Information</i> table.	1

5 Pin Configuration and Functions

D, DB, N, or NS Packages
14-Pin SOIC, SSOP, PDIP, SO
Top View

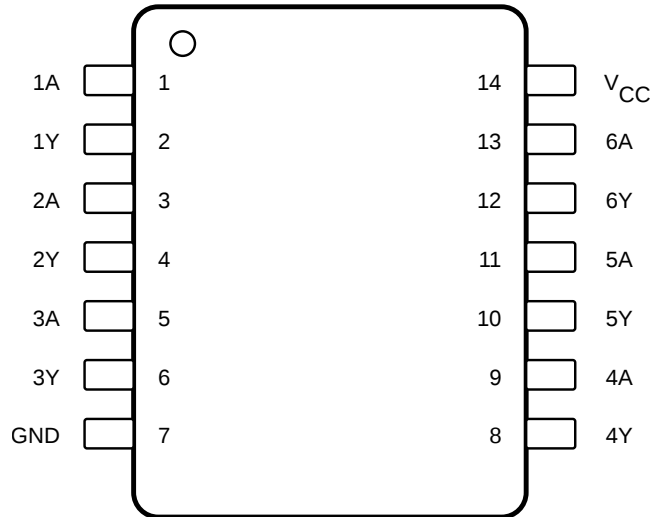

Pin Functions

PIN		I/O	DESCRIPTION
NO.	NAME		
1	1A	I	Input 1
2	1Y	O	Output 1
3	2A	I	Input 2
4	2Y	O	Output 2
5	3A	I	Input 3
6	3Y	O	Output 3
7	GND	—	Ground pin
8	4Y	O	Output 4
9	4A	I	Input 4
10	5Y	O	Output 5
11	5A	I	Input 5
12	6Y	O	Output 6
13	6A	I	Input 6
14	V _{CC}	—	Power pin

6 Specifications

6.1 Absolute Maximum Ratings

over operating free-air temperature range (unless otherwise noted)⁽¹⁾

		MIN	MAX	UNIT
V _{CC}	Supply voltage		7	V
V _I	Input voltage ⁽²⁾		7	V
V _O	Output voltage ⁽²⁾⁽³⁾		30	V
T _J	Operating virtual junction temperature		150	°C
T _{stg}	Storage temperature	-65	150	°C

- (1) Stresses beyond those listed under *Absolute Maximum Ratings* may cause permanent damage to the device. These are stress ratings only, which do not imply functional operation of the device at these or any other conditions beyond those indicated under *Recommended Operating Conditions*. Exposure to absolute-maximum-rated conditions for extended periods may affect device reliability.
- (2) All voltage values are with respect to GND.
- (3) This is the maximum voltage that should be applied to any output when it is in the off state.

6.2 ESD Ratings

			VALUE	UNIT
V _(ESD)	Electrostatic discharge	Human-body model (HBM), per ANSI/ESDA/JEDEC JS-001 ⁽¹⁾	±2000	V
		Charged-device model (CDM), per JEDEC specification JESD22-C101 ⁽²⁾	±1000	

- (1) JEDEC document JEP155 states that 500-V HBM allows safe manufacturing with a standard ESD control process.
- (2) JEDEC document JEP157 states that 250-V CDM allows safe manufacturing with a standard ESD control process.

6.3 Recommended Operating Conditions

over operating free-air temperature range (unless otherwise noted)⁽¹⁾

		MIN	NOM	MAX	UNIT
V _{CC}	Supply voltage	4.75	5	5.25	V
V _{IH}	High-level input voltage	2			V
V _{IL}	Low-level input voltage			0.8	V
V _{OH}	High-level output voltage			30	V
I _{OL}	Low-level output current			40	mA
T _A	Operating free-air temperature	0		70	°C

- (1) All unused inputs of the device must be held at V_{CC} or GND to ensure proper device operation. See the TI application report, *Implications of Slow or Floating CMOS Inputs*, [SCBA004](#).

6.4 Thermal Information

THERMAL METRIC ⁽¹⁾	SN74LS07				UNIT	
	D (SOIC)	DB (SSOP)	N (PDIP)	NS (SO)		
	14 PINS	14 PINS	14 PINS	14 PINS		
R _{θJA}	Junction-to-ambient thermal resistance	85.2	97.4	50.2	82.8	°C/W
R _{θJC(top)}	Junction-to-case (top) thermal resistance	43.5	49.8	37.5	40.9	°C/W
R _{θJB}	Junction-to-board thermal resistance	39.7	44.5	30	41.4	°C/W
ψ _{JT}	Junction-to-top characterization parameter	10.9	16.5	22.3	12.4	°C/W
ψ _{JB}	Junction-to-board characterization parameter	39.4	44	29.9	41.1	°C/W

- (1) For more information about traditional and new thermal metrics, see the *Semiconductor and IC Package Thermal Metrics* application report, [SPRA953](#).

6.5 Electrical Characteristics

over recommended operating free-air temperature range (unless otherwise noted)

PARAMETER	TEST CONDITIONS ⁽¹⁾	MIN	TYP	MAX	UNIT
V_{IK}	$V_{CC} = \text{MIN}, I_I = -12 \text{ mA}$			-1.5	V
I_{OH}	$V_{CC} = \text{MIN}, V_{IH} = 2 \text{ V}$	$V_{OH} = 30 \text{ V}$		0.25	mA
V_{OL}	$V_{CC} = \text{MIN}, V_{IL} = 0.8 \text{ V}$	$I_{OL} = 16 \text{ mA}$		0.4	V
		$I_{OL} = \text{MAX}^{(2)}$		0.7	
I_I	$V_{CC} = \text{MAX}, V_I = 7 \text{ V}$			1	mA
I_{IH}	$V_{CC} = \text{MAX}, V_I = 2.4 \text{ V}$			20	μA
I_{IL}	$V_{CC} = \text{MAX}, V_I = 0.4 \text{ V}$			-0.2	mA
I_{CCH}	$V_{CC} = \text{MAX}$			14	mA
I_{CCL}	$V_{CC} = \text{MAX}$			45	mA

(1) For conditions shown as MIN or MAX, use the appropriate value specified under recommended operating conditions.

(2) $I_{OL} = 40 \text{ mA}$

6.6 Switching Characteristics

$V_{CC} = 5 \text{ V}, T_A = 25^\circ\text{C}$ (see [Figure 2](#))

PARAMETER	FROM (INPUT)	TO (OUTPUT)	TEST CONDITIONS	MIN	TYP	MAX	UNIT
t_{PLH}	A	Y	$R_L = 110 \Omega, C_L = 15 \text{ pF}$		6	10	ns
t_{PHL}					19	30	

6.7 Typical Characteristics

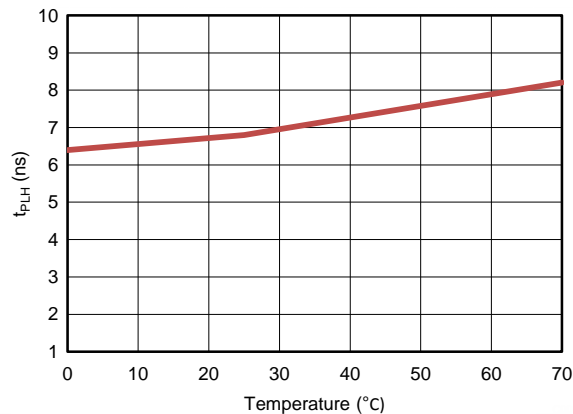
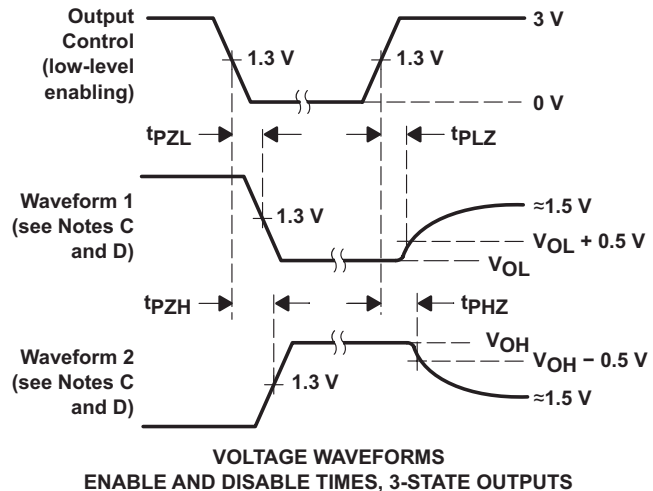
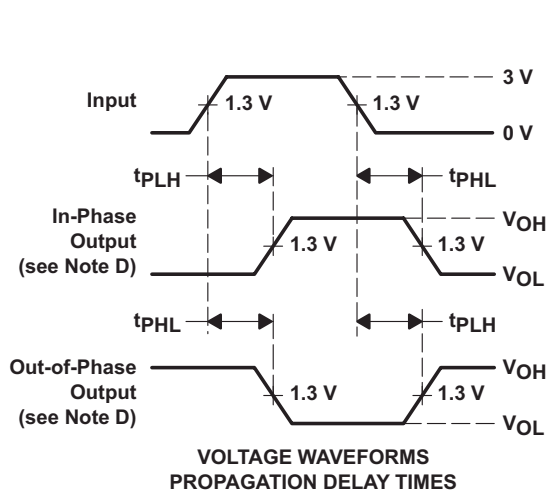
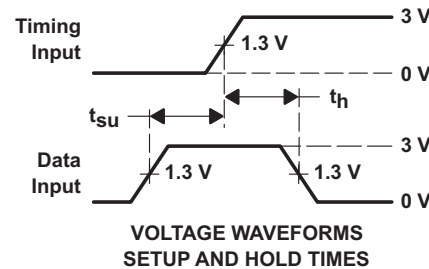
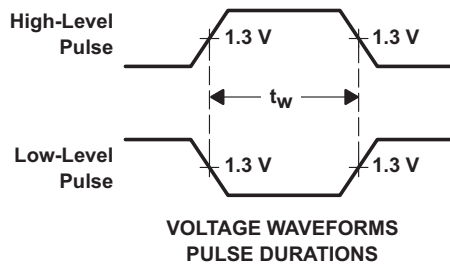
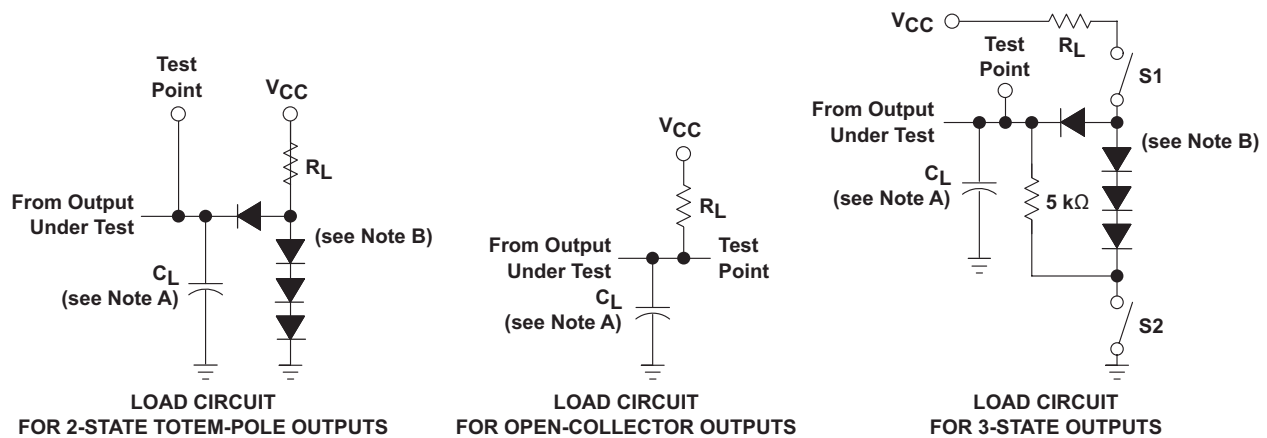

Figure 1. t_{PLH} vs. Temperature

7 Parameter Measurement Information



- C_L includes probe and jig capacitance.
- All diodes are 1N3064 or equivalent.
- Waveform 1 is for an output with internal conditions such that the output is low, except when disabled by the output control. Waveform 2 is for an output with internal conditions such that the output is high, except when disabled by the output control.
- S_1 and S_2 are closed for t_{PLH} , t_{PHL} , t_{PHZ} , and t_{PLZ} ; S_1 is open and S_2 is closed for t_{PZH} ; S_1 is closed and S_2 is open for t_{PZL} .
- Phase relationships between inputs and outputs have been chosen arbitrarily for these examples.
- All input pulses are supplied by generators having the following characteristics: $PRR \leq 1$ MHz, $Z_O \approx 50 \Omega$, $t_r \leq 1.5$ ns, $t_f \leq 2.6$ ns.
- The outputs are measured one at a time, with one input transition per measurement.

Figure 2. Load Circuits and Voltage Waveforms

8 Detailed Description

8.1 Overview

The outputs of the SN74LS07 device are open-collector and can be connected to other open-collector outputs to implement active-low wired-OR or active-high wired-AND functions. The maximum sink current for the SN74LS07 is 40 mA.

Inputs can be driven from 2.5-V, 3.3-V (LVTTL), or 5-V (CMOS) devices. This feature allows the use of this device as translators in a mixed-system environment.

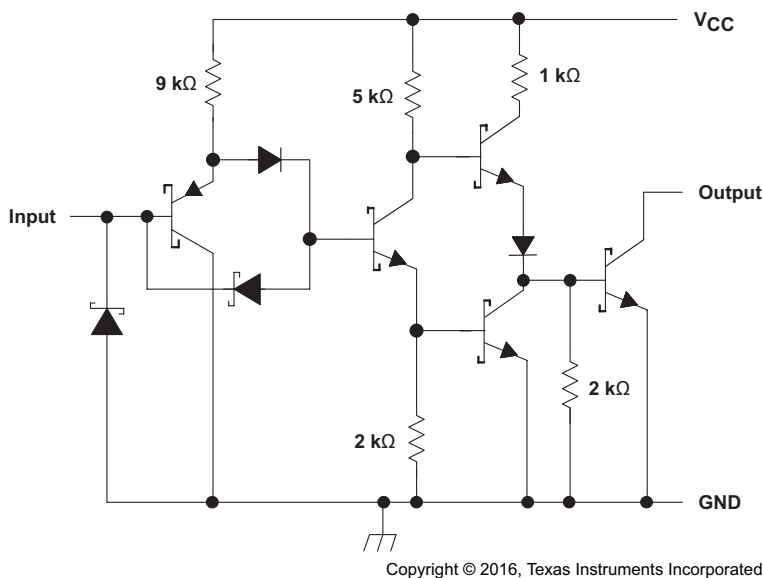

Copyright © 2016, Texas Instruments Incorporated

Resistor values shown are nominal.

Figure 3. Schematic (Gate)

8.2 Functional Block Diagram



Copyright © 2016 Texas Instruments Incorporated

8.3 Feature Description

- Allows for up translation
 - Inputs accept voltages to 5.25 V
 - Outputs accept voltages to 30 V
- High Sink-Current Capability
 - Up to 40 mA

8.4 Device Functional Modes

Table 1 lists the functions of this device.

Table 1. Function Table

INPUT A	OUTPUT Y
H	Hi-Z
L	L

9 Application and Implementation

NOTE

Information in the following applications sections is not part of the TI component specification, and TI does not warrant its accuracy or completeness. TI's customers are responsible for determining suitability of components for their purposes. Customers should validate and test their design implementation to confirm system functionality.

9.1 Application Information

The SN74LS07 device is a high-drive, open-drain CMOS device that can be used for a multitude of buffer-type functions. It can produce 40 mA of drive current at 5 V. Therefore, this device is ideal for driving multiple inputs. The inputs are 5.25-V tolerant and outputs are 30-V tolerant.

9.2 Typical Application

Multiple channels of the SN74LS07 device can be used to create a positive AND logic function, as shown in [Figure 4](#). Additionally, the SN74LS07 device can be used to drive an LED by sinking up to 40 mA, which may be more than the previous stage can sink.

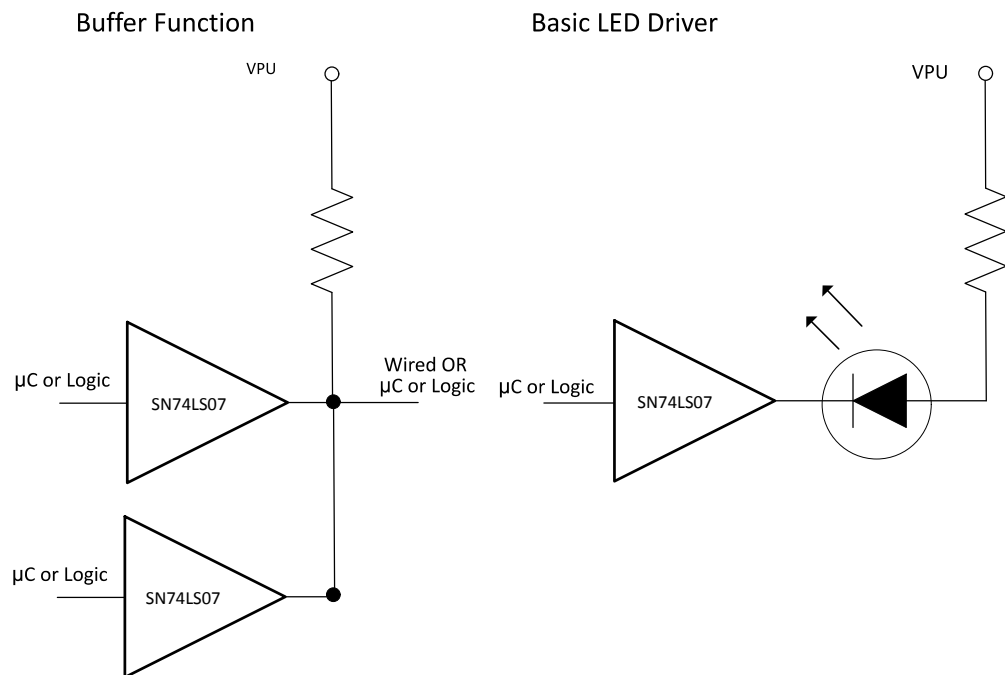

Copyright © 2016, Texas Instruments Incorporated

Figure 4. Typical Application Diagram

9.2.1 Design Requirements

Ensure that the inputs are in a known state as defined by V_{IH} and V_{IL} noted in [Recommended Operating Conditions](#), or else the outputs may be in an unknown state.

9.2.2 Detailed Design Procedure

1. Recommended Input Conditions
 - For specified high and low level, see V_{IH} and V_{IL} in [Recommended Operating Conditions](#).
 - Inputs are overvoltage tolerant allowing them to go as high as 5.25 V.
2. Recommend Output Conditions
 - Load currents must not exceed 40 mA per output.
 - Outputs must not be pulled above 30 V.

Typical Application (continued)

9.2.3 Application Curve

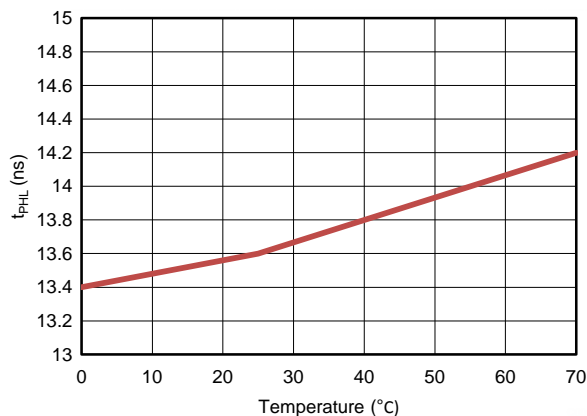

Figure 5. t_{PHL} vs Temperature

10 Power Supply Recommendations

The power supply can be any voltage between the minimum and maximum supply voltage rating indicated in [Recommended Operating Conditions](#).

Each V_{CC} pin must have a good bypass capacitor to prevent power disturbance. For devices with a single supply, TI recommends a 0.1-μF capacitor; if there are multiple V_{CC} pins, then TI recommends either a 0.01-μF or 0.022-μF capacitor for each power pin. It is acceptable to parallel multiple bypass capacitors to reject different frequencies of noise. A 0.1-μF and a 1-μF capacitor are commonly used in parallel. The bypass capacitor must be installed as close to the power pin as possible for best results.

11 Layout

11.1 Layout Guidelines

When using multiple bit logic devices, inputs must never float.

In many cases, functions or parts of functions of digital logic devices are unused, for example, when only two inputs of a triple-input AND gate are used or only 3 of the 4 buffer gates are used. Such input pins must not be left unconnected because the undefined voltages at the outside connections result in undefined operational states. Figure 6 specifies the rules that must be observed under all circumstances. All unused inputs of digital logic devices must be connected to a high or low bias to prevent them from floating. The logic level that must be applied to any particular unused input depends on the function of the device. Generally they are tied to GND or V_{CC} , whichever makes more sense or is more convenient. It is generally acceptable to float outputs, unless the part is a transceiver.

11.2 Layout Example

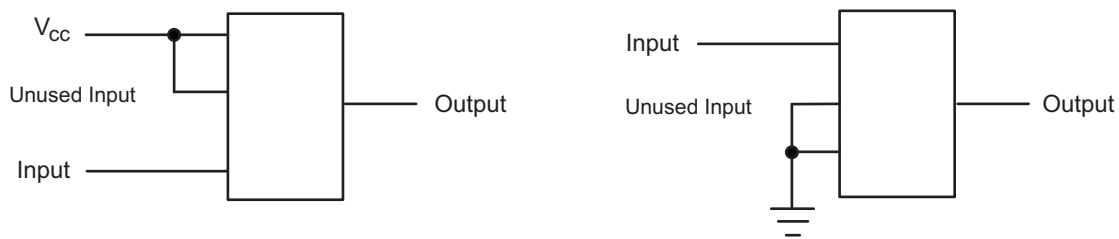

Figure 6. Layout Diagram

12 Device and Documentation Support

12.1 Documentation Support

12.1.1 Related Documentation

For related documentation see the followign:

Implications of Slow or Floating CMOS Inputs, [SCBA004](#)

12.2 Community Resource

The following links connect to TI community resources. Linked contents are provided "AS IS" by the respective contributors. They do not constitute TI specifications and do not necessarily reflect TI's views; see TI's [Terms of Use](#).

TI E2E™ Online Community *TI's Engineer-to-Engineer (E2E) Community*. Created to foster collaboration among engineers. At [e2e.ti.com](#), you can ask questions, share knowledge, explore ideas and help solve problems with fellow engineers.

Design Support *TI's Design Support* Quickly find helpful E2E forums along with design support tools and contact information for technical support.

12.3 Trademarks

E2E is a trademark of Texas Instruments.
All other trademarks are the property of their respective owners.

12.4 Electrostatic Discharge Caution



These devices have limited built-in ESD protection. The leads should be shorted together or the device placed in conductive foam during storage or handling to prevent electrostatic damage to the MOS gates.

12.5 Glossary

[SLYZ022](#) — *TI Glossary*.

This glossary lists and explains terms, acronyms, and definitions.

13 Mechanical, Packaging, and Orderable Information

The following pages include mechanical, packaging, and orderable information. This information is the most current data available for the designated devices. This data is subject to change without notice and revision of this document. For browser-based versions of this data sheet, refer to the left-hand navigation.

PACKAGING INFORMATION

Orderable Device	Status (1)	Package Type	Package Drawing	Pins	Package Qty	Eco Plan (2)	Lead/Ball Finish (6)	MSL Peak Temp (3)	Op Temp (°C)	Device Marking (4/5)	Samples
SN74LS07D	ACTIVE	SOIC	D	14	50	Green (RoHS & no Sb/Br)	CU NIPDAU	Level-1-260C-UNLIM	0 to 70	LS07	Samples
SN74LS07DBR	ACTIVE	SSOP	DB	14	2000	Green (RoHS & no Sb/Br)	CU NIPDAU	Level-1-260C-UNLIM	0 to 70	LS07	Samples
SN74LS07DBRG4	ACTIVE	SSOP	DB	14	2000	Green (RoHS & no Sb/Br)	CU NIPDAU	Level-1-260C-UNLIM	0 to 70	LS07	Samples
SN74LS07DR	ACTIVE	SOIC	D	14	2500	Green (RoHS & no Sb/Br)	CU NIPDAU	Level-1-260C-UNLIM	0 to 70	LS07	Samples
SN74LS07DRE4	ACTIVE	SOIC	D	14	2500	Green (RoHS & no Sb/Br)	CU NIPDAU	Level-1-260C-UNLIM	0 to 70	LS07	Samples
SN74LS07N	ACTIVE	PDIP	N	14	25	Green (RoHS & no Sb/Br)	CU NIPDAU	N / A for Pkg Type	0 to 70	SN74LS07N	Samples
SN74LS07NSR	ACTIVE	SO	NS	14	2000	Green (RoHS & no Sb/Br)	CU NIPDAU	Level-1-260C-UNLIM	0 to 70	74LS07	Samples
SN74LS07NSRG4	ACTIVE	SO	NS	14	2000	Green (RoHS & no Sb/Br)	CU NIPDAU	Level-1-260C-UNLIM	0 to 70	74LS07	Samples

(1) The marketing status values are defined as follows:

ACTIVE: Product device recommended for new designs.

LIFEBUY: TI has announced that the device will be discontinued, and a lifetime-buy period is in effect.

NRND: Not recommended for new designs. Device is in production to support existing customers, but TI does not recommend using this part in a new design.

PREVIEW: Device has been announced but is not in production. Samples may or may not be available.

OBSELETE: TI has discontinued the production of the device.

(2) **RoHS:** TI defines "RoHS" to mean semiconductor products that are compliant with the current EU RoHS requirements for all 10 RoHS substances, including the requirement that RoHS substance do not exceed 0.1% by weight in homogeneous materials. Where designed to be soldered at high temperatures, "RoHS" products are suitable for use in specified lead-free processes. TI may reference these types of products as "Pb-Free".

RoHS Exempt: TI defines "RoHS Exempt" to mean products that contain lead but are compliant with EU RoHS pursuant to a specific EU RoHS exemption.

Green: TI defines "Green" to mean the content of Chlorine (Cl) and Bromine (Br) based flame retardants meet JS709B low halogen requirements of <=1000ppm threshold. Antimony trioxide based flame retardants must also meet the <=1000ppm threshold requirement.

(3) MSL, Peak Temp. - The Moisture Sensitivity Level rating according to the JEDEC industry standard classifications, and peak solder temperature.

(4) There may be additional marking, which relates to the logo, the lot trace code information, or the environmental category on the device.

⁽⁵⁾ Multiple Device Markings will be inside parentheses. Only one Device Marking contained in parentheses and separated by a "-" will appear on a device. If a line is indented then it is a continuation of the previous line and the two combined represent the entire Device Marking for that device.

⁽⁶⁾ Lead/Ball Finish - Orderable Devices may have multiple material finish options. Finish options are separated by a vertical ruled line. Lead/Ball Finish values may wrap to two lines if the finish value exceeds the maximum column width.

Important Information and Disclaimer:The information provided on this page represents TI's knowledge and belief as of the date that it is provided. TI bases its knowledge and belief on information provided by third parties, and makes no representation or warranty as to the accuracy of such information. Efforts are underway to better integrate information from third parties. TI has taken and continues to take reasonable steps to provide representative and accurate information but may not have conducted destructive testing or chemical analysis on incoming materials and chemicals. TI and TI suppliers consider certain information to be proprietary, and thus CAS numbers and other limited information may not be available for release.

In no event shall TI's liability arising out of such information exceed the total purchase price of the TI part(s) at issue in this document sold by TI to Customer on an annual basis.

TAPE AND REEL INFORMATION



QUADRANT ASSIGNMENTS FOR PIN 1 ORIENTATION IN TAPE



*All dimensions are nominal

Device	Package Type	Package Drawing	Pins	SPQ	Reel Diameter (mm)	Reel Width W1 (mm)	A0 (mm)	B0 (mm)	K0 (mm)	P1 (mm)	W (mm)	Pin1 Quadrant
SN74LS07DR	SOIC	D	14	2500	330.0	16.4	6.5	9.0	2.1	8.0	16.0	Q1

TAPE AND REEL BOX DIMENSIONS



*All dimensions are nominal

Device	Package Type	Package Drawing	Pins	SPQ	Length (mm)	Width (mm)	Height (mm)
SN74LS07DR	SOIC	D	14	2500	367.0	367.0	38.0

MECHANICAL DATA

NS (R-PDSO-G**)

PLASTIC SMALL-OUTLINE PACKAGE

14-PINS SHOWN



- NOTES:
- A. All linear dimensions are in millimeters.
 - B. This drawing is subject to change without notice.
 - C. Body dimensions do not include mold flash or protrusion, not to exceed 0,15.

D (R-PDSO-G14)

PLASTIC SMALL OUTLINE



- NOTES:
- All linear dimensions are in millimeters.
 - This drawing is subject to change without notice.
 - Publication IPC-7351 is recommended for alternate designs.
 - Laser cutting apertures with trapezoidal walls and also rounding corners will offer better paste release. Customers should contact their board assembly site for stencil design recommendations. Refer to IPC-7525 for other stencil recommendations.
 - Customers should contact their board fabrication site for solder mask tolerances between and around signal pads.

N (R-PDIP-T**)

PLASTIC DUAL-IN-LINE PACKAGE

16 PINS SHOWN



- NOTES:
- A. All linear dimensions are in inches (millimeters).
 - B. This drawing is subject to change without notice.
 - $\triangle C$ Falls within JEDEC MS-001, except 18 and 20 pin minimum body length (Dim A).
 - $\triangle D$ The 20 pin end lead shoulder width is a vendor option, either half or full width.

4040049/E 12/2002

IMPORTANT NOTICE AND DISCLAIMER

TI PROVIDES TECHNICAL AND RELIABILITY DATA (INCLUDING DATASHEETS), DESIGN RESOURCES (INCLUDING REFERENCE DESIGNS), APPLICATION OR OTHER DESIGN ADVICE, WEB TOOLS, SAFETY INFORMATION, AND OTHER RESOURCES "AS IS" AND WITH ALL FAULTS, AND DISCLAIMS ALL WARRANTIES, EXPRESS AND IMPLIED, INCLUDING WITHOUT LIMITATION ANY IMPLIED WARRANTIES OF MERCHANTABILITY, FITNESS FOR A PARTICULAR PURPOSE OR NON-INFRINGEMENT OF THIRD PARTY INTELLECTUAL PROPERTY RIGHTS.

These resources are intended for skilled developers designing with TI products. You are solely responsible for (1) selecting the appropriate TI products for your application, (2) designing, validating and testing your application, and (3) ensuring your application meets applicable standards, and any other safety, security, or other requirements. These resources are subject to change without notice. TI grants you permission to use these resources only for development of an application that uses the TI products described in the resource. Other reproduction and display of these resources is prohibited. No license is granted to any other TI intellectual property right or to any third party intellectual property right. TI disclaims responsibility for, and you will fully indemnify TI and its representatives against, any claims, damages, costs, losses, and liabilities arising out of your use of these resources.

TI's products are provided subject to TI's Terms of Sale (www.ti.com/legal/termsofsale.html) or other applicable terms available either on ti.com or provided in conjunction with such TI products. TI's provision of these resources does not expand or otherwise alter TI's applicable warranties or warranty disclaimers for TI products.

Mailing Address: Texas Instruments, Post Office Box 655303, Dallas, Texas 75265
Copyright © 2019, Texas Instruments Incorporated

Looking for pricing, stock, or lifecycle information?

Click below to explore more details on WIN SOURCE:

 [View SN74LS07NSR on WIN SOURCE](#)

 [Texas Instruments](#) Information

Optimize Your Supply Chain with WIN SOURCE Solutions

-  Global Sourcing Solution
-  Obsolete Management
-  Cost Control Management
-  Shortage Management
-  Alternative Solution
-  Excess Inventory Management