



**THE DATASHEET OF  
SN74LVC07APWRG4**



## SN74LVC07A Hex Buffer and Driver With Open-Drain Outputs

### 1 Features

- Operates From 1.65 V to 5 V
- Inputs and Open-Drain Outputs Accept Voltages Up to 5.5 V
- Max  $t_{pd}$  of 2.6 ns at 5 V
- Latch-Up Performance Exceeds 250 mA Per JESD 17
- $I_{off}$  Supports Live Insertion, Partial-Power-Down Mode, and Back-Drive Protection

### 2 Applications

- AV Receiver
- Audio Dock: Portable
- Blu-ray Player and Home Theater
- MP3 Player or Recorder
- Personal Digital Assistant (PDA)
- Power: Telecom/Server AC/DC Supply: Single Controller: Analog and Digital
- Solid State Drive (SSD): Client and Enterprise
- TV: LCD, Digital, and High-Definition (HDTV)
- Tablet: Enterprise
- Video Analytics: Server
- Wireless Headset, Keyboard, and Mouse

### 3 Description

The SN74LVC07A device is a hex buffer and driver that is designed for 1.65-V to 5.5-V  $V_{CC}$  operation.

#### Device Information<sup>(1)</sup>

PART NUMBER	PACKAGE	BODY SIZE (NOM)
SN74LVC07AD	SOIC (14)	8.65 mm × 3.91 mm
SN74LVC07ADB	SSOP (14)	6.20 mm × 5.30 mm
SN74LVC07ADGV	TVSOP (14)	3.60 mm × 4.40 mm
SN74LVC07APW	TSSOP (14)	5.00 mm × 4.40 mm
SN74LVC07ANS	SO (14)	10.30 mm × 5.30 mm
SN74LVC07ARGY	VQFN (14)	3.50 mm × 3.50 mm

(1) For all available packages, see the orderable addendum at the end of the data sheet.

#### Simplified Schematic



Copyright © 2016 Texas Instruments Incorporated



## Table of Contents

<b>1 Features</b> .....	<b>1</b>	8.1 Overview .....	<b>12</b>
<b>2 Applications</b> .....	<b>1</b>	8.2 Functional Block Diagram .....	<b>12</b>
<b>3 Description</b> .....	<b>1</b>	8.3 Feature Description .....	<b>12</b>
<b>4 Revision History</b> .....	<b>2</b>	8.4 Device Functional Modes .....	<b>12</b>
<b>5 Pin Configuration and Functions</b> .....	<b>4</b>	<b>9 Application and Implementation</b> .....	<b>13</b>
<b>6 Specifications</b> .....	<b>5</b>	9.1 Application Information .....	<b>13</b>
6.1 Absolute Maximum Ratings .....	<b>5</b>	9.2 Typical Application .....	<b>13</b>
6.2 ESD Ratings .....	<b>5</b>	<b>10 Power Supply Recommendations</b> .....	<b>14</b>
6.3 Recommended Operating Conditions .....	<b>5</b>	<b>11 Layout</b> .....	<b>14</b>
6.4 Thermal Information .....	<b>6</b>	11.1 Layout Guidelines .....	<b>14</b>
6.5 Electrical Characteristics—DC Limit Changes .....	<b>6</b>	11.2 Layout Example .....	<b>15</b>
6.6 Switching Characteristics .....	<b>6</b>	<b>12 Device and Documentation Support</b> .....	<b>16</b>
6.7 Operating Characteristics .....	<b>7</b>	12.1 Documentation Support .....	<b>16</b>
6.8 Typical Characteristics .....	<b>7</b>	12.2 Receiving Notification of Documentation Updates .....	<b>16</b>
<b>7 Parameter Measurement Information</b> .....	<b>8</b>	12.3 Community Resources .....	<b>16</b>
7.1 $V_{CC} = 1.8\text{ V} \pm 0.15\text{ V}$ .....	<b>8</b>	12.4 Trademarks .....	<b>16</b>
7.2 $V_{CC} = 2.5\text{ V} \pm 0.2\text{ V}$ .....	<b>9</b>	12.5 Electrostatic Discharge Caution .....	<b>16</b>
7.3 $V_{CC} = 2.7\text{ and }3.3\text{ V} \pm 0.3\text{ V}$ .....	<b>10</b>	12.6 Glossary .....	<b>16</b>
7.4 $V_{CC} = 5\text{ V} \pm 0.5\text{ V}$ .....	<b>11</b>	<b>13 Mechanical, Packaging, and Orderable Information</b> .....	<b>16</b>
<b>8 Detailed Description</b> .....	<b>12</b>		

## 4 Revision History

NOTE: Page numbers for previous revisions may differ from page numbers in the current version.

<b>Changes from Revision V (May 2015) to Revision W</b>	<b>Page</b>
• Changed <i>Pin Functions</i> table .....	<b>4</b>
• Added Junction temperature to the <i>Absolute Maximum Ratings</i> table .....	<b>5</b>
• Reformatted the <i>Electrical Characteristics</i> and the <i>Switching Characteristics</i> tables .....	<b>6</b>
• Changed <i>Typical Application Diagram</i> .....	<b>13</b>
• Added <i>Receiving Notification of Documentation Updates</i> section .....	<b>16</b>

<b>Changes from Revision U (June 2014) to Revision V</b>	<b>Page</b>
• Changed <i>Handling Ratings</i> table to <i>ESD Ratings</i> table .....	<b>5</b>
• Added industry standard terms to package designators in the <i>Thermal Information</i> table .....	<b>6</b>
• Changed from "High" to "High-Z" in the <i>Function Table</i> .....	<b>12</b>

<b>Changes from Revision T (February 2011) to Revision U</b>	<b>Page</b>
• Updated document to new TI data sheet format .....	<b>1</b>
• Removed <i>Ordering Information</i> table .....	<b>1</b>
• Added <i>Applications</i> .....	<b>1</b>
• Added $I_{off}$ <i>Features</i> bullet .....	<b>1</b>
• Added <i>Device Information</i> table .....	<b>1</b>
• Added <i>Handling Ratings</i> table .....	<b>5</b>
• Changed MAX operating free-air temperature from 85°C to 125°C .....	<b>5</b>
• Updated <i>Thermal Information</i> table .....	<b>6</b>
• Added –40°C TO +125°C temperature range to <i>Electrical Characteristics</i> table .....	<b>6</b>
• Added <i>Switching Characteristics</i> table for –40°C TO 125°C temperature range .....	<b>6</b>

---

- Added *Typical Characteristics* ..... [7](#)

---

## 5 Pin Configuration and Functions

**D, DB, DGV, NS, PW Package**  
**14-Pin SOIC, SSOP, TVSOP, SO, TSSOP**  
**Top View**

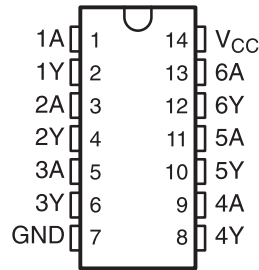

**RGY Package**  
**14-Pin VQFN**  
**Top View**

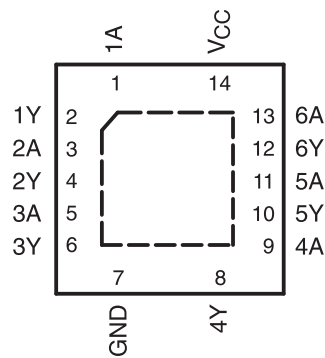

### Pin Functions

PIN		I/O	DESCRIPTION
NO.	NAME		
1	1A	I	Input 1
2	1Y	O	Output 1
3	2A	I	Input 2
4	2Y	O	Output 2
5	3A	I	Input 3
6	3Y	O	Output 3
7	GND	—	Ground pin
8	4Y	O	Output 4
9	4A	I	Input 4
10	5Y	O	Output 5
11	5A	I	Input 5
12	6Y	O	Output 6
13	6A	I	Input 6
14	V <sub>CC</sub>	—	Power pin

## 6 Specifications

### 6.1 Absolute Maximum Ratings

over operating free-air temperature range (unless otherwise noted)<sup>(1)</sup>

		MIN	MAX	UNIT
$V_{CC}$	Supply voltage	-0.5	6.5	V
$V_I$	Input voltage <sup>(2)</sup>	-0.5	6.5	V
$V_O$	Output voltage	-0.5	6.5	V
$I_{IK}$	Input clamp current	$V_I < 0$	-50	mA
$I_{OK}$	Output clamp current	$V_O < 0$	-50	mA
$I_O$	Continuous output current		±50	mA
	Continuous current through $V_{CC}$ or GND		±100	mA
$T_j$	Junction temperature		150	°C
$T_{stg}$	Storage temperature	-65	150	°C

- (1) Stresses beyond those listed under *Absolute Maximum Ratings* may cause permanent damage to the device. These are stress ratings only, and functional operation of the device at these or any other conditions beyond those indicated under *Recommended Operating Conditions* is not implied. Exposure to absolute-maximum-rated conditions for extended periods may affect device reliability.
- (2) The input and output negative-voltage ratings may be exceeded if the input and output current ratings are observed.

### 6.2 ESD Ratings

		VALUE	UNIT
$V_{(ESD)}$	Electrostatic discharge	Human body model (HBM), per ANSI/ESDA/JEDEC JS-001 <sup>(1)</sup>	±4000
		Charged device model (CDM), per JEDEC specification JESD22-C101 <sup>(2)</sup>	±1500

- (1) JEDEC document JEP155 states that 500-V HBM allows safe manufacturing with a standard ESD control process.
- (2) JEDEC document JEP157 states that 250-V CDM allows safe manufacturing with a standard ESD control process.

### 6.3 Recommended Operating Conditions

over operating free-air temperature range (unless otherwise noted)<sup>(1)</sup>

		MIN	MAX	UNIT
$V_{CC}$	Supply voltage	1.65	5.5	V
$V_{IH}$	High-level input voltage	$V_{CC} = 1.65\text{ V to }1.95\text{ V}$	$0.65 \times V_{CC}$	V
		$V_{CC} = 2.3\text{ V to }2.7\text{ V}$	1.7	
		$V_{CC} = 2.7\text{ V to }3.6\text{ V}$	2	
		$V_{CC} = 4.5\text{ V to }5.5\text{ V}$	$0.7 \times V_{CC}$	
$V_{IL}$	Low-level input voltage	$V_{CC} = 1.65\text{ V to }1.95\text{ V}$	$0.35 \times V_{CC}$	V
		$V_{CC} = 2.3\text{ V to }2.7\text{ V}$	0.7	
		$V_{CC} = 2.7\text{ V to }3.6\text{ V}$	0.8	
		$V_{CC} = 4.5\text{ V to }5.5\text{ V}$	$0.3 \times V_{CC}$	
$V_I$	Input voltage	0	5.5	V
$V_O$	Output voltage	0	5.5	V
$I_{OL}$	Low-level output current	$V_{CC} = 1.65\text{ V}$	4	mA
		$V_{CC} = 2.3\text{ V}$	12	
		$V_{CC} = 2.7\text{ V}$	12	
		$V_{CC} = 3\text{ V}$	24	
		$V_{CC} = 4.5\text{ V}$	24	
$T_A$	Operating free-air temperature	-40	125	°C

- (1) All unused inputs of the device must be held at  $V_{CC}$  or GND to ensure proper device operation. See [Implications of Slow or Floating CMOS Inputs](#), SCBA004.

## 6.4 Thermal Information

THERMAL METRIC <sup>(1)</sup>		SN74LVC07A						UNIT
		D (SOIC)	DB (SSOP)	DGV (TVSOP)	NS (SO)	PW (TSSOP)	RGY (VQFN)	
		14 PINS						
$R_{\theta JA}$	Junction-to-ambient thermal resistance	177.4	135.1	157.7	120.3	160.3	80.6	°C/W
$R_{\theta JC(top)}$	Junction-to-case (top) thermal resistance	75.4	86.7	78.3	76.3	84.4	97.0	°C/W
$R_{\theta JB}$	Junction-to-board thermal resistance	70.6	82.4	90.8	79.0	102.1	56.7	°C/W
$\Psi_{JT}$	Junction-to-top characterization parameter	34.7	43.7	21.0	36.2	24.3	16.7	°C/W
$\Psi_{JB}$	Junction-to-board characterization parameter	70.4	81.9	90.1	78.7	101.4	56.8	°C/W
$R_{\theta JC(bot)}$	Junction-to-case (bottom) thermal resistance	n/a	n/a	n/a	n/a	n/a	35.8	°C/W

(1) For more information about traditional and new thermal metrics, see the [Semiconductor and IC Package Thermal Metrics](#) application report.

## 6.5 Electrical Characteristics—DC Limit Changes

$T_A = -40^\circ\text{C}$  to  $+125^\circ\text{C}$ , unless otherwise noted

PARAMETER	TEST CONDITIONS	$V_{CC}$	MIN	TYP <sup>(1)</sup>	MAX	UNIT
$V_{OL}$	$I_{OL} = 100 \mu\text{A}$	1.65 V to 5.5 V			0.2	V
	$I_{OL} = 4 \text{ mA}$	1.65 V			0.45	
	$I_{OL} = 12 \text{ mA}$	2.3 V			0.7	
		2.7 V			0.4	
	$I_{OL} = 24 \text{ mA}$	3 V			0.55	
$I_I$	$V_I = 5.5 \text{ V}$ or GND	3.6 V			$\pm 5$	$\mu\text{A}$
$I_{off}$	$V_I$ or $V_O = 5.5 \text{ V}$	0 V			$\pm 10$	$\mu\text{A}$
$I_{CC}$	$V_I = V_{CC}$ or GND, $I_O = 0$	3.6 V			10	$\mu\text{A}$
$\Delta I_{CC}$	One input at $V_{CC} - 0.6 \text{ V}$ , Other inputs at $V_{CC}$ or GND	2.7 V to 3.6 V			500	$\mu\text{A}$
$C_i$	$V_I = V_{CC}$ or GND	3.3 V		5.0		pF

(1) All typical values are at  $V_{CC} = 3.3 \text{ V}$ ,  $T_A = 25^\circ\text{C}$ .

## 6.6 Switching Characteristics

over recommended operating free-air temperature range (unless otherwise noted) (see [Figure 3](#) through [Figure 6](#))

PARAMETER	FROM (INPUT)	TO (OUTPUT)	TEST CONDITIONS		MIN	MAX	UNIT
$t_{pd}$	A	Y	-40°C to 85°C	$V_{CC} = 1.8 \text{ V} \pm 0.15 \text{ V}$	1	5.6	ns
				$V_{CC} = 2.5 \text{ V} \pm 0.2 \text{ V}$	1	3.4	
				$V_{CC} = 2.7 \text{ V}$	1	3.3	
				$V_{CC} = 3.3 \text{ V} \pm 0.3 \text{ V}$	1	3.6	
				$V_{CC} = 5 \text{ V} \pm 0.5 \text{ V}$	1	2.6	
			-40°C to 125°C	$V_{CC} = 1.8 \text{ V} \pm 0.15 \text{ V}$	1	6.1	
				$V_{CC} = 2.5 \text{ V} \pm 0.2 \text{ V}$	1	3.9	
				$V_{CC} = 2.7 \text{ V}$	1	3.8	
				$V_{CC} = 3.3 \text{ V} \pm 0.3 \text{ V}$	1	4.1	
				$V_{CC} = 5 \text{ V} \pm 0.5 \text{ V}$	1	3.1	

### 6.7 Operating Characteristics

T<sub>A</sub> = 25°C

PARAMETER	TEST CONDITIONS	V <sub>CC</sub> = 1.8 V	V <sub>CC</sub> = 2.5 V	V <sub>CC</sub> = 3.3 V	V <sub>CC</sub> = 5 V	UNIT
		TYP	TYP	TYP	TYP	
C <sub>pd</sub> Power dissipation capacitance per buffer and driver	f = 10 MHz	1.8	2	2.5	3.78	pF

### 6.8 Typical Characteristics

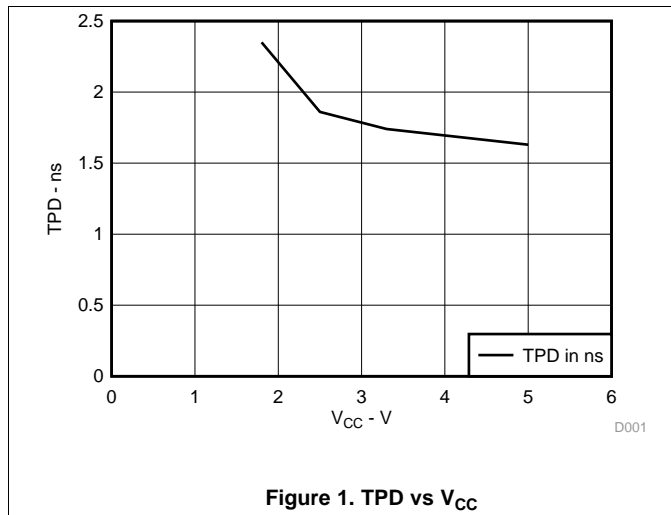

Figure 1. TPD vs V<sub>CC</sub>

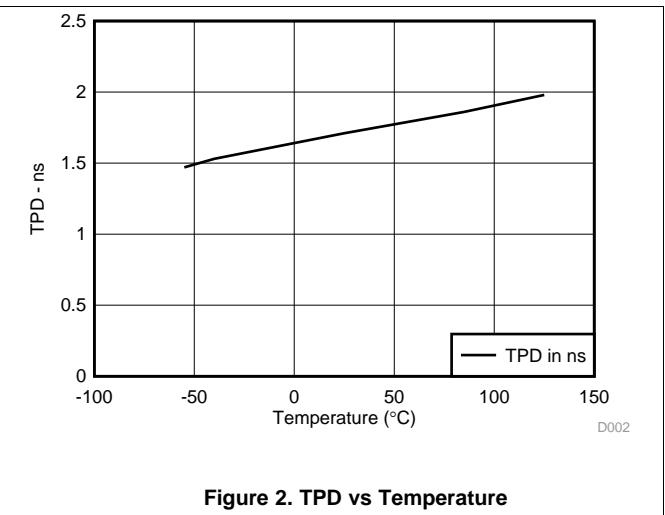
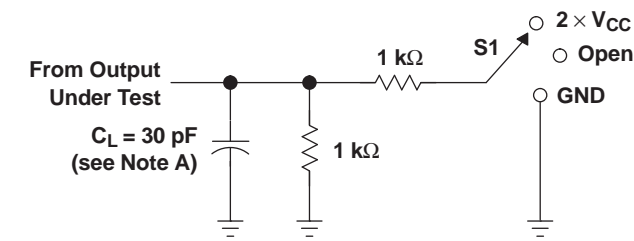
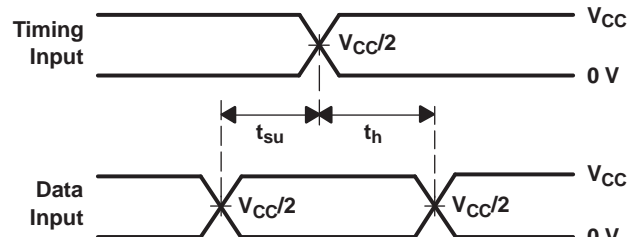
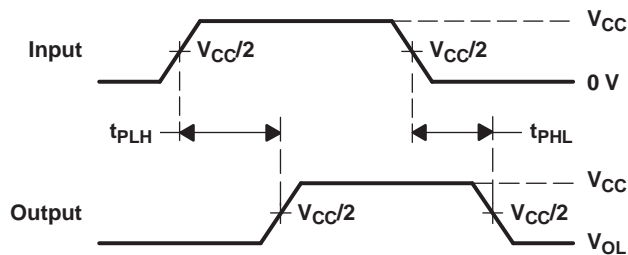

Figure 2. TPD vs Temperature

## 7 Parameter Measurement Information

### 7.1 $V_{CC} = 1.8\text{ V} \pm 0.15\text{ V}$

**LOAD CIRCUIT**

**VOLTAGE WAVEFORMS  
SETUP AND HOLD TIMES**

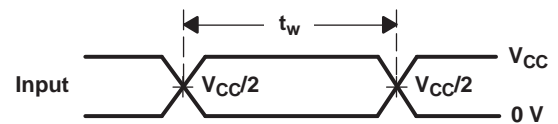
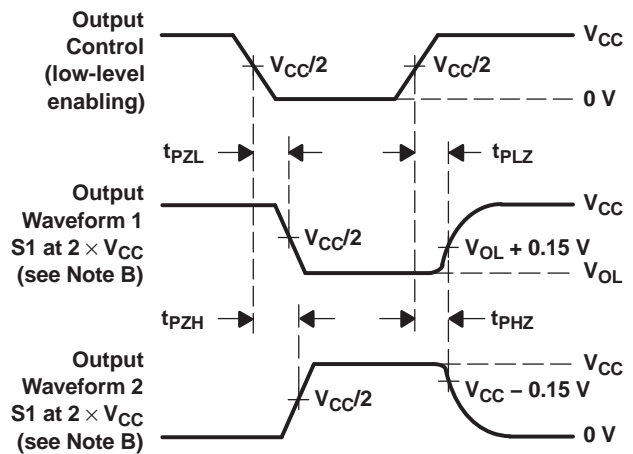
**VOLTAGE WAVEFORMS  
PROPAGATION DELAY TIMES**

TEST	S1
$t_{PZL}$ (see Note F)	2 $\times$ $V_{CC}$
$t_{PLZ}$ (see Note G)	2 $\times$ $V_{CC}$
$t_{PHZ}/t_{PZH}$	2 $\times$ $V_{CC}$

**VOLTAGE WAVEFORMS  
PULSE DURATION**

**VOLTAGE WAVEFORMS  
ENABLE AND DISABLE TIMES**

- NOTES:
- $C_L$  includes probe and jig capacitance.
  - Waveform 1 is for an output with internal conditions such that the output is low, except when disabled by the output control. Waveform 2 is for an output with internal conditions such that the output is high, except when disabled by the output control.
  - All input pulses are supplied by generators having the following characteristics:  $PRR \leq 10\text{ MHz}$ ,  $Z_O = 50\ \Omega$ ,  $t_r \leq 2\text{ ns}$ ,  $t_f \leq 2\text{ ns}$ .
  - The outputs are measured one at a time, with one transition per measurement.
  - Since this device has open-drain outputs,  $t_{PLZ}$  and  $t_{PZL}$  are the same as  $t_{pd}$ .
  - $t_{PZL}$  is measured at  $V_{CC}/2$ .
  - $t_{PLZ}$  is measured at  $V_{OL} + 0.15\text{ V}$ .
  - All parameters and waveforms are not applicable to all devices.

**Figure 3. Load Circuit and Voltage Waveforms**

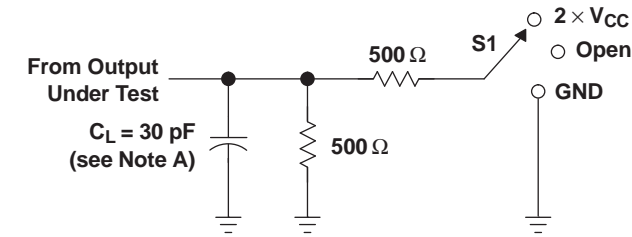
7.2  $V_{CC} = 2.5 V \pm 0.2 V$



LOAD CIRCUIT

TEST	S1
$t_{PZL}$ (see Note F)	$2 \times V_{CC}$
$t_{PLZ}$ (see Note G)	$2 \times V_{CC}$
$t_{PHZ}/t_{PZH}$	$2 \times V_{CC}$

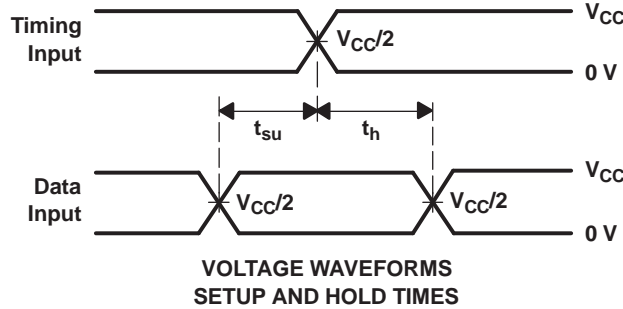

VOLTAGE WAVEFORMS SETUP AND HOLD TIMES

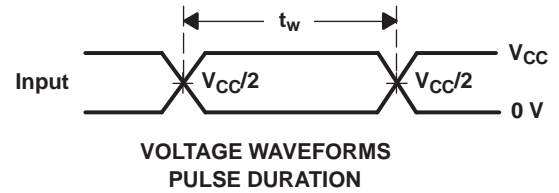

VOLTAGE WAVEFORMS PULSE DURATION

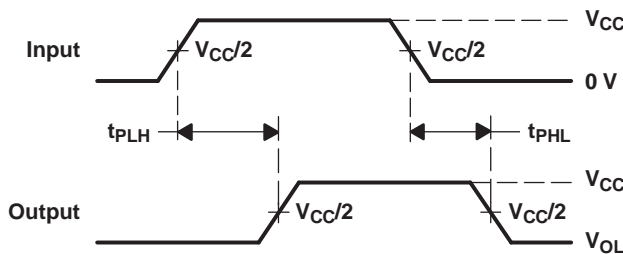

VOLTAGE WAVEFORMS PROPAGATION DELAY TIMES

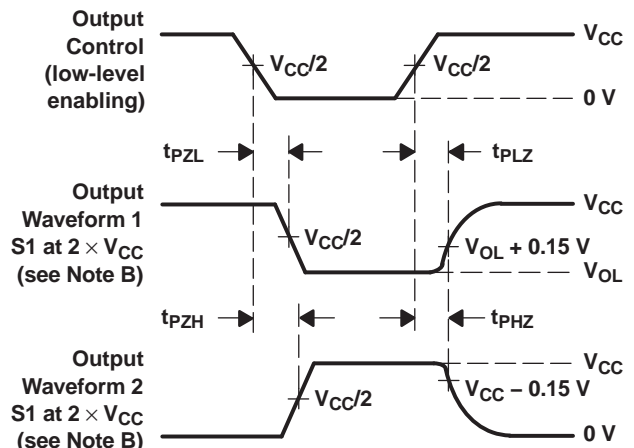

VOLTAGE WAVEFORMS ENABLE AND DISABLE TIMES

- NOTES:
- A.  $C_L$  includes probe and jig capacitance.
  - B. Waveform 1 is for an output with internal conditions such that the output is low, except when disabled by the output control. Waveform 2 is for an output with internal conditions such that the output is high, except when disabled by the output control.
  - C. All input pulses are supplied by generators having the following characteristics:  $PRR \leq 10 \text{ MHz}$ ,  $Z_O = 50 \Omega$ ,  $t_r \leq 2 \text{ ns}$ ,  $t_f \leq 2 \text{ ns}$ .
  - D. The outputs are measured one at a time, with one transition per measurement.
  - E. Since this device has open-drain outputs,  $t_{PLZ}$  and  $t_{PZL}$  are the same as  $t_{pd}$ .
  - F.  $t_{PZL}$  is measured at  $V_{CC}/2$ .
  - G.  $t_{PLZ}$  is measured at  $V_{OL} + 0.15 \text{ V}$ .
  - H. All parameters and waveforms are not applicable to all devices.

Figure 4. Load Circuit and Voltage Waveforms

### SN74LVC07A

SCAS595W – OCTOBER 1997 – REVISED OCTOBER 2016

www.ti.com

### 7.3 $V_{CC} = 2.7$ and $3.3\text{ V} \pm 0.3\text{ V}$

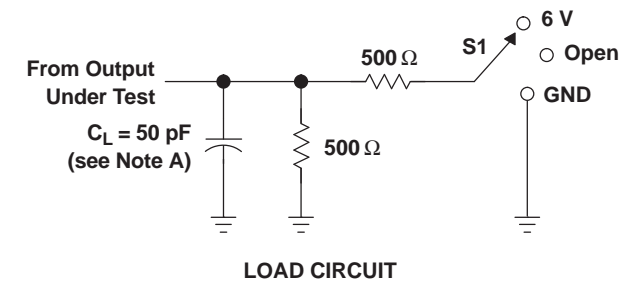

TEST	S1
$t_{pZL}$ (see Note F)	6 V
$t_{pLZ}$ (see Note G)	6 V
$t_{PHZ}/t_{PZH}$	6 V

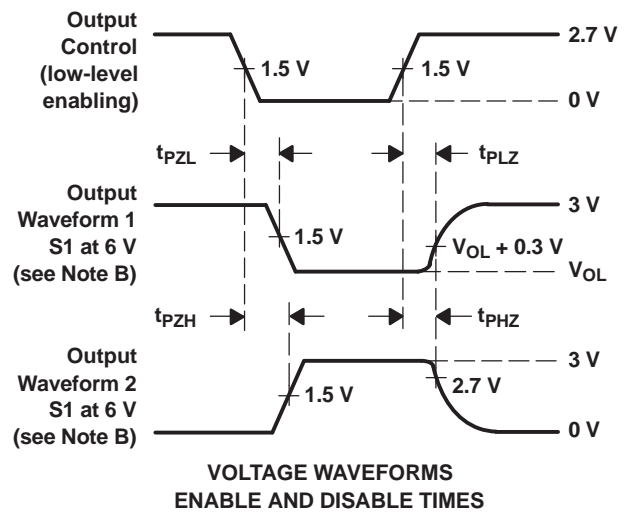
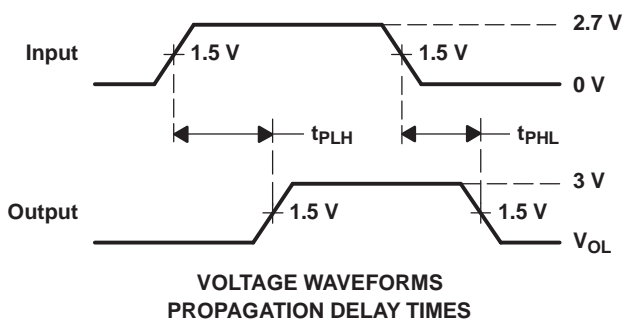
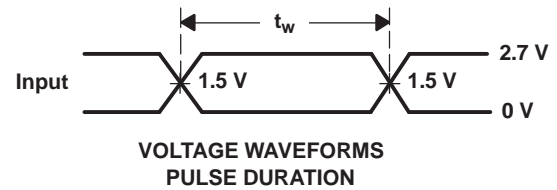
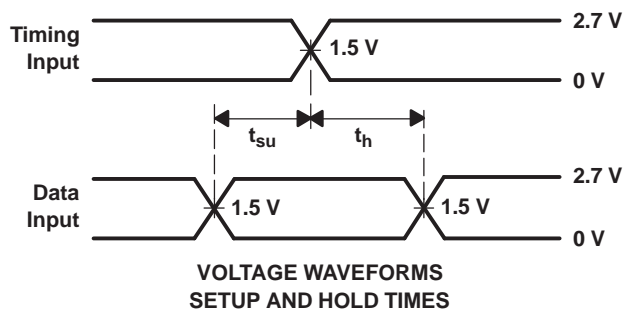

- NOTES: A.  $C_L$  includes probe and jig capacitance.  
 B. Waveform 1 is for an output with internal conditions such that the output is low, except when disabled by the output control. Waveform 2 is for an output with internal conditions such that the output is high, except when disabled by the output control.  
 C. All input pulses are supplied by generators having the following characteristics:  $PRR \leq 10\text{ MHz}$ ,  $Z_O = 50\ \Omega$ ,  $t_r \leq 2.5\text{ ns}$ ,  $t_f \leq 2.5\text{ ns}$ .  
 D. The outputs are measured one at a time, with one transition per measurement.  
 E. Since this device has open-drain outputs,  $t_{pLZ}$  and  $t_{pZL}$  are the same as  $t_{pd}$ .  
 F.  $t_{pZL}$  is measured at 1.5 V.  
 G.  $t_{pLZ}$  is measured at  $V_{OL} + 0.3\text{ V}$ .  
 H. All parameters and waveforms are not applicable to all devices.

**Figure 5. Load Circuit and Voltage Waveforms**

7.4  $V_{CC} = 5 V \pm 0.5 V$

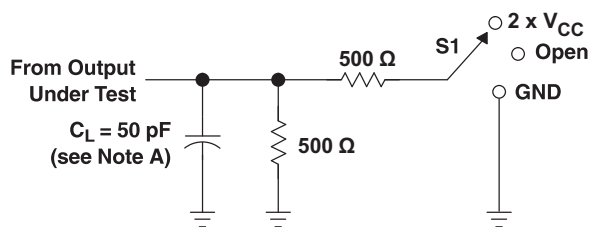

LOAD CIRCUIT

TEST	S1
$t_{pZL}$ (see Note F)	$2 \times V_{CC}$
$t_{pLZ}$ (see Note G)	$2 \times V_{CC}$
$t_{PHZ}/t_{PZH}$	$2 \times V_{CC}$

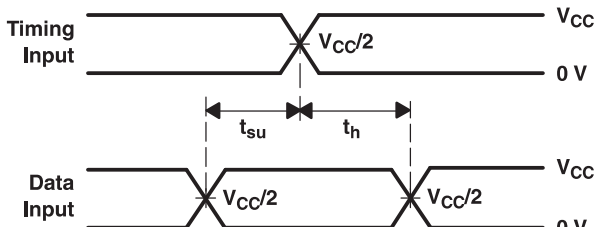

VOLTAGE WAVEFORMS SETUP AND HOLD TIMES

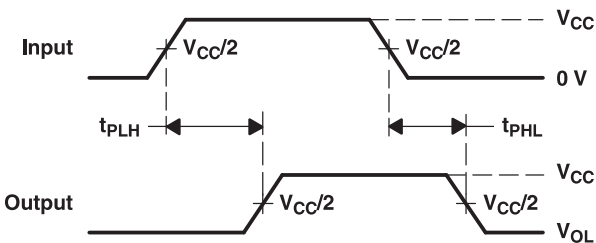

VOLTAGE WAVEFORMS PROPAGATION DELAY TIMES

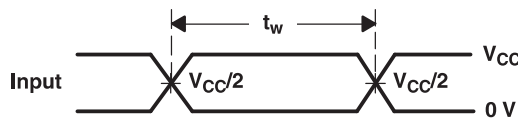

VOLTAGE WAVEFORMS PULSE DURATION

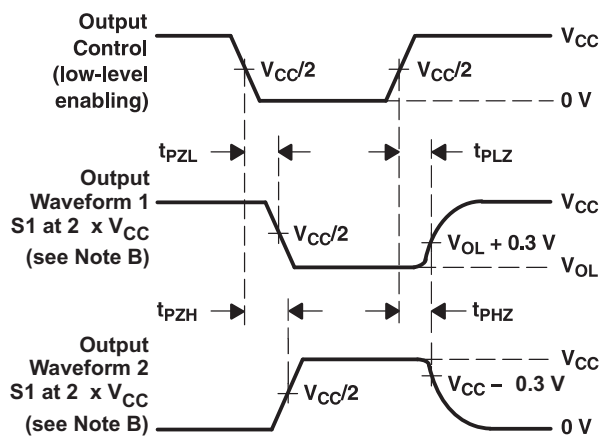

VOLTAGE WAVEFORMS ENABLE AND DISABLE TIMES

- NOTES:
- A.  $C_L$  includes probe and jig capacitance.
  - B. Waveform 1 is for an output with internal connections such that the output is low, except when disabled by the output control. Waveform 2 is for an output with internal connections such that the output is high, except when disabled by the output control.
  - C. All input pulses are supplied by generators having the following characteristics:  $PRR \leq 10 \text{ MHz}$ ,  $Z_O = 50 \Omega$ ,  $t_r \leq 2.5 \text{ ns}$ ,  $t_f \leq 2.5 \text{ ns}$ .
  - D. The outputs are measured one at a time, with one transition per measurement.
  - E. Since this device has open-drain outputs,  $t_{pLZ}$  and  $t_{pZL}$  are the same as  $t_{pd}$ .
  - F.  $t_{pZL}$  is measured at  $V_{CC}/2$ .
  - G.  $t_{pLZ}$  is measured at  $V_{OL} + 0.3 \text{ V}$ .
  - H. All parameters and waveforms are not applicable to all devices.

Figure 6. Load Circuit and Voltage Waveforms

## 8 Detailed Description

### 8.1 Overview

The outputs of the SN74LVC07A device are open drain and can be connected to other open-drain outputs to implement active-low wired-OR or active-high wired-AND functions. The maximum sink current is 24 mA.

Inputs can be driven from 1.8-V, 2.5-V, 3.3-V (LVTTTL), or 5-V (CMOS) devices. This feature allows the use of this device as translators in a mixed-system environment.

This device is fully specified for partial-power-down applications using  $I_{off}$ . The  $I_{off}$  circuitry disables the outputs, preventing damaging current backflow through the device when it is powered down.

### 8.2 Functional Block Diagram

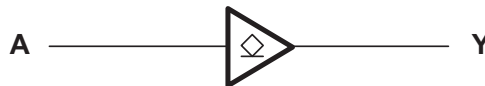

Copyright © 2016 Texas Instruments Incorporated

### 8.3 Feature Description

- Wide operating voltage range
  - Operates from 1.65 V to 5.5 V
- Allows up or down voltage translation
  - Inputs and outputs accept voltages to 5.5 V
- $I_{off}$  feature
  - Allows voltages on the inputs and outputs when  $V_{CC}$  is 0 V

### 8.4 Device Functional Modes

[Table 1](#) lists the functional modes of the SN74LVC07A.

**Table 1. Function Table**

INPUT A	OUTPUT Y
H	Hi-Z
L	L

## 9 Application and Implementation

### NOTE

Information in the following applications sections is not part of the TI component specification, and TI does not warrant its accuracy or completeness. TI's customers are responsible for determining suitability of components for their purposes. Customers should validate and test their design implementation to confirm system functionality.

### 9.1 Application Information

The SN74LVC07A device is a high-drive, open-drain CMOS device that can be used for a multitude of buffer-type functions. It can produce 24 mA of drive current at 3.3 V. Therefore, this device is ideal for driving multiple inputs and for high-speed applications up to 100 MHz. The inputs and outputs are 5.5-V tolerant allowing the device to translate up to 5.5 V or down to  $V_{CC}$ .

### 9.2 Typical Application

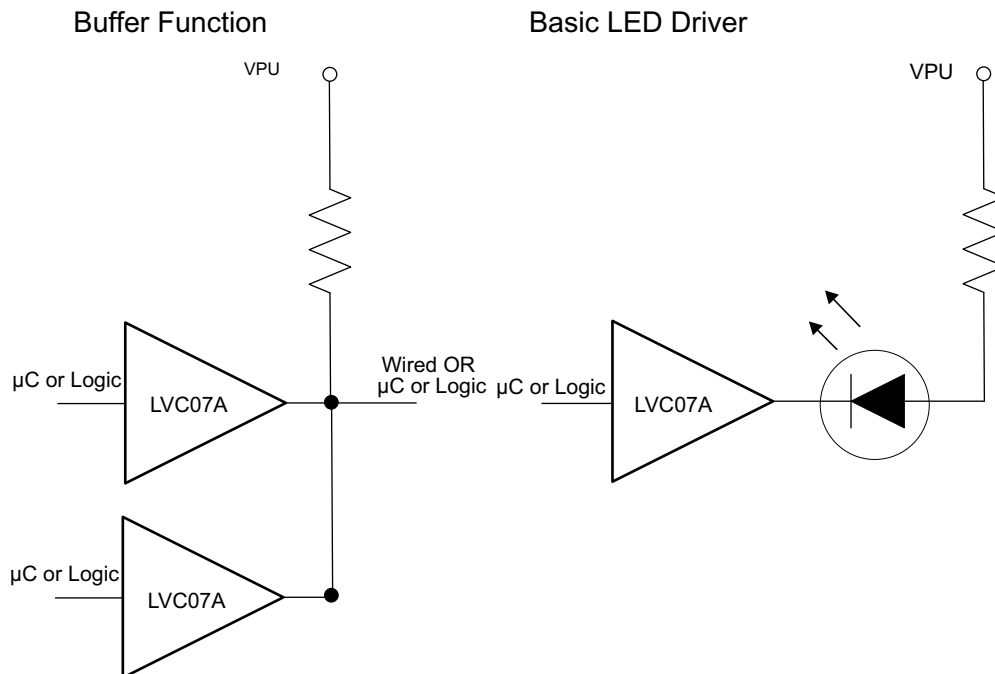

Copyright © 2016 Texas Instruments Incorporated

Figure 7. Typical Application Diagram

#### 9.2.1 Design Requirements

This device uses CMOS technology and has balanced output drive. Take care to avoid bus contention because it can drive currents that would exceed maximum limits. The high drive will also create fast edges into light loads; therefore, routing and load conditions must be considered to prevent ringing.

#### 9.2.2 Detailed Design Procedure

1. Recommended Input Conditions
  - Rise time and fall time specs: See  $(\Delta t/\Delta V)$  in the [Recommended Operating Conditions](#) table.
  - Specified high and low levels: See  $(V_{IH}$  and  $V_{IL})$  in the [Recommended Operating Conditions](#) table.
  - Inputs are overvoltage tolerant allowing them to go as high as 5.5 V at any valid  $V_{CC}$ .
2. Recommended Output Conditions

## Typical Application (continued)

- Load currents must not exceed 25 mA per output and 50 mA total for the part.
- Outputs must not be pulled above 5.5 V.

### 9.2.3 Application Curve

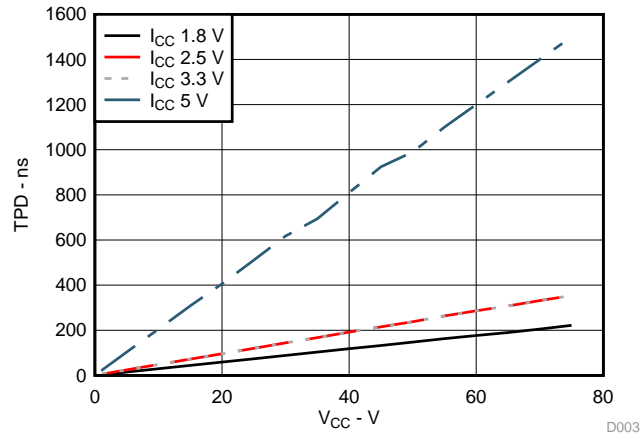

**Figure 8. I<sub>CC</sub> vs Frequency**

## 10 Power Supply Recommendations

The power supply can be any voltage between the MIN and MAX supply voltage rating located in the [Recommended Operating Conditions](#) table.

Each V<sub>CC</sub> pin must have a good bypass capacitor to prevent power disturbance. For devices with a single supply, 0.1 μf is recommended; if there are multiple V<sub>CC</sub> pins, then 0.01 μf or 0.022 μf is recommended for each power pin. It is acceptable to parallel multiple bypass caps to reject different frequencies of noise. A 0.1 μf and a 1 μf are commonly used in parallel. The bypass capacitor must be installed as close to the power pin as possible for best results.

## 11 Layout

### 11.1 Layout Guidelines

When using multiple bit logic devices inputs must never float.

In many cases, functions or parts of functions of digital logic devices are unused, for example, when only two inputs of a triple-input AND gate are used or only 3 of the 4 buffer gates are used. Such input pins must not be left unconnected because the undefined voltages at the outside connections result in undefined operational states. [Figure 9](#) specifies the rules that must be observed under all circumstances. All unused inputs of digital logic devices must be connected to a high or low bias to prevent them from floating. The logic level that must be applied to any particular unused input depends on the function of the device. Generally they will be tied to GND or V<sub>CC</sub>, whichever makes more sense or is more convenient. It is generally acceptable to float outputs, unless the part is a transceiver.

### 11.2 Layout Example

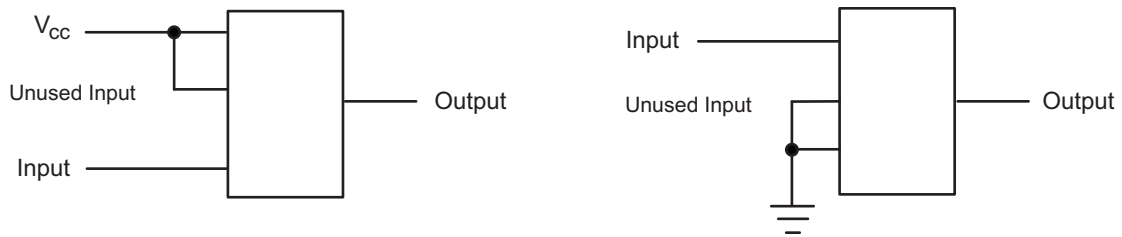

**Figure 9. Layout Diagram**

## 12 Device and Documentation Support

### 12.1 Documentation Support

#### 12.1.1 Related Documentation

For related documentation see the following:

- [Implications of Slow or Floating CMOS Inputs](#), SCBA004.
- [Semiconductor and IC Package Thermal Metrics](#), SPRA953.

### 12.2 Receiving Notification of Documentation Updates

To receive notification of documentation updates, navigate to the device product folder on ti.com. In the upper right corner, click on *Alert me* to register and receive a weekly digest of any product information that has changed. For change details, review the revision history included in any revised document.

### 12.3 Community Resources

The following links connect to TI community resources. Linked contents are provided "AS IS" by the respective contributors. They do not constitute TI specifications and do not necessarily reflect TI's views; see TI's [Terms of Use](#).

**TI E2E™ Online Community** *TI's Engineer-to-Engineer (E2E) Community*. Created to foster collaboration among engineers. At [e2e.ti.com](http://e2e.ti.com), you can ask questions, share knowledge, explore ideas and help solve problems with fellow engineers.

**Design Support** *TI's Design Support* Quickly find helpful E2E forums along with design support tools and contact information for technical support.

### 12.4 Trademarks

E2E is a trademark of Texas Instruments.  
All other trademarks are the property of their respective owners.

### 12.5 Electrostatic Discharge Caution



These devices have limited built-in ESD protection. The leads should be shorted together or the device placed in conductive foam during storage or handling to prevent electrostatic damage to the MOS gates.

### 12.6 Glossary

[SLYZ022](#) — *TI Glossary*.

This glossary lists and explains terms, acronyms, and definitions.

## 13 Mechanical, Packaging, and Orderable Information

The following pages include mechanical, packaging, and orderable information. This information is the most current data available for the designated devices. This data is subject to change without notice and revision of this document. For browser-based versions of this data sheet, refer to the left-hand navigation.

**PACKAGING INFORMATION**

Orderable Device	Status (1)	Package Type	Package Drawing	Pins	Package Qty	Eco Plan (2)	Lead/Ball Finish (6)	MSL Peak Temp (3)	Op Temp (°C)	Device Marking (4/5)	Samples
SN74LVC07AD	ACTIVE	SOIC	D	14	50	Green (RoHS & no Sb/Br)	CU NIPDAU	Level-1-260C-UNLIM	-40 to 125	LVC07A	<a href="#">Samples</a>
SN74LVC07ADBR	ACTIVE	SSOP	DB	14	2000	Green (RoHS & no Sb/Br)	CU NIPDAU	Level-1-260C-UNLIM	-40 to 125	LC07A	<a href="#">Samples</a>
SN74LVC07ADBRG4	ACTIVE	SSOP	DB	14	2000	Green (RoHS & no Sb/Br)	CU NIPDAU	Level-1-260C-UNLIM	-40 to 125	LC07A	<a href="#">Samples</a>
SN74LVC07ADE4	ACTIVE	SOIC	D	14	50	Green (RoHS & no Sb/Br)	CU NIPDAU	Level-1-260C-UNLIM	-40 to 125	LVC07A	<a href="#">Samples</a>
SN74LVC07ADGVR	ACTIVE	TVSOP	DGV	14	2000	Green (RoHS & no Sb/Br)	CU NIPDAU	Level-1-260C-UNLIM	-40 to 125	LC07A	<a href="#">Samples</a>
SN74LVC07ADR	ACTIVE	SOIC	D	14	2500	Green (RoHS & no Sb/Br)	CU NIPDAU   CU SN	Level-1-260C-UNLIM	-40 to 125	LVC07A	<a href="#">Samples</a>
SN74LVC07ADRG3	ACTIVE	SOIC	D	14	2500	Green (RoHS & no Sb/Br)	CU SN	Level-1-260C-UNLIM	-40 to 125	LVC07A	<a href="#">Samples</a>
SN74LVC07ADRG4	ACTIVE	SOIC	D	14	2500	Green (RoHS & no Sb/Br)	CU NIPDAU	Level-1-260C-UNLIM	-40 to 125	LVC07A	<a href="#">Samples</a>
SN74LVC07ADT	ACTIVE	SOIC	D	14	250	Green (RoHS & no Sb/Br)	CU NIPDAU	Level-1-260C-UNLIM	-40 to 125	LVC07A	<a href="#">Samples</a>
SN74LVC07ANSR	ACTIVE	SO	NS	14	2000	Green (RoHS & no Sb/Br)	CU NIPDAU	Level-1-260C-UNLIM	-40 to 125	LVC07A	<a href="#">Samples</a>
SN74LVC07APW	ACTIVE	TSSOP	PW	14	90	Green (RoHS & no Sb/Br)	CU NIPDAU	Level-1-260C-UNLIM	-40 to 125	LC07A	<a href="#">Samples</a>
SN74LVC07APWE4	ACTIVE	TSSOP	PW	14	90	Green (RoHS & no Sb/Br)	CU NIPDAU	Level-1-260C-UNLIM	-40 to 125	LC07A	<a href="#">Samples</a>
SN74LVC07APWG4	ACTIVE	TSSOP	PW	14	90	Green (RoHS & no Sb/Br)	CU NIPDAU	Level-1-260C-UNLIM	-40 to 125	LC07A	<a href="#">Samples</a>
SN74LVC07APWR	ACTIVE	TSSOP	PW	14	2000	Green (RoHS & no Sb/Br)	CU NIPDAU   CU SN	Level-1-260C-UNLIM	-40 to 125	LC07A	<a href="#">Samples</a>
SN74LVC07APWRE4	ACTIVE	TSSOP	PW	14	2000	Green (RoHS & no Sb/Br)	CU NIPDAU	Level-1-260C-UNLIM	-40 to 125	LC07A	<a href="#">Samples</a>
SN74LVC07APWRG3	ACTIVE	TSSOP	PW	14	2000	Green (RoHS & no Sb/Br)	CU SN	Level-1-260C-UNLIM	-40 to 125	LC07A	<a href="#">Samples</a>
SN74LVC07APWRG4	ACTIVE	TSSOP	PW	14	2000	Green (RoHS & no Sb/Br)	CU NIPDAU	Level-1-260C-UNLIM	-40 to 125	LC07A	<a href="#">Samples</a>

Orderable Device	Status (1)	Package Type	Package Drawing	Pins	Package Qty	Eco Plan (2)	Lead/Ball Finish (6)	MSL Peak Temp (3)	Op Temp (°C)	Device Marking (4/5)	Samples
SN74LVC07APWT	ACTIVE	TSSOP	PW	14	250	Green (RoHS & no Sb/Br)	CU NIPDAU	Level-1-260C-UNLIM	-40 to 125	LC07A	<a href="#">Samples</a>
SN74LVC07APWTG4	ACTIVE	TSSOP	PW	14	250	Green (RoHS & no Sb/Br)	CU NIPDAU	Level-1-260C-UNLIM	-40 to 125	LC07A	<a href="#">Samples</a>
SN74LVC07ARGYR	ACTIVE	VQFN	RGY	14	3000	Green (RoHS & no Sb/Br)	CU NIPDAU	Level-2-260C-1 YEAR	-40 to 125	LC07A	<a href="#">Samples</a>
SN74LVC07ARGYRG4	ACTIVE	VQFN	RGY	14	3000	Green (RoHS & no Sb/Br)	CU NIPDAU	Level-2-260C-1 YEAR	-40 to 125	LC07A	<a href="#">Samples</a>

(1) The marketing status values are defined as follows:

**ACTIVE:** Product device recommended for new designs.

**LIFEBUY:** TI has announced that the device will be discontinued, and a lifetime-buy period is in effect.

**NRND:** Not recommended for new designs. Device is in production to support existing customers, but TI does not recommend using this part in a new design.

**PREVIEW:** Device has been announced but is not in production. Samples may or may not be available.

**OBsolete:** TI has discontinued the production of the device.

(2) **RoHS:** TI defines "RoHS" to mean semiconductor products that are compliant with the current EU RoHS requirements for all 10 RoHS substances, including the requirement that RoHS substance do not exceed 0.1% by weight in homogeneous materials. Where designed to be soldered at high temperatures, "RoHS" products are suitable for use in specified lead-free processes. TI may reference these types of products as "Pb-Free".

**RoHS Exempt:** TI defines "RoHS Exempt" to mean products that contain lead but are compliant with EU RoHS pursuant to a specific EU RoHS exemption.

**Green:** TI defines "Green" to mean the content of Chlorine (Cl) and Bromine (Br) based flame retardants meet JS709B low halogen requirements of <=1000ppm threshold. Antimony trioxide based flame retardants must also meet the <=1000ppm threshold requirement.

(3) MSL, Peak Temp. - The Moisture Sensitivity Level rating according to the JEDEC industry standard classifications, and peak solder temperature.

(4) There may be additional marking, which relates to the logo, the lot trace code information, or the environmental category on the device.

(5) Multiple Device Markings will be inside parentheses. Only one Device Marking contained in parentheses and separated by a "~" will appear on a device. If a line is indented then it is a continuation of the previous line and the two combined represent the entire Device Marking for that device.

(6) Lead/Ball Finish - Orderable Devices may have multiple material finish options. Finish options are separated by a vertical ruled line. Lead/Ball Finish values may wrap to two lines if the finish value exceeds the maximum column width.

**Important Information and Disclaimer:**The information provided on this page represents TI's knowledge and belief as of the date that it is provided. TI bases its knowledge and belief on information provided by third parties, and makes no representation or warranty as to the accuracy of such information. Efforts are underway to better integrate information from third parties. TI has taken and continues to take reasonable steps to provide representative and accurate information but may not have conducted destructive testing or chemical analysis on incoming materials and chemicals. TI and TI suppliers consider certain information to be proprietary, and thus CAS numbers and other limited information may not be available for release.

In no event shall TI's liability arising out of such information exceed the total purchase price of the TI part(s) at issue in this document sold by TI to Customer on an annual basis.

**OTHER QUALIFIED VERSIONS OF SN74LVC07A :**

- Automotive: [SN74LVC07A-Q1](#)
- Enhanced Product: [SN74LVC07A-EP](#)

## NOTE: Qualified Version Definitions:

- Automotive - Q100 devices qualified for high-reliability automotive applications targeting zero defects
- Enhanced Product - Supports Defense, Aerospace and Medical Applications

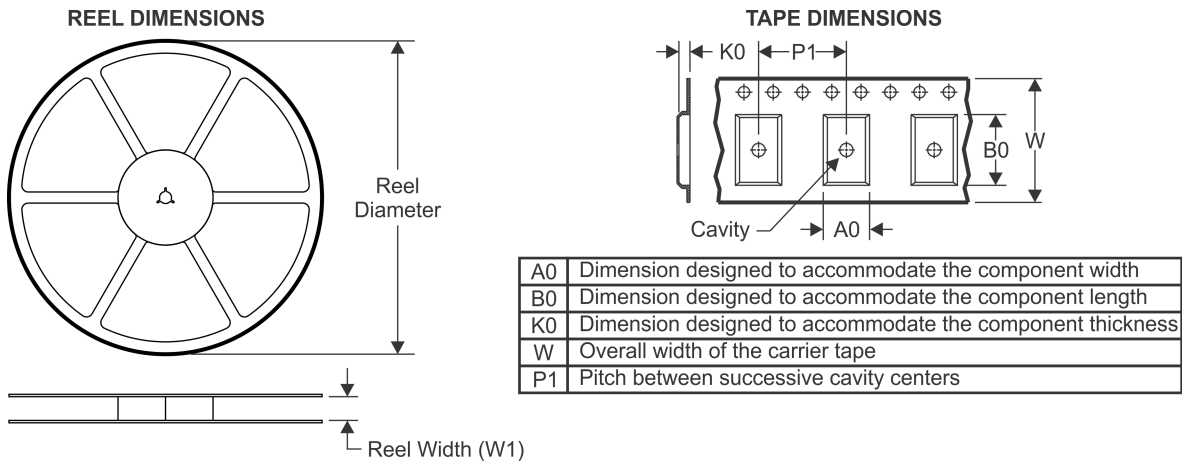
**TAPE AND REEL INFORMATION**

**QUADRANT ASSIGNMENTS FOR PIN 1 ORIENTATION IN TAPE**

\*All dimensions are nominal

Device	Package Type	Package Drawing	Pins	SPQ	Reel Diameter (mm)	Reel Width W1 (mm)	A0 (mm)	B0 (mm)	K0 (mm)	P1 (mm)	W (mm)	Pin1 Quadrant
SN74LVC07ADGVR	TVSOP	DGV	14	2000	330.0	12.4	6.8	4.0	1.6	8.0	12.0	Q1
SN74LVC07ADR	SOIC	D	14	2500	330.0	16.4	6.5	9.0	2.1	8.0	16.0	Q1
SN74LVC07ADR	SOIC	D	14	2500	330.0	16.8	6.5	9.5	2.1	8.0	16.0	Q1
SN74LVC07ADR	SOIC	D	14	2500	330.0	16.4	6.5	9.0	2.1	8.0	16.0	Q1
SN74LVC07ADRG3	SOIC	D	14	2500	330.0	16.8	6.5	9.5	2.1	8.0	16.0	Q1
SN74LVC07ADRG4	SOIC	D	14	2500	330.0	16.4	6.5	9.0	2.1	8.0	16.0	Q1
SN74LVC07ADRG4	SOIC	D	14	2500	330.0	16.4	6.5	9.0	2.1	8.0	16.0	Q1
SN74LVC07ADT	SOIC	D	14	250	330.0	16.4	6.5	9.0	2.1	8.0	16.0	Q1
SN74LVC07ANSR	SO	NS	14	2000	330.0	16.4	8.2	10.5	2.5	12.0	16.0	Q1
SN74LVC07APWR	TSSOP	PW	14	2000	330.0	12.4	6.9	5.6	1.6	8.0	12.0	Q1
SN74LVC07APWRG3	TSSOP	PW	14	2000	330.0	12.4	6.9	5.6	1.6	8.0	12.0	Q1
SN74LVC07APWRG4	TSSOP	PW	14	2000	330.0	12.4	6.9	5.6	1.6	8.0	12.0	Q1
SN74LVC07APWT	TSSOP	PW	14	250	330.0	12.4	6.9	5.6	1.6	8.0	12.0	Q1
SN74LVC07ARGYR	VQFN	RGY	14	3000	330.0	12.4	3.75	3.75	1.15	8.0	12.0	Q1

**TAPE AND REEL BOX DIMENSIONS**

\*All dimensions are nominal

Device	Package Type	Package Drawing	Pins	SPQ	Length (mm)	Width (mm)	Height (mm)
SN74LVC07ADGVR	TVSOP	DGV	14	2000	367.0	367.0	35.0
SN74LVC07ADR	SOIC	D	14	2500	367.0	367.0	38.0
SN74LVC07ADR	SOIC	D	14	2500	364.0	364.0	27.0
SN74LVC07ADR	SOIC	D	14	2500	333.2	345.9	28.6
SN74LVC07ADRG3	SOIC	D	14	2500	364.0	364.0	27.0
SN74LVC07ADRG4	SOIC	D	14	2500	367.0	367.0	38.0
SN74LVC07ADRG4	SOIC	D	14	2500	333.2	345.9	28.6
SN74LVC07ADT	SOIC	D	14	250	210.0	185.0	35.0
SN74LVC07ANSR	SO	NS	14	2000	367.0	367.0	38.0
SN74LVC07APWR	TSSOP	PW	14	2000	367.0	367.0	35.0
SN74LVC07APWRG3	TSSOP	PW	14	2000	364.0	364.0	27.0
SN74LVC07APWRG4	TSSOP	PW	14	2000	367.0	367.0	35.0
SN74LVC07APWT	TSSOP	PW	14	250	367.0	367.0	35.0
SN74LVC07ARGYR	VQFN	RGY	14	3000	367.0	367.0	35.0

DGV (R-PDSO-G\*\*)

PLASTIC SMALL-OUTLINE

24 PINS SHOWN



- NOTES: A. All linear dimensions are in millimeters.  
 B. This drawing is subject to change without notice.  
 C. Body dimensions do not include mold flash or protrusion, not to exceed 0,15 per side.  
 D. Falls within JEDEC: 24/48 Pins – MO-153  
 14/16/20/56 Pins – MO-194

D (R-PDSO-G14)

PLASTIC SMALL OUTLINE

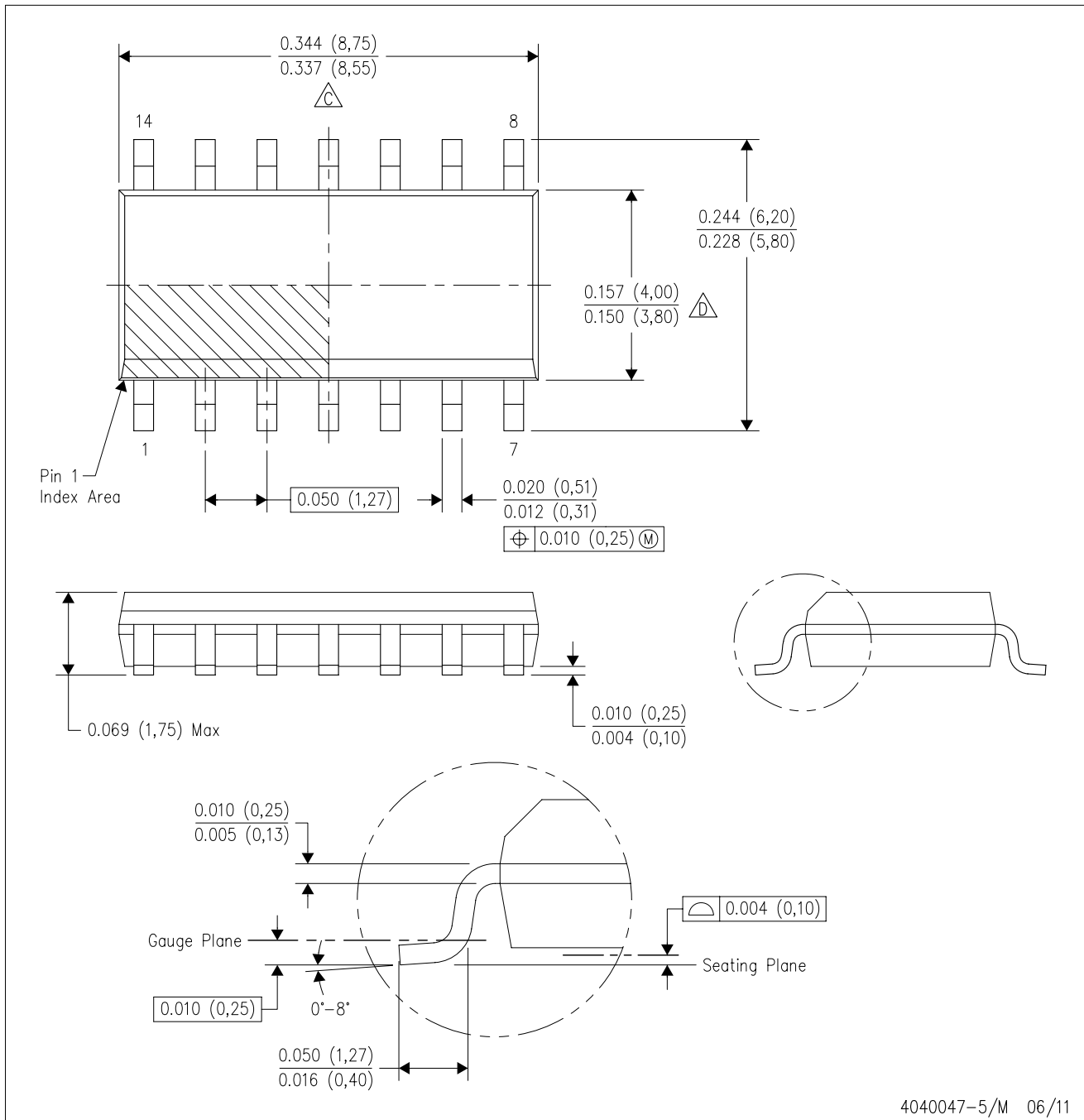

- NOTES:
- A. All linear dimensions are in inches (millimeters).
  - B. This drawing is subject to change without notice.
  - $\triangle C$  Body length does not include mold flash, protrusions, or gate burrs. Mold flash, protrusions, or gate burrs shall not exceed 0.006 (0,15) each side.
  - $\triangle D$  Body width does not include interlead flash. Interlead flash shall not exceed 0.017 (0,43) each side.
  - E. Reference JEDEC MS-012 variation AB.

D (R-PDSO-G14)

PLASTIC SMALL OUTLINE



4211283-3/E 08/12

- NOTES:
- All linear dimensions are in millimeters.
  - This drawing is subject to change without notice.
  - Publication IPC-7351 is recommended for alternate designs.
  - Laser cutting apertures with trapezoidal walls and also rounding corners will offer better paste release. Customers should contact their board assembly site for stencil design recommendations. Refer to IPC-7525 for other stencil recommendations.
  - Customers should contact their board fabrication site for solder mask tolerances between and around signal pads.

PW (R-PDSO-G14)

PLASTIC SMALL OUTLINE

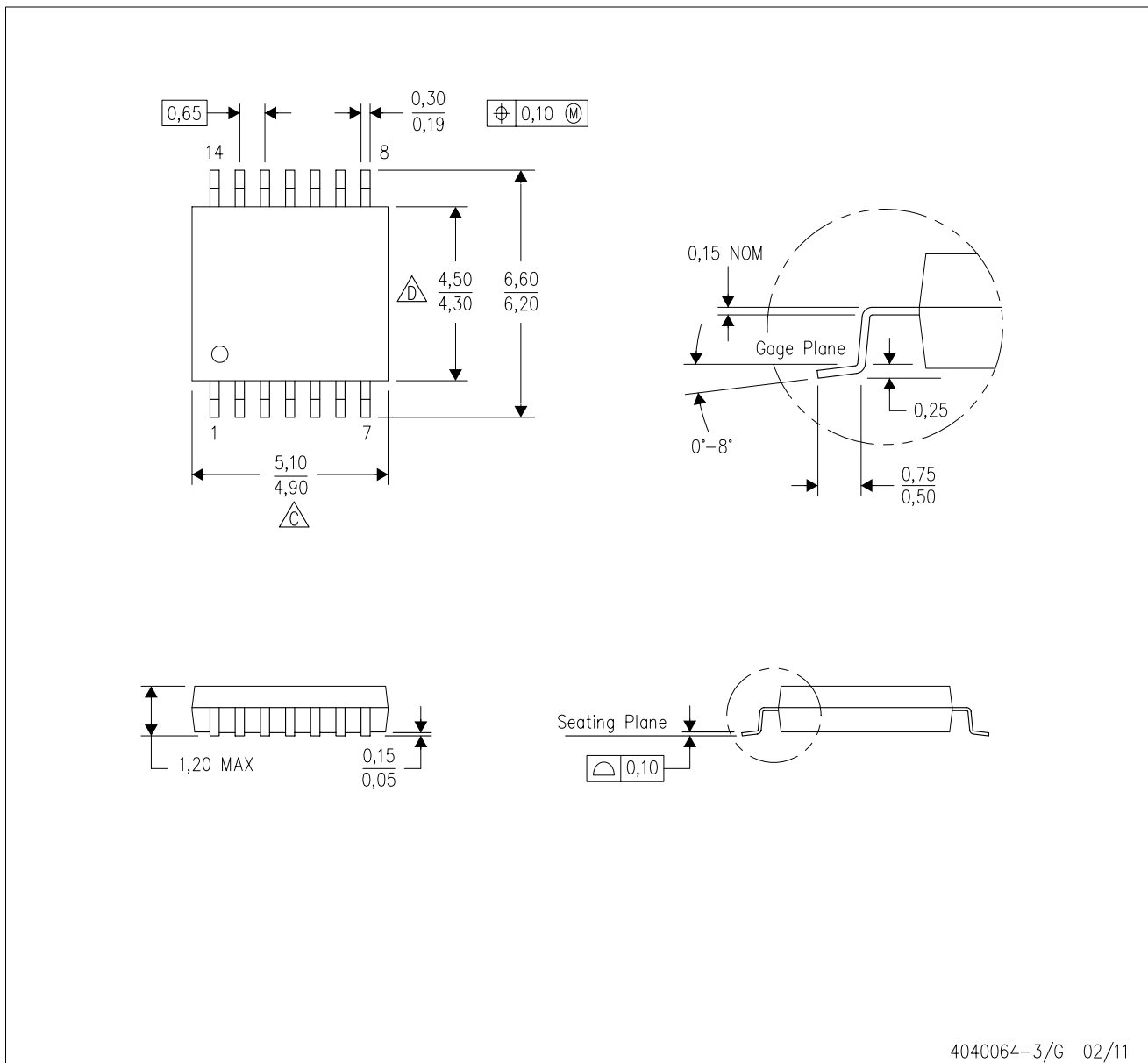

- NOTES:
- A. All linear dimensions are in millimeters. Dimensioning and tolerancing per ASME Y14.5M-1994.
  - B. This drawing is subject to change without notice.
  - C. Body length does not include mold flash, protrusions, or gate burrs. Mold flash, protrusions, or gate burrs shall not exceed 0,15 each side.
  - D. Body width does not include interlead flash. Interlead flash shall not exceed 0,25 each side.
  - E. Falls within JEDEC MO-153

PW (R-PDSO-G14)

PLASTIC SMALL OUTLINE



4211284-2/G 08/15

- NOTES:
- All linear dimensions are in millimeters.
  - This drawing is subject to change without notice.
  - Publication IPC-7351 is recommended for alternate designs.
  - Laser cutting apertures with trapezoidal walls and also rounding corners will offer better paste release. Customers should contact their board assembly site for stencil design recommendations. Refer to IPC-7525 for other stencil recommendations.
  - Customers should contact their board fabrication site for solder mask tolerances between and around signal pads.

RGY (S-PVQFN-N14)

PLASTIC QUAD FLATPACK NO-LEAD



- NOTES:
- A. All linear dimensions are in millimeters. Dimensioning and tolerancing per ASME Y14.5M-1994.
  - B. This drawing is subject to change without notice.
  - C. QFN (Quad Flatpack No-Lead) package configuration.
  - D. The package thermal pad must be soldered to the board for thermal and mechanical performance.
  - E. See the additional figure in the Product Data Sheet for details regarding the exposed thermal pad features and dimensions.
  - F. Pin 1 identifiers are located on both top and bottom of the package and within the zone indicated. The Pin 1 identifiers are either a molded, marked, or metal feature.
  - G. Package complies to JEDEC MO-241 variation BA.

RGY (S-PVQFN-N14)

PLASTIC QUAD FLATPACK NO-LEAD

**THERMAL INFORMATION**

This package incorporates an exposed thermal pad that is designed to be attached directly to an external heatsink. The thermal pad must be soldered directly to the printed circuit board (PCB). After soldering, the PCB can be used as a heatsink. In addition, through the use of thermal vias, the thermal pad can be attached directly to the appropriate copper plane shown in the electrical schematic for the device, or alternatively, can be attached to a special heatsink structure designed into the PCB. This design optimizes the heat transfer from the integrated circuit (IC).

For information on the Quad Flatpack No-Lead (QFN) package and its advantages, refer to Application Report, QFN/SON PCB Attachment, Texas Instruments Literature No. SLUA271. This document is available at [www.ti.com](http://www.ti.com).

The exposed thermal pad dimensions for this package are shown in the following illustration.

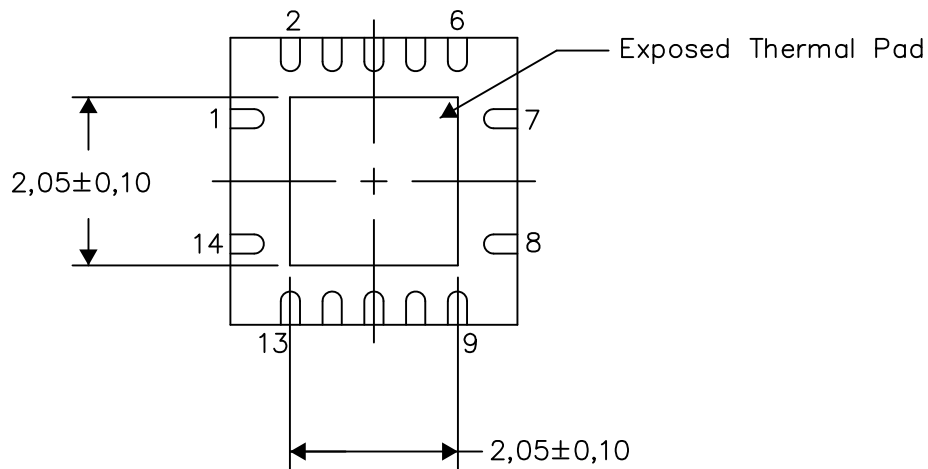

Bottom View

Exposed Thermal Pad Dimensions

4206353-2/P 03/14

NOTE: All linear dimensions are in millimeters

RGY (S-PVQFN-N14)

PLASTIC QUAD FLATPACK NO-LEAD



4208122-2/P 03/14

- NOTES:
- All linear dimensions are in millimeters.
  - This drawing is subject to change without notice.
  - Publication IPC-7351 is recommended for alternate designs.
  - This package is designed to be soldered to a thermal pad on the board. Refer to Application Note, Quad Flat-Pack QFN/SON PCB Attachment, Texas Instruments Literature No. SLUA271, and also the Product Data Sheets for specific thermal information, via requirements, and recommended board layout. These documents are available at [www.ti.com](http://www.ti.com) <<http://www.ti.com>>.
  - Laser cutting apertures with trapezoidal walls and also rounding corners will offer better paste release. Customers should contact their board assembly site for stencil design recommendations. Refer to IPC 7525 for stencil design considerations.
  - Customers should contact their board fabrication site for minimum solder mask web tolerances between signal pads.

# MECHANICAL DATA

NS (R-PDSO-G\*\*)

PLASTIC SMALL-OUTLINE PACKAGE

14-PINS SHOWN



- NOTES:
- A. All linear dimensions are in millimeters.
  - B. This drawing is subject to change without notice.
  - C. Body dimensions do not include mold flash or protrusion, not to exceed 0,15.

DB (R-PDSO-G\*\*)

PLASTIC SMALL-OUTLINE

28 PINS SHOWN



- NOTES: A. All linear dimensions are in millimeters.  
 B. This drawing is subject to change without notice.  
 C. Body dimensions do not include mold flash or protrusion not to exceed 0,15.  
 D. Falls within JEDEC MO-150

## IMPORTANT NOTICE AND DISCLAIMER

TI PROVIDES TECHNICAL AND RELIABILITY DATA (INCLUDING DATASHEETS), DESIGN RESOURCES (INCLUDING REFERENCE DESIGNS), APPLICATION OR OTHER DESIGN ADVICE, WEB TOOLS, SAFETY INFORMATION, AND OTHER RESOURCES "AS IS" AND WITH ALL FAULTS, AND DISCLAIMS ALL WARRANTIES, EXPRESS AND IMPLIED, INCLUDING WITHOUT LIMITATION ANY IMPLIED WARRANTIES OF MERCHANTABILITY, FITNESS FOR A PARTICULAR PURPOSE OR NON-INFRINGEMENT OF THIRD PARTY INTELLECTUAL PROPERTY RIGHTS.

These resources are intended for skilled developers designing with TI products. You are solely responsible for (1) selecting the appropriate TI products for your application, (2) designing, validating and testing your application, and (3) ensuring your application meets applicable standards, and any other safety, security, or other requirements. These resources are subject to change without notice. TI grants you permission to use these resources only for development of an application that uses the TI products described in the resource. Other reproduction and display of these resources is prohibited. No license is granted to any other TI intellectual property right or to any third party intellectual property right. TI disclaims responsibility for, and you will fully indemnify TI and its representatives against, any claims, damages, costs, losses, and liabilities arising out of your use of these resources.

TI's products are provided subject to TI's Terms of Sale ([www.ti.com/legal/termsofsale.html](http://www.ti.com/legal/termsofsale.html)) or other applicable terms available either on [ti.com](http://ti.com) or provided in conjunction with such TI products. TI's provision of these resources does not expand or otherwise alter TI's applicable warranties or warranty disclaimers for TI products.

Mailing Address: Texas Instruments, Post Office Box 655303, Dallas, Texas 75265  
Copyright © 2019, Texas Instruments Incorporated

## Looking for pricing, stock, or lifecycle information?

Click below to explore more details on WIN SOURCE:

 [View SN74LVC07APWRG4 on WIN SOURCE](#)

 [Texas Instruments](#) Information

## Optimize Your Supply Chain with WIN SOURCE Solutions

-  Global Sourcing Solution
-  Obsolete Management
-  Cost Control Management
-  Shortage Management
-  Alternative Solution
-  Excess Inventory Management