



**THE DATASHEET OF  
SN74LVC138ADR**



## SN74LVC138A 3-Line to 8-Line Decoders Demultiplexers

### 1 Features

- Operate From 1.65 V to 3.6 V
- Inputs Accept Voltages to 5.5 V
- Max  $t_{pd}$  of 5.8 ns at 3.3 V
- Typical  $V_{OLP}$  (Output Ground Bounce)  $< 0.8$  V at  $V_{CC} = 3.3$  V,  $T_A = 25^\circ\text{C}$
- Typical  $V_{OHV}$  (Output  $V_{OH}$  Undershoot)  $> 2$  V at  $V_{CC} = 3.3$  V,  $T_A = 25^\circ\text{C}$
- Latch-Up Performance Exceeds 250 mA Per JESD 17

### 2 Applications

- LED Displays
- Servers
- White Goods
- Power Infrastructure
- Building Automation
- Factory Automation

### 3 Description

The SN74LVC138A devices are designed for high-performance memory-decoding or data-routing applications requiring very short propagation delay times. In high-performance memory systems, these decoders minimize the effects of system decoding. When employed with high-speed memories using a fast enable circuit, delay times of these decoders and the enable time of the memory usually are less than the typical access time of the memory. This means that the effective system delay introduced by the decoders is negligible.

Device Information<sup>(1)</sup>

PART NUMBER	PACKAGE	BODY SIZE (NOM)
SNx4LVC138A	LCCC (20)	8.89 mm × 8.89 mm
	CDIP (16)	19.56 mm × 6.92 mm
	CFP (16)	10.30 mm × 6.73 mm
	SOIC (16)	9.90 mm × 3.91 mm
	SSOP (16)	6.20 mm × 5.30 mm
	TVSOP (16)	3.60 mm × 4.40 mm
	BGA MICROSTAR JUNIOR (20)	4.00 mm × 3.00 mm
	TSSOP (16)	5.00 mm × 4.40 mm
	UQFN (16)	2.60 mm × 1.80 mm

(1) For all available packages, see the orderable addendum at the end of the data sheet.

Logic Diagram (Positive Logic)

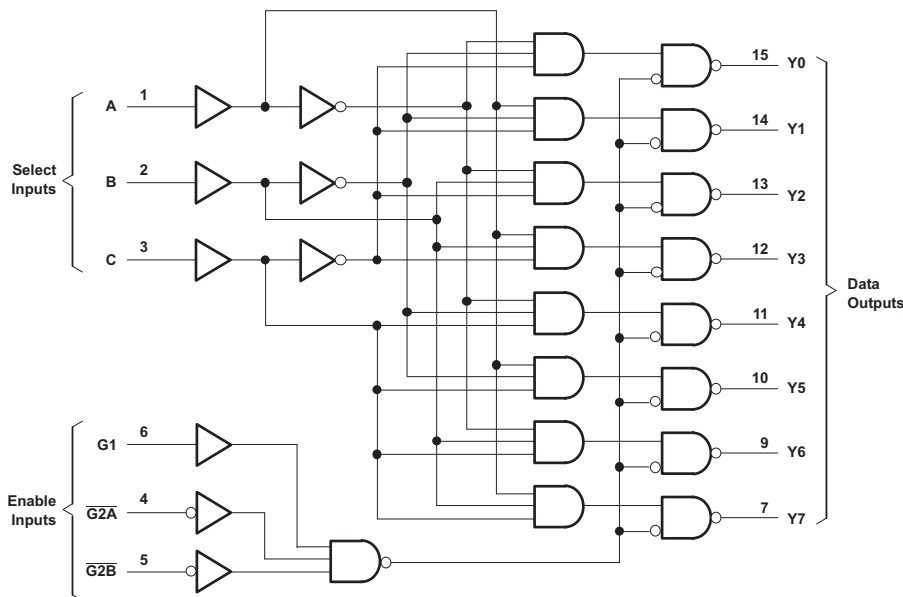

Pin numbers shown are for the D, DB, DGV, J, NS, PW, RGY, and W packages.

Copyright © 2016, Texas Instruments Incorporated



## Table of Contents

<b>1</b>	<b>Features</b> .....	<b>1</b>	8.2	Functional Block Diagram .....	<b>10</b>
<b>2</b>	<b>Applications</b> .....	<b>1</b>	8.3	Feature Description .....	<b>10</b>
<b>3</b>	<b>Description</b> .....	<b>1</b>	8.4	Device Functional Modes .....	<b>11</b>
<b>4</b>	<b>Revision History</b> .....	<b>2</b>	<b>9</b>	<b>Application and Implementation</b> .....	<b>12</b>
<b>5</b>	<b>Pin Configuration and Functions</b> .....	<b>3</b>	9.1	Application Information .....	<b>12</b>
<b>6</b>	<b>Specifications</b> .....	<b>5</b>	9.2	Typical Application .....	<b>12</b>
6.1	Absolute Maximum Ratings .....	<b>5</b>	<b>10</b>	<b>Power Supply Recommendations</b> .....	<b>13</b>
6.2	ESD Ratings .....	<b>5</b>	<b>11</b>	<b>Layout</b> .....	<b>13</b>
6.3	Recommended Operating Conditions .....	<b>6</b>	11.1	Layout Guidelines .....	<b>13</b>
6.4	Thermal Information .....	<b>6</b>	11.2	Layout Example .....	<b>13</b>
6.5	Electrical Characteristics .....	<b>7</b>	<b>12</b>	<b>Device and Documentation Support</b> .....	<b>14</b>
6.6	Switching Characteristics—SN54LVC138A .....	<b>7</b>	12.1	Related Links .....	<b>14</b>
6.7	Switching Characteristics—SN74LVC138A .....	<b>7</b>	12.2	Receiving Notification of Documentation Updates .....	<b>14</b>
6.8	Operating Characteristics .....	<b>8</b>	12.3	Community Resources .....	<b>14</b>
6.9	Typical Characteristics .....	<b>8</b>	12.4	Trademarks .....	<b>14</b>
<b>7</b>	<b>Parameter Measurement Information</b> .....	<b>9</b>	12.5	Electrostatic Discharge Caution .....	<b>14</b>
<b>8</b>	<b>Detailed Description</b> .....	<b>10</b>	12.6	Glossary .....	<b>14</b>
8.1	Overview .....	<b>10</b>	<b>13</b>	<b>Mechanical, Packaging, and Orderable Information</b> .....	<b>14</b>

## 4 Revision History

NOTE: Page numbers for previous revisions may differ from page numbers in the current version.

<b>Changes from Revision V (November 2013) to Revision W</b>	<b>Page</b>
• Added <i>ESD Ratings</i> table, <i>Feature Description</i> section, <i>Device Functional Modes</i> , <i>Application and Implementation</i> section, <i>Power Supply Recommendations</i> section, <i>Layout</i> section, <i>Device and Documentation Support</i> section, and <i>Mechanical, Packaging, and Orderable Information</i> section .....	<b>1</b>
• Deleted <i>Ordering Information</i> table; see <i>Packaging Ordering Addendum</i> at the end of the data sheet .....	<b>1</b>
• Changed R <sub>0JA</sub> values from: 73 to 86.8 (D), 82 to 100.1 (DB), 120 to 122.1 (DGV), 78 to 84 (ZQN), 108 to 108.9 (PW) .....	<b>6</b>
• Deleted R <sub>0JA</sub> values for NS and RGY packages .....	<b>6</b>

<b>Changes from Revision U (OCTOBER 2012) to Revision V</b>	<b>Page</b>
• Updated document to new TI data sheet format - no specification changes .....	<b>1</b>
• Removed <i>Ordering Information</i> table .....	<b>1</b>
• Added ESD warning .....	<b>1</b>

## 5 Pin Configuration and Functions

**SN54LVC138A . . . J OR W PACKAGE  
SN74LVC138A . . . D, DB, DGV, NS,  
OR PW PACKAGE  
(TOP VIEW)**

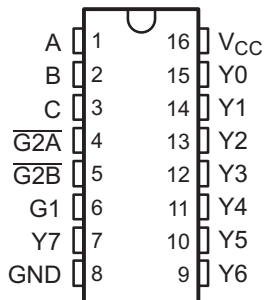

**SN74LVC138A . . . RGY PACKAGE  
(TOP VIEW)**

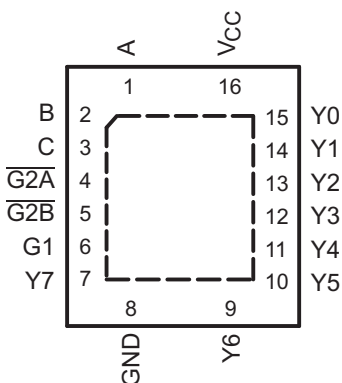

**SN54LVC138A . . . FK PACKAGE  
(TOP VIEW)**

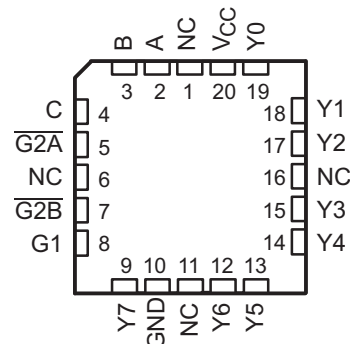

NC - No internal connection

**SN54LVC138A . . . RSV PACKAGE  
(TOP VIEW)**

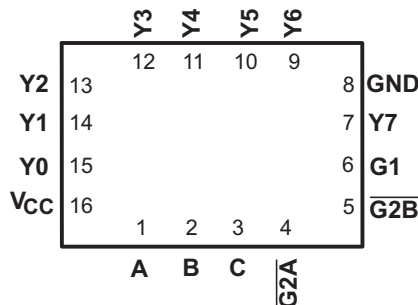

**QQN OR ZQN PACKAGE  
(TOP VIEW)**

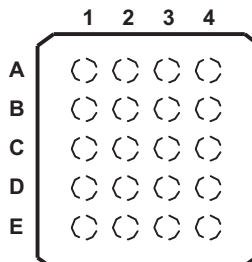

**Table 1. Pin Assignments for ZQN (BGA)**

	1	2	3	4
<b>A</b>	B	A	V <sub>CC</sub>	Y0
<b>B</b>	C	NC <sup>(1)</sup>	NC <sup>(1)</sup>	Y1
<b>C</b>	G2B	G2A	Y3	Y2
<b>D</b>	G1	NC <sup>(1)</sup>	NC <sup>(1)</sup>	Y4
<b>E</b>	GND	Y7	Y6	Y5

(1) NC - No internal connection

**SN54LVC138A, SN74LVC138A**

SCAS291W – MARCH 1993 – REVISED OCTOBER 2016

[www.ti.com](http://www.ti.com)
**Pin Functions**

NAME	PIN				DESCRIPTION
	SOIC, SSOP, TVSOP, SO, TSSOP, VQFN, UQFN	LCCC	BGA MICROSTAR JUNIOR	I/O	
A	1	2	A2	I	Select input A (least significant bit)
B	2	3	A1	I	Select input B
C	3	4	B1	I	Select input C (most significant bit)
$\overline{G}2A$	4	5	C2	I	Active low enable A
$\overline{G}2B$	5	7	C1	I	Active low enable B
G1	6	8	D1	I	Active high enable
GND	8	10	E1	—	Ground
NC	—	1, 11, 16	B2, B3, D2, D3	—	No internal connection
V <sub>CC</sub>	16	20	A3	—	Supply voltage
Y0	15	19	A4	O	Output 0 (least significant bit)
Y1	14	18	B4	O	Output 1
Y2	13	17	C4	O	Output 2
Y3	12	15	C3	O	Output 3
Y4	11	14	D4	O	Output 4
Y5	10	13	E4	O	Output 5
Y6	9	12	E3	O	Output 6
Y7	7	9	E2	O	Output 7 (most significant bit)

## 6 Specifications

### 6.1 Absolute Maximum Ratings

over operating free-air temperature range (unless otherwise noted)<sup>(1)</sup>

		MIN	MAX	UNIT
V <sub>CC</sub>	Supply voltage	-0.5	6.5	V
V <sub>I</sub>	Input voltage <sup>(2)</sup>	-0.5	6.5	V
V <sub>O</sub>	Output voltage <sup>(2)(3)</sup>	-0.5	V <sub>CC</sub> + 0.5	V
I <sub>IK</sub>	Input clamp current	V <sub>I</sub> < 0	-50	mA
I <sub>OK</sub>	Output clamp current	V <sub>O</sub> < 0	-50	mA
I <sub>O</sub>	Continuous output current		±50	mA
	Continuous current through V <sub>CC</sub> or GND		±100	mA
T <sub>stg</sub>	Storage temperature	-65	150	°C
T <sub>J</sub>	Junction temperature		150	°C

- (1) Stresses beyond those listed under *Absolute Maximum Ratings* may cause permanent damage to the device. These are stress ratings only, which do not imply functional operation of the device at these or any other conditions beyond those indicated under *Recommended Operating Conditions*. Exposure to absolute-maximum-rated conditions for extended periods may affect device reliability.
- (2) The input and output negative-voltage ratings may be exceeded if the input and output current ratings are observed.
- (3) The value of V<sub>CC</sub> is provided in the recommended operating conditions table.

### 6.2 ESD Ratings

		VALUE	UNIT
V <sub>(ESD)</sub>	Electrostatic discharge	Human-body model (HBM), per ANSI/ESDA/JEDEC JS-001 <sup>(1)</sup>	2000
		Charged-device model (CDM), per JEDEC specification JESD22-C101 <sup>(2)</sup>	1000
		Machine model (MM)	200

- (1) JEDEC document JEP155 states that 500-V HBM allows safe manufacturing with a standard ESD control process.
- (2) JEDEC document JEP157 states that 250-V CDM allows safe manufacturing with a standard ESD control process.

### 6.3 Recommended Operating Conditions

			MIN	MAX	UNIT	
V <sub>CC</sub>	Supply voltage	Operating	SN54LVC138A <sup>(1)</sup>	2	3.6	V
			SN74LVC138A <sup>(1)</sup>	1.65	3.6	
		Data retention only		1.5		
V <sub>IH</sub>	High-level input voltage	V <sub>CC</sub> = 1.65 V to 1.95 V	SN74LVC138A <sup>(1)</sup>	0.65 × V <sub>CC</sub>		V
		V <sub>CC</sub> = 2.3 V to 2.7 V	SN74LVC138A <sup>(1)</sup>	1.7		
		V <sub>CC</sub> = 2.7 V to 3.6 V		2		
V <sub>IL</sub>	Low-level input voltage	V <sub>CC</sub> = 1.65 V to 1.95 V	SN74LVC138A <sup>(1)</sup>	0.35 × V <sub>CC</sub>		V
		V <sub>CC</sub> = 2.3 V to 2.7 V	SN74LVC138A <sup>(1)</sup>	0.7		
		V <sub>CC</sub> = 2.7 V to 3.6 V		0.8		
V <sub>I</sub>	Input voltage		0	5.5	V	
V <sub>O</sub>	Output voltage		0	V <sub>CC</sub>	V	
I <sub>OH</sub>	High-level output current	V <sub>CC</sub> = 1.65 V	SN74LVC138A <sup>(1)</sup>		–4	mA
		V <sub>CC</sub> = 2.3 V	SN74LVC138A <sup>(1)</sup>		–8	
		V <sub>CC</sub> = 2.7 V			–12	
		V <sub>CC</sub> = 3 V			–24	
I <sub>OL</sub>	Low-level output current	V <sub>CC</sub> = 1.65 V	SN74LVC138A <sup>(1)</sup>		4	mA
		V <sub>CC</sub> = 2.3 V	SN74LVC138A <sup>(1)</sup>		8	
		V <sub>CC</sub> = 2.7 V			12	
		V <sub>CC</sub> = 3 V			24	
Δt/Δv	Input transition rise or fall rate				10	ns/V
T <sub>A</sub>	Operating free-air temperature	SN54LVC138A <sup>(1)</sup>		–55	125	°C
		SN74LVC138A <sup>(1)</sup>		–40	85	

(1) All unused inputs of the device must be held at V<sub>CC</sub> or GND to ensure proper device operation. See the TI application report, [Implications of Slow or Floating CMOS Inputs](#).

### 6.4 Thermal Information

THERMAL METRIC <sup>(1)</sup>	SNx4LVC138A									UNIT	
	FK (LCCC)	J (CDIP)	W (CFP)	D (SOIC)	DB (SSOP)	DGV (TVSOP)	ZQN (BGA MICROSTAR JUNIOR)	PW (TSSOP)	RSV (UQFN)		
	20 PINS	16 PINS	16 PINS	16 PINS	16 PINS	16 PINS	20 PINS	16 PINS	16 PINS		
R <sub>θJA</sub>	Junction-to-ambient thermal resistance	79.2	85.8	138.0	86.8	100.1	122.1	84	108.9	168.9	°C/W
R <sub>θJC(top)</sub>	Junction-to-case (top) thermal resistance	56.5	49.3	74.6	47.9	50.6	47.4	56.9	42.5	78.2	°C/W
R <sub>θJB</sub>	Junction-to-board thermal resistance	55.2	64.9	127.7	43.8	50.7	53.8	46.1	54.5	96.4	°C/W
ψ <sub>JT</sub>	Junction-to-top characterization parameter	49.8	37.4	50	15.7	14.3	4.6	3	4.4	4.2	°C/W
ψ <sub>JB</sub>	Junction-to-board characterization parameter	55.0	69.5	115.7	43.5	50.1	53.2	48.9	53.8	96.5	°C/W

(1) For more information about traditional and new thermal metrics, see the [Semiconductor and IC Package Thermal Metrics](#) application report.

## 6.5 Electrical Characteristics

over recommended operating free-air temperature range (unless otherwise noted)

PARAMETER	TEST CONDITIONS		V <sub>CC</sub>	MIN	TYP <sup>(1)</sup>	MAX	UNIT	
V <sub>OH</sub>	High-level output voltage	I <sub>OH</sub> = -100 μA	SN74LVC138A	1.65 V to 3.6 V	V <sub>CC</sub> - 0.2		V	
			SN54LVC138A	2.7 V to 3.6 V	V <sub>CC</sub> - 0.2			
		I <sub>OH</sub> = -4 mA	SN74LVC138A	1.65 V	1.2			
			SN74LVC138A	2.3 V	1.7			
		I <sub>OH</sub> = -12 mA			2.7 V	2.2		
					3 V	2.4		
V <sub>OL</sub>	Low-level output voltage	I <sub>OL</sub> = 100 μA	SN74LVC138A	1.65 V to 3.6 V	0.2		V	
			SN54LVC138A	2.7 V to 3.6 V	0.2			
		I <sub>OL</sub> = 4 mA	SN74LVC138A	1.65 V	0.45			
			SN74LVC138A	2.3 V	0.7			
		I <sub>OL</sub> = 12 mA			2.7 V	0.4		
					3 V	0.55		
I <sub>I</sub>	Input current	V <sub>I</sub> = 5.5 V or GND	3.6 V	±5		μA		
I <sub>CC</sub>	Supply current	V <sub>I</sub> = V <sub>CC</sub> or GND, I <sub>O</sub> = 0	3.6 V	10		μA		
ΔI <sub>CC</sub>	Change in supply current	One input at V <sub>CC</sub> - 0.6 V, Other inputs at V <sub>CC</sub> or GND	2.7 V to 3.6 V	500		μA		
C <sub>i</sub>	Input capacitance	V <sub>I</sub> = V <sub>CC</sub> or GND	3.3 V	5		pF		

 (1) All typical values are at V<sub>CC</sub> = 3.3 V, T<sub>A</sub> = 25°C.

## 6.6 Switching Characteristics—SN54LVC138A

over recommended operating free-air temperature range (unless otherwise noted) (see Figure 2)

PARAMETER	FROM (INPUT)	TO (OUTPUT)	TEST CONDITIONS	MIN	MAX	UNIT
t <sub>pd</sub>	A or B or C	Y	V <sub>CC</sub> = 2.7 V	7.9		ns
			V <sub>CC</sub> = 3.3 V ± 0.3 V	1	6.7	
	G2A or G2B		V <sub>CC</sub> = 2.7 V	7.4		
			V <sub>CC</sub> = 3.3 V ± 0.3 V	1	6.5	
	G1		V <sub>CC</sub> = 2.7 V	6.4		
			V <sub>CC</sub> = 3.3 V ± 0.3 V	1	5.8	

## 6.7 Switching Characteristics—SN74LVC138A

over recommended operating free-air temperature range (unless otherwise noted) (see Figure 2)

PARAMETER	FROM (INPUT)	TO (OUTPUT)	TEST CONDITIONS	MIN	MAX	UNIT			
t <sub>pd</sub>	A or B or C	Y	V <sub>CC</sub> = 1.8 V ± 0.15 V	1	22	ns			
			V <sub>CC</sub> = 2.5 V ± 0.2 V	1	9.9				
			V <sub>CC</sub> = 2.7 V	1	7.9				
			V <sub>CC</sub> = 3.3 V ± 0.3 V	1	6.7				
			G2A or G2B	V <sub>CC</sub> = 1.8 V ± 0.15 V	1		21		
				V <sub>CC</sub> = 2.5 V ± 0.2 V	1		9.4		
	G1		V <sub>CC</sub> = 2.7 V	1	7.4				
			V <sub>CC</sub> = 3.3 V ± 0.3 V	1	6.5				
			V <sub>CC</sub> = 1.8 V ± 0.15 V	1	20.3				
			V <sub>CC</sub> = 2.5 V ± 0.2 V	1	8.4				
			V <sub>CC</sub> = 2.7 V	1	6.4				
			V <sub>CC</sub> = 3.3 V ± 0.3 V	1	5.8				
	t <sub>sk(o)</sub>		Skew (time), output	—	—		V <sub>CC</sub> = 3.3 V ± 0.3 V	1	ns

### 6.8 Operating Characteristics

T<sub>A</sub> = 25°C

PARAMETER	TEST CONDITIONS	TYP	UNIT
C <sub>pd</sub> Power dissipation capacitance	f = 10 MHz	V <sub>CC</sub> = 1.8 V	25
		V <sub>CC</sub> = 2.5 V	26
		V <sub>CC</sub> = 3.3 V	27

### 6.9 Typical Characteristics

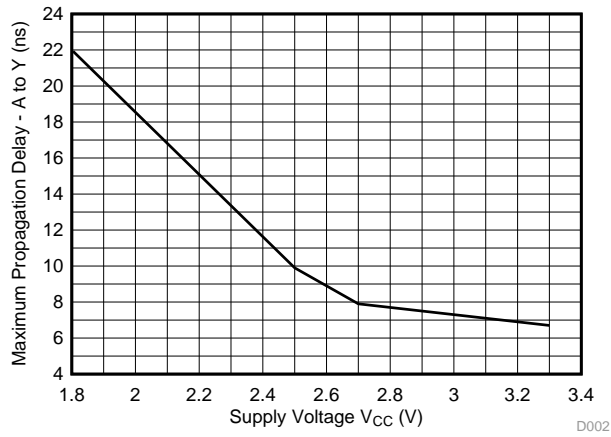
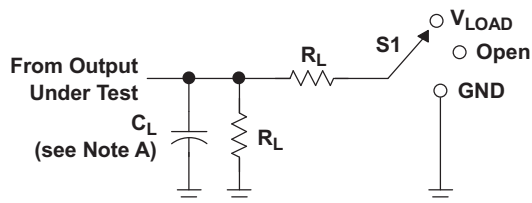

Figure 1. Maximum Propagation Delay vs Supply Voltage D002

## 7 Parameter Measurement Information



LOAD CIRCUIT

TEST	S1
$t_{PLH}/t_{PHL}$	Open
$t_{PLZ}/t_{PZL}$	$V_{LOAD}$
$t_{PHZ}/t_{PZH}$	GND

$V_{CC}$	INPUTS		$V_M$	$V_{LOAD}$	$C_L$	$R_L$	$V_D$
	$V_I$	$t_r/t_f$					
$1.8\text{ V} \pm 0.15\text{ V}$	$V_{CC}$	$\leq 2\text{ ns}$	$V_{CC}/2$	$2 \times V_{CC}$	30 pF	1 kW	0.15 V
$2.5\text{ V} \pm 0.2\text{ V}$	$V_{CC}$	$\leq 2\text{ ns}$	$V_{CC}/2$	$2 \times V_{CC}$	30 pF	500 W	0.15 V
2.7 V	2.7 V	$\leq 2.5\text{ ns}$	1.5 V	6 V	50 pF	500 W	0.3 V
$3.3\text{ V} \pm 0.3\text{ V}$	2.7 V	$\leq 2.5\text{ ns}$	1.5 V	6 V	50 pF	500 W	0.3 V

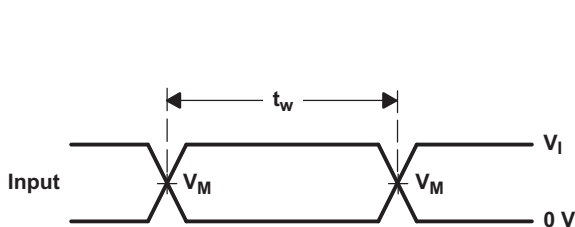

VOLTAGE WAVEFORMS  
PULSE DURATION

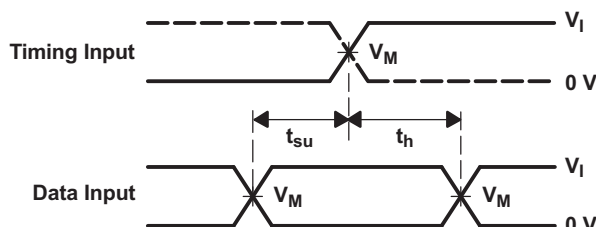

VOLTAGE WAVEFORMS  
SETUP AND HOLD TIMES

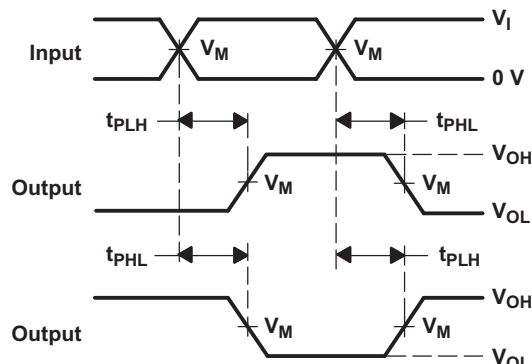

VOLTAGE WAVEFORMS  
PROPAGATION DELAY TIMES  
INVERTING AND NONINVERTING OUTPUTS

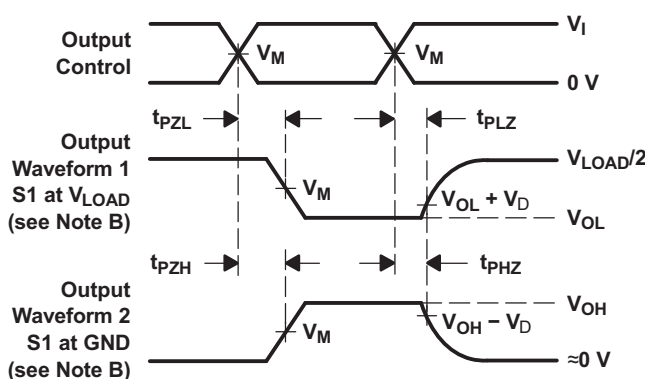

VOLTAGE WAVEFORMS  
ENABLE AND DISABLE TIMES  
LOW- AND HIGH-LEVEL ENABLING

- NOTES:
- A.  $C_L$  includes probe and jig capacitance.
  - B. Waveform 1 is for an output with internal conditions such that the output is low except when disabled by the output control. Waveform 2 is for an output with internal conditions such that the output is high, except when disabled by the output control.
  - C. All input pulses are supplied by generators having the following characteristics:  $PRR \leq 10\text{ MHz}$ ,  $Z_O = 50\ \Omega$ .
  - D. The outputs are measured one at a time, with one transition per measurement.
  - E.  $t_{PLZ}$  and  $t_{PHZ}$  are the same as  $t_{dis}$ .
  - F.  $t_{PZL}$  and  $t_{PZH}$  are the same as  $t_{en}$ .
  - G.  $t_{PLH}$  and  $t_{PHL}$  are the same as  $t_{pd}$ .
  - H. All parameters and waveforms are not applicable to all devices.

Figure 2. Load Circuit and Voltage Waveforms

## 8 Detailed Description

### 8.1 Overview

The SNx4LVC138A devices are 3-to-8 decoders and demultiplexers. The three input pins, A, B, and C, select which output is active. The selected output is pulled LOW, while the remaining outputs are all HIGH. The conditions at the binary-select inputs at the three enable inputs select one of eight output lines. Two active-low and one active-high enable inputs reduce the requirement for external gates or inverters when expanding. A 24-line decoder can be implemented without external inverters, and a 32-line decoder requires only one inverter. An enable input can be used as a data input for demultiplexing applications.

The conditions at the binary-select inputs and the three enable inputs select one of eight output lines. Two active-low enable inputs and one active-high enable input reduce the need for external gates or inverters when expanding. A 24-line decoder can be implemented without external inverters, and a 32-line decoder requires only one inverter. An enable input can be used as a data input for demultiplexing applications.

### 8.2 Functional Block Diagram

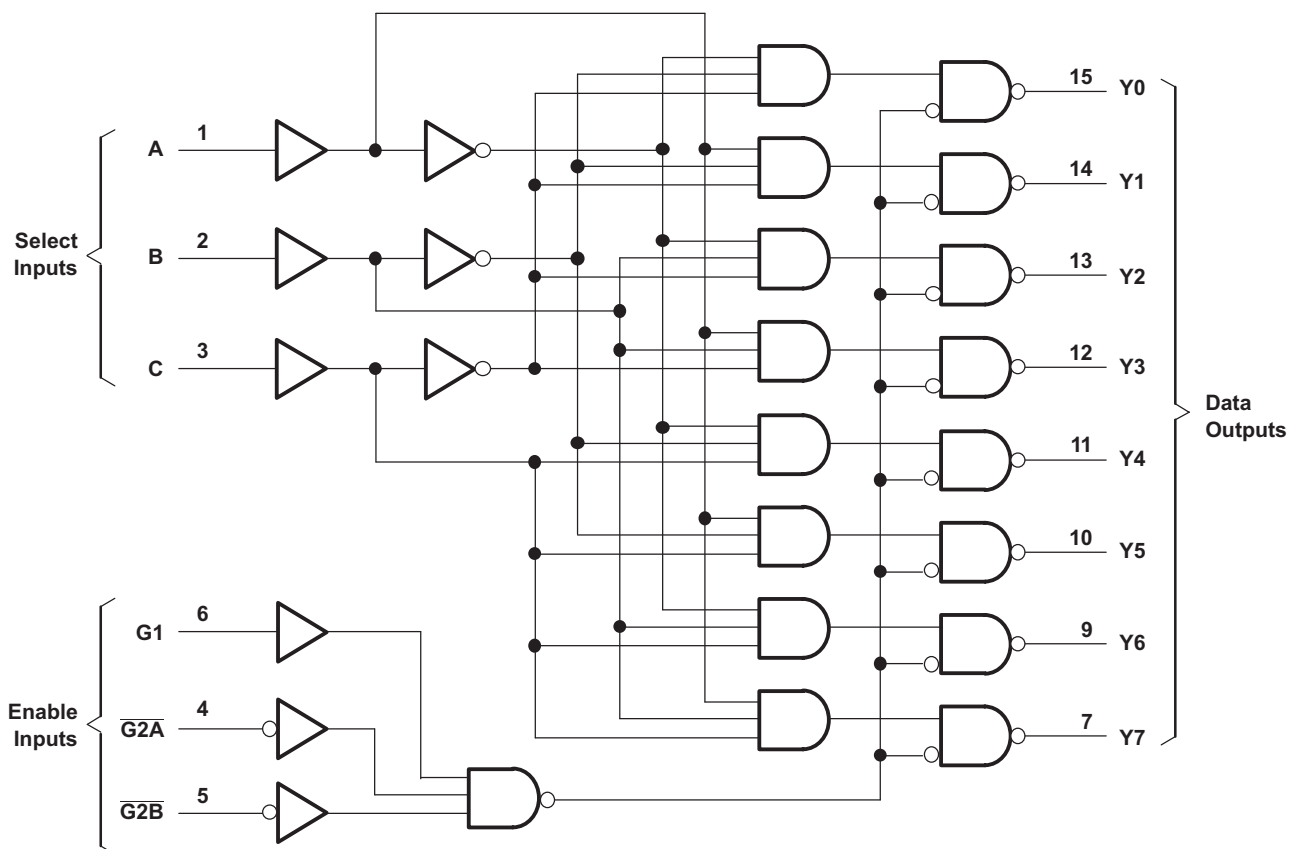

Pin numbers shown are for the D, DB, DGV, J, NS, PW, RGY, and W packages.

Copyright © 2016, Texas Instruments Incorporated

### 8.3 Feature Description

#### 8.3.1 3-Line to 8-Line Decoder

This device features three binary inputs to select a single active-low output. Three enable pins are also available to enable or disable the outputs. One active high enable and two active low enable pins are available, and any enable pin can be deactivated to force all outputs high. All three enable pins must be active for the output to be enabled.

## Feature Description (continued)

### 8.3.2 1.65-V to 3.6-V Operation With Inputs up to 5.5 V

The SN54LVC138A 3-line to 8-line decoder demultiplexer is designed for 2.7-V to 3.6-V  $V_{CC}$  operation, and the SN74LVC138A 3-line to 8-line decoder demultiplexer is designed for 1.65-V to 3.6-V  $V_{CC}$  operation.

Inputs can be driven from either 3.3-V or 5-V devices. This feature allows the use of these devices as translators in a mixed 3.3-V and 5-V system environment.

## 8.4 Device Functional Modes

Table 2 lists the outputs of the SNx4LVC138A devices based on the possible input configurations.

**Table 2. Function Table**

ENABLE INPUTS			SELECT INPUTS			OUTPUTS							
G1	$\overline{G2A}$	$\overline{G2B}$	C	B	A	Y0	Y1	Y2	Y3	Y4	Y5	Y6	Y7
X	H	X	X	X	X	H	H	H	H	H	H	H	H
X	X	H	X	X	X	H	H	H	H	H	H	H	H
L	X	X	X	X	X	H	H	H	H	H	H	H	H
H	L	L	L	L	L	L	H	H	H	H	H	H	H
H	L	L	L	L	H	H	L	H	H	H	H	H	H
H	L	L	L	H	L	H	H	L	H	H	H	H	H
H	L	L	L	H	H	H	H	H	L	H	H	H	H
H	L	L	H	L	L	H	H	H	H	L	H	H	H
H	L	L	H	L	H	H	H	H	H	H	L	H	H
H	L	L	H	H	L	H	H	H	H	H	H	L	H
H	L	L	H	H	H	H	H	H	H	H	H	H	L

## 9 Application and Implementation

### NOTE

Information in the following applications sections is not part of the TI component specification, and TI does not warrant its accuracy or completeness. TI's customers are responsible for determining suitability of components for their purposes. Customers should validate and test their design implementation to confirm system functionality.

### 9.1 Application Information

The SN74LVC138A is useful as a scanning column selector for an LED Matrix display as it can be used for the low-side drive of the LED string. The decoder functionality ensures that no more than one output is pulled to a low-level logic voltage so that only a single column is enabled at any point in time.

### 9.2 Typical Application

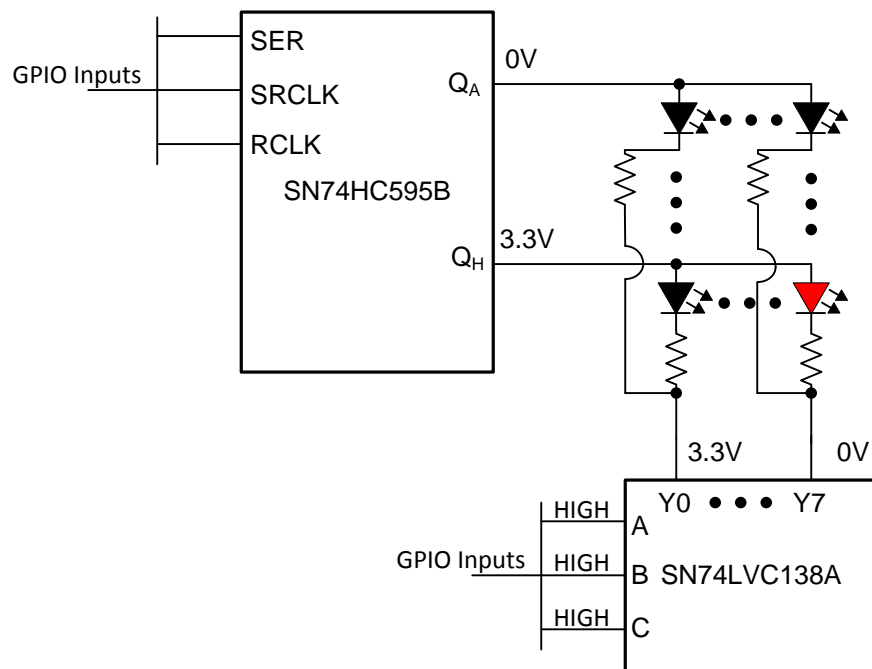

Copyright © 2016, Texas Instruments Incorporated

**Figure 3. LED Matrix Driver Application**

#### 9.2.1 Design Requirements

These devices use CMOS technology and have balanced output drive. Take care to avoid bus contention because it can drive currents that would exceed maximum limits. The high drive also creates fast edges into light loads, so routing and load conditions must be considered to prevent ringing.

#### 9.2.2 Detailed Design Procedure

1. Recommended Input Conditions
  - For switch time specifications, see propagation delay times in [Switching Characteristics—SN74LVC138A](#).
  - For input voltage level specifications for control inputs, see  $V_{IH}$  and  $V_{IL}$  in [Recommended Operating Conditions](#).
2. Recommended Output Conditions
  - Outputs must not be pulled above  $V_{CC}$  or below GND.

## Typical Application (continued)

### 9.2.3 Application Curve

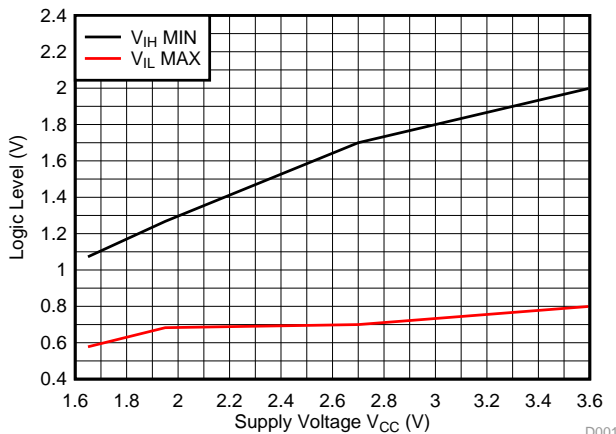

Figure 4. Input High and Input Low Thresholds vs Supply Voltage

## 10 Power Supply Recommendations

The power supply can be any voltage between the minimum and maximum supply voltage rating located in the [Recommended Operating Conditions](#).

Each  $V_{CC}$  terminal must have a good bypass capacitor to prevent power disturbance. A 0.1- $\mu$ F bypass capacitor is recommended to be placed close to the  $V_{CC}$  terminal. It is acceptable to parallel multiple bypass capacitors to reject different frequencies of noise; 0.1- $\mu$ F and 1- $\mu$ F capacitors are commonly used in parallel. The bypass capacitor must be installed as close to the power terminal as possible for best results.

## 11 Layout

### 11.1 Layout Guidelines

Reflections and matching are closely related to loop antenna theory, but different enough to warrant their own discussion. When a PCB trace turns a corner at a 90° angle, a reflection can occur. This is primarily due to the change of width of the trace. At the apex of the turn, the trace width is increased to 1.414 times its width. This upsets the transmission line characteristics, especially the distributed capacitance and self-inductance of the trace (resulting in the reflection). It is a given that not all PCB traces can be straight, and so they have to turn corners. [Figure 5](#) shows progressively better techniques of rounding corners. Only the last example maintains constant trace width and minimizes reflections.

### 11.2 Layout Example

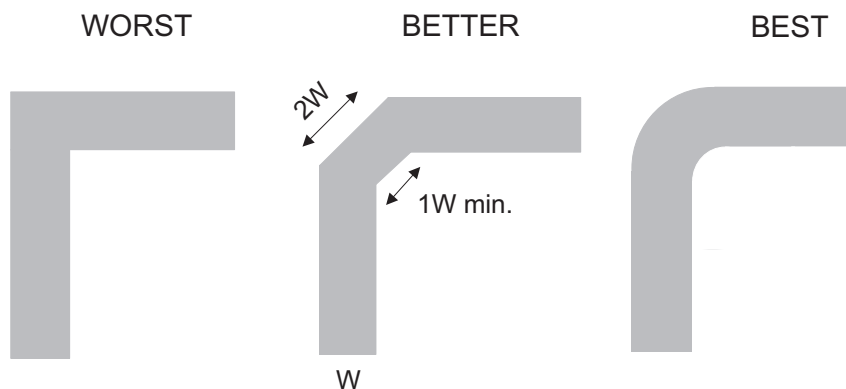

Figure 5. Trace Example

## 12 Device and Documentation Support

### 12.1 Related Links

The table below lists quick access links. Categories include technical documents, support and community resources, tools and software, and quick access to sample or buy.

**Table 3. Related Links**

PARTS	PRODUCT FOLDER	SAMPLE & BUY	TECHNICAL DOCUMENTS	TOOLS & SOFTWARE	SUPPORT & COMMUNITY
SN54LVC138A	<a href="#">Click here</a>	<a href="#">Click here</a>	<a href="#">Click here</a>	<a href="#">Click here</a>	<a href="#">Click here</a>
SN74LVC138A	<a href="#">Click here</a>	<a href="#">Click here</a>	<a href="#">Click here</a>	<a href="#">Click here</a>	<a href="#">Click here</a>

### 12.2 Receiving Notification of Documentation Updates

To receive notification of documentation updates, navigate to the device product folder on ti.com. In the upper right corner, click on *Alert me* to register and receive a weekly digest of any product information that has changed. For change details, review the revision history included in any revised document.

### 12.3 Community Resources

The following links connect to TI community resources. Linked contents are provided "AS IS" by the respective contributors. They do not constitute TI specifications and do not necessarily reflect TI's views; see TI's [Terms of Use](#).

**TI E2E™ Online Community** *TI's Engineer-to-Engineer (E2E) Community*. Created to foster collaboration among engineers. At e2e.ti.com, you can ask questions, share knowledge, explore ideas and help solve problems with fellow engineers.

**Design Support** *TI's Design Support* Quickly find helpful E2E forums along with design support tools and contact information for technical support.

### 12.4 Trademarks

E2E is a trademark of Texas Instruments.  
All other trademarks are the property of their respective owners.

### 12.5 Electrostatic Discharge Caution



These devices have limited built-in ESD protection. The leads should be shorted together or the device placed in conductive foam during storage or handling to prevent electrostatic damage to the MOS gates.

### 12.6 Glossary

[SLYZ022](#) — *TI Glossary*.

This glossary lists and explains terms, acronyms, and definitions.

## 13 Mechanical, Packaging, and Orderable Information

The following pages include mechanical, packaging, and orderable information. This information is the most current data available for the designated devices. This data is subject to change without notice and revision of this document. For browser-based versions of this data sheet, refer to the left-hand navigation.

**PACKAGING INFORMATION**

Orderable Device	Status (1)	Package Type	Package Drawing	Pins	Package Qty	Eco Plan (2)	Lead/Ball Finish (6)	MSL Peak Temp (3)	Op Temp (°C)	Device Marking (4/5)	Samples
5962-9752601Q2A	ACTIVE	LCCC	FK	20	1	TBD	POST-PLATE	N / A for Pkg Type	-55 to 125	5962- 9752601Q2A SNJ54LVC 138AFK	<a href="#">Samples</a>
5962-9752601QEA	ACTIVE	CDIP	J	16	1	TBD	A42	N / A for Pkg Type	-55 to 125	5962-9752601QE A SNJ54LVC138AJ	<a href="#">Samples</a>
5962-9752601QFA	ACTIVE	CFP	W	16	1	TBD	A42	N / A for Pkg Type	-55 to 125	5962-9752601QF A SNJ54LVC138AW	<a href="#">Samples</a>
5962-9752601VFA	ACTIVE	CFP	W	16	1	TBD	A42	N / A for Pkg Type	-55 to 125	5962-9752601VF A SNV54LVC138AW	<a href="#">Samples</a>
SN74LVC138AD	ACTIVE	SOIC	D	16	40	Green (RoHS & no Sb/Br)	CU NIPDAU	Level-1-260C-UNLIM	-40 to 85	LVC138A	<a href="#">Samples</a>
SN74LVC138ADBR	ACTIVE	SSOP	DB	16	2000	Green (RoHS & no Sb/Br)	CU NIPDAU	Level-1-260C-UNLIM	-40 to 85	LC138A	<a href="#">Samples</a>
SN74LVC138ADE4	ACTIVE	SOIC	D	16	40	Green (RoHS & no Sb/Br)	CU NIPDAU	Level-1-260C-UNLIM	-40 to 85	LVC138A	<a href="#">Samples</a>
SN74LVC138ADGVR	ACTIVE	TVSOP	DGV	16	2000	Green (RoHS & no Sb/Br)	CU NIPDAU	Level-1-260C-UNLIM	-40 to 85	LC138A	<a href="#">Samples</a>
SN74LVC138ADR	ACTIVE	SOIC	D	16	2500	Green (RoHS & no Sb/Br)	CU NIPDAU	Level-1-260C-UNLIM	-40 to 85	LVC138A	<a href="#">Samples</a>
SN74LVC138ADRE4	ACTIVE	SOIC	D	16	2500	Green (RoHS & no Sb/Br)	CU NIPDAU	Level-1-260C-UNLIM	-40 to 85	LVC138A	<a href="#">Samples</a>
SN74LVC138ADRG4	ACTIVE	SOIC	D	16	2500	Green (RoHS & no Sb/Br)	CU NIPDAU	Level-1-260C-UNLIM	-40 to 85	LVC138A	<a href="#">Samples</a>
SN74LVC138ADT	ACTIVE	SOIC	D	16	250	Green (RoHS & no Sb/Br)	CU NIPDAU	Level-1-260C-UNLIM	-40 to 85	LVC138A	<a href="#">Samples</a>
SN74LVC138ANSR	ACTIVE	SO	NS	16	2000	Green (RoHS & no Sb/Br)	CU NIPDAU	Level-1-260C-UNLIM	-40 to 85	LVC138A	<a href="#">Samples</a>
SN74LVC138ANSRG4	ACTIVE	SO	NS	16	2000	Green (RoHS & no Sb/Br)	CU NIPDAU	Level-1-260C-UNLIM	-40 to 85	LVC138A	<a href="#">Samples</a>
SN74LVC138APW	ACTIVE	TSSOP	PW	16	90	Green (RoHS & no Sb/Br)	CU NIPDAU	Level-1-260C-UNLIM	-40 to 85	LC138A	<a href="#">Samples</a>

Orderable Device	Status (1)	Package Type	Package Drawing	Pins	Package Qty	Eco Plan (2)	Lead/Ball Finish (6)	MSL Peak Temp (3)	Op Temp (°C)	Device Marking (4/5)	Samples
SN74LVC138APWE4	ACTIVE	TSSOP	PW	16	90	Green (RoHS & no Sb/Br)	CU NIPDAU	Level-1-260C-UNLIM	-40 to 85	LC138A	<a href="#">Samples</a>
SN74LVC138APWG4	ACTIVE	TSSOP	PW	16	90	Green (RoHS & no Sb/Br)	CU NIPDAU	Level-1-260C-UNLIM	-40 to 85	LC138A	<a href="#">Samples</a>
SN74LVC138APWR	ACTIVE	TSSOP	PW	16	2000	Green (RoHS & no Sb/Br)	CU NIPDAU   CU SN	Level-1-260C-UNLIM	-40 to 85	LC138A	<a href="#">Samples</a>
SN74LVC138APWRE4	ACTIVE	TSSOP	PW	16	2000	Green (RoHS & no Sb/Br)	CU NIPDAU	Level-1-260C-UNLIM	-40 to 85	LC138A	<a href="#">Samples</a>
SN74LVC138APWRG4	ACTIVE	TSSOP	PW	16	2000	Green (RoHS & no Sb/Br)	CU NIPDAU	Level-1-260C-UNLIM	-40 to 85	LC138A	<a href="#">Samples</a>
SN74LVC138APWT	ACTIVE	TSSOP	PW	16	250	Green (RoHS & no Sb/Br)	CU NIPDAU	Level-1-260C-UNLIM	-40 to 85	LC138A	<a href="#">Samples</a>
SN74LVC138ARGYR	ACTIVE	VQFN	RGY	16	3000	Green (RoHS & no Sb/Br)	CU NIPDAU	Level-2-260C-1 YEAR	-40 to 85	LC138A	<a href="#">Samples</a>
SN74LVC138ARGYRG4	ACTIVE	VQFN	RGY	16	3000	Green (RoHS & no Sb/Br)	CU NIPDAU	Level-2-260C-1 YEAR	-40 to 85	LC138A	<a href="#">Samples</a>
SN74LVC138ARSVR	ACTIVE	UQFN	RSV	16	3000	Green (RoHS & no Sb/Br)	CU NIPDAU	Level-1-260C-UNLIM	-40 to 85	ZTP	<a href="#">Samples</a>
SN74LVC138AZQNR	ACTIVE	BGA MICROSTAR JUNIOR	ZQN	20	1000	Green (RoHS & no Sb/Br)	SNAGCU	Level-1-260C-UNLIM	-40 to 85	LC138A	<a href="#">Samples</a>
SNJ54LVC138AFK	ACTIVE	LCCC	FK	20	1	TBD	POST-PLATE	N / A for Pkg Type	-55 to 125	5962-9752601Q2A SNJ54LVC138AFK	<a href="#">Samples</a>
SNJ54LVC138AJ	ACTIVE	CDIP	J	16	1	TBD	A42	N / A for Pkg Type	-55 to 125	5962-9752601QE A SNJ54LVC138AJ	<a href="#">Samples</a>
SNJ54LVC138AW	ACTIVE	CFP	W	16	1	TBD	A42	N / A for Pkg Type	-55 to 125	5962-9752601QF A SNJ54LVC138AW	<a href="#">Samples</a>

(1) The marketing status values are defined as follows:

**ACTIVE:** Product device recommended for new designs.

**LIFEBUY:** TI has announced that the device will be discontinued, and a lifetime-buy period is in effect.

**NRND:** Not recommended for new designs. Device is in production to support existing customers, but TI does not recommend using this part in a new design.

**PREVIEW:** Device has been announced but is not in production. Samples may or may not be available.

**OBSELETE:** TI has discontinued the production of the device.

(2) **RoHS:** TI defines "RoHS" to mean semiconductor products that are compliant with the current EU RoHS requirements for all 10 RoHS substances, including the requirement that RoHS substance do not exceed 0.1% by weight in homogeneous materials. Where designed to be soldered at high temperatures, "RoHS" products are suitable for use in specified lead-free processes. TI may reference these types of products as "Pb-Free".

**RoHS Exempt:** TI defines "RoHS Exempt" to mean products that contain lead but are compliant with EU RoHS pursuant to a specific EU RoHS exemption.

**Green:** TI defines "Green" to mean the content of Chlorine (Cl) and Bromine (Br) based flame retardants meet JS709B low halogen requirements of  $\leq 1000$ ppm threshold. Antimony trioxide based flame retardants must also meet the  $\leq 1000$ ppm threshold requirement.

(3) **MSL, Peak Temp.** - The Moisture Sensitivity Level rating according to the JEDEC industry standard classifications, and peak solder temperature.

(4) There may be additional marking, which relates to the logo, the lot trace code information, or the environmental category on the device.

(5) Multiple Device Markings will be inside parentheses. Only one Device Marking contained in parentheses and separated by a "-" will appear on a device. If a line is indented then it is a continuation of the previous line and the two combined represent the entire Device Marking for that device.

(6) **Lead/Ball Finish** - Orderable Devices may have multiple material finish options. Finish options are separated by a vertical ruled line. Lead/Ball Finish values may wrap to two lines if the finish value exceeds the maximum column width.

**Important Information and Disclaimer:** The information provided on this page represents TI's knowledge and belief as of the date that it is provided. TI bases its knowledge and belief on information provided by third parties, and makes no representation or warranty as to the accuracy of such information. Efforts are underway to better integrate information from third parties. TI has taken and continues to take reasonable steps to provide representative and accurate information but may not have conducted destructive testing or chemical analysis on incoming materials and chemicals. TI and TI suppliers consider certain information to be proprietary, and thus CAS numbers and other limited information may not be available for release.

In no event shall TI's liability arising out of such information exceed the total purchase price of the TI part(s) at issue in this document sold by TI to Customer on an annual basis.

**OTHER QUALIFIED VERSIONS OF SN54LVC138A, SN54LVC138A-SP, SN74LVC138A :**

- Catalog: [SN74LVC138A](#), [SN54LVC138A](#)
  
- Automotive: [SN74LVC138A-Q1](#), [SN74LVC138A-Q1](#)
  
- Enhanced Product: [SN74LVC138A-EP](#), [SN74LVC138A-EP](#)
  
- Military: [SN54LVC138A](#)
  
- Space: [SN54LVC138A-SP](#)

NOTE: Qualified Version Definitions:

- Catalog - TI's standard catalog product
- Automotive - Q100 devices qualified for high-reliability automotive applications targeting zero defects
- Enhanced Product - Supports Defense, Aerospace and Medical Applications
- Military - QML certified for Military and Defense Applications
- Space - Radiation tolerant, ceramic packaging and qualified for use in Space-based application

## TAPE AND REEL INFORMATION



### QUADRANT ASSIGNMENTS FOR PIN 1 ORIENTATION IN TAPE



\*All dimensions are nominal

Device	Package Type	Package Drawing	Pins	SPQ	Reel Diameter (mm)	Reel Width W1 (mm)	A0 (mm)	B0 (mm)	K0 (mm)	P1 (mm)	W (mm)	Pin1 Quadrant
SN74LVC138ADGVR	TVSOP	DGV	16	2000	330.0	12.4	6.8	4.0	1.6	8.0	12.0	Q1
SN74LVC138ADR	SOIC	D	16	2500	330.0	16.4	6.5	10.3	2.1	8.0	16.0	Q1
SN74LVC138APWR	TSSOP	PW	16	2000	330.0	12.4	6.9	5.6	1.6	8.0	12.0	Q1
SN74LVC138APWR	TSSOP	PW	16	2000	330.0	12.4	6.9	5.6	1.6	8.0	12.0	Q1
SN74LVC138APWRG4	TSSOP	PW	16	2000	330.0	12.4	6.9	5.6	1.6	8.0	12.0	Q1
SN74LVC138APWT	TSSOP	PW	16	250	330.0	12.4	6.9	5.6	1.6	8.0	12.0	Q1
SN74LVC138ARGYR	VQFN	RGY	16	3000	330.0	12.4	3.8	4.3	1.5	8.0	12.0	Q1
SN74LVC138AZQNR	BGA MICROSTAR JUNIOR	ZQN	20	1000	330.0	12.4	3.3	4.3	1.6	8.0	12.0	Q1

**TAPE AND REEL BOX DIMENSIONS**

\*All dimensions are nominal

Device	Package Type	Package Drawing	Pins	SPQ	Length (mm)	Width (mm)	Height (mm)
SN74LVC138ADGVR	TVSOP	DGV	16	2000	367.0	367.0	35.0
SN74LVC138ADR	SOIC	D	16	2500	333.2	345.9	28.6
SN74LVC138APWR	TSSOP	PW	16	2000	364.0	364.0	27.0
SN74LVC138APWR	TSSOP	PW	16	2000	367.0	367.0	35.0
SN74LVC138APWRG4	TSSOP	PW	16	2000	367.0	367.0	35.0
SN74LVC138APWT	TSSOP	PW	16	250	367.0	367.0	35.0
SN74LVC138ARGYR	VQFN	RGY	16	3000	367.0	367.0	35.0
SN74LVC138AZQNR	BGA MICROSTAR JUNIOR	ZQN	20	1000	350.0	350.0	43.0

ZQN (R-PBGA-N20)

PLASTIC BALL GRID ARRAY

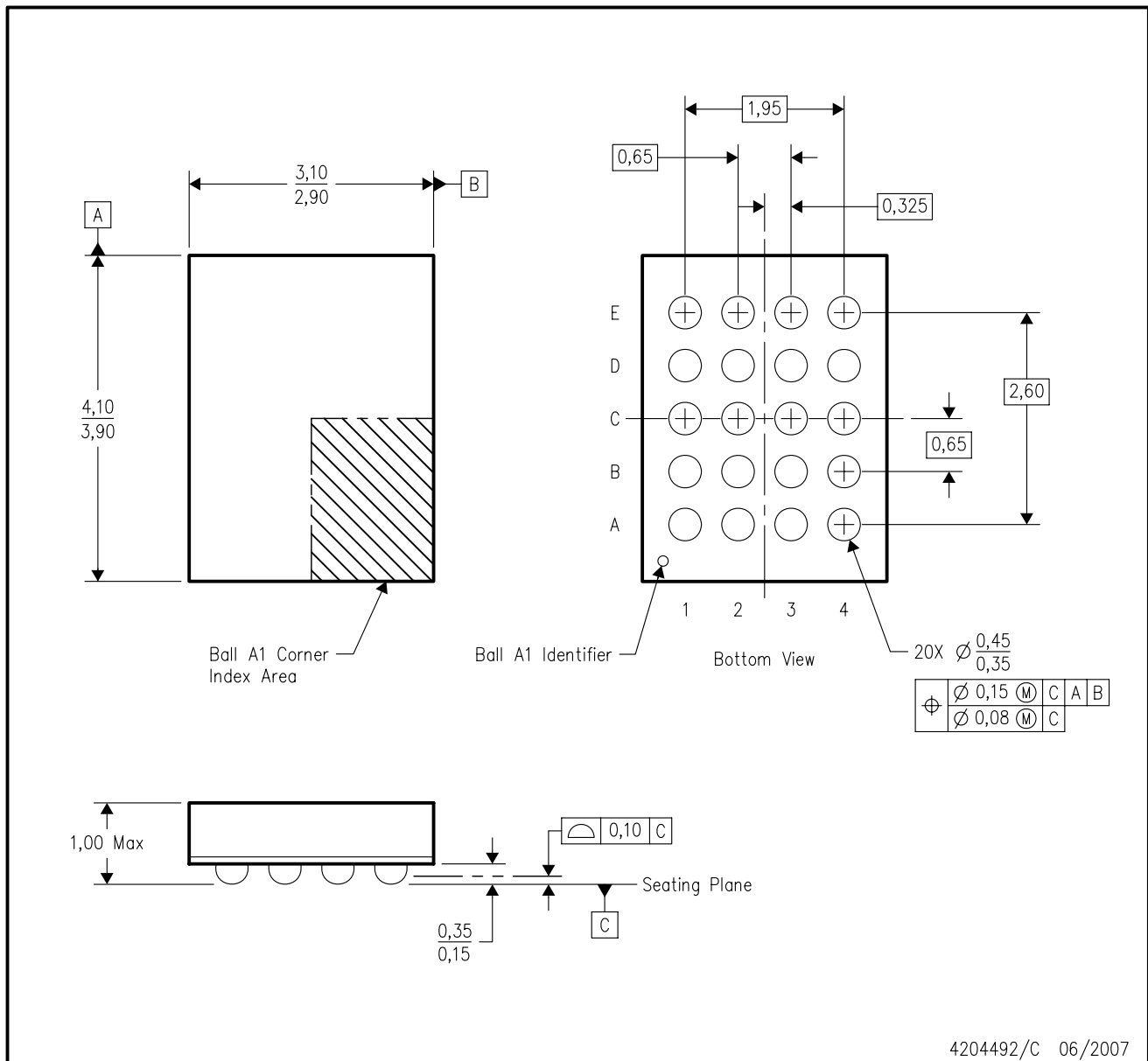

- NOTES:
- A. All linear dimensions are in millimeters. Dimensioning and tolerancing per ASME Y14.5M-1994.
  - B. This drawing is subject to change without notice.
  - C. Falls within JEDEC MO-285 variation BC-2.
  - D. This package is lead-free. Refer to the 20 GQN package (drawing 4200704) for tin-lead (SnPb).

DGV (R-PDSO-G\*\*)

PLASTIC SMALL-OUTLINE

24 PINS SHOWN



- NOTES: A. All linear dimensions are in millimeters.  
 B. This drawing is subject to change without notice.  
 C. Body dimensions do not include mold flash or protrusion, not to exceed 0,15 per side.  
 D. Falls within JEDEC: 24/48 Pins – MO-153  
 14/16/20/56 Pins – MO-194

RGY (R-PVQFN-N16)

PLASTIC QUAD FLATPACK NO-LEAD



4203539-3/1 06/2011

- NOTES:
- All linear dimensions are in millimeters. Dimensioning and tolerancing per ASME Y14.5M-1994.
  - This drawing is subject to change without notice.
  - QFN (Quad Flatpack No-Lead) package configuration.
  - The package thermal pad must be soldered to the board for thermal and mechanical performance.
  - See the additional figure in the Product Data Sheet for details regarding the exposed thermal pad features and dimensions.
  - Pin 1 identifiers are located on both top and bottom of the package and within the zone indicated. The Pin 1 identifiers are either a molded, marked, or metal feature.
  - Package complies to JEDEC MO-241 variation BA.

RGY (R-PVQFN-N16)

PLASTIC QUAD FLATPACK NO-LEAD

**THERMAL INFORMATION**

This package incorporates an exposed thermal pad that is designed to be attached directly to an external heatsink. The thermal pad must be soldered directly to the printed circuit board (PCB). After soldering, the PCB can be used as a heatsink. In addition, through the use of thermal vias, the thermal pad can be attached directly to the appropriate copper plane shown in the electrical schematic for the device, or alternatively, can be attached to a special heatsink structure designed into the PCB. This design optimizes the heat transfer from the integrated circuit (IC).

For information on the Quad Flatpack No-Lead (QFN) package and its advantages, refer to Application Report, QFN/SON PCB Attachment, Texas Instruments Literature No. SLUA271. This document is available at [www.ti.com](http://www.ti.com).

The exposed thermal pad dimensions for this package are shown in the following illustration.



Bottom View

Exposed Thermal Pad Dimensions

4206353-3/P 03/14

NOTE: All linear dimensions are in millimeters

RGY (R-PVQFN-N16)

PLASTIC QUAD FLATPACK NO-LEAD



4208122-3/P 03/14

- NOTES:
- A. All linear dimensions are in millimeters.
  - B. This drawing is subject to change without notice.
  - C. Publication IPC-7351 is recommended for alternate designs.
  - D. This package is designed to be soldered to a thermal pad on the board. Refer to Application Note, Quad Flat-Pack QFN/SON PCB Attachment, Texas Instruments Literature No. SLUA271, and also the Product Data Sheets for specific thermal information, via requirements, and recommended board layout. These documents are available at [www.ti.com](http://www.ti.com) <<http://www.ti.com>>.
  - E. Laser cutting apertures with trapezoidal walls and also rounding corners will offer better paste release. Customers should contact their board assembly site for stencil design recommendations. Refer to IPC 7525 for stencil design considerations.
  - F. Customers should contact their board fabrication site for minimum solder mask web tolerances between signal pads.

FK (S-CQCC-N\*\*)

LEADLESS CERAMIC CHIP CARRIER

28 TERMINAL SHOWN



NO. OF TERMINALS **	A		B	
	MIN	MAX	MIN	MAX
20	0.342 (8,69)	0.358 (9,09)	0.307 (7,80)	0.358 (9,09)
28	0.442 (11,23)	0.458 (11,63)	0.406 (10,31)	0.458 (11,63)
44	0.640 (16,26)	0.660 (16,76)	0.495 (12,58)	0.560 (14,22)
52	0.740 (18,78)	0.761 (19,32)	0.495 (12,58)	0.560 (14,22)
68	0.938 (23,83)	0.962 (24,43)	0.850 (21,6)	0.858 (21,8)
84	1.141 (28,99)	1.165 (29,59)	1.047 (26,6)	1.063 (27,0)



4040140/D 01/11

- NOTES:
- All linear dimensions are in inches (millimeters).
  - This drawing is subject to change without notice.
  - This package can be hermetically sealed with a metal lid.
  - Falls within JEDEC MS-004



D (R-PDSO-G16)

PLASTIC SMALL OUTLINE



- NOTES:
- All linear dimensions are in millimeters.
  - This drawing is subject to change without notice.
  - Publication IPC-7351 is recommended for alternate designs.
  - Laser cutting apertures with trapezoidal walls and also rounding corners will offer better paste release. Customers should contact their board assembly site for stencil design recommendations. Refer to IPC-7525 for other stencil recommendations.
  - Customers should contact their board fabrication site for solder mask tolerances between and around signal pads.



4220204/A 02/2017

**NOTES:**

1. All linear dimensions are in millimeters. Any dimensions in parenthesis are for reference only. Dimensioning and tolerancing per ASME Y14.5M.
2. This drawing is subject to change without notice.
3. This dimension does not include mold flash, protrusions, or gate burrs. Mold flash, protrusions, or gate burrs shall not exceed 0.15 mm per side.
4. This dimension does not include interlead flash. Interlead flash shall not exceed 0.25 mm per side.
5. Reference JEDEC registration MO-153.

# EXAMPLE BOARD LAYOUT

PW0016A

TSSOP - 1.2 mm max height

SMALL OUTLINE PACKAGE



LAND PATTERN EXAMPLE  
EXPOSED METAL SHOWN  
SCALE: 10X



SOLDER MASK DETAILS

4220204/A 02/2017

NOTES: (continued)

- 6. Publication IPC-7351 may have alternate designs.
- 7. Solder mask tolerances between and around signal pads can vary based on board fabrication site.

# EXAMPLE STENCIL DESIGN

PW0016A

TSSOP - 1.2 mm max height

SMALL OUTLINE PACKAGE



SOLDER PASTE EXAMPLE  
BASED ON 0.125 mm THICK STENCIL  
SCALE: 10X

4220204/A 02/2017

NOTES: (continued)

8. Laser cutting apertures with trapezoidal walls and rounded corners may offer better paste release. IPC-7525 may have alternate design recommendations.
9. Board assembly site may have different recommendations for stencil design.

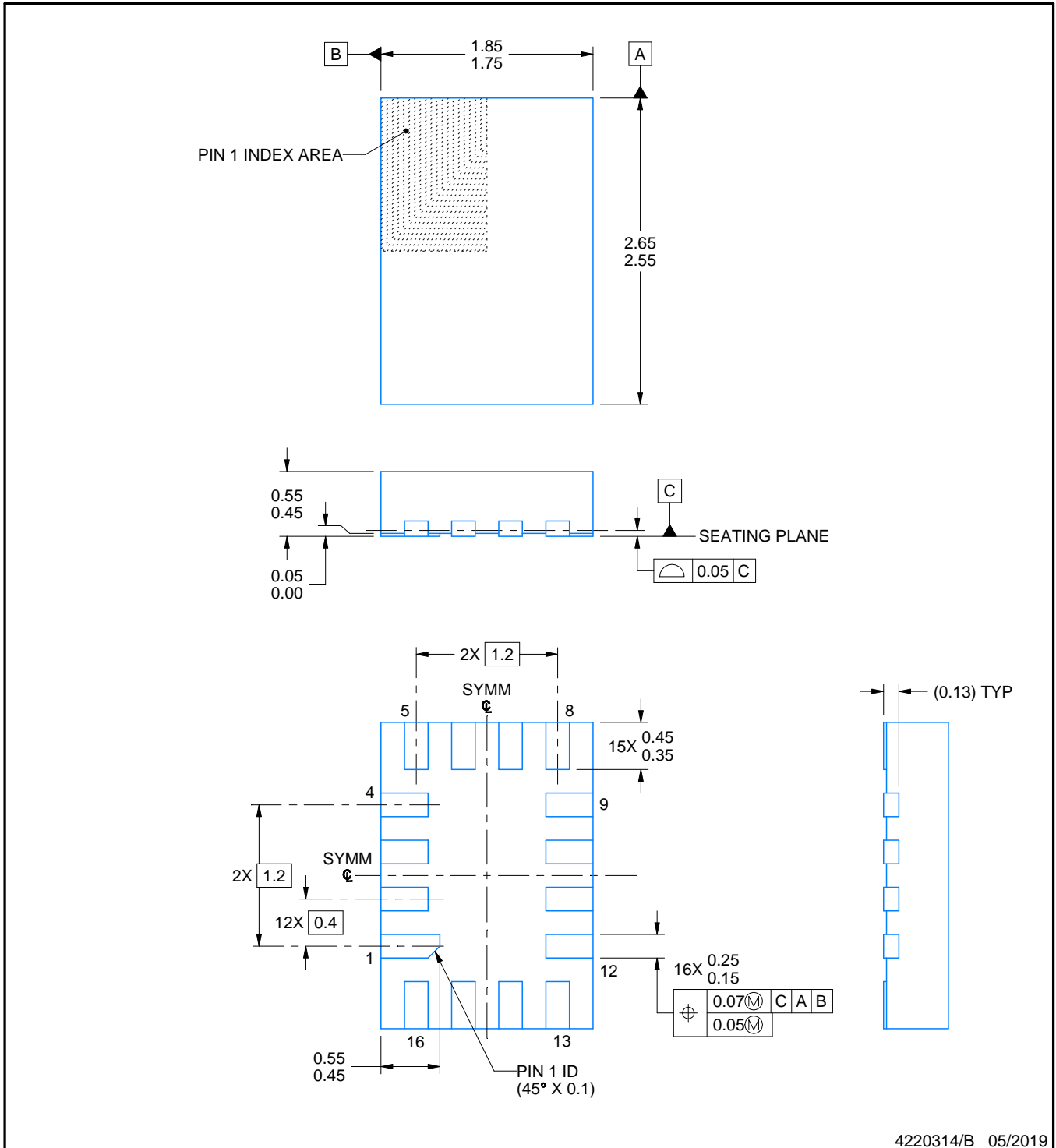
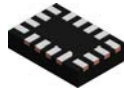

4220314/B 05/2019

NOTES:

1. All linear dimensions are in millimeters. Any dimensions in parenthesis are for reference only. Dimensioning and tolerancing per ASME Y14.5M.
2. This drawing is subject to change without notice.

# EXAMPLE BOARD LAYOUT

RSV0016A

UQFN - 0.55 mm max height

ULTRA THIN QUAD FLATPACK - NO LEAD

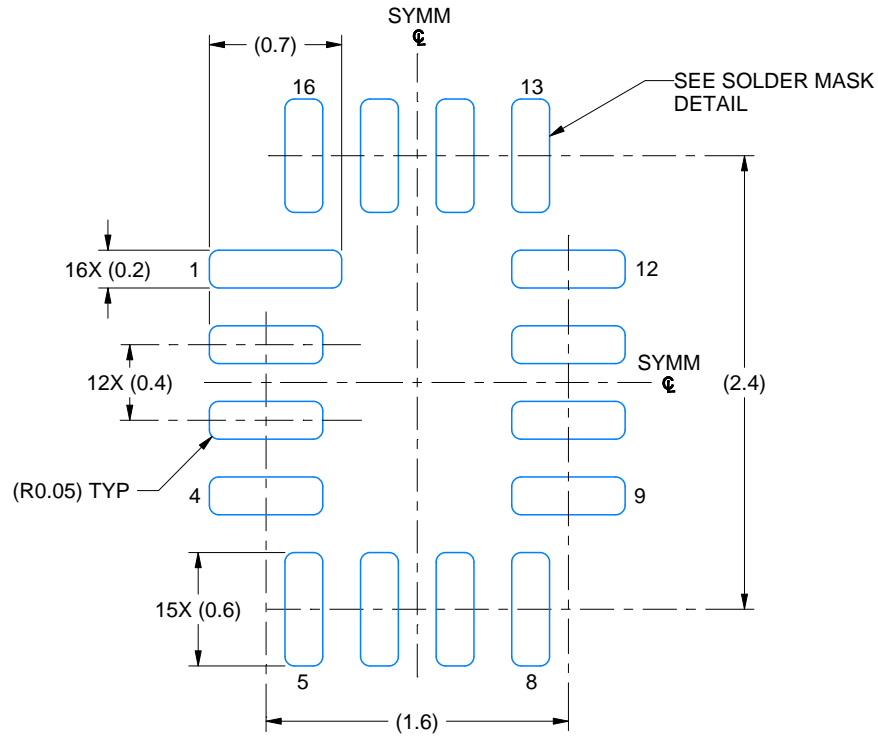

LAND PATTERN EXAMPLE  
EXPOSED METAL SHOWN  
SCALE: 25X

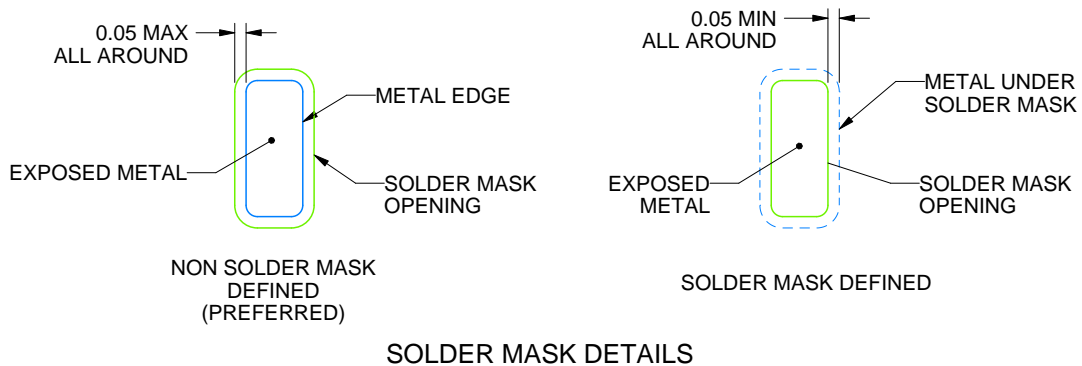

4220314/B 05/2019

NOTES: (continued)

- This package is designed to be soldered to a thermal pad on the board. For more information, see Texas Instruments literature number SLUA271 ([www.ti.com/lit/slua271](http://www.ti.com/lit/slua271)).

# EXAMPLE STENCIL DESIGN

RSV0016A

UQFN - 0.55 mm max height

ULTRA THIN QUAD FLATPACK - NO LEAD

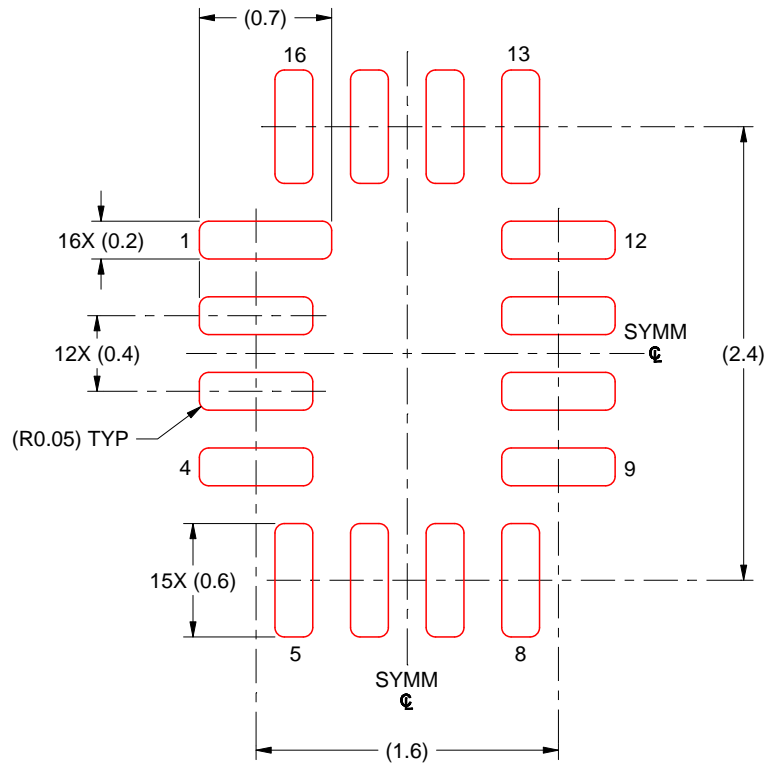

SOLDER PASTE EXAMPLE  
BASED ON 0.125 MM THICK STENCIL  
SCALE: 25X

4220314/B 05/2019

NOTES: (continued)

4. Laser cutting apertures with trapezoidal walls and rounded corners may offer better paste release. IPC-7525 may have alternate design recommendations.

# MECHANICAL DATA

NS (R-PDSO-G\*\*)

PLASTIC SMALL-OUTLINE PACKAGE

14-PINS SHOWN



- NOTES:
- A. All linear dimensions are in millimeters.
  - B. This drawing is subject to change without notice.
  - C. Body dimensions do not include mold flash or protrusion, not to exceed 0,15.

W (R-GDFP-F16)

CERAMIC DUAL FLATPACK

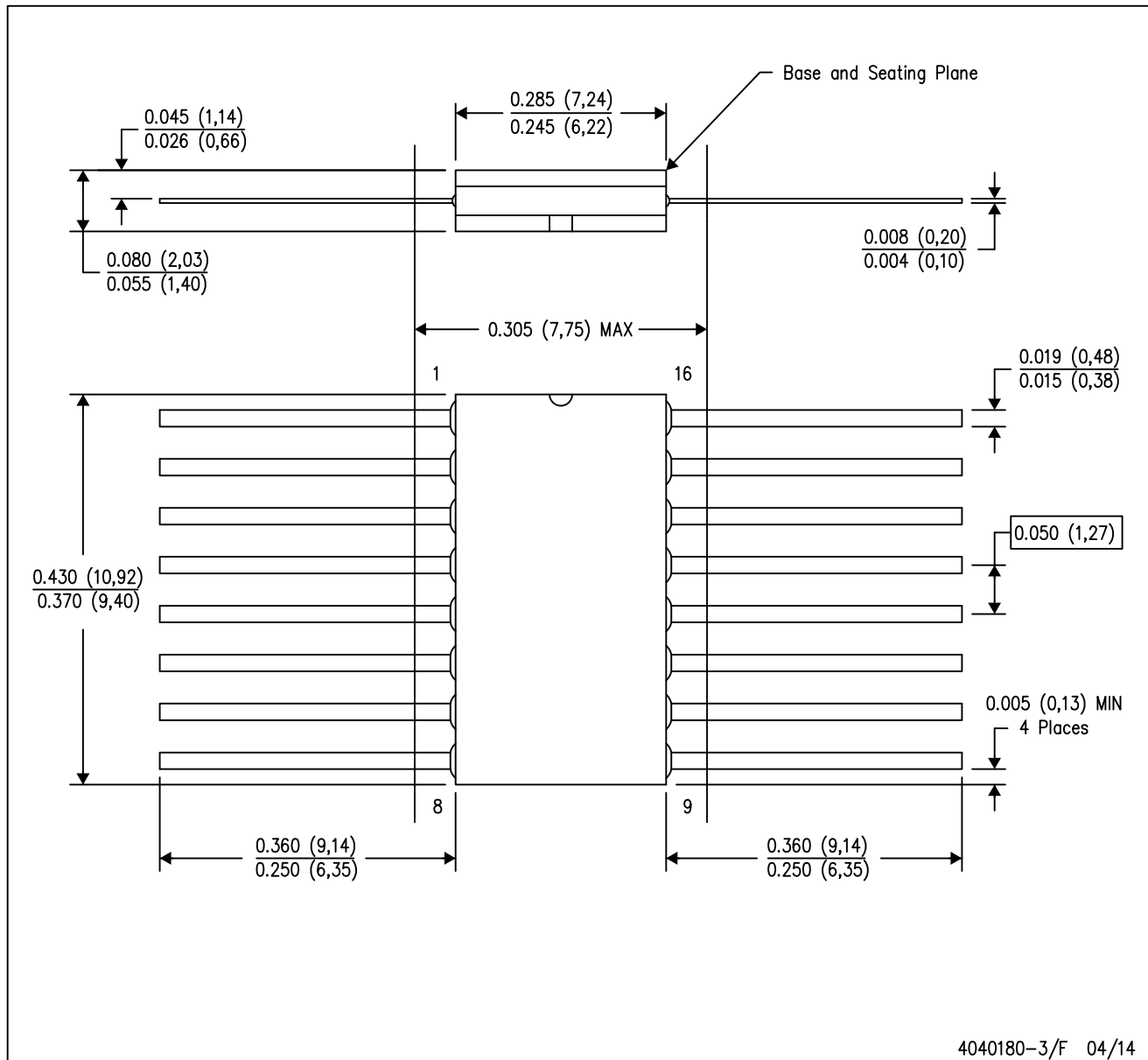

- NOTES:
- A. All linear dimensions are in inches (millimeters).
  - B. This drawing is subject to change without notice.
  - C. This package can be hermetically sealed with a ceramic lid using glass frit.
  - D. Index point is provided on cap for terminal identification only.
  - E. Falls within MIL STD 1835 GDFP2-F16

J (R-GDIP-T\*\*)

14 LEADS SHOWN

CERAMIC DUAL IN-LINE PACKAGE

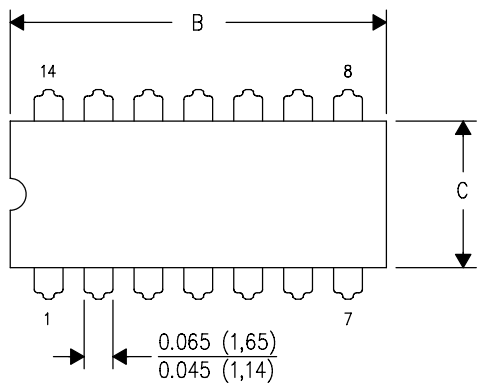

DIM \ PINS **	14	16	18	20
A	0.300 (7,62) BSC	0.300 (7,62) BSC	0.300 (7,62) BSC	0.300 (7,62) BSC
B MAX	0.785 (19,94)	.840 (21,34)	0.960 (24,38)	1.060 (26,92)
B MIN	—	—	—	—
C MAX	0.300 (7,62)	0.300 (7,62)	0.310 (7,87)	0.300 (7,62)
C MIN	0.245 (6,22)	0.245 (6,22)	0.220 (5,59)	0.245 (6,22)

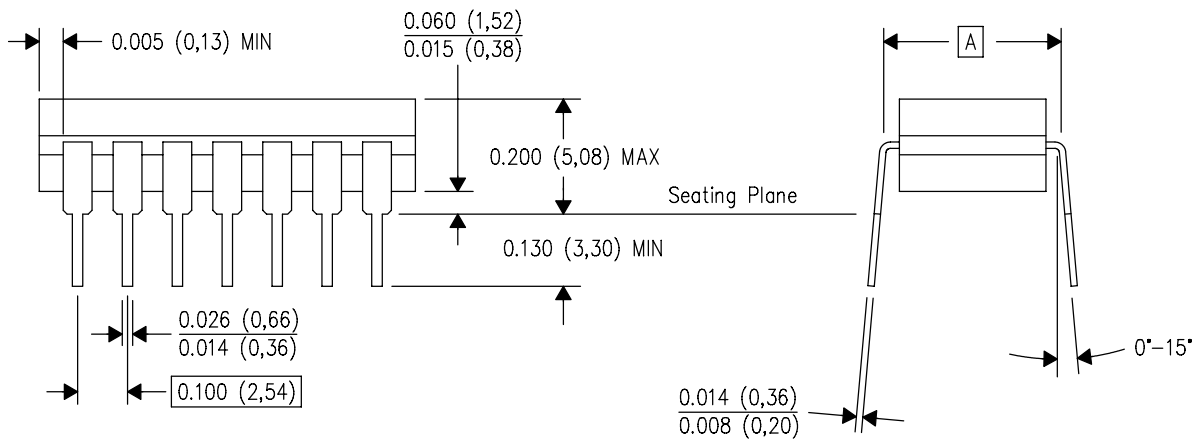

4040083/F 03/03

- NOTES:
- All linear dimensions are in inches (millimeters).
  - This drawing is subject to change without notice.
  - This package is hermetically sealed with a ceramic lid using glass frit.
  - Index point is provided on cap for terminal identification only on press ceramic glass frit seal only.
  - Falls within MIL STD 1835 GDIP1-T14, GDIP1-T16, GDIP1-T18 and GDIP1-T20.

DB (R-PDSO-G\*\*)

PLASTIC SMALL-OUTLINE

28 PINS SHOWN



4040065 /E 12/01

- NOTES: A. All linear dimensions are in millimeters.  
 B. This drawing is subject to change without notice.  
 C. Body dimensions do not include mold flash or protrusion not to exceed 0,15.  
 D. Falls within JEDEC MO-150

## IMPORTANT NOTICE AND DISCLAIMER

TI PROVIDES TECHNICAL AND RELIABILITY DATA (INCLUDING DATASHEETS), DESIGN RESOURCES (INCLUDING REFERENCE DESIGNS), APPLICATION OR OTHER DESIGN ADVICE, WEB TOOLS, SAFETY INFORMATION, AND OTHER RESOURCES "AS IS" AND WITH ALL FAULTS, AND DISCLAIMS ALL WARRANTIES, EXPRESS AND IMPLIED, INCLUDING WITHOUT LIMITATION ANY IMPLIED WARRANTIES OF MERCHANTABILITY, FITNESS FOR A PARTICULAR PURPOSE OR NON-INFRINGEMENT OF THIRD PARTY INTELLECTUAL PROPERTY RIGHTS.

These resources are intended for skilled developers designing with TI products. You are solely responsible for (1) selecting the appropriate TI products for your application, (2) designing, validating and testing your application, and (3) ensuring your application meets applicable standards, and any other safety, security, or other requirements. These resources are subject to change without notice. TI grants you permission to use these resources only for development of an application that uses the TI products described in the resource. Other reproduction and display of these resources is prohibited. No license is granted to any other TI intellectual property right or to any third party intellectual property right. TI disclaims responsibility for, and you will fully indemnify TI and its representatives against, any claims, damages, costs, losses, and liabilities arising out of your use of these resources.

TI's products are provided subject to TI's Terms of Sale ([www.ti.com/legal/termsofsale.html](http://www.ti.com/legal/termsofsale.html)) or other applicable terms available either on [ti.com](http://ti.com) or provided in conjunction with such TI products. TI's provision of these resources does not expand or otherwise alter TI's applicable warranties or warranty disclaimers for TI products.

Mailing Address: Texas Instruments, Post Office Box 655303, Dallas, Texas 75265  
Copyright © 2019, Texas Instruments Incorporated

## Looking for pricing, stock, or lifecycle information?

Click below to explore more details on WIN SOURCE:

 [View SN74LVC138ADR on WIN SOURCE](#)

 [Texas Instruments](#) Information

## Optimize Your Supply Chain with WIN SOURCE Solutions

-  Global Sourcing Solution
-  Obsolete Management
-  Cost Control Management
-  Shortage Management
-  Alternative Solution
-  Excess Inventory Management