



**THE DATASHEET OF  
SN751177N**



# SN751177, SN751178 DUAL DIFFERENTIAL DRIVERS AND RECEIVERS

SLLS059D – FEBRUARY 1990 – REVISED MAY 1999

- Meet or Exceed the Requirements of ANSI Standards TIA/EIA-422-B and TIA/EIA-485-A and ITU Recommendations V.10 and V.11
- Designed for Multipoint Bus Transmission on Long Bus Lines in Noise Environments
- Driver Positive- and Negative-Current Limiting
- Thermal Shutdown Protection
- Driver 3-State Outputs
- Receiver Common-Mode Input Voltage Range of  $-12\text{ V}$  to  $12\text{ V}$
- Receiver Input Sensitivity . . .  $\pm 200\text{ mV}$
- Receiver Hysteresis . . .  $50\text{ mV Typ}$
- Receiver Input Impedance . . .  $12\text{ k}\Omega\text{ Min}$
- Receiver 3-State Outputs (SN751177 Only)
- Operate From Single 5-V Supply

## description

The SN751177 and SN751178 dual differential drivers and receivers are monolithic integrated circuits that are designed for balanced multipoint bus transmission at rates up to 10 Mbit/s. They are designed to improve the performance of full-duplex data communications over long bus lines and meet ANSI Standards TIA/EIA-422-B and TIA/EIA-485-A and ITU Recommendations V.10 and V.11.

The SN751177 and SN751178 driver outputs provide limiting for both positive and negative currents and thermal-shutdown protection from line-fault conditions on the transmission bus line.

The receiver features high input impedance of at least  $12\text{ k}\Omega$ , an input sensitivity of  $\pm 200\text{ mV}$  over a common-mode input voltage range of  $-12\text{ V}$  to  $12\text{ V}$ , and typical input hysteresis of  $50\text{ mV}$ . Fail-safe design ensures that if the receiver inputs are open, the receiver outputs always will be high.

The SN751177 and SN751178 are characterized for operation from  $-20^\circ\text{C}$  to  $85^\circ\text{C}$ .

SN751177 . . . N OR NS† PACKAGE  
(TOP VIEW)

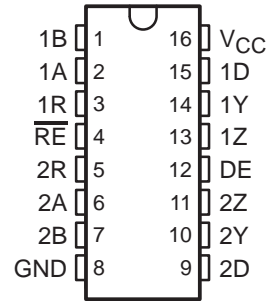

SN751178 . . . N OR NS† PACKAGE  
(TOP VIEW)

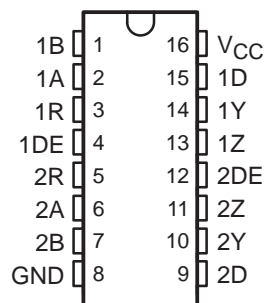

† The NS package is only available taped and reeled.



Please be aware that an important notice concerning availability, standard warranty, and use in critical applications of Texas Instruments semiconductor products and disclaimers thereto appears at the end of this data sheet.

PRODUCTION DATA information is current as of publication date. Products conform to specifications per the terms of Texas Instruments standard warranty. Production processing does not necessarily include testing of all parameters.

 **TEXAS  
INSTRUMENTS**

POST OFFICE BOX 655303 • DALLAS, TEXAS 75265

Copyright © 1999, Texas Instruments Incorporated

# SN751177, SN751178 DUAL DIFFERENTIAL DRIVERS AND RECEIVERS

SLLS059D – FEBRUARY 1990 – REVISED MAY 1999

## Function Tables

**SN751177, SN751178**  
(each driver)

INPUT D	ENABLE DE	OUTPUTS	
		Y	Z
H	H	H	L
L	H	L	H
X	L	Z	Z

H = high level, L = low level, X = irrelevant,  
Z = high impedance (off)

**SN751177**  
(each receiver)

DIFFERENTIAL INPUTS A – B	ENABLE RE	OUTPUT R
$V_{ID} \geq 0.2 V$	L	H
$-0.2 V < V_{ID} < 0.2 V$	L	?
$V_{ID} \leq -0.2 V$	L	L
X	H	Z
Open	L	H

H = high level, L = low level, ? = indeterminate,  
X = irrelevant, Z = high impedance (off)

**SN751178**  
(each receiver)

DIFFERENTIAL INPUTS A – B	OUTPUT R
$V_{ID} \geq 0.2 V$	H
$-0.2 V < V_{ID} < 0.2 V$	?
$V_{ID} \leq -0.2 V$	L

H = high level, L = low level,  
? = indeterminate

# SN751177, SN751178 DUAL DIFFERENTIAL DRIVERS AND RECEIVERS

SLLS059D – FEBRUARY 1990 – REVISED MAY 1999

## logic symbols†

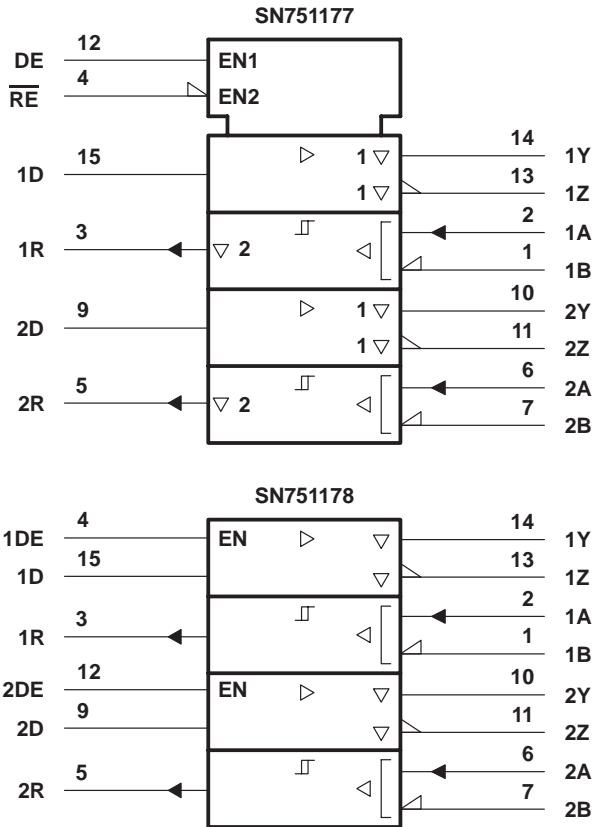

## logic diagrams (positive logic)

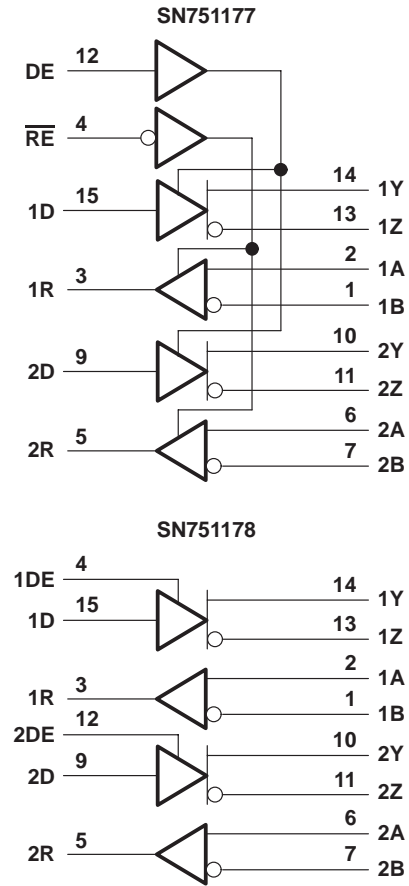

† These symbols are in accordance with ANSI/IEEE Std 91-1984 and IEC Publication 617-12.

## schematics of inputs

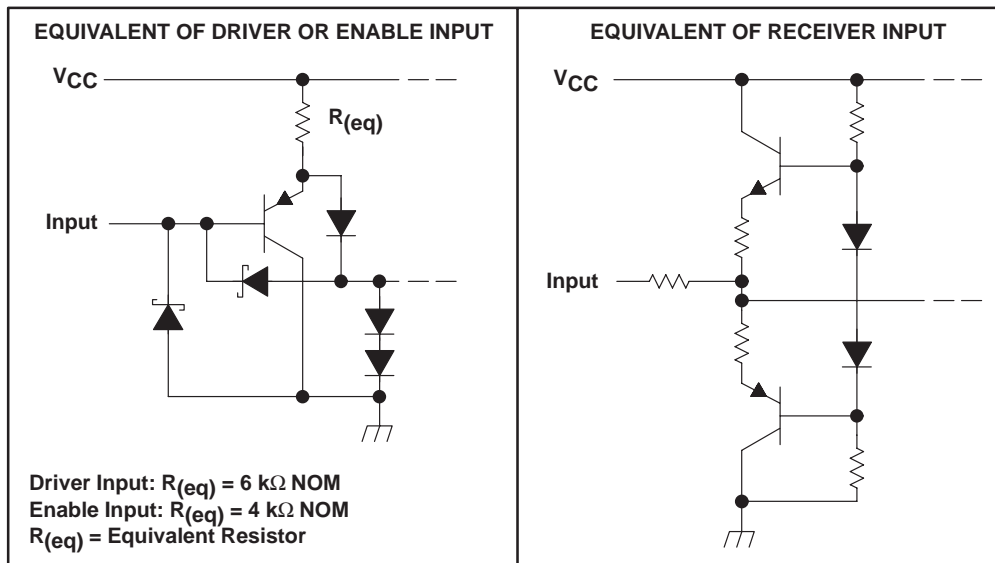

All resistor values are nominal.

# SN751177, SN751178 DUAL DIFFERENTIAL DRIVERS AND RECEIVERS

SLLS059D – FEBRUARY 1990 – REVISED MAY 1999

## schematics of outputs

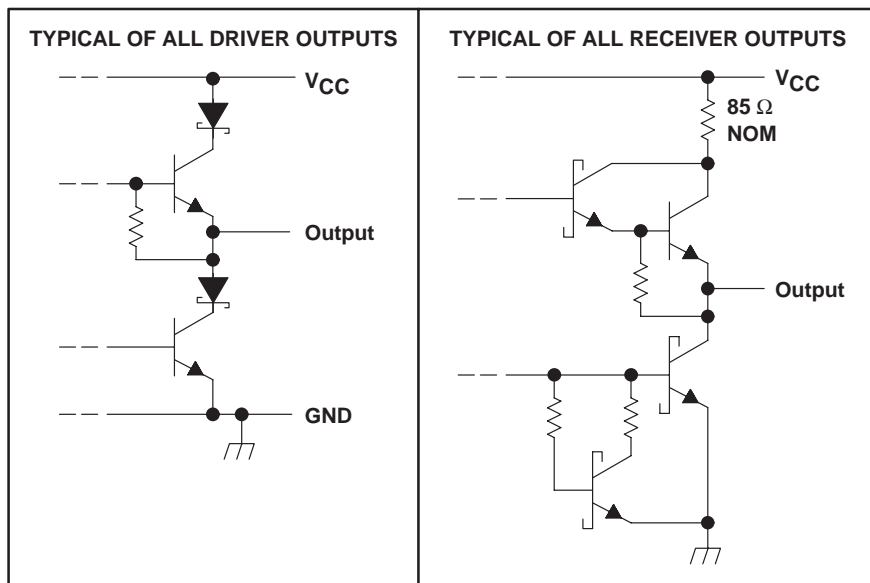

All resistor values are nominal.

## absolute maximum ratings over operating free-air temperature range (unless otherwise noted)†

Supply voltage, $V_{CC}$ (see Note 1)	7 V
Input voltage, $V_I$ (DE, $\overline{RE}$ , and D inputs)	7 V
Receiver input voltage range, $V_I$ (A or B inputs)	-25 V to 25 V
Receiver differential input voltage range, $V_{ID}$ (see Note 2)	-25 V to 25 V
Driver output voltage range, $V_O$	-10 V to 15 V
Receiver low-level output current, $I_{OL}$	50 mA
Package thermal impedance, $\theta_{JA}$ (see Note 3): N package	78°C/W
NS package	111°C/W
Storage temperature range, $T_{stg}$	-65°C to 150°C
Lead temperature 1,6 mm (1/16 inch) from case for 10 seconds	260°C

† Stresses beyond those listed under "absolute maximum ratings" may cause permanent damage to the device. These are stress ratings only, and functional operation of the device at these or any other conditions beyond those indicated under "recommended operating conditions" is not implied. Exposure to absolute-maximum-rated conditions for extended periods may affect device reliability.

- NOTES:
1. All voltage values, except differential input voltage, are with respect to the network ground terminal.
  2. Differential input voltage is measured at the noninverting terminal with respect to the inverting terminal.
  3. The package thermal impedance is calculated in accordance with JESD 51, except for through-hole packages, which use a trace length of zero.

# SN751177, SN751178 DUAL DIFFERENTIAL DRIVERS AND RECEIVERS

SLLS059D – FEBRUARY 1990 – REVISED MAY 1999

## recommended operating conditions

		MIN	NOM	MAX	UNIT
Supply voltage, $V_{CC}$		4.75	5	5.25	V
High-level input voltage, $V_{IH}$	DE, $\overline{RE}$ , and D inputs	2			V
Low-level input voltage, $V_{IL}$		0.8			V
Common-mode output voltage, $V_{OC}$	Driver	$-7^\dagger$		12	V
High-level output current, $I_{OH}$				-60	mA
Low-level output current, $I_{OL}$				60	mA
Common-mode input voltage, $V_{IC}$	Receiver			$\pm 12$	V
Differential input voltage, $V_{ID}$				$\pm 12$	V
High-level output current, $I_{OH}$				-400	$\mu A$
Low-level output current, $I_{OL}$				16	mA
Operating free-air temperature, $T_A$		-20		85	$^\circ C$

<sup>†</sup> The algebraic convention, where the less positive (more negative) limit is designated as minimum, is used in this data sheet for common-mode output and threshold voltage levels only.

# SN751177, SN751178 DUAL DIFFERENTIAL DRIVERS AND RECEIVERS

SLLS059D – FEBRUARY 1990 – REVISED MAY 1999

## DRIVER SECTIONS

electrical characteristics over recommended ranges of supply voltage and operating free-air temperature (unless otherwise noted)

PARAMETER		TEST CONDITIONS	MIN	TYP†	MAX	UNIT
V <sub>IK</sub>	Input clamp voltage	I <sub>I</sub> = -18 mA			-1.5	V
V <sub>OH</sub>	High-level output voltage	V <sub>IH</sub> = 2 V, V <sub>IL</sub> = 0.8 V, I <sub>OH</sub> = -33 mA		3.7		V
V <sub>OL</sub>	Low-level output voltage	V <sub>IH</sub> = 2 V, V <sub>IL</sub> = 0.8 V, I <sub>OH</sub> = 33 mA		1.1		V
V <sub>OD1</sub>	Differential output voltage	I <sub>O</sub> = 0	1.5		6	V
V <sub>OD2</sub>	Differential output voltage	R <sub>L</sub> = 100 Ω, See Figure 1	2 or 1/2 V <sub>OD1</sub> ‡			V
		R <sub>L</sub> = 54 Ω, See Figure 1	1.5		5	
V <sub>OD3</sub>	Differential output voltage	See Note 4	1.5		5	V
Δ V <sub>OD</sub>	Change in magnitude of differential output voltage (see Note 5)	R <sub>L</sub> = 54 Ω or 100 Ω, See Figure 1			±0.2	V
V <sub>OC</sub>	Common-mode output voltage		-1§		3	V
Δ V <sub>OC</sub>	Change in magnitude of common-mode output voltage (see Note 5)				±0.2	V
I <sub>O</sub>	Output current with power off	V <sub>CC</sub> = 0, V <sub>O</sub> = -7 V to 12 V			±100	μA
I <sub>OZ</sub>	High-impedance-state output current	V <sub>O</sub> = -7 V to 12 V			±100	μA
I <sub>IH</sub>	High-level input current	V <sub>IH</sub> = 2.7 V			20	μA
I <sub>IL</sub>	Low-level input current	V <sub>IL</sub> = 0.4 V			-100	μA
I <sub>OS</sub>	Short-circuit output current (see Note 6)	V <sub>O</sub> = -7 V			-250	mA
		V <sub>O</sub> = V <sub>CC</sub>			250	
		V <sub>O</sub> = 12 V			250	
I <sub>CC</sub>	Supply current	No load	Outputs enabled	80	110	mA
			Outputs disabled	50	80	

† All typical values are at V<sub>CC</sub> = 5 V and T<sub>A</sub> = 25°C.

‡ The minimum V<sub>OD2</sub> with a 100-Ω load is either 1/2 V<sub>OD1</sub> or 2 V, whichever is greater.

§ The algebraic convention, where the less positive (more negative) limit is designated as minimum, is used in this data sheet for common-mode output and threshold voltage levels only.

NOTES: 4. See TIA/EIA-485-A Figure 3.5, Test Termination Measurement 2

5. Δ|V<sub>OD</sub>| and Δ|V<sub>OC</sub>| are the changes in magnitude of V<sub>OD</sub> and V<sub>OC</sub>, respectively, that occur when the input is changed from a high level to a low level.

6. Not more than one output should be shorted at a time, and the duration of the short circuit should not exceed one second.

## switching characteristics at V<sub>CC</sub> = 5 V, C<sub>L</sub> = 50 pF, T<sub>A</sub> = 25°C

PARAMETER		TEST CONDITIONS	MIN	TYP	MAX	UNIT
t <sub>d</sub> (OD)	Differential output delay time	R <sub>L</sub> = 54 Ω, See Figure 3		20	25	ns
t <sub>t</sub> (OD)	Differential output transition time			27	35	
t <sub>PLH</sub>	Propagation delay time, low- to high-level output	R <sub>L</sub> = 27 Ω, See Figure 4		20	25	ns
t <sub>PHL</sub>	Propagation delay time, high- to low-level output			20	25	
t <sub>PZH</sub>	Output enable time to high level	R <sub>L</sub> = 110 Ω, See Figure 5		80	120	ns
t <sub>PZL</sub>	Output enable time to low level	R <sub>L</sub> = 110 Ω, See Figure 6		40	60	ns
t <sub>PHZ</sub>	Output disable time from high level	R <sub>L</sub> = 110 Ω, See Figure 5		90	120	ns
t <sub>PLZ</sub>	Output disable time from low level	R <sub>L</sub> = 110 Ω, See Figure 6		30	45	ns



# SN751177, SN751178 DUAL DIFFERENTIAL DRIVERS AND RECEIVERS

SLLS059D – FEBRUARY 1990 – REVISED MAY 1999

## SYMBOL EQUIVALENTS

DATA-SHEET PARAMETER	TIA/EIA-422-B	TIA/EIA-485-A
V <sub>OD1</sub>	V <sub>O</sub>	V <sub>O</sub>
V <sub>OD2</sub>	V <sub>t</sub> (R <sub>L</sub> = 100 Ω)	V <sub>t</sub> (R <sub>L</sub> = 54 Ω)
V <sub>OD3</sub>		V <sub>t</sub> (Test Termination Measurement 2)
Δ V <sub>OD</sub>	V <sub>t</sub>   -  V̄ <sub>t</sub>	V <sub>t</sub>   -  V̄ <sub>t</sub>
V <sub>OC</sub>	V <sub>OS</sub>	V <sub>OS</sub>
Δ V <sub>OC</sub>	V <sub>OS</sub> - V̄ <sub>OS</sub>	V <sub>OS</sub> - V̄ <sub>OS</sub>
I <sub>OS</sub>	I <sub>sa</sub>  ,  I <sub>sb</sub>	
I <sub>O</sub>	I <sub>xa</sub>  ,  I <sub>xb</sub>	I <sub>ia</sub> , I <sub>ib</sub>

## RECEIVER SECTIONS

**electrical characteristics over recommended ranges of common-mode input voltage, supply voltage, and operating free-air temperature (unless otherwise noted)**

PARAMETER		TEST CONDITIONS	MIN	TYP†	MAX	UNIT
V <sub>IT+</sub>	Positive-going input threshold voltage	V <sub>O</sub> = 2.7 V, I <sub>O</sub> = -0.4 mA			0.2	V
V <sub>IT-</sub>	Negative-going input threshold voltage	V <sub>O</sub> = 0.5 V, I <sub>O</sub> = 16 mA	-0.2‡			V
V <sub>hys</sub>	Input hysteresis voltage (V <sub>IT+</sub> - V <sub>IT-</sub> )			50		mV
V <sub>IK</sub>	Enable clamp voltage	SN751177 I <sub>I</sub> = -18 mA			-1.5	V
V <sub>OH</sub>	High-level output voltage	V <sub>ID</sub> = 200 mV, I <sub>OH</sub> = -400 μA		2.7		V
V <sub>OL</sub>	Low-level output voltage	V <sub>ID</sub> = -200 mV			0.45	V
					0.5	
I <sub>OZ</sub>	High-impedance-state output current	SN751177 V <sub>O</sub> = 0.4 V to 2.4 V			±20	μA
I <sub>I</sub>	Line input current (see Note 7)	Other input at 0 V		V <sub>I</sub> = 12 V	1	mA
				V <sub>I</sub> = -7 V	-0.8	
I <sub>IH</sub>	High-level enable input current	SN751177 V <sub>IH</sub> = 2.7 V			20	μA
I <sub>IL</sub>	Low-level enable input current	SN751177 V <sub>IL</sub> = 0.4 V			-100	μA
I <sub>OS</sub>	Short-circuit output current (see Note 6)		-15		-85	μA
I <sub>CC</sub>	Supply current	No load, Outputs enabled		80	110	mA
r <sub>i</sub>	Input resistance			12		kΩ

† All typical values are at V<sub>CC</sub> = 5 V and T<sub>A</sub> = 25°C.

‡ The algebraic convention, where the less positive (more negative) limit is designated as minimum, is used in this data sheet for common-mode output and threshold voltage levels only.

NOTES: 6. Not more than one output should be shorted at a time, and the duration of the short circuit should not exceed one second.

7. Refer to ANSI Standards TIA/EIA-422-B, TIA/EIA-423-A, and TIA/EIA-485-A for exact conditions.



# SN751177, SN751178 DUAL DIFFERENTIAL DRIVERS AND RECEIVERS

SLLS059D – FEBRUARY 1990 – REVISED MAY 1999

switching characteristics at  $V_{CC} = 5\text{ V}$ ,  $C_L = 15\text{ pF}$ ,  $T_A = 25^\circ\text{C}$

PARAMETER	TEST CONDITIONS	MIN	TYP	MAX	UNIT
$t_{PLH}$ Propagation delay time, low- to high-level output	$V_{ID} = -1.5\text{ V to } 1.5\text{ V}$ , See Figure 7		20	35	ns
$t_{PHL}$ Propagation delay time, high- to low-level output			22	35	ns
$t_{PZH}$ Output enable time to high level	SN751177 See Figure 8		17	25	ns
$t_{PZL}$ Output enable time to low level			20	27	ns
$t_{PHZ}$ Output disable time from high level			25	40	ns
$t_{PLZ}$ Output disable time from low level			30	40	ns

## PARAMETER MEASUREMENT INFORMATION

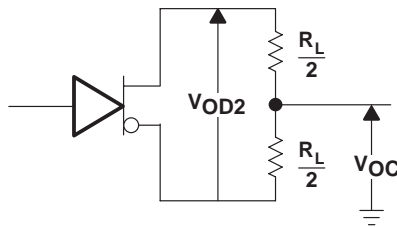

Figure 1. Driver Test Circuit,  $V_{OD}$  and  $V_{OC}$

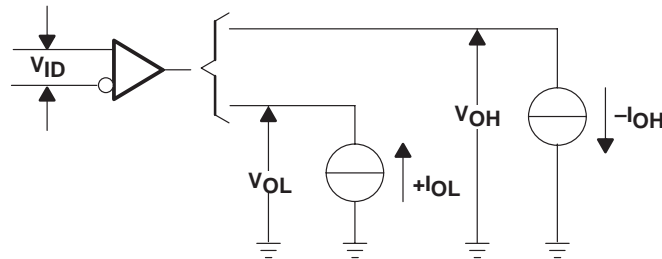
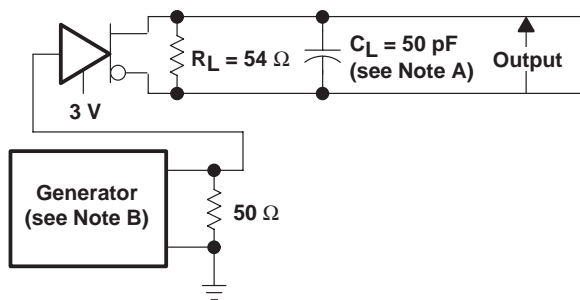
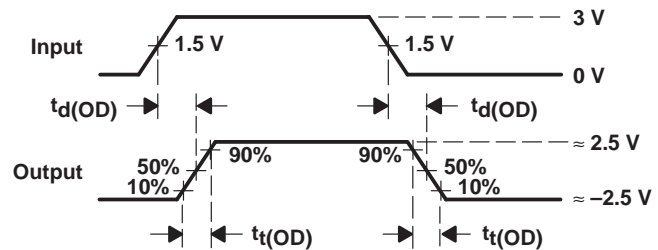

Figure 2. Receiver Test Circuit,  $V_{OH}$  and  $V_{OL}$



TEST CIRCUIT



VOLTAGE WAVEFORMS

NOTES: A.  $C_L$  includes probe and jig capacitance.

B. The pulse generator has the following characteristics:  $PRR \leq 1\text{ MHz}$ , 50% duty cycle,  $Z_O = 50\ \Omega$ ,  $t_r \leq 6\text{ ns}$ ,  $t_f \leq 6\text{ ns}$ .

Figure 3. Driver Differential Output-Delay and Transition-Time Test Circuit and Voltage Waveforms

PARAMETER MEASUREMENT INFORMATION

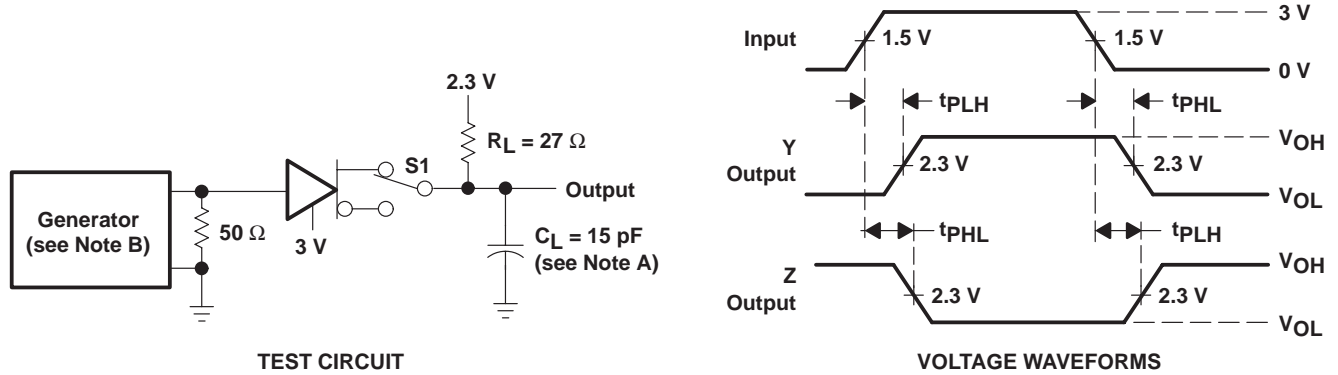

NOTES: A.  $C_L$  includes probe and jig capacitance.  
B. The pulse generator has the following characteristics:  $PRR \leq 1$  MHz, 50% duty cycle,  $Z_O = 50 \Omega$ ,  $t_r \leq 6$  ns,  $t_f \leq 6$  ns.

Figure 4. Driver Propagation-Time Test Circuit and Voltage Waveforms

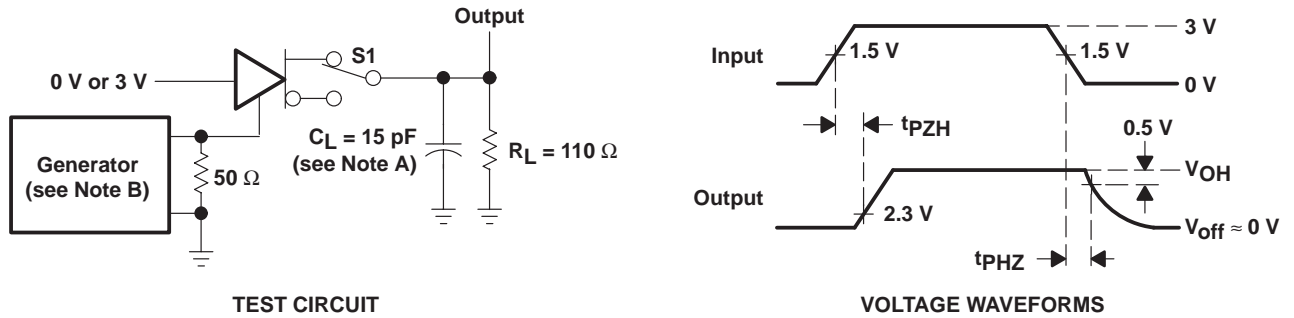

NOTES: A.  $C_L$  includes probe and jig capacitance.  
B. The pulse generator has the following characteristics:  $PRR \leq 1$  MHz, 50% duty cycle,  $Z_O = 50 \Omega$ ,  $t_r \leq 6$  ns,  $t_f \leq 6$  ns.

Figure 5. Driver Enable- and Disable-Time Test Circuit and Voltage Waveforms

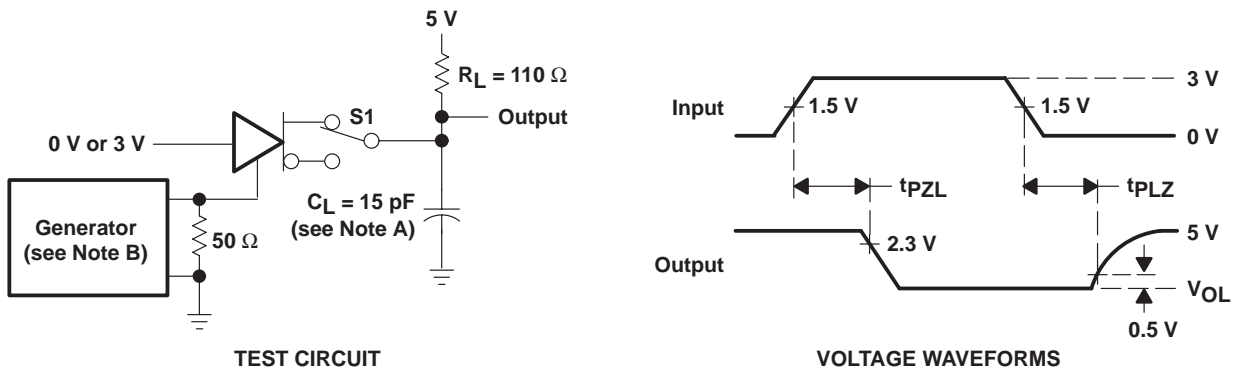

NOTES: A.  $C_L$  includes probe and jig capacitance.  
B. The pulse generator has the following characteristics:  $PRR \leq 1$  MHz, 50% duty cycle,  $Z_O = 50 \Omega$ ,  $t_r \leq 6$  ns,  $t_f \leq 6$  ns.

Figure 6. Driver Enable- and Disable-Time Test Circuit and Voltage Waveforms

# SN751177, SN751178 DUAL DIFFERENTIAL DRIVERS AND RECEIVERS

SLLS059D – FEBRUARY 1990 – REVISED MAY 1999

## PARAMETER MEASUREMENT INFORMATION

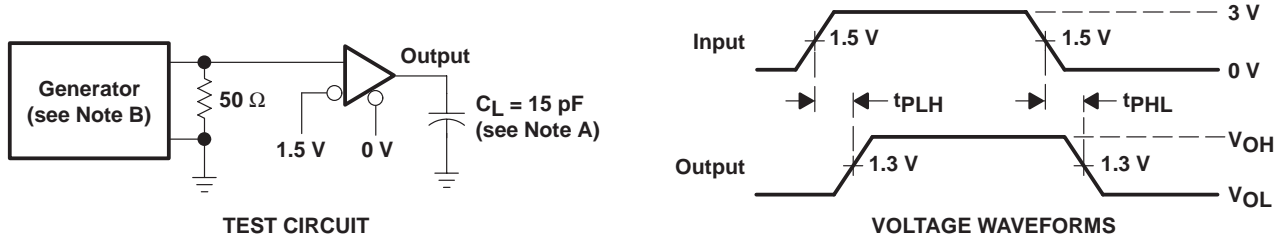

NOTES: A.  $C_L$  includes probe and jig capacitance.  
B. The pulse generator has the following characteristics:  $PRR \leq 1 \text{ MHz}$ , 50% duty cycle,  $Z_O = 50 \Omega$ ,  $t_r \leq 6 \text{ ns}$ ,  $t_f \leq 6 \text{ ns}$ .

Figure 7. Receiver Propagation-Time Test Circuit and Voltage Waveforms

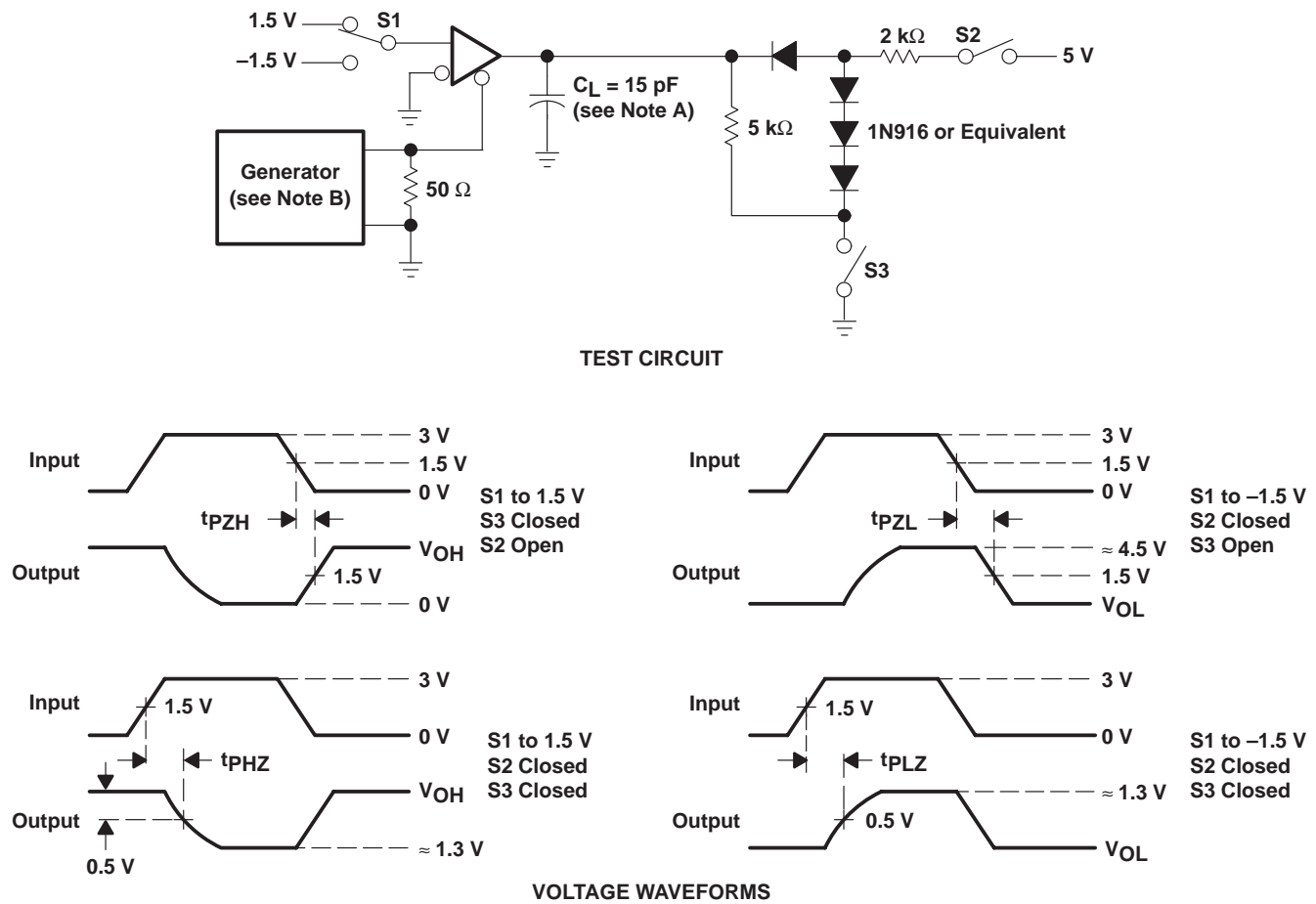

NOTES: A.  $C_L$  includes probe and jig capacitance.  
B. The pulse generator has the following characteristics:  $PRR \leq 1 \text{ MHz}$ , 50% duty cycle,  $Z_O = 50 \Omega$ ,  $t_r \leq 6 \text{ ns}$ ,  $t_f \leq 6 \text{ ns}$ .

Figure 8. Receiver Output Enable- and Disable-Time Test Circuit and Voltage Waveforms

**PACKAGING INFORMATION**

Orderable Device	Status <sup>(1)</sup>	Package Type	Package Drawing	Pins	Package Qty	Eco Plan <sup>(2)</sup>	Lead/Ball Finish	MSL Peak Temp <sup>(3)</sup>
SN751177N	ACTIVE	PDIP	N	16	25	Pb-Free (RoHS)	CU NIPDAU	N / A for Pkg Type
SN751177NE4	ACTIVE	PDIP	N	16	25	Pb-Free (RoHS)	CU NIPDAU	N / A for Pkg Type
SN751177NSR	ACTIVE	SO	NS	16	2000	Green (RoHS & no Sb/Br)	CU NIPDAU	Level-1-260C-UNLIM
SN751177NSRE4	ACTIVE	SO	NS	16	2000	Green (RoHS & no Sb/Br)	CU NIPDAU	Level-1-260C-UNLIM
SN751177NSRG4	ACTIVE	SO	NS	16	2000	Green (RoHS & no Sb/Br)	CU NIPDAU	Level-1-260C-UNLIM
SN751178N	ACTIVE	PDIP	N	16	25	Pb-Free (RoHS)	CU NIPDAU	N / A for Pkg Type
SN751178NE4	ACTIVE	PDIP	N	16	25	Pb-Free (RoHS)	CU NIPDAU	N / A for Pkg Type
SN751178NSR	ACTIVE	SO	NS	16	2000	Green (RoHS & no Sb/Br)	CU NIPDAU	Level-1-260C-UNLIM
SN751178NSRE4	ACTIVE	SO	NS	16	2000	Green (RoHS & no Sb/Br)	CU NIPDAU	Level-1-260C-UNLIM
SN751178NSRG4	ACTIVE	SO	NS	16	2000	Green (RoHS & no Sb/Br)	CU NIPDAU	Level-1-260C-UNLIM

<sup>(1)</sup> The marketing status values are defined as follows:

**ACTIVE:** Product device recommended for new designs.

**LIFEBUY:** TI has announced that the device will be discontinued, and a lifetime-buy period is in effect.

**NRND:** Not recommended for new designs. Device is in production to support existing customers, but TI does not recommend using this part in a new design.

**PREVIEW:** Device has been announced but is not in production. Samples may or may not be available.

**OBsolete:** TI has discontinued the production of the device.

<sup>(2)</sup> Eco Plan - The planned eco-friendly classification: Pb-Free (RoHS), Pb-Free (RoHS Exempt), or Green (RoHS & no Sb/Br) - please check <http://www.ti.com/productcontent> for the latest availability information and additional product content details.

**TBD:** The Pb-Free/Green conversion plan has not been defined.

**Pb-Free (RoHS):** TI's terms "Lead-Free" or "Pb-Free" mean semiconductor products that are compatible with the current RoHS requirements for all 6 substances, including the requirement that lead not exceed 0.1% by weight in homogeneous materials. Where designed to be soldered at high temperatures, TI Pb-Free products are suitable for use in specified lead-free processes.

**Pb-Free (RoHS Exempt):** This component has a RoHS exemption for either 1) lead-based flip-chip solder bumps used between the die and package, or 2) lead-based die adhesive used between the die and leadframe. The component is otherwise considered Pb-Free (RoHS compatible) as defined above.

**Green (RoHS & no Sb/Br):** TI defines "Green" to mean Pb-Free (RoHS compatible), and free of Bromine (Br) and Antimony (Sb) based flame retardants (Br or Sb do not exceed 0.1% by weight in homogeneous material)

<sup>(3)</sup> MSL, Peak Temp. -- The Moisture Sensitivity Level rating according to the JEDEC industry standard classifications, and peak solder temperature.

**Important Information and Disclaimer:** The information provided on this page represents TI's knowledge and belief as of the date that it is provided. TI bases its knowledge and belief on information provided by third parties, and makes no representation or warranty as to the accuracy of such information. Efforts are underway to better integrate information from third parties. TI has taken and continues to take reasonable steps to provide representative and accurate information but may not have conducted destructive testing or chemical analysis on incoming materials and chemicals. TI and TI suppliers consider certain information to be proprietary, and thus CAS numbers and other limited information may not be available for release.

In no event shall TI's liability arising out of such information exceed the total purchase price of the TI part(s) at issue in this document sold by TI to Customer on an annual basis.

**TAPE AND REEL INFORMATION**

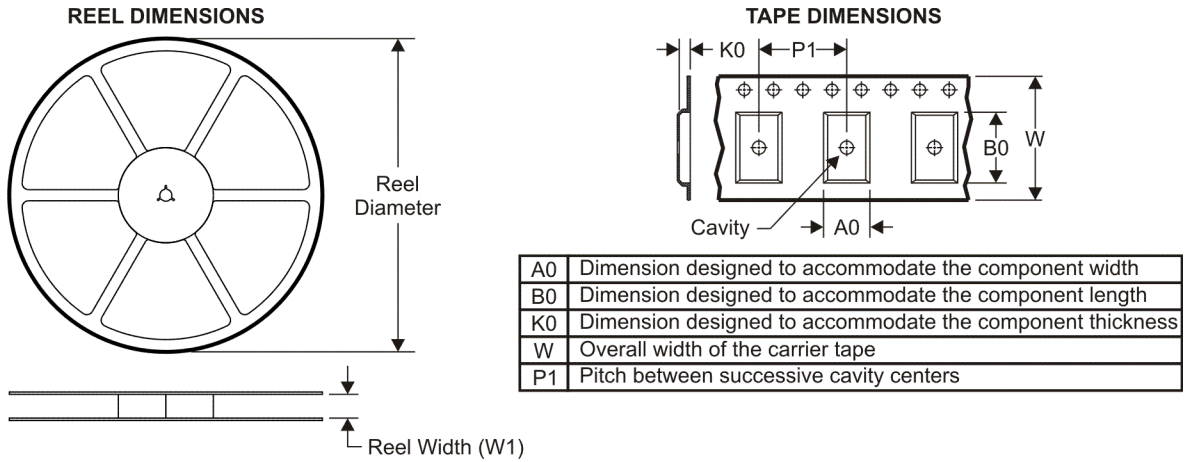

**QUADRANT ASSIGNMENTS FOR PIN 1 ORIENTATION IN TAPE**

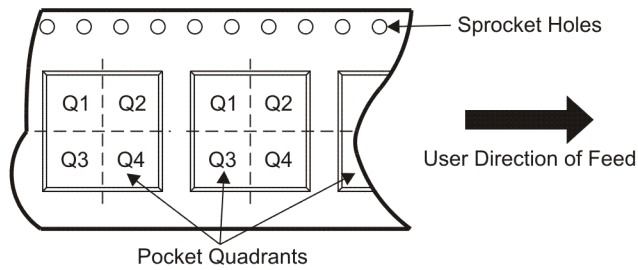

\*All dimensions are nominal

Device	Package Type	Package Drawing	Pins	SPQ	Reel Diameter (mm)	Reel Width W1 (mm)	A0 (mm)	B0 (mm)	K0 (mm)	P1 (mm)	W (mm)	Pin1 Quadrant
SN751177NSR	SO	NS	16	2000	330.0	16.4	8.2	10.5	2.5	12.0	16.0	Q1
SN751178NSR	SO	NS	16	2000	330.0	16.4	8.2	10.5	2.5	12.0	16.0	Q1

**TAPE AND REEL BOX DIMENSIONS**



\*All dimensions are nominal

Device	Package Type	Package Drawing	Pins	SPQ	Length (mm)	Width (mm)	Height (mm)
SN751177NSR	SO	NS	16	2000	346.0	346.0	33.0
SN751178NSR	SO	NS	16	2000	346.0	346.0	33.0

# MECHANICAL DATA

NS (R-PDSO-G\*\*)

PLASTIC SMALL-OUTLINE PACKAGE

14-PINS SHOWN

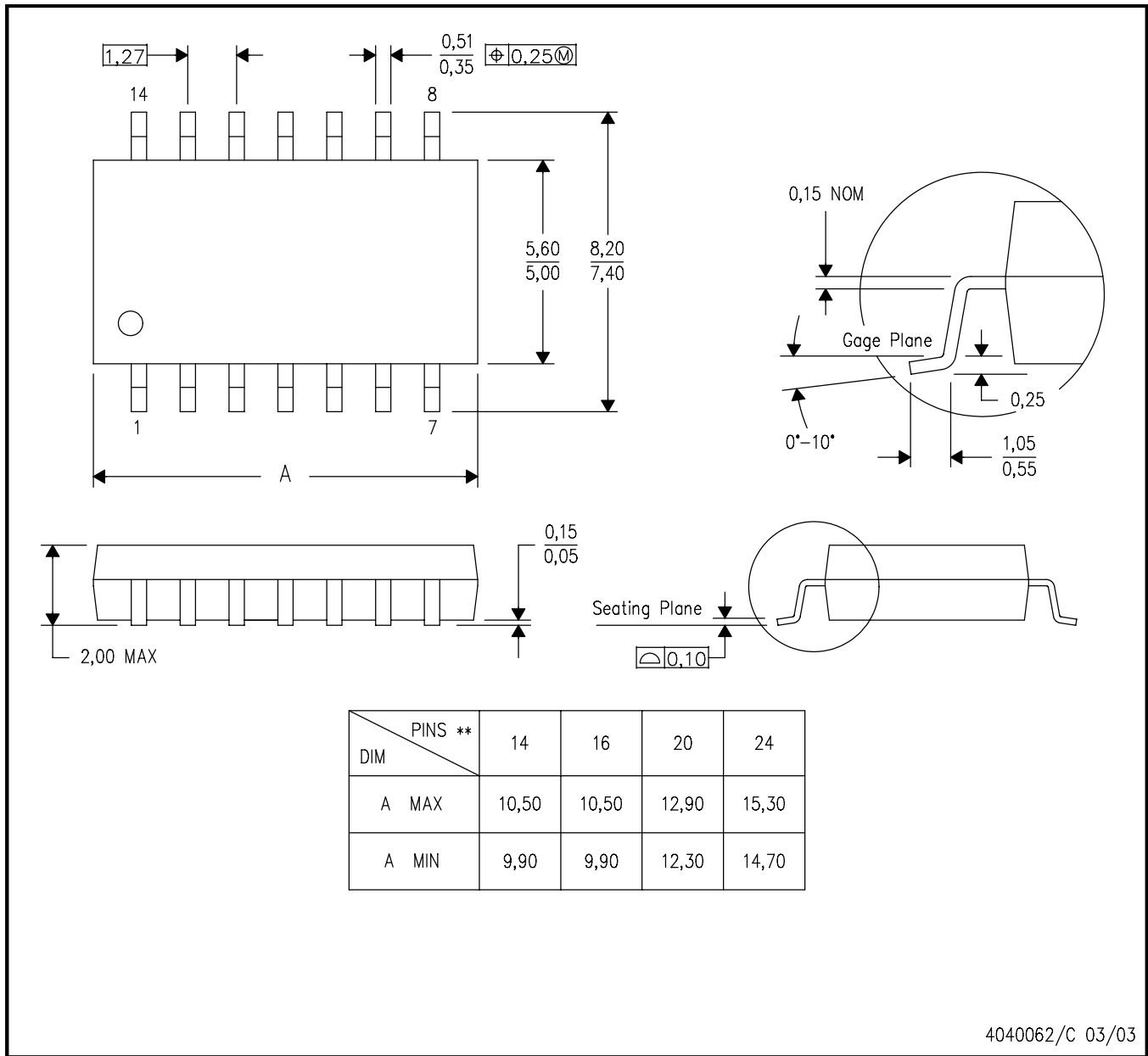

- NOTES:
- A. All linear dimensions are in millimeters.
  - B. This drawing is subject to change without notice.
  - C. Body dimensions do not include mold flash or protrusion, not to exceed 0,15.

N (R-PDIP-T\*\*)

PLASTIC DUAL-IN-LINE PACKAGE

16 PINS SHOWN



- NOTES:
- A. All linear dimensions are in inches (millimeters).
  - B. This drawing is subject to change without notice.
  - C Falls within JEDEC MS-001, except 18 and 20 pin minimum body length (Dim A).
  - D The 20 pin end lead shoulder width is a vendor option, either half or full width.

4040049/E 12/2002

## IMPORTANT NOTICE

Texas Instruments Incorporated and its subsidiaries (TI) reserve the right to make corrections, modifications, enhancements, improvements, and other changes to its products and services at any time and to discontinue any product or service without notice. Customers should obtain the latest relevant information before placing orders and should verify that such information is current and complete. All products are sold subject to TI's terms and conditions of sale supplied at the time of order acknowledgment.

TI warrants performance of its hardware products to the specifications applicable at the time of sale in accordance with TI's standard warranty. Testing and other quality control techniques are used to the extent TI deems necessary to support this warranty. Except where mandated by government requirements, testing of all parameters of each product is not necessarily performed.

TI assumes no liability for applications assistance or customer product design. Customers are responsible for their products and applications using TI components. To minimize the risks associated with customer products and applications, customers should provide adequate design and operating safeguards.

TI does not warrant or represent that any license, either express or implied, is granted under any TI patent right, copyright, mask work right, or other TI intellectual property right relating to any combination, machine, or process in which TI products or services are used. Information published by TI regarding third-party products or services does not constitute a license from TI to use such products or services or a warranty or endorsement thereof. Use of such information may require a license from a third party under the patents or other intellectual property of the third party, or a license from TI under the patents or other intellectual property of TI.

Reproduction of TI information in TI data books or data sheets is permissible only if reproduction is without alteration and is accompanied by all associated warranties, conditions, limitations, and notices. Reproduction of this information with alteration is an unfair and deceptive business practice. TI is not responsible or liable for such altered documentation. Information of third parties may be subject to additional restrictions.

Resale of TI products or services with statements different from or beyond the parameters stated by TI for that product or service voids all express and any implied warranties for the associated TI product or service and is an unfair and deceptive business practice. TI is not responsible or liable for any such statements.

TI products are not authorized for use in safety-critical applications (such as life support) where a failure of the TI product would reasonably be expected to cause severe personal injury or death, unless officers of the parties have executed an agreement specifically governing such use. Buyers represent that they have all necessary expertise in the safety and regulatory ramifications of their applications, and acknowledge and agree that they are solely responsible for all legal, regulatory and safety-related requirements concerning their products and any use of TI products in such safety-critical applications, notwithstanding any applications-related information or support that may be provided by TI. Further, Buyers must fully indemnify TI and its representatives against any damages arising out of the use of TI products in such safety-critical applications.

TI products are neither designed nor intended for use in military/aerospace applications or environments unless the TI products are specifically designated by TI as military-grade or "enhanced plastic." Only products designated by TI as military-grade meet military specifications. Buyers acknowledge and agree that any such use of TI products which TI has not designated as military-grade is solely at the Buyer's risk, and that they are solely responsible for compliance with all legal and regulatory requirements in connection with such use.

TI products are neither designed nor intended for use in automotive applications or environments unless the specific TI products are designated by TI as compliant with ISO/TS 16949 requirements. Buyers acknowledge and agree that, if they use any non-designated products in automotive applications, TI will not be responsible for any failure to meet such requirements.

Following are URLs where you can obtain information on other Texas Instruments products and application solutions:

### Products

Amplifiers	<a href="http://amplifier.ti.com">amplifier.ti.com</a>
Data Converters	<a href="http://dataconverter.ti.com">dataconverter.ti.com</a>
DSP	<a href="http://dsp.ti.com">dsp.ti.com</a>
Clocks and Timers	<a href="http://www.ti.com/clocks">www.ti.com/clocks</a>
Interface	<a href="http://interface.ti.com">interface.ti.com</a>
Logic	<a href="http://logic.ti.com">logic.ti.com</a>
Power Mgmt	<a href="http://power.ti.com">power.ti.com</a>
Microcontrollers	<a href="http://microcontroller.ti.com">microcontroller.ti.com</a>
RFID	<a href="http://www.ti-rfid.com">www.ti-rfid.com</a>
RF/IF and ZigBee® Solutions	<a href="http://www.ti.com/lprf">www.ti.com/lprf</a>

### Applications

Audio	<a href="http://www.ti.com/audio">www.ti.com/audio</a>
Automotive	<a href="http://www.ti.com/automotive">www.ti.com/automotive</a>
Broadband	<a href="http://www.ti.com/broadband">www.ti.com/broadband</a>
Digital Control	<a href="http://www.ti.com/digitalcontrol">www.ti.com/digitalcontrol</a>
Medical	<a href="http://www.ti.com/medical">www.ti.com/medical</a>
Military	<a href="http://www.ti.com/military">www.ti.com/military</a>
Optical Networking	<a href="http://www.ti.com/opticalnetwork">www.ti.com/opticalnetwork</a>
Security	<a href="http://www.ti.com/security">www.ti.com/security</a>
Telephony	<a href="http://www.ti.com/telephony">www.ti.com/telephony</a>
Video & Imaging	<a href="http://www.ti.com/video">www.ti.com/video</a>
Wireless	<a href="http://www.ti.com/wireless">www.ti.com/wireless</a>

Mailing Address: Texas Instruments, Post Office Box 655303, Dallas, Texas 75265  
Copyright © 2008, Texas Instruments Incorporated

## Looking for pricing, stock, or lifecycle information?

Click below to explore more details on WIN SOURCE:

 [View SN751177N on WIN SOURCE](#)

 [Texas Instruments](#) Information

## Optimize Your Supply Chain with WIN SOURCE Solutions

-  Global Sourcing Solution
-  Obsolete Management
-  Cost Control Management
-  Shortage Management
-  Alternative Solution
-  Excess Inventory Management