



**THE DATASHEET OF
SN75155DR**



SN75155 LINE DRIVER AND RECEIVER

SLLS017C – JULY 1986 – REVISED MAY 1995

- Meets or Exceeds the Requirements of ANSI EIA/TIA-232-E and ITU Recommendation V.28
- 10-mA Current Limited Output
- Wide Range of Supply Voltage
 $V_{CC} = 4.5 \text{ V to } 15 \text{ V}$
- Low Power . . . 130 mW
- Built-In 5-V Regulator
- Response Control Provides:
Input Threshold Shifting
Input Noise Filtering
- Power-Off Output Resistance . . . 300 Ω Typ
- Driver Input TTL Compatible

D OR P PACKAGE
TOP VIEW

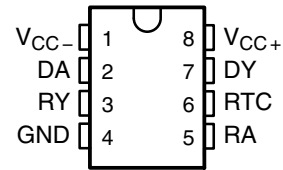

description

The SN75155 monolithic line driver and receiver is designed to satisfy the requirements of the standard interface between data terminal equipment and data communication equipment as defined by ANSI EIA/TIA-232-E. A response control input is provided for the receiver. A resistor or a resistor and a bias voltage can be connected between the response control input and ground to provide noise filtering. The driver used is similar to the SN75188. The receiver used is similar to the SN75189A.

The SN75155 is characterized for operation from 0°C to 70°C.

logic symbol†

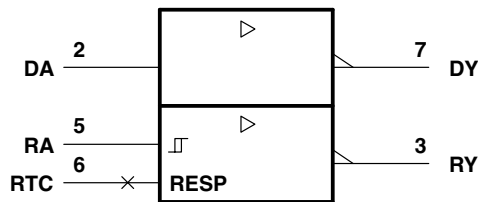

† This symbol is in accordance with ANSI/IEEE Std 91-1984 and IEC Publication 617-12

logic diagram

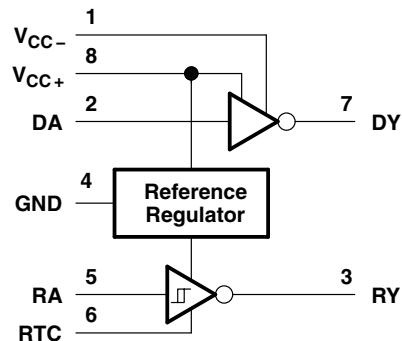

Please be aware that an important notice concerning availability, standard warranty, and use in critical applications of Texas Instruments semiconductor products and disclaimers thereto appears at the end of this data sheet.

PRODUCTION DATA information is current as of publication date. Products conform to specifications per the terms of Texas Instruments standard warranty. Production processing does not necessarily include testing of all parameters.

 **TEXAS
INSTRUMENTS**

POST OFFICE BOX 655303 • DALLAS, TEXAS 75265

Copyright © 1995, Texas Instruments Incorporated

SN75155 LINE DRIVER AND RECEIVER

SLLS017C – JULY 1986 – REVISED MAY 1995

schematic

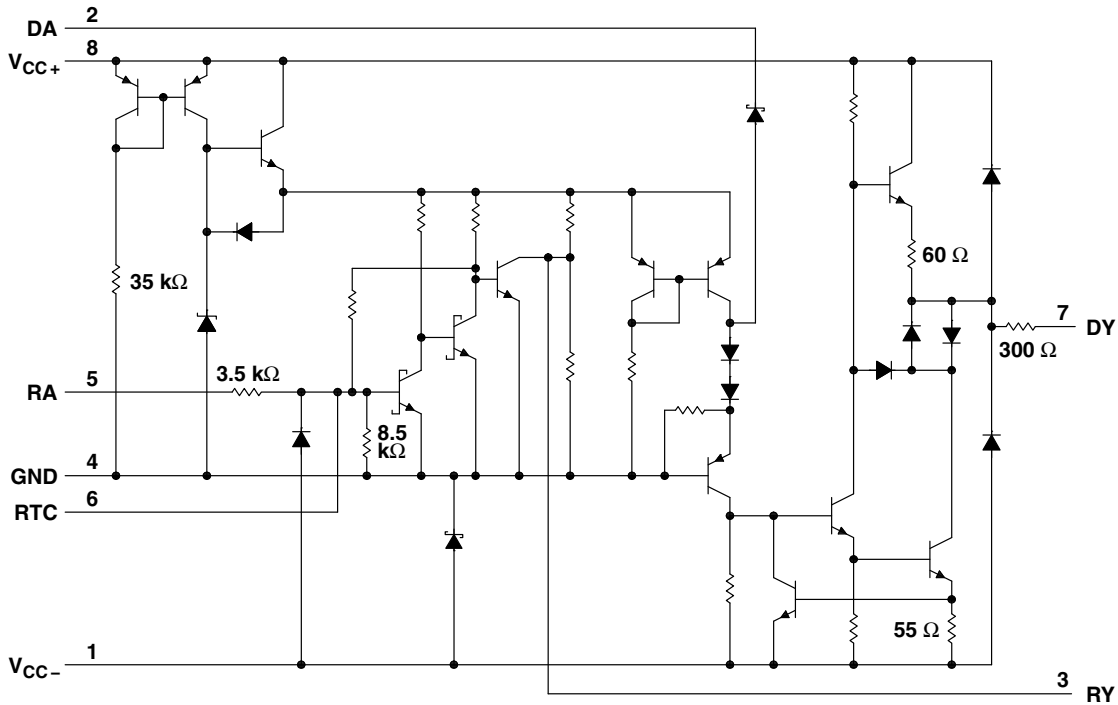

absolute maximum ratings over operating free-air temperature range (unless otherwise noted)†

Supply voltage, V_{CC+} (see Note 1)	15 V
Supply voltage, V_{CC-} (see Note 1)	-15 V
Input voltage range, V_i : Driver	-15 V to 15 V
Receiver	-30 V to 30 V
Output voltage range (driver), V_o	-15 V to 15 V
Continuous total power dissipation	See Dissipation Rating Table
Operating free-air temperature range, T_A	0°C to 70°C
Storage temperature range, T_{stg}	-65°C to 150°C
Lead temperature 1,6 mm (1/16 inch) from case for 10 seconds	260°C

† Stresses beyond those listed under "absolute maximum ratings" may cause permanent damage to the device. These are stress ratings only, and functional operation of the device at these or any other conditions beyond those indicated under "recommended operating conditions" is not implied. Exposure to absolute-maximum-rated conditions for extended periods may affect device reliability.

NOTE 1: All voltage values are with respect to network ground terminal.

DISSIPATION RATING TABLE

PACKAGE	$T_A \leq 25^\circ\text{C}$	DERATING FACTOR	$T_A = 70^\circ\text{C}$
	POWER RATING	ABOVE $T_A = 25^\circ\text{C}$	POWER RATING
D	725 mW	5.8 mW/°C	464 mW
P	1000 mW	8.0 mW/°C	640 mW



POST OFFICE BOX 655303 • DALLAS, TEXAS 75265

SN75155 LINE DRIVER AND RECEIVER

SLLS017C – JULY 1986 – REVISED MAY 1995

recommended operating conditions

	MIN	NOM	MAX	UNIT
Supply voltage, V_{CC+}	4.5	12	15	V
Supply voltage, V_{CC-}	-4.5	-12	-15	V
Output voltage, driver, $V_{O(D)}$			± 15	V
Input voltage, receiver, $V_{I(R)}$	-25		25	V
High-level input voltage, driver, V_{IH}	2			V
Low-level input voltage, driver, V_{IL}			0.8	V
Response control current			± 5.5	mA
Output current, receiver, $I_{O(R)}$			24	mA
Operating free-air temperature, T_A	0		70	$^{\circ}\text{C}$

electrical characteristics over recommended operating free-air temperature range (unless otherwise noted)

total device

PARAMETER		TEST CONDITIONS	MIN	TYP [†]	MAX	UNIT
I_{CCH+}	High-level supply current	$V_{CC+} = 5\text{ V}, V_{CC-} = -5\text{ V}$		6.3	8.1	mA
		$V_{CC+} = 9\text{ V}, V_{CC-} = -9\text{ V}$		9.1	11.9	
		$V_{CC+} = 12\text{ V}, V_{CC-} = -12\text{ V}$		10.4	14	
I_{CCL+}	Low-level supply current	$V_{CC+} = 5\text{ V}, V_{CC-} = -5\text{ V}$		2.5	3.4	mA
		$V_{CC+} = 9\text{ V}, V_{CC-} = -9\text{ V}$		3.7	5.1	
		$V_{CC+} = 12\text{ V}, V_{CC-} = -12\text{ V}$		4.1	5.6	
I_{CC+}	Supply current	$V_{CC+} = 5\text{ V}, V_{CC-} = 0$		4.8	6.4	mA
		$V_{CC+} = 9\text{ V}, V_{CC-} = 0$		6.7	9.1	
I_{CCH-}	High-level supply current	$V_{CC+} = 5\text{ V}, V_{CC-} = -5\text{ V}$		-2.4	-3.1	mA
		$V_{CC+} = 9\text{ V}, V_{CC-} = -9\text{ V}$		-3.9	-4.9	
		$V_{CC+} = 12\text{ V}, V_{CC-} = -12\text{ V}$		-4.8	-6.1	
I_{CCL-}	Low-level supply current	$V_{CC+} = 5\text{ V}, V_{CC-} = -5\text{ V}$		-0.2	-0.35	mA
		$V_{CC+} = 9\text{ V}, V_{CC-} = -9\text{ V}$		-0.25	-0.4	
		$V_{CC+} = 12\text{ V}, V_{CC-} = -12\text{ V}$		-0.27	-0.45	

[†] All typical values are at $T_A = 25^{\circ}\text{C}$.

SN75155

LINE DRIVER AND RECEIVER

SLLS017C – JULY 1986 – REVISED MAY 1995

electrical characteristics over recommended operating free-air temperature range, $V_{CC+} = 12\text{ V}$, $V_{CC-} = -12\text{ V}$ (unless otherwise noted)

driver section

PARAMETER	TEST CONDITIONS	MIN	TYP†	MAX	UNIT
V_{OH} High-level output voltage	$V_{IL} = 0.8\text{ V}$, $R_L = 3\text{ k}\Omega$	$V_{CC+} = 5\text{ V}$, $V_{CC-} = -5\text{ V}$	3.2	3.7	V
		$V_{CC+} = 9\text{ V}$, $V_{CC-} = -9\text{ V}$	6.5	7.2	
		$V_{CC+} = 12\text{ V}$, $V_{CC-} = -12\text{ V}$	8.9	9.8	
V_{OL} Low-level output voltage (see Note 2)	$V_{IH} = 2\text{ V}$, $R_L = 3\text{ k}\Omega$	$V_{CC+} = 5\text{ V}$, $V_{CC-} = -5\text{ V}$	-3.6	-3.2	V
		$V_{CC+} = 9\text{ V}$, $V_{CC-} = -9\text{ V}$	-7.1	-6.4	
		$V_{CC+} = 12\text{ V}$, $V_{CC-} = -12\text{ V}$	-9.7	-8.8	
I_{IH} High-level input current	$V_I = 7\text{ V}$			5	μA
I_{IL} Low-level input current	$V_I = 0$		-0.73	-1.2	mA
$I_{OS(H)}$ High-level short-circuit output current	$V_I = 0.8\text{ V}$, $V_O = 0$	-7	-12	-14.5	mA
$I_{OS(L)}$ Low-level short-circuit output current	$V_I = 2\text{ V}$, $V_O = 0$	6.5	11.5	15	mA
r_o Output resistance with power off	$V_O = -2\text{ V}$ to 2 V		300		Ω

receiver section (see Figure 1)

PARAMETER	TEST CONDITIONS	MIN	TYP†	MAX	UNIT	
V_{IT+} Positive-going input threshold voltage		1.2	1.9	2.3	V	
V_{IT-} Negative-going input threshold voltage		0.6	0.95	1.2	V	
V_{hys} Hysteresis voltage ($V_{IT+} - V_{IT-}$)		0.6			V	
$V_{O(H)}$ High-level output voltage	$V_I = 0.6\text{ V}$, $I_{OH} = 10\text{ }\mu\text{A}$	$V_{CC+} = 5\text{ V}$, $V_{CC-} = -5\text{ V}$	3.7	4.1	4.5	V
		$V_{CC+} = 12\text{ V}$, $V_{CC-} = -12\text{ V}$	4.4	4.7	5.2	
	$V_I = 0.6\text{ V}$, $I_{OH} = 0.4\text{ mA}$	$V_{CC+} = 5\text{ V}$, $V_{CC-} = -5\text{ V}$	3.1	3.4	3.8	
		$V_{CC+} = 12\text{ V}$, $V_{CC-} = -12\text{ V}$	3.6	4	4.5	
$V_{O(L)}$ Low-level output voltage	$V_I = 2.3\text{ V}$, $I_{OL} = 24\text{ mA}$		0.2	0.3	V	
I_{IH} High-level input current	$V_I = 2.5\text{ V}$	3.6	6.7	10	mA	
	$V_I = 3\text{ V}$	0.43	0.67	1	mA	
I_{IL} Low-level input current	$V_I = -25\text{ V}$	-3.6	-6.7	-10	mA	
	$V_I = -3\text{ V}$	-0.43	-0.67	-1	mA	
I_{OS} Short-circuit output current	$V_I = 0.6\text{ V}$		-2.8	-3.7	mA	

† All typical values are at $T_A = 25^\circ\text{C}$.

NOTE 2: The algebraic limit system, in which the more positive (less negative) limit is designated as maximum, is used in this data sheet for logic voltage levels only (e.g., if -8.8 V is the maximum, the typical value is a more negative value).



switching characteristics over recommended operating free-air temperature range, $V_{CC+} = 5\text{ V}$, $V_{CC-} = -5\text{ V}$, $C_L = 50\text{ pF}$ (unless otherwise noted)

driver section (see Figure 2)

PARAMETER	TEST CONDITIONS	MIN	TYP†	MAX	UNIT
t_{PLH} Propagation delay time, low- to high level output	$R_L = 3\text{ k}\Omega$		250	480	ns
t_{PHL} Propagation delay time, high- to low level output			80	150	
t_r Output rise time	$R_L = 3\text{ k}\Omega$		67	180	ns
	$R_L = 3\text{ k}\Omega$ to $7\text{ k}\Omega$, $C_L = 2500\text{ pF}$		2.4	3	μs
t_f Output fall time	$R_L = 3\text{ k}\Omega$		48	160	ns
	$R_L = 3\text{ k}\Omega$ to $7\text{ k}\Omega$, $C_L = 2500\text{ pF}$		1.9	3	μs

receiver section (see Figure 3)

PARAMETER	TEST CONDITIONS	MIN	TYP†	MAX	UNIT
t_{PLH} Propagation delay time, low- to high level output	$R_L = 400\ \Omega$		175	245	ns
t_{PHL} Propagation delay time, high- to low level output			37	100	
t_r Output rise time	$R_L = 400\ \Omega$		255	360	ns
t_f Output fall time	$R_L = 400\ \Omega$		23	50	ns

† All typical values are at $T_A = 25^\circ\text{C}$.

PARAMETER MEASUREMENT INFORMATION

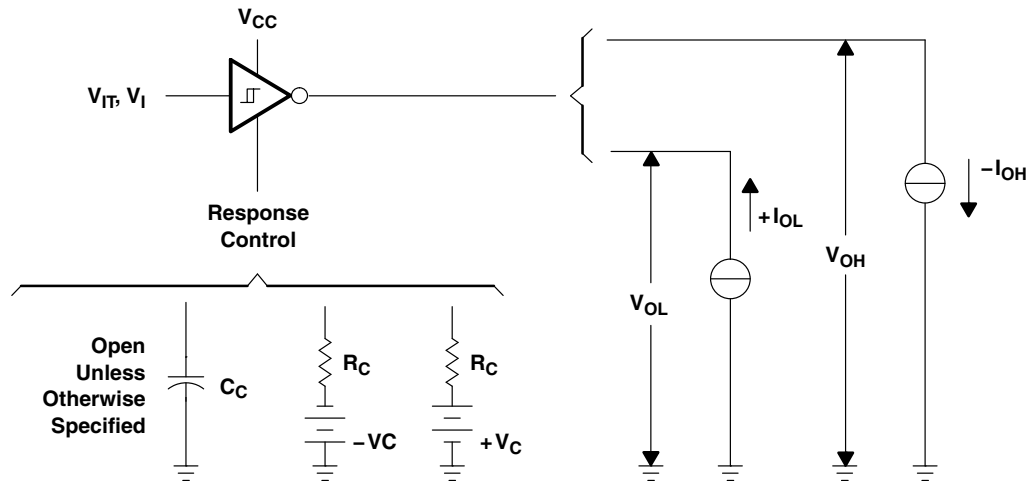
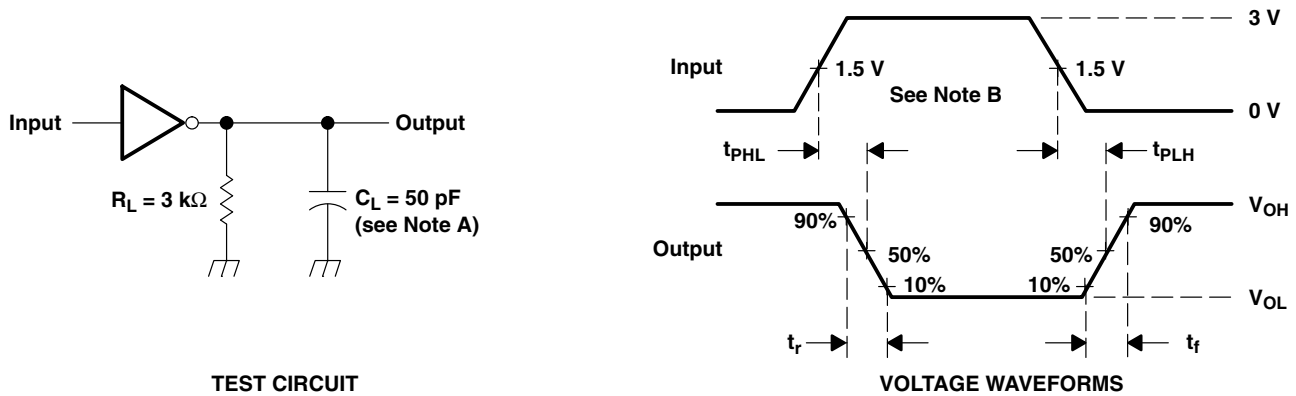

Figure 1. Receiver Section Test Circuit (V_{IT+} , V_{IT-} , V_{OH} , V_{OL})

SN75155 LINE DRIVER AND RECEIVER

SLLS017C – JULY 1986 – REVISED MAY 1995

PARAMETER MEASUREMENT INFORMATION



- NOTES: A. C_L includes probe and jig capacitance.
 B. The input waveform is supplied by a generator with the following characteristics: $Z_O = 50 \Omega$, $t_w = 1 \mu s$, $t_r \leq 10 ns$, $t_f \leq 10 ns$.

Figure 2. Driver Section Switching Test Circuit and Voltage Waveforms

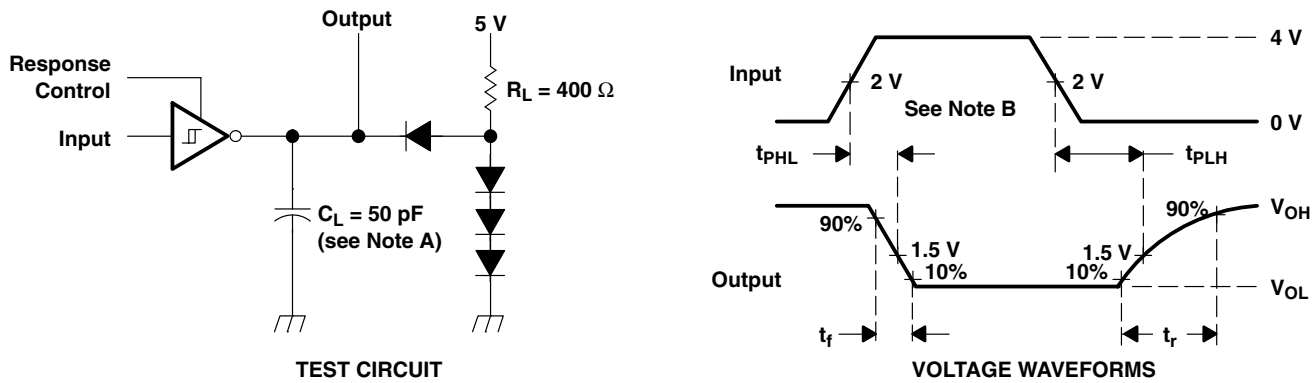

- NOTES: A. C_L includes probe and jig capacitance.
 B. The input waveform is supplied by a generator with the following characteristics: $Z_O = 50 \Omega$, $t_w = 1 \mu s$, $t_r \leq 10 ns$, $t_f \leq 10 ns$.

Figure 3. Receiver Section Switching Test Circuit and Voltage Waveforms

TYPICAL CHARACTERISTICS

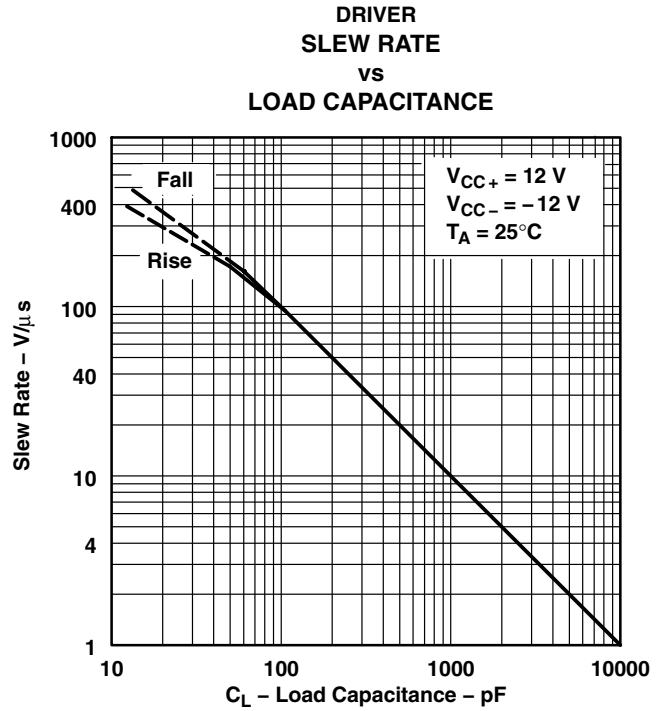
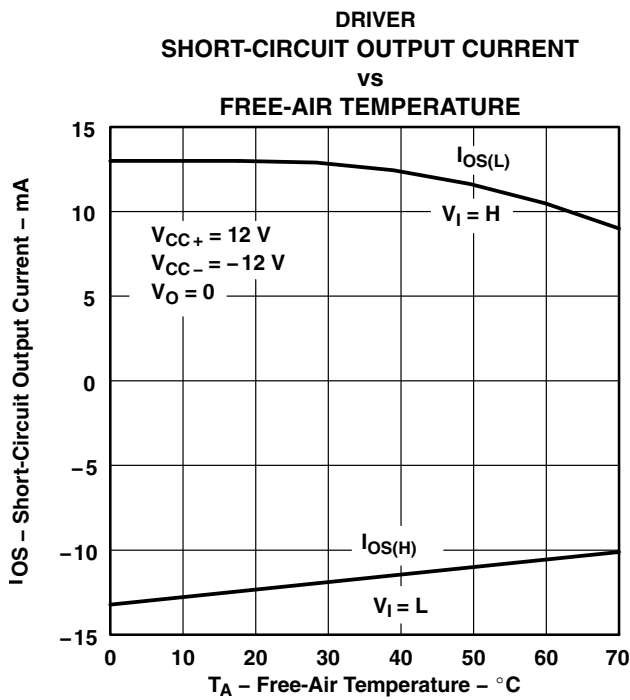
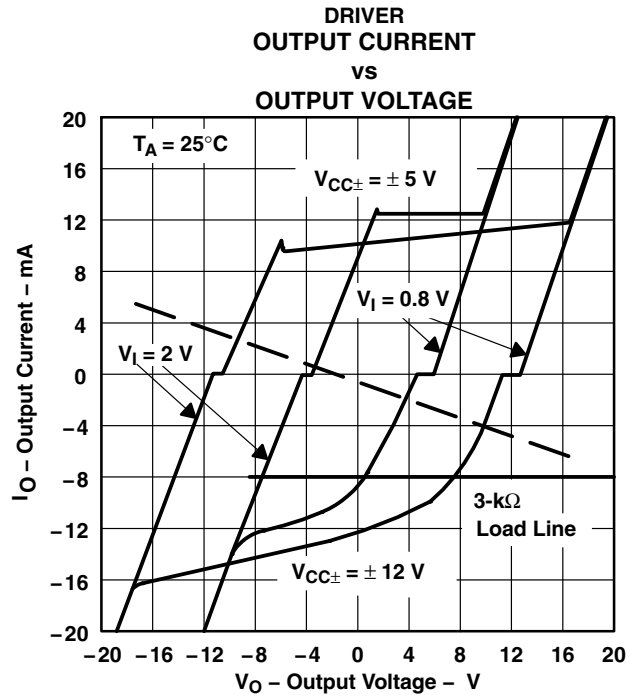
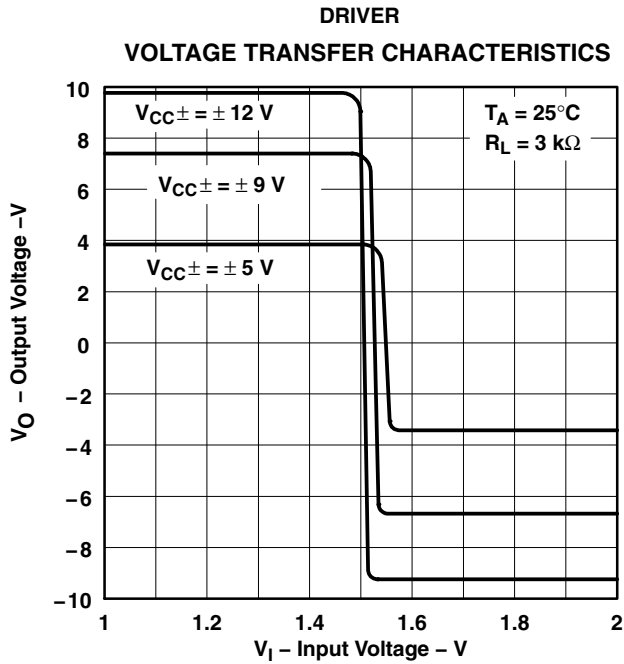

SN75155 LINE DRIVER AND RECEIVER

SLLS017C – JULY 1986 – REVISED MAY 1995

TYPICAL CHARACTERISTICS

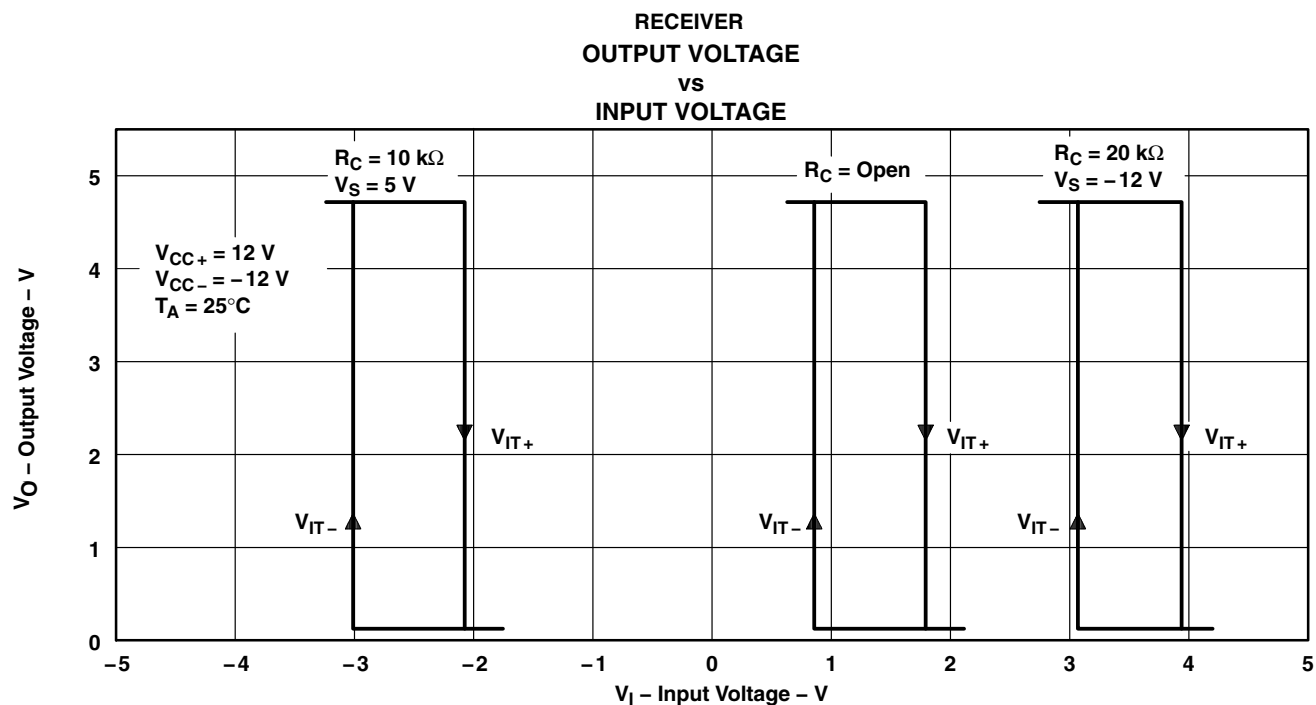
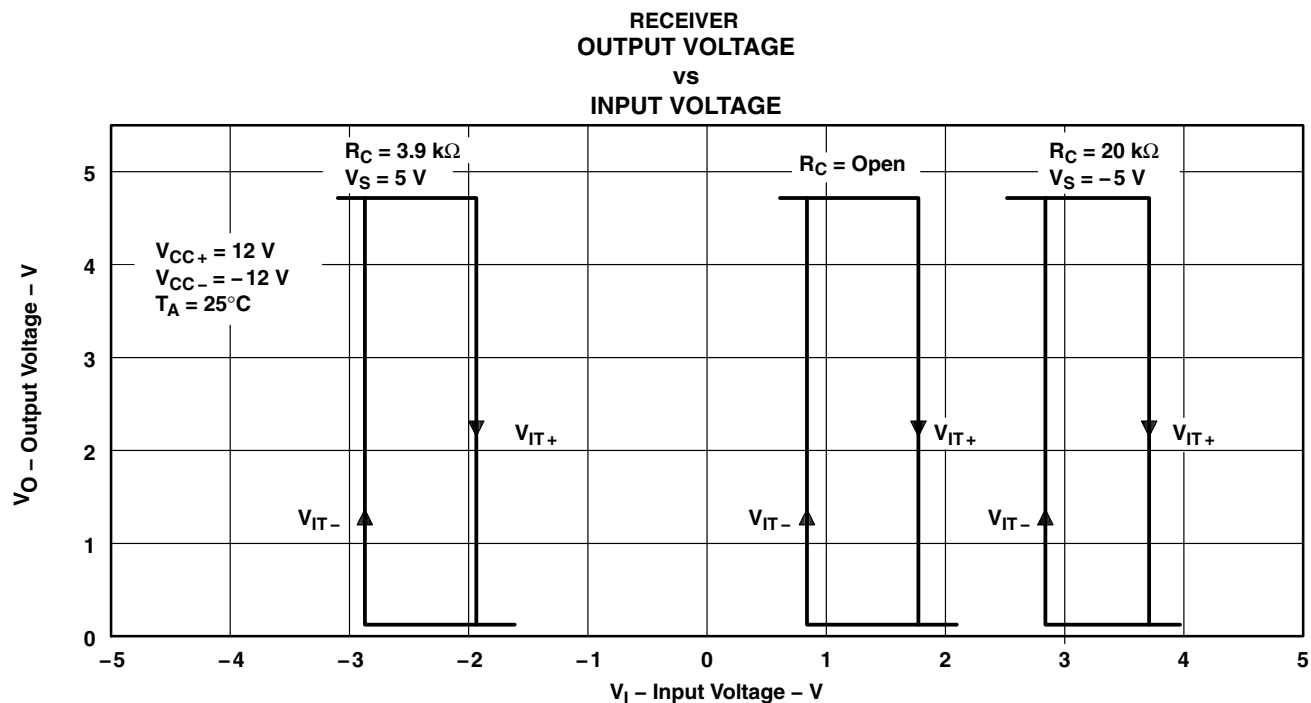

TYPICAL CHARACTERISTICS

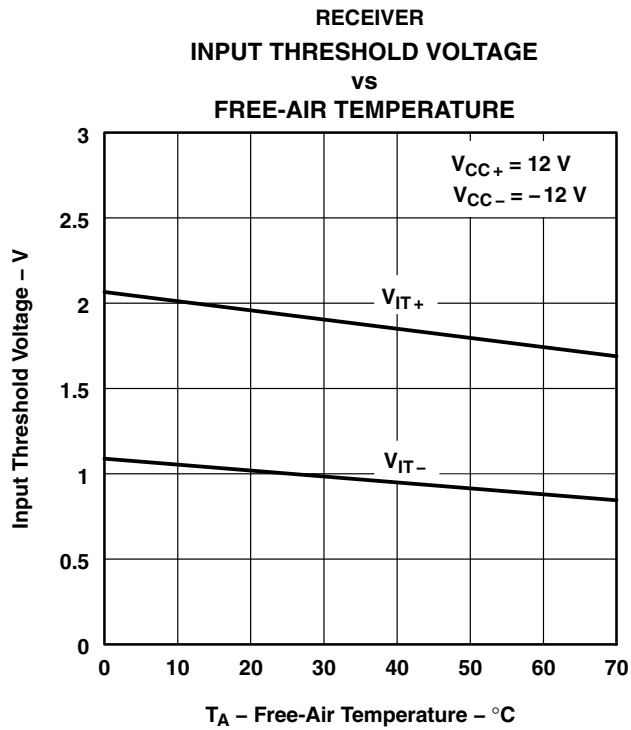

Figure 10

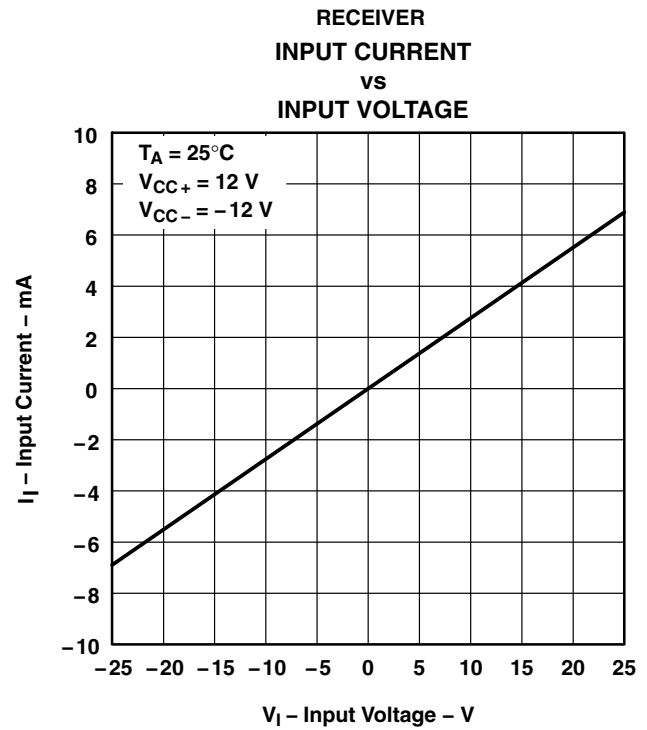

Figure 11

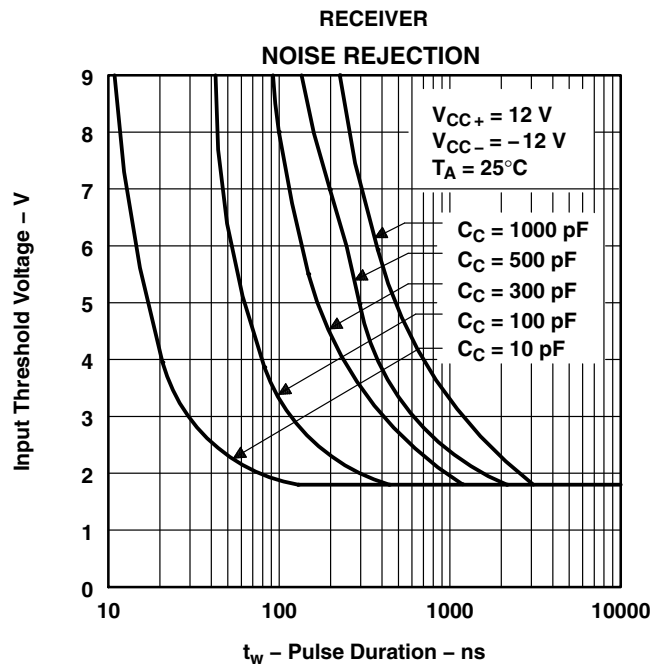

Figure 12

PACKAGING INFORMATION

Orderable Device	Status (1)	Package Type	Package Drawing	Pins	Package Qty	Eco Plan (2)	Lead/Ball Finish (6)	MSL Peak Temp (3)	Op Temp (°C)	Device Marking (4/5)	Samples
SN75155D	ACTIVE	SOIC	D	8	75	Green (RoHS & no Sb/Br)	CU NIPDAU	Level-1-260C-UNLIM	0 to 70	75155	Samples
SN75155DR	ACTIVE	SOIC	D	8	2500	Green (RoHS & no Sb/Br)	CU NIPDAU	Level-1-260C-UNLIM	0 to 70	75155	Samples
SN75155DRE4	ACTIVE	SOIC	D	8	2500	Green (RoHS & no Sb/Br)	CU NIPDAU	Level-1-260C-UNLIM	0 to 70	75155	Samples
SN75155P	ACTIVE	PDIP	P	8	50	Green (RoHS & no Sb/Br)	CU NIPDAU	N / A for Pkg Type	0 to 70	SN75155P	Samples

(1) The marketing status values are defined as follows:

ACTIVE: Product device recommended for new designs.

LIFEBUY: TI has announced that the device will be discontinued, and a lifetime-buy period is in effect.

NRND: Not recommended for new designs. Device is in production to support existing customers, but TI does not recommend using this part in a new design.

PREVIEW: Device has been announced but is not in production. Samples may or may not be available.

OBSOLETE: TI has discontinued the production of the device.

(2) **RoHS:** TI defines "RoHS" to mean semiconductor products that are compliant with the current EU RoHS requirements for all 10 RoHS substances, including the requirement that RoHS substance do not exceed 0.1% by weight in homogeneous materials. Where designed to be soldered at high temperatures, "RoHS" products are suitable for use in specified lead-free processes. TI may reference these types of products as "Pb-Free".

RoHS Exempt: TI defines "RoHS Exempt" to mean products that contain lead but are compliant with EU RoHS pursuant to a specific EU RoHS exemption.

Green: TI defines "Green" to mean the content of Chlorine (Cl) and Bromine (Br) based flame retardants meet JS709B low halogen requirements of <=1000ppm threshold. Antimony trioxide based flame retardants must also meet the <=1000ppm threshold requirement.

(3) MSL, Peak Temp. - The Moisture Sensitivity Level rating according to the JEDEC industry standard classifications, and peak solder temperature.

(4) There may be additional marking, which relates to the logo, the lot trace code information, or the environmental category on the device.

(5) Multiple Device Markings will be inside parentheses. Only one Device Marking contained in parentheses and separated by a "-" will appear on a device. If a line is indented then it is a continuation of the previous line and the two combined represent the entire Device Marking for that device.

(6) Lead/Ball Finish - Orderable Devices may have multiple material finish options. Finish options are separated by a vertical ruled line. Lead/Ball Finish values may wrap to two lines if the finish value exceeds the maximum column width.

Important Information and Disclaimer: The information provided on this page represents TI's knowledge and belief as of the date that it is provided. TI bases its knowledge and belief on information provided by third parties, and makes no representation or warranty as to the accuracy of such information. Efforts are underway to better integrate information from third parties. TI has taken and

continues to take reasonable steps to provide representative and accurate information but may not have conducted destructive testing or chemical analysis on incoming materials and chemicals. TI and TI suppliers consider certain information to be proprietary, and thus CAS numbers and other limited information may not be available for release.

In no event shall TI's liability arising out of such information exceed the total purchase price of the TI part(s) at issue in this document sold by TI to Customer on an annual basis.

TAPE AND REEL INFORMATION



QUADRANT ASSIGNMENTS FOR PIN 1 ORIENTATION IN TAPE



*All dimensions are nominal

Device	Package Type	Package Drawing	Pins	SPQ	Reel Diameter (mm)	Reel Width W1 (mm)	A0 (mm)	B0 (mm)	K0 (mm)	P1 (mm)	W (mm)	Pin1 Quadrant
SN75155DR	SOIC	D	8	2500	330.0	12.4	6.4	5.2	2.1	8.0	12.0	Q1

TAPE AND REEL BOX DIMENSIONS



*All dimensions are nominal

Device	Package Type	Package Drawing	Pins	SPQ	Length (mm)	Width (mm)	Height (mm)
SN75155DR	SOIC	D	8	2500	340.5	338.1	20.6



D0008A

PACKAGE OUTLINE

SOIC - 1.75 mm max height

SMALL OUTLINE INTEGRATED CIRCUIT



NOTES:

1. Linear dimensions are in inches [millimeters]. Dimensions in parenthesis are for reference only. Controlling dimensions are in inches. Dimensioning and tolerancing per ASME Y14.5M.
2. This drawing is subject to change without notice.
3. This dimension does not include mold flash, protrusions, or gate burrs. Mold flash, protrusions, or gate burrs shall not exceed $.006$ [0.15] per side.
4. This dimension does not include interlead flash.
5. Reference JEDEC registration MS-012, variation AA.

EXAMPLE BOARD LAYOUT

D0008A

SOIC - 1.75 mm max height

SMALL OUTLINE INTEGRATED CIRCUIT



LAND PATTERN EXAMPLE
 EXPOSED METAL SHOWN
 SCALE:8X



SOLDER MASK DETAILS

4214825/C 02/2019

NOTES: (continued)

- 6. Publication IPC-7351 may have alternate designs.
- 7. Solder mask tolerances between and around signal pads can vary based on board fabrication site.

EXAMPLE STENCIL DESIGN

D0008A

SOIC - 1.75 mm max height

SMALL OUTLINE INTEGRATED CIRCUIT



SOLDER PASTE EXAMPLE
BASED ON .005 INCH [0.125 MM] THICK STENCIL
SCALE:8X

4214825/C 02/2019

NOTES: (continued)

8. Laser cutting apertures with trapezoidal walls and rounded corners may offer better paste release. IPC-7525 may have alternate design recommendations.
9. Board assembly site may have different recommendations for stencil design.

P (R-PDIP-T8)

PLASTIC DUAL-IN-LINE PACKAGE



- NOTES:
- A. All linear dimensions are in inches (millimeters).
 - B. This drawing is subject to change without notice.
 - C. Falls within JEDEC MS-001 variation BA.

IMPORTANT NOTICE AND DISCLAIMER

TI PROVIDES TECHNICAL AND RELIABILITY DATA (INCLUDING DATASHEETS), DESIGN RESOURCES (INCLUDING REFERENCE DESIGNS), APPLICATION OR OTHER DESIGN ADVICE, WEB TOOLS, SAFETY INFORMATION, AND OTHER RESOURCES "AS IS" AND WITH ALL FAULTS, AND DISCLAIMS ALL WARRANTIES, EXPRESS AND IMPLIED, INCLUDING WITHOUT LIMITATION ANY IMPLIED WARRANTIES OF MERCHANTABILITY, FITNESS FOR A PARTICULAR PURPOSE OR NON-INFRINGEMENT OF THIRD PARTY INTELLECTUAL PROPERTY RIGHTS.

These resources are intended for skilled developers designing with TI products. You are solely responsible for (1) selecting the appropriate TI products for your application, (2) designing, validating and testing your application, and (3) ensuring your application meets applicable standards, and any other safety, security, or other requirements. These resources are subject to change without notice. TI grants you permission to use these resources only for development of an application that uses the TI products described in the resource. Other reproduction and display of these resources is prohibited. No license is granted to any other TI intellectual property right or to any third party intellectual property right. TI disclaims responsibility for, and you will fully indemnify TI and its representatives against, any claims, damages, costs, losses, and liabilities arising out of your use of these resources.

TI's products are provided subject to TI's Terms of Sale (www.ti.com/legal/termsofsale.html) or other applicable terms available either on ti.com or provided in conjunction with such TI products. TI's provision of these resources does not expand or otherwise alter TI's applicable warranties or warranty disclaimers for TI products.

Mailing Address: Texas Instruments, Post Office Box 655303, Dallas, Texas 75265
Copyright © 2019, Texas Instruments Incorporated

Looking for pricing, stock, or lifecycle information?

Click below to explore more details on WIN SOURCE:

 [View SN75155DR on WIN SOURCE](#)

 [Texas Instruments](#) Information

Optimize Your Supply Chain with WIN SOURCE Solutions

-  Global Sourcing Solution
-  Obsolete Management
-  Cost Control Management
-  Shortage Management
-  Alternative Solution
-  Excess Inventory Management