

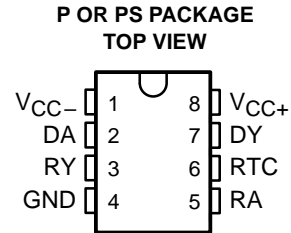

**THE DATASHEET OF
SN751701PSR**



- Meets or Exceeds the Requirements of ANSI TIA/EIA-232-C
- Wide Range of Supply Voltage
 $V_{CC} = \pm 4.5 \text{ V to } \pm 15 \text{ V}$
- Low Power . . . 117 mW ($V_{CC} = \pm 9 \text{ V}$)
- Receiver Output TTL Compatible
- Response Control Provides:
 - Input Threshold Shifting
 - Input Noise Filtering



description

The SN751701 line driver and receiver is designed to satisfy the requirements of the standard interface between data terminal equipment and data communication equipment as defined by ANSI TIA/EIA-232-E. The driver used is similar to the SN75188. The receiver used is similar to the SN75189A. The device operates over a wide range of supply voltages ($V_{CC} = \pm 4.5 \text{ V to } \pm 15 \text{ V}$) from the included reference regulator.

logic diagram

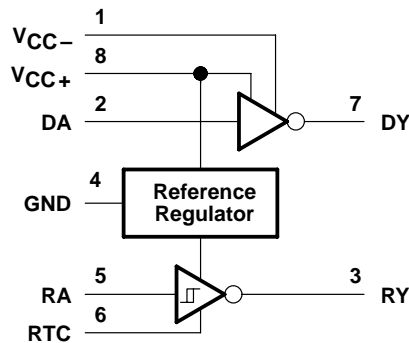

Please be aware that an important notice concerning availability, standard warranty, and use in critical applications of Texas Instruments semiconductor products and disclaimers thereto appears at the end of this data sheet.

SN751701 LINE DRIVER AND RECEIVER

SLLS531 – MARCH 2002

schematic

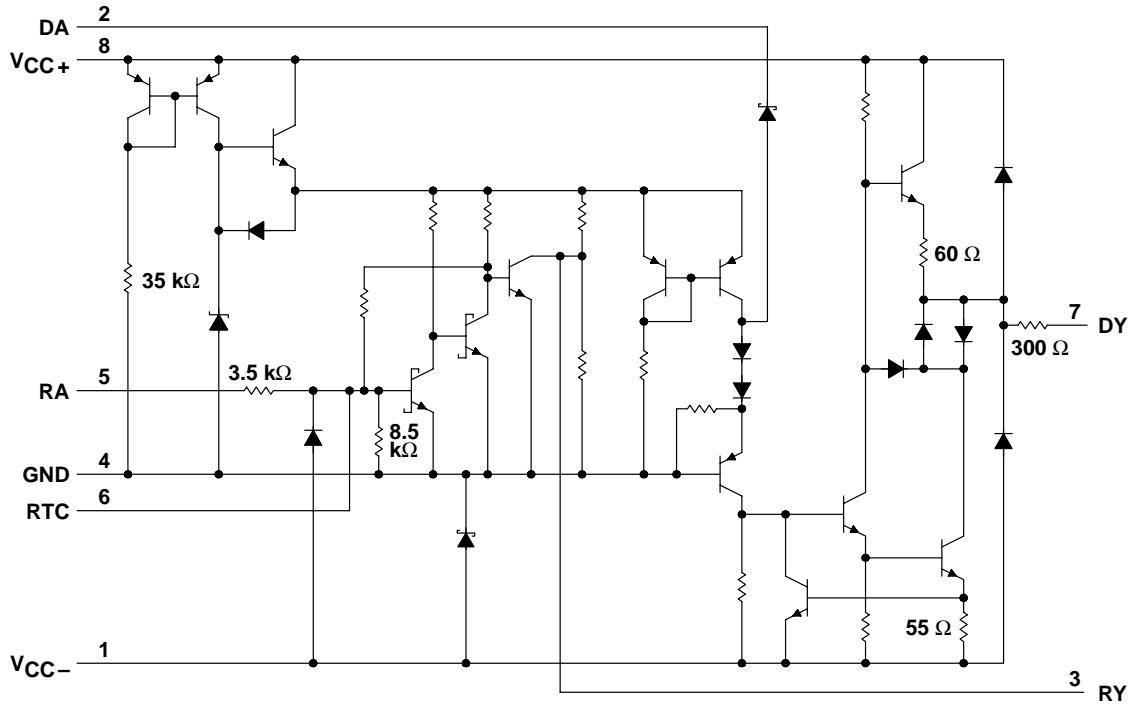

absolute maximum ratings over operating free-air temperature range (unless otherwise noted)†

Supply voltage range, V_{CC+} (see Note 1)	-0.4 V to 18 V
Supply voltage range, V_{CC-} (see Note 1)	0.4 V to -18 V
Input voltage range, V_i : Driver	-5 V to 18 V
Receiver	-30 V to 30 V
Output voltage range, V_o : Driver	-25 V to 25 V
Receiver	-0.4 V to 7 V
Output current, I_o (D) Driver	50 mA
Response control current range, I_{RES}	-10 mA to 10 mA
Continuous total power dissipation	See Dissipation Rating Table
Package thermal impedance, θ_{JA} (see Note 2): P package	85°C/W
PS package	95°C/W
Lead temperature 1,6 mm (1/16 inch) from case for 10 seconds	260°C
Storage temperature range, T_{stg}	-65°C to 150°C

† Stresses beyond those listed under "absolute maximum ratings" may cause permanent damage to the device. These are stress ratings only, and functional operation of the device at these or any other conditions beyond those indicated under "recommended operating conditions" is not implied. Exposure to absolute-maximum-rated conditions for extended periods may affect device reliability.

- NOTES: 1. All voltage values are with respect to the network ground terminal.
2. The package thermal impedance is calculated in accordance with JESD 51-7.

recommended operating conditions

		MIN	MAX	UNIT	
V _{CC+}	Supply voltage	4.5	15	V	
V _{CC-}	Supply voltage	-4.5	-15	V	
V _{I(D)}	Input voltage, driver		15	V	
V _{I(R)}	Input voltage, receiver	-25	25	V	
I _{RESP}	Response control current	-5.5	5.5	mA	
I _{O(R)}	Output current, receiver		24	mA	
T _A	Operating free-air temperature	P package	-20	85	°C
		PS package	-20	70	

electrical characteristics over recommended operating free-air temperature range (unless otherwise noted)

total device

PARAMETER	TEST CONDITIONS		MIN	TYP†	MAX	UNIT
I _{CCH+} High-level supply current	V _{CC} = ±5 V	V _{I(D)} = 2 V, V _{I(R)} = V _{T+(max)} , Output open		6.3	8.1	mA
	V _{CC} = ±9 V			9.1	11.9	
	V _{CC} = ±12 V			10.4	14	
I _{CCL+} Low-level supply current	V _{CC} = ±5 V	V _{I(D)} = 0.8 V, V _{I(R)} = V _{T-(min)} , Output open		2.5	3.4	mA
	V _{CC} = ±9 V			3.7	5.1	
	V _{CC} = ±12 V			4.1	5.6	
I _{CCH-} High-level supply current	V _{CC} = ±5 V	V _{I(D)} = 2 V, V _{I(R)} = V _{T+(max)} , Output open		-2.4	-3.1	mA
	V _{CC} = ±9 V			-3.9	-4.9	
	V _{CC} = ±12 V			-4.8	-6.1	
I _{CCL-} Low-level supply current	V _{CC} = ±5 V	V _{I(D)} = 0.8 V, V _{I(R)} = V _{T-(min)} , Output open		-0.2	-0.35	mA
	V _{CC} = ±9 V			-0.25	-0.4	
	V _{CC} = ±12 V			-0.27	-0.45	
I _{CC+} Positive supply current	V _{CC} = ±5 V	V _{I(R)} = V _{T+(max)} , V _{I(D)} = 0 V, V _{CC-} = 0 V, Output open		4.8	6.4	mA
	V _{CC} = ±12 V			6.7	9.1	

† All typical values are at T_A = 25°C.

SN751701 LINE DRIVER AND RECEIVER

SLLS531 – MARCH 2002

electrical characteristics over recommended operating free-air temperature range, $V_{CC+} = 12\text{ V}$, $V_{CC-} = -12\text{ V}$ (unless otherwise noted)

driver section

PARAMETER		TEST CONDITIONS	MIN	TYP†	MAX	UNIT
V_{IH}	High-level input voltage		2			V
V_{IL}	Low-level input voltage				0.8	V
V_{OH}	High-level output voltage	$V_{I(D)} = 0.8\text{ V}$, $R_L = 3\text{ k}\Omega$	$V_{CC} = \pm 5\text{ V}$	3.2	3.7	V
			$V_{CC} = \pm 9\text{ V}$	6.5	7.2	
			$V_{CC} = \pm 12\text{ V}$	8.9	9.8	
V_{OL}	Low-level output voltage	$V_{I(D)} = 2\text{ V}$, $R_L = 3\text{ k}\Omega$	$V_{CC} = \pm 5\text{ V}$	-3.6	-3.2	V
			$V_{CC} = \pm 9\text{ V}$	-7.1	-6.4	
			$V_{CC} = \pm 12\text{ V}$	-9.7	-8.8	
I_{IH}	High-level input current	$V_{I(D)} = 7\text{ V}$			5	μA
I_{IL}	Low-level input current	$V_{I(D)} = 0\text{ V}$	-0.73	-1.2		mA
$I_{OS(H)}$	High-level short-circuit output current	$V_{I(D)} = 0.8\text{ V}$, $V_{O(D)} = 0\text{ V}$	-7	-12	-14.5	mA
$I_{OS(L)}$	Low-level short-circuit output current	$V_{I(D)} = 2\text{ V}$, $V_{O(D)} = 0\text{ V}$	6.5	11.5	14	mA
r_O	Output resistance	$V_{CC+} = 0\text{ V}$, $V_{O(D)} = -2\text{ V}$ to 2 V	300			Ω

† All typical values are at $T_A = 25^\circ\text{C}$.

switching characteristics, $V_{CC+} = 12\text{ V}$, $V_{CC-} = -12\text{ V}$, $T_A = 25^\circ\text{C}$ (unless otherwise noted)

driver section (see Figure 2)

PARAMETER		TEST CONDITIONS	MIN	TYP	MAX	UNIT
t_{PLH}	Propagation delay time, low- to high-level output	$R_L = 3\text{ k}\Omega$, $C_L = 50\text{ pF}$		340	480	ns
t_{PHL}	Propagation delay time, high- to low-level output			100	150	
t_{TLH}	Transition time, low- to high-level output	$R_L = 3\text{ k}\Omega$, $C_L = 50\text{ pF}$		120	180	ns
t_{THL}	Transition time, high- to low-level output			105	160	
t_{TLH}	Transition time, low- to high-level output	$R_L = 3\text{ k}\Omega$ to $7\text{ k}\Omega$ (see Note 3), $C_L = 2500\text{ pF}$		2.1	3	μs
t_{THL}	Transition time, high- to low-level output			2.1	3	

NOTE 3: The time is measured between 3 V and -3 V on output waveform.



electrical characteristics over recommended operating free-air temperature range, $V_{CC+} = 12\text{ V}$, $V_{CC-} = -12\text{ V}$ (unless otherwise noted)

receiver section (see Figure 1) (see Note 4)

PARAMETER		TEST CONDITIONS	MIN	TYP†	MAX	UNIT	
V_{IT+}	Positive-going input threshold voltage		1.2	1.9	2.3	V	
V_{IT-}	Negative-going input threshold voltage		0.6	0.95	1.2	V	
V_{hys}	Hysteresis voltage ($V_{IT+} - V_{IT-}$)		0.6			V	
$V_{O(H)}$	High-level output voltage	$V_{I(R)} = V_{T-(min)}$, $I_{OL} = -10\ \mu\text{A}$	$V_{CC+} = 5\text{ V}$	3.7	4.1	4.5	V
			$V_{CC+} = 12\text{ V}$	4.4	4.7	5.2	
		$V_{I(R)} = V_{T-(min)}$, $I_{OH} = -0.4\text{ mA}$	$V_{CC+} = 5\text{ V}$	3.1	3.4	3.8	
			$V_{CC+} = 12\text{ V}$	3.6	4	4.5	
$V_{O(L)}$	Low-level output voltage	$V_{I(R)} = V_{T+(max)}$, $I_{OL} = 24\text{ mA}$		0.2	0.3	V	
I_{IH}	High-level input current	$V_{I(R)} = 25\text{ V}$	3.6	6.7	8.3	mA	
		$V_{I(R)} = 3\text{ V}$	0.43	0.67	1	mA	
I_{IL}	Low-level input current	$V_{I(R)} = -25\text{ V}$	-3.6	-6.7	-8.3	mA	
		$V_{I(R)} = -3\text{ V}$	-0.43	-0.74	-1	mA	
I_{OS}	Short-circuit output current	$V_{I(R)} = V_{T-(min)}$		-2.8	-3.7	mA	

† All typical values are at $T_A = 25^\circ\text{C}$.

NOTE 4: Response Control pin is open.

switching characteristics, $V_{CC+} = 12\text{ V}$, $V_{CC-} = -12\text{ V}$, $T_A = 25^\circ\text{C}$ (unless otherwise noted)

receiver section (see Figure 2)

PARAMETER		TEST CONDITIONS	MIN	TYP	MAX	UNIT
t_{PLH}	Propagation delay time, low- to high-level output	$R_L = 400\text{ k}\Omega$, $C_L = 50\text{ pF}$		150	240	ns
t_{PHL}	Propagation delay time, high- to low-level output			50	100	
t_{TLH}	Transition time, low- to high-level output	$R_L = 400\text{ k}\Omega$, $C_L = 50\text{ pF}$		250	360	ns
t_{THL}	Transition time, high- to low-level output			18	35	

PARAMETER MEASUREMENT INFORMATION

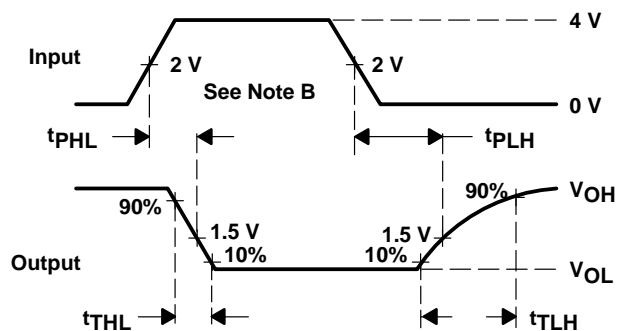
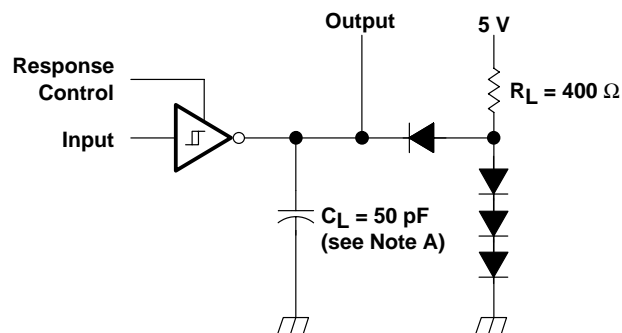

TEST CIRCUIT

VOLTAGE WAVEFORMS

- NOTES: A. C_L includes probe and jig capacitance.
 B. The input waveform is supplied by a generator having the following characteristics: $Z_O = 50 \Omega$, $t_w = 500 \text{ ns}$, $t_{THL} \leq 5 \text{ ns}$, $t_{TLH} \leq 5 \text{ ns}$.

Figure 3. Receiver Section Switching Test Circuit and Voltage Waveforms

TYPICAL CHARACTERISTICS

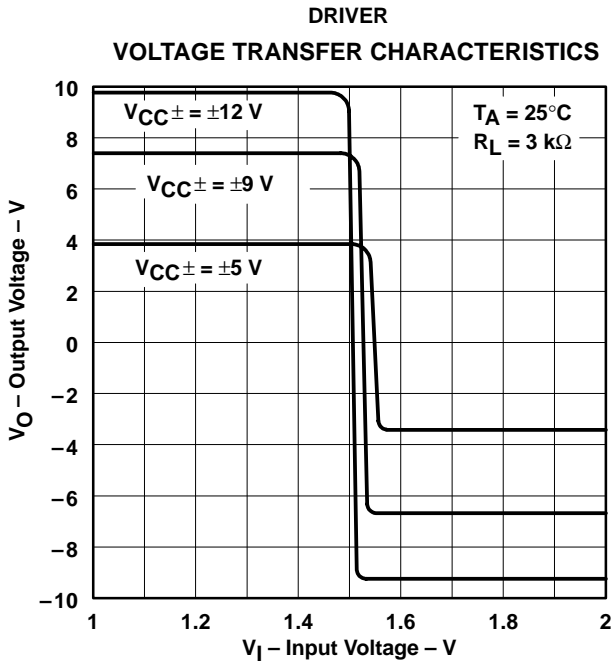

Figure 4

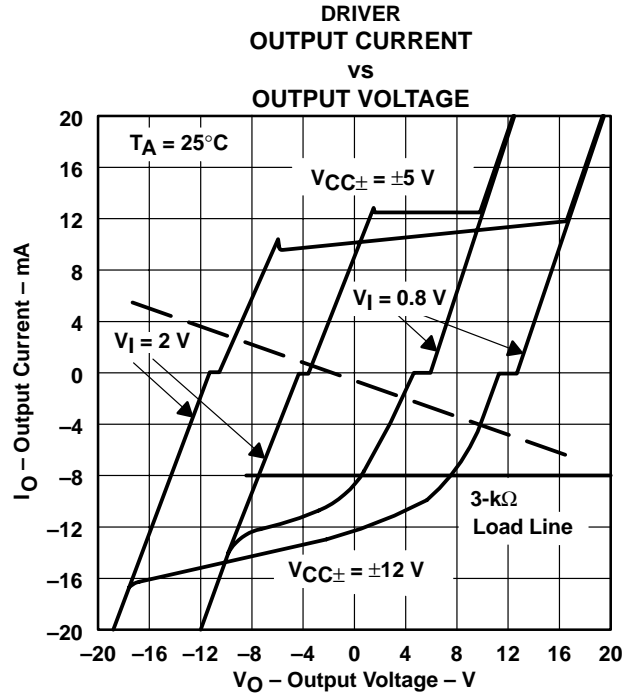

Figure 5

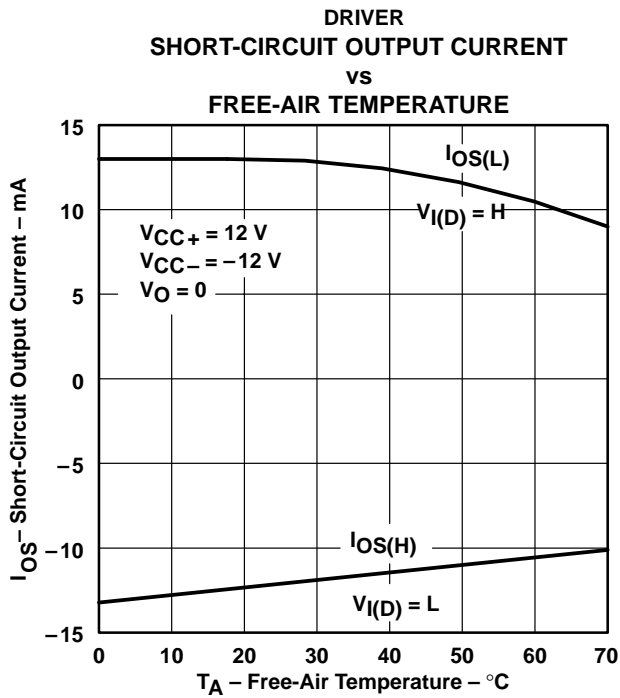

Figure 6

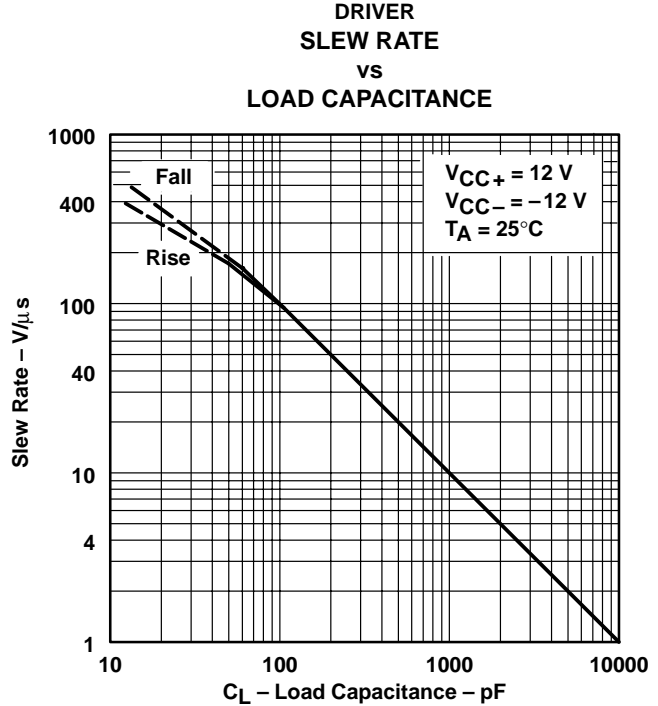
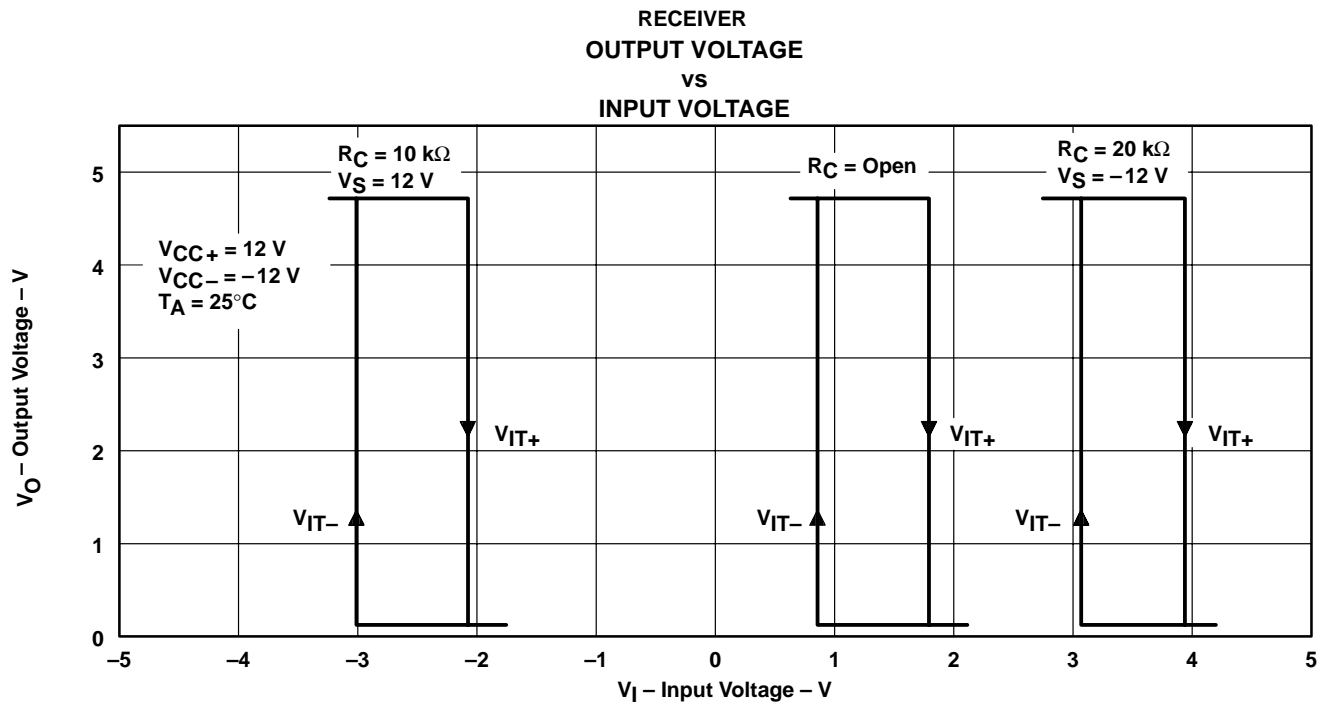
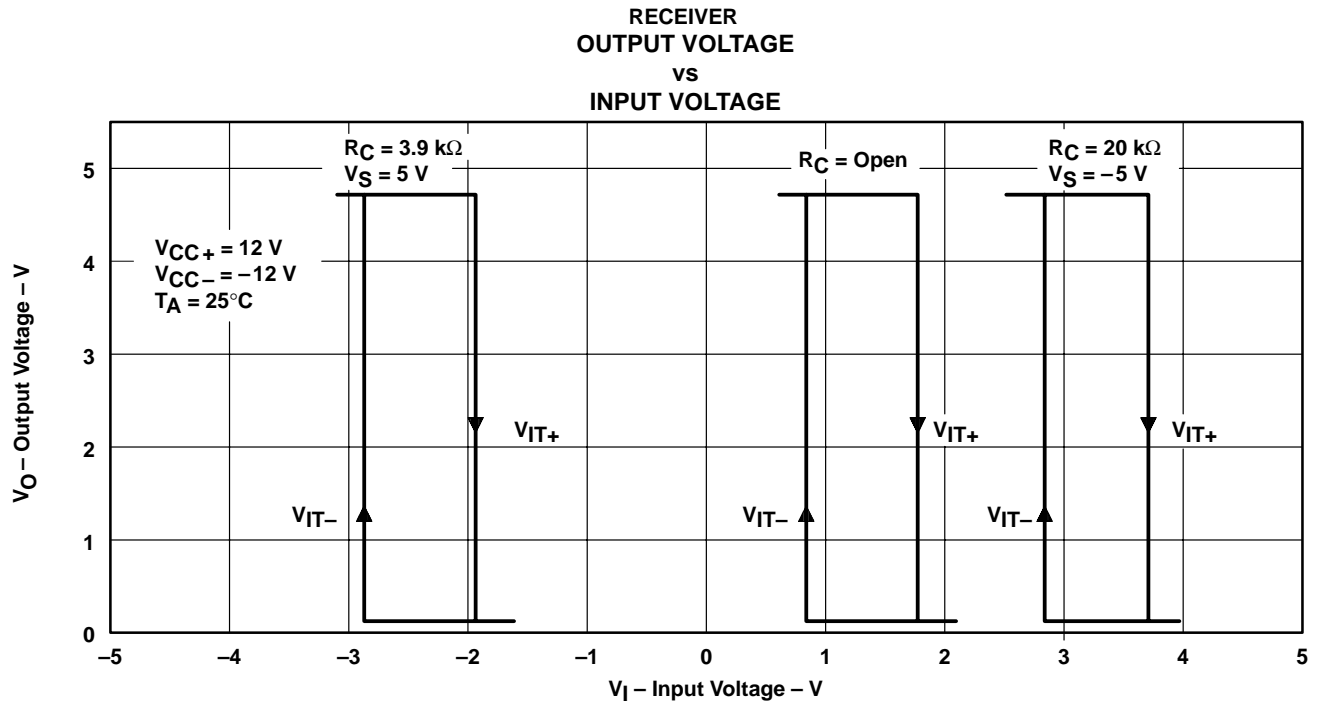
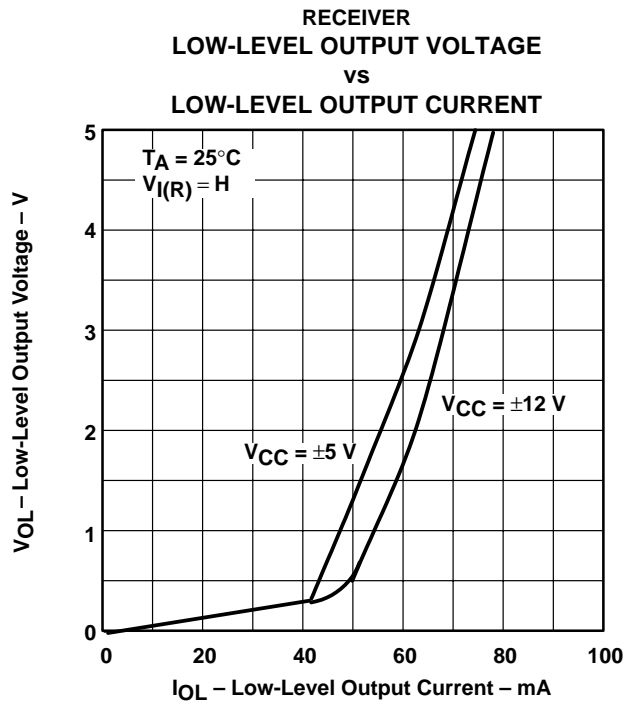
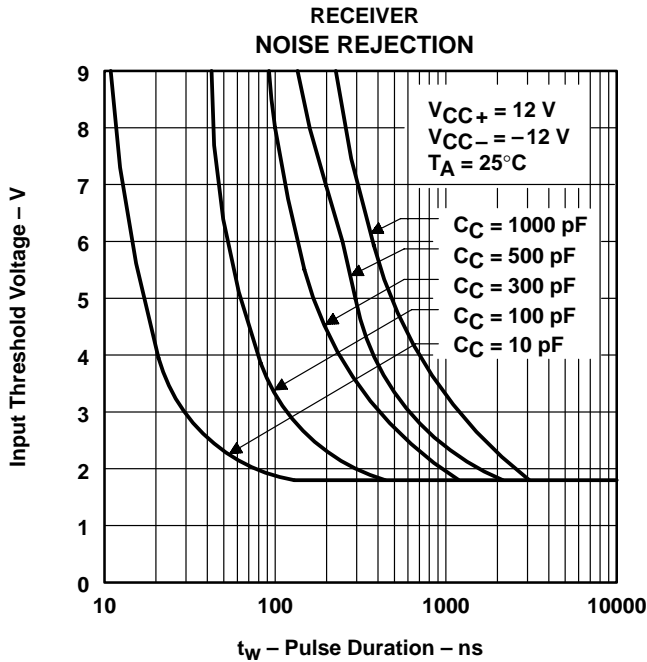
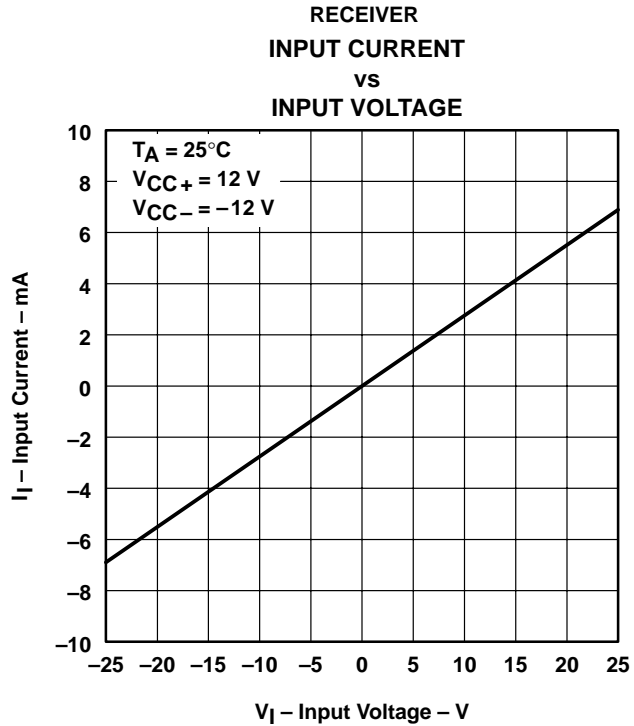
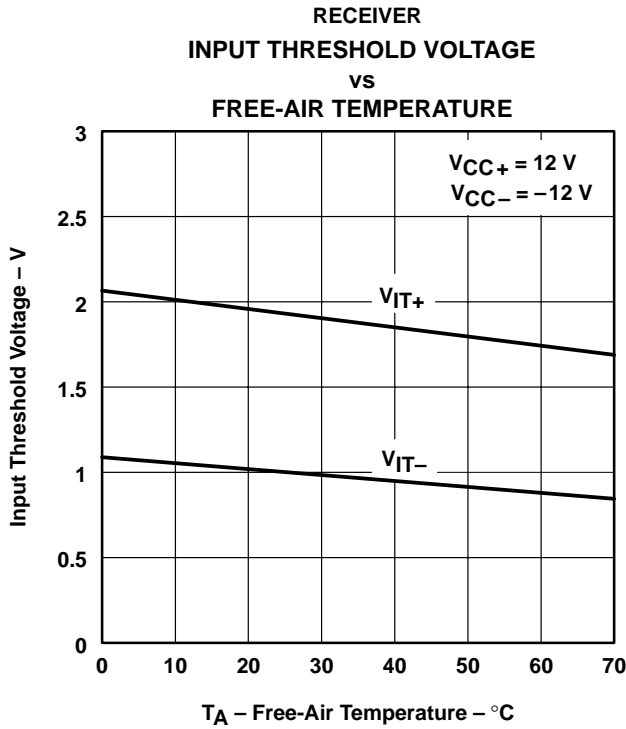

Figure 7

TYPICAL CHARACTERISTICS



TYPICAL CHARACTERISTICS



TYPICAL CHARACTERISTICS

RECEIVER
HIGH-LEVEL OUTPUT VOLTAGE
vs
HIGH-LEVEL OUTPUT CURRENT

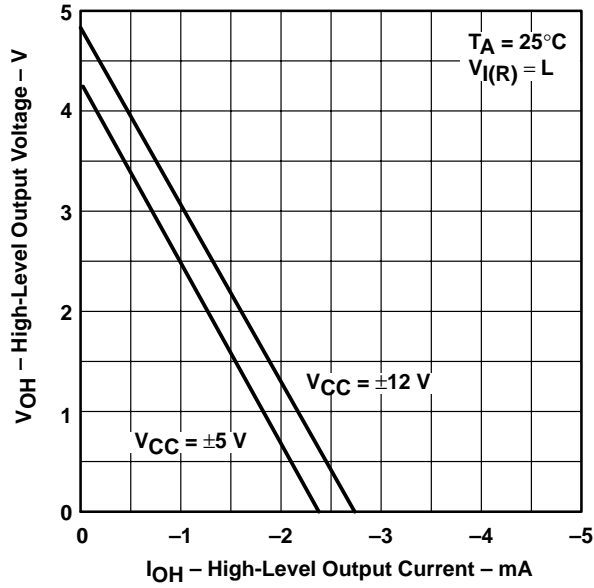

Figure 14

RECEIVER
OUTPUT VOLTAGE
vs
SUPPLY VOLTAGE

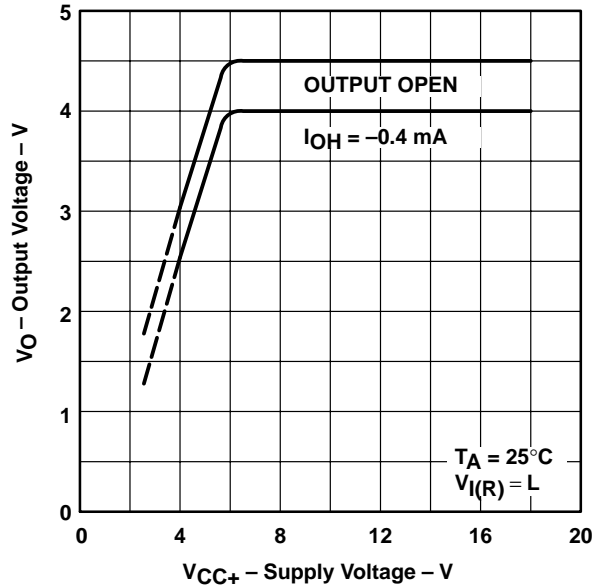

Figure 15

PACKAGING INFORMATION

Orderable Device	Status ⁽¹⁾	Package Type	Package Drawing	Pins	Package Qty	Eco Plan ⁽²⁾	Lead/Ball Finish	MSL Peak Temp ⁽³⁾
SN751701PSR	ACTIVE	SO	PS	8	2000	Green (RoHS & no Sb/Br)	CU NIPDAU	Level-1-260C-UNLIM
SN751701PSRG4	ACTIVE	SO	PS	8	2000	Green (RoHS & no Sb/Br)	CU NIPDAU	Level-1-260C-UNLIM

⁽¹⁾ The marketing status values are defined as follows:

ACTIVE: Product device recommended for new designs.

LIFEBUY: TI has announced that the device will be discontinued, and a lifetime-buy period is in effect.

NRND: Not recommended for new designs. Device is in production to support existing customers, but TI does not recommend using this part in a new design.

PREVIEW: Device has been announced but is not in production. Samples may or may not be available.

OBSELETE: TI has discontinued the production of the device.

⁽²⁾ Eco Plan - The planned eco-friendly classification: Pb-Free (RoHS) or Green (RoHS & no Sb/Br) - please check <http://www.ti.com/productcontent> for the latest availability information and additional product content details.

TBD: The Pb-Free/Green conversion plan has not been defined.

Pb-Free (RoHS): TI's terms "Lead-Free" or "Pb-Free" mean semiconductor products that are compatible with the current RoHS requirements for all 6 substances, including the requirement that lead not exceed 0.1% by weight in homogeneous materials. Where designed to be soldered at high temperatures, TI Pb-Free products are suitable for use in specified lead-free processes.

Green (RoHS & no Sb/Br): TI defines "Green" to mean Pb-Free (RoHS compatible), and free of Bromine (Br) and Antimony (Sb) based flame retardants (Br or Sb do not exceed 0.1% by weight in homogeneous material)

⁽³⁾ MSL, Peak Temp. -- The Moisture Sensitivity Level rating according to the JEDEC industry standard classifications, and peak solder temperature.

Important Information and Disclaimer:The information provided on this page represents TI's knowledge and belief as of the date that it is provided. TI bases its knowledge and belief on information provided by third parties, and makes no representation or warranty as to the accuracy of such information. Efforts are underway to better integrate information from third parties. TI has taken and continues to take reasonable steps to provide representative and accurate information but may not have conducted destructive testing or chemical analysis on incoming materials and chemicals. TI and TI suppliers consider certain information to be proprietary, and thus CAS numbers and other limited information may not be available for release.

In no event shall TI's liability arising out of such information exceed the total purchase price of the TI part(s) at issue in this document sold by TI to Customer on an annual basis.

TAPE AND REEL INFORMATION



QUADRANT ASSIGNMENTS FOR PIN 1 ORIENTATION IN TAPE



*All dimensions are nominal

Device	Package Type	Package Drawing	Pins	SPQ	Reel Diameter (mm)	Reel Width W1 (mm)	A0 (mm)	B0 (mm)	K0 (mm)	P1 (mm)	W (mm)	Pin1 Quadrant
SN751701PSR	SO	PS	8	2000	330.0	16.4	8.2	6.6	2.5	12.0	16.0	Q1

TAPE AND REEL BOX DIMENSIONS



*All dimensions are nominal

Device	Package Type	Package Drawing	Pins	SPQ	Length (mm)	Width (mm)	Height (mm)
SN751701PSR	SO	PS	8	2000	346.0	346.0	33.0

IMPORTANT NOTICE

Texas Instruments Incorporated and its subsidiaries (TI) reserve the right to make corrections, modifications, enhancements, improvements, and other changes to its products and services at any time and to discontinue any product or service without notice. Customers should obtain the latest relevant information before placing orders and should verify that such information is current and complete. All products are sold subject to TI's terms and conditions of sale supplied at the time of order acknowledgment.

TI warrants performance of its hardware products to the specifications applicable at the time of sale in accordance with TI's standard warranty. Testing and other quality control techniques are used to the extent TI deems necessary to support this warranty. Except where mandated by government requirements, testing of all parameters of each product is not necessarily performed.

TI assumes no liability for applications assistance or customer product design. Customers are responsible for their products and applications using TI components. To minimize the risks associated with customer products and applications, customers should provide adequate design and operating safeguards.

TI does not warrant or represent that any license, either express or implied, is granted under any TI patent right, copyright, mask work right, or other TI intellectual property right relating to any combination, machine, or process in which TI products or services are used. Information published by TI regarding third-party products or services does not constitute a license from TI to use such products or services or a warranty or endorsement thereof. Use of such information may require a license from a third party under the patents or other intellectual property of the third party, or a license from TI under the patents or other intellectual property of TI.

Reproduction of TI information in TI data books or data sheets is permissible only if reproduction is without alteration and is accompanied by all associated warranties, conditions, limitations, and notices. Reproduction of this information with alteration is an unfair and deceptive business practice. TI is not responsible or liable for such altered documentation. Information of third parties may be subject to additional restrictions.

Resale of TI products or services with statements different from or beyond the parameters stated by TI for that product or service voids all express and any implied warranties for the associated TI product or service and is an unfair and deceptive business practice. TI is not responsible or liable for any such statements.

TI products are not authorized for use in safety-critical applications (such as life support) where a failure of the TI product would reasonably be expected to cause severe personal injury or death, unless officers of the parties have executed an agreement specifically governing such use. Buyers represent that they have all necessary expertise in the safety and regulatory ramifications of their applications, and acknowledge and agree that they are solely responsible for all legal, regulatory and safety-related requirements concerning their products and any use of TI products in such safety-critical applications, notwithstanding any applications-related information or support that may be provided by TI. Further, Buyers must fully indemnify TI and its representatives against any damages arising out of the use of TI products in such safety-critical applications.

TI products are neither designed nor intended for use in military/aerospace applications or environments unless the TI products are specifically designated by TI as military-grade or "enhanced plastic." Only products designated by TI as military-grade meet military specifications. Buyers acknowledge and agree that any such use of TI products which TI has not designated as military-grade is solely at the Buyer's risk, and that they are solely responsible for compliance with all legal and regulatory requirements in connection with such use.

TI products are neither designed nor intended for use in automotive applications or environments unless the specific TI products are designated by TI as compliant with ISO/TS 16949 requirements. Buyers acknowledge and agree that, if they use any non-designated products in automotive applications, TI will not be responsible for any failure to meet such requirements.

Following are URLs where you can obtain information on other Texas Instruments products and application solutions:

Products

Amplifiers	amplifier.ti.com
Data Converters	dataconverter.ti.com
DSP	dsp.ti.com
Clocks and Timers	www.ti.com/clocks
Interface	interface.ti.com
Logic	logic.ti.com
Power Mgmt	power.ti.com
Microcontrollers	microcontroller.ti.com
RFID	www.ti-rfid.com
RF/IF and ZigBee® Solutions	www.ti.com/lprf

Applications

Audio	www.ti.com/audio
Automotive	www.ti.com/automotive
Broadband	www.ti.com/broadband
Digital Control	www.ti.com/digitalcontrol
Medical	www.ti.com/medical
Military	www.ti.com/military
Optical Networking	www.ti.com/opticalnetwork
Security	www.ti.com/security
Telephony	www.ti.com/telephony
Video & Imaging	www.ti.com/video
Wireless	www.ti.com/wireless

Mailing Address: Texas Instruments, Post Office Box 655303, Dallas, Texas 75265
Copyright © 2008, Texas Instruments Incorporated

Looking for pricing, stock, or lifecycle information?

Click below to explore more details on WIN SOURCE:

 [View SN751701PSR on WIN SOURCE](#)

 [Texas Instruments](#) Information

Optimize Your Supply Chain with WIN SOURCE Solutions

-  Global Sourcing Solution
-  Obsolete Management
-  Cost Control Management
-  Shortage Management
-  Alternative Solution
-  Excess Inventory Management