



**THE DATASHEET OF
SN75179BDRG4**



SN75179B Differential Driver and Receiver Pair

1 Features

- Meets or exceeds the requirements of TIA/EIA-422-B, TIA/EIA-485-A, and ITU Recommendation V.11
- Bus voltage range: -7 V to 12 V
- Positive- and negative-current limiting
- Driver output capability: 60 mA Max
- Driver thermal-shutdown protection
- Receiver input impedance: $12\text{ k}\Omega$ Min
- Receiver input sensitivity: $\pm 200\text{ mV}$
- Receiver input hysteresis: 50 mV Typ
- Operates from single 5-V supply
- Low power requirements

2 Description

The SN75179B is a differential driver and receiver pair designed for balanced transmission-line applications and meets TIA/EIA-422-B, TIA/EIA-485-A, and ITU Recommendation V.11. The device is designed to improve the performance of full-duplex data communications over long bus lines.

The SN75179B driver output provides limiting for both positive and negative currents. The receiver features high input impedance, input hysteresis for increased noise immunity, and input sensitivity of $\pm 200\text{ mV}$ over a common-mode input voltage range of -7 V to 12 V . The driver provides thermal shutdown for protection from line fault conditions. Thermal shutdown is designed to occur at a junction temperature of approximately 150°C . The SN75179B is designed to drive current loads of up to 60 mA maximum.

The SN75179B is characterized for operation from 0°C to 70°C .

Package Information

PART NUMBER	PACKAGE ⁽¹⁾	BODY SIZE (NOM)
SN75179B	D (SOIC)	4.9 mm x 3.91 mm
	P (PDIP)	9.81 mm x 9.43 mm
	PS (SOP)	6.2 mm x 5.3 mm

(1) For all available packages, see the orderable addendum at the end of the data sheet.

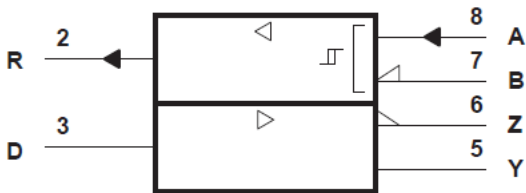

A. This symbol is in accordance with ANSI/IEEE Std 91-1984 and IEC Publication 617-12.

Logic Symbol

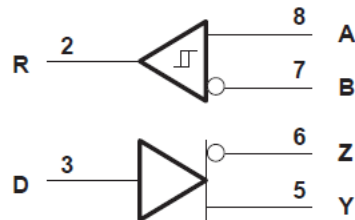

Logic Diagram (Positive Logic)

Table of Contents

1 Features	1	5.9 Typical Characteristics.....	7
2 Description	1	6 Parameter Measurement Information	9
3 Revision History	2	7 Detailed Description	10
4 Pin Configuration and Functions	3	7.1 Functional Block Diagram.....	10
5 Specifications	4	7.2 Device Functional Modes.....	11
5.1 Absolute Maximum Ratings.....	4	8 Device and Documentation Support	12
5.2 Recommended Operating Conditions.....	4	8.1 Documentation Support.....	12
5.3 Thermal Information.....	4	8.2 Receiving Notification of Documentation Updates...	12
5.4 Electrical Characteristics: Driver.....	5	8.3 Support Resources.....	12
5.5 Switching Characteristics.....	5	8.4 Trademarks.....	12
5.6 Symbol Equivalent.....	5	8.5 Electrostatic Discharge Caution.....	12
5.7 Electrical Characteristics: Receiver.....	6	8.6 Glossary.....	12
5.8 Switching Characteristics	6	9 Mechanical, Packaging, and Orderable Information..	12

3 Revision History

NOTE: Page numbers for previous revisions may differ from page numbers in the current version.

Changes from Revision E (June 2008) to Revision F (October 2022)	Page
• Changed the data sheet format to the latest data sheet format.....	1
• Changed the <i>Thermal Information</i> table.....	4

4 Pin Configuration and Functions

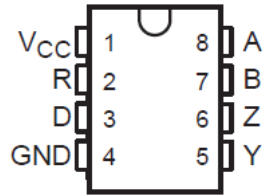

**Figure 4-1. D, PS, or P Package
Top View**

Table 4-1. Pin Functions

PIN		TYPE ⁽¹⁾	DESCRIPTION
NAME	NO.		
1	V _{CC}	P	5V Voltage Supply
2	R	O	RS485 Logic Output
3	D	I	RS485 Logic Input
4	GND	G	Ground
5	Y	O	Non-Inverting RS485 Bus Output
6	Z	O	Inverted RS485 Bus Output
7	B	I	Inverted RS485 Bus Input
8	A	I	Non-Inverting RS485 Bus Input

(1) I = Input, O = Output, I/O = Input or Output, G = Ground, P = Power.

5 Specifications

5.1 Absolute Maximum Ratings

over operating free-air temperature range (unless otherwise noted)⁽¹⁾

		MIN	MAX	UNIT
V _{CC}	Supply voltage ⁽²⁾		7	V
	Voltage range at any bus terminal	-10	15	V
V _{ID}	Differential input voltage ⁽³⁾		±25	V
T _{stg}	Storage temperature	-65	150	°C

- (1) Stresses beyond those listed under *Absolute Maximum Ratings* may cause permanent damage to the device. These are stress ratings only, which do not imply functional operation of the device at these or any other conditions beyond those indicated under *Recommended Operating Conditions*. Exposure to absolute-maximum-rated conditions for extended periods may affect device reliability.
- (2) All voltage values are with respect to network ground terminal.
- (3) Differential input voltage is measured at the noninverting input with respect to the corresponding inverting input.

5.2 Recommended Operating Conditions

over operating free-air temperature range (unless otherwise noted)

			MIN	NOM	MAX	UNIT
V _{CC}	Supply voltage		4.75	5	5.25	V
V _{IH}	High-level input voltage	Driver	2			V
V _{IL}	Low-level input voltage	Driver			0.8	V
V _{IC}	Common-mode input voltage		-7 ⁽¹⁾		12	V
V _{ID}	Differential input voltage,				±12	V
I _{OH}	High level output current	Driver			-602	mA
		Receiver			-400	µA
I _{OL}	Low level output current	Driver			60	mA
		Receiver			8	mA
T _A	Operating free-air temperature		0		70	°C

- (1) The algebraic convention, where the less positive (more negative) limit is designated minimum, is used in this data sheet for common-mode input voltage and threshold voltage.

5.3 Thermal Information

THERMAL METRIC ⁽¹⁾		SOIC (D)	PDIP (P)	SOP (PS)	UNIT
		8 PINS	8 PINS	8 PINS	
R _{θJA}	Junction-to-ambient thermal resistance	116.7	109.5	84.3	°C/W
R _{θJC(top)}	Junction-to-case (top) thermal resistance	56.3	53.9	65.4	
R _{θJB}	Junction-to-board thermal resistance	63.4	65.7	62.1	
ψ _{JT}	Junction-to-top characterization parameter	8.8	11.6	31.3	
ψ _{JB}	Junction-to-board characterization parameter	62.6	64.5	60.4	
R _{θJC(bot)}	Junction-to-case (bottom) thermal resistance	N/A	N/A	N/A	

- (1) For more information about traditional and new thermal metrics, see the [Semiconductor and IC package thermal metrics](#) application report.

5.4 Electrical Characteristics: Driver

over recommended ranges of supply voltage and operating free-air temperature (unless otherwise noted)

PARAMETER		TEST CONDITIONS		MIN	TYP ⁽¹⁾	MAX	UNIT
V _{IK}	Input clamp voltage	I _I = -18 mA				-1.5	V
V _O	Output voltage	I _O = 0		0		6	V
V _{OD1}	Differential output voltage	I _O = 0		1.5		6	V
V _{OD2}	Differential output voltage	R _L = 100 Ω	See Figure 6-1	1/2 V _{OD1}			V
		R _L = 54 Ω	See Figure 6-1	1.5	2.5	5	
V _{OD3}	Differential output voltage	See ⁽⁴⁾		1.5		5	V
Δ V _{OD}	Change in magnitude of differential output voltage					±0.2	V
V _{OC}	Common mode output voltage	R _L = 54 Ω or 100 Ω,	See Figure 6-1	3			V
				-1			
Δ V _{OC}	Change in magnitude of common-mode output voltage ⁽³⁾					±0.2	V
I _O	Output current	V _{CC} = 0	V _O = -7 V to 12 V			±100	μA
I _{IH}	High-level input current	V _{IH} = 2.4 V				20	μA
I _{IL}	Low-level input current	V _{IL} = 0.4 V				-200	μA
I _{OS}	Short circuit output current	V _O = -7 V				-250	mA
		V _O = V _{CC}				250	
		V _O = 12 V				250	
I _{CC}	Supply current (total package)	No load			57	70	mA

(1) All typical values are at V_{CC} = 5 V and T_A = 25°C.

(2) The minimum V_{OD2} with 100-Ω load is either 1/2 V_{OD1} or 2 V, whichever is greater

(3) Δ|V_{OD}| and Δ|V_{OC}| are the changes in magnitude of V_{OD} and V_{OC}, respectively, that occur when the input is changed from a high level to a low level.

(4) See TIA/EIA-485-A, Figure 3.5, Test Termination Measurement 2.

5.5 Switching Characteristics

V_{CC} = 5 V, T_A = 25°C

PARAMETER	TEST CONDITIONS	MIN	TYP	MAX	UNIT
t _{d(OD)}	R _L = 54 Ω, See Figure 6-3		15	22	ns
t _{t(OD)}	R _L = 54 Ω, See Figure 6-3		20	30	ns

5.6 Symbol Equivalent

DATA-SHEET PARAMETER	TIA/EIA-422-B	TIA/EIA-485-A
V _O	V _{oa} , V _{ob}	V _{oa} , V _{ob}
V _{OD1}	V _o	V _o
V _{OD2}	V _t (R _L = 100 Ω)	V _t (R _L = 54 Ω)
V _{OD3}		V _t (Test Termination Measurement 2)
D V _{OD}	V _t - V _t	V _t - V _t
V _{OC}	V _{os}	V _{os}
D V _{OC}	V _{os} - V _{os}	V _{os} - V _{os}
I _{OS}	I _{sa} , I _{sb}	
I _O	I _{xa} , I _{xb}	I _{ia} , I _{ib}

5.7 Electrical Characteristics: Receiver

over recommended ranges of supply voltage and operating free-air temperature (unless otherwise noted)

PARAMETER		TEST CONDITIONS			MIN	TYP ⁽¹⁾	MAX	UNIT
V_{IT+}	Positive-going input threshold voltage	$V_O = 2.7$ V	$I_O = -0.4$ mA				0.2	V
V_{IT-}	Negative-going input threshold voltage	$V_O = 0.5$ V	$I_O = 8$ mA		-0.2 ⁽²⁾			V
V_{hys}	Hysteresis voltage ($V_{IT+} - V_{IT-}$)					50		mV
V_{OH}	High-level output voltage	$V_{ID} = 200$ mV	$I_{OH} = -400$ μ A	See Figure 6-2	2.7			V
V_{OL}	Low-level output voltage	$V_{ID} = -200$ mV	$I_{OL} = 8$ mA	See Figure 6-2			0.45	V
I_I	Line input current	Other input at 0 V	See ⁽³⁾	$V_I = 12$ V			1	mA
				$V_I = -7$ V			-0.8	mA
r_I	Input resistance				12			k Ω
I_{OS}	Short-circuit output current				-15		-85	mA
I_{OS}	Supply current (total package)	No load				57	70	mA

(1) All typical values are at $V_{CC} = 5$ V and $T_A = 25^\circ\text{C}$.

(2) The algebraic convention, where the less positive (more negative) limit is designated minimum, is used in this data sheet for common-mode input voltage and threshold voltage levels only.

(3) See TIA/EIA-422-B for exact conditions.

5.8 Switching Characteristics

$V_{CC} = 5$ V, $T_A = 25^\circ\text{C}$

PARAMETER		TEST CONDITIONS		MIN	TYP	MAX	UNIT
t_{PLH}	Propagation delay time, low- to high-level output	$V_{ID} = -1.5$ V to 1.5 V			19	35	ns
t_{PHL}	Propagation delay time, high- to low-level output	$C_L = 15$ pF	See Figure 6-4		30	40	ns

5.9 Typical Characteristics

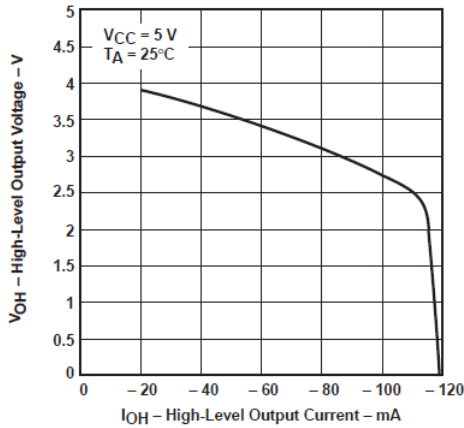

Figure 5-1. Driver High-Level Output Voltage vs High-Level Output Current

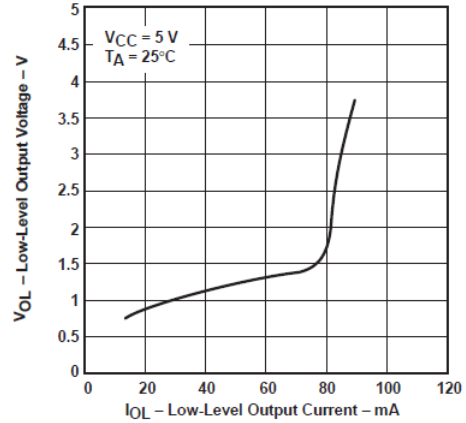

Figure 5-2. Driver Low-Level Output Voltage vs Low-Level Output Current

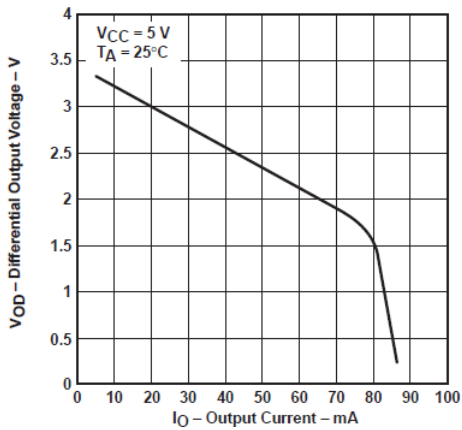

Figure 5-3. Driver Differential Output Voltage vs Output Current

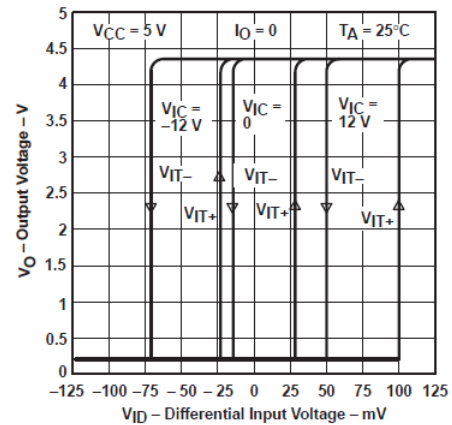

Figure 5-4. Receiver Output Voltage vs Differential Input Voltage

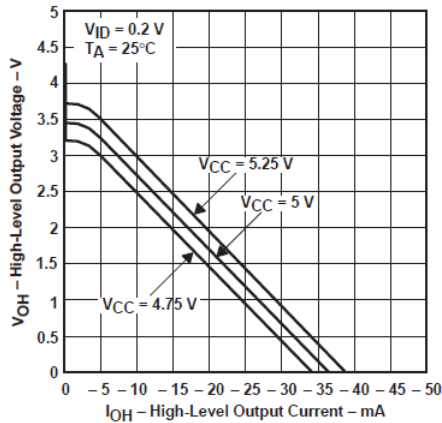

Figure 5-5. High-Level Output Voltage vs High-Level Output Current

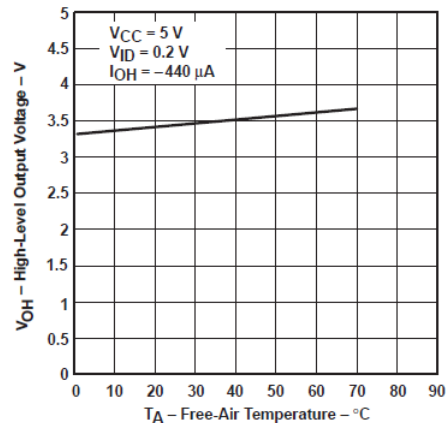

Figure 5-6. High-Level Output Voltage vs Free-Air Temperature

5.9 Typical Characteristics (continued)

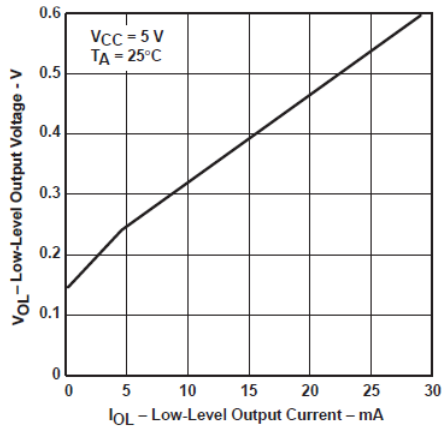

Figure 5-7. Receiver Low-Level Output Voltage vs Low-Level Output Current

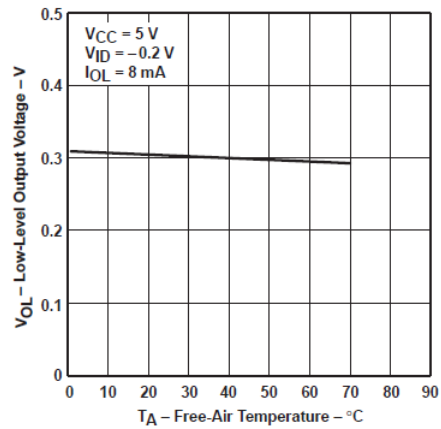

Figure 5-8. Receiver Low-Level Output Voltage vs Free-Air Temperature

6 Parameter Measurement Information

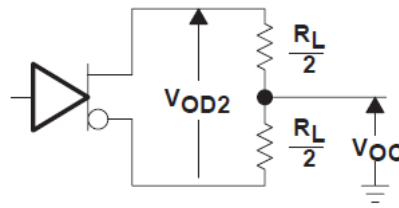

Figure 6-1. Driver V_{DD} and V_{OC}

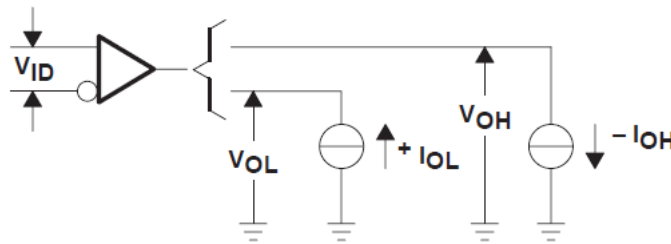
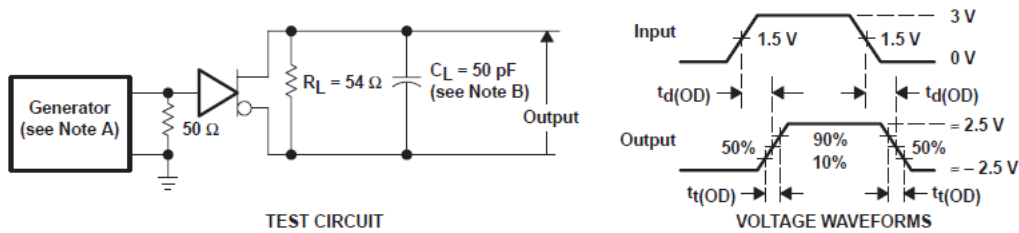
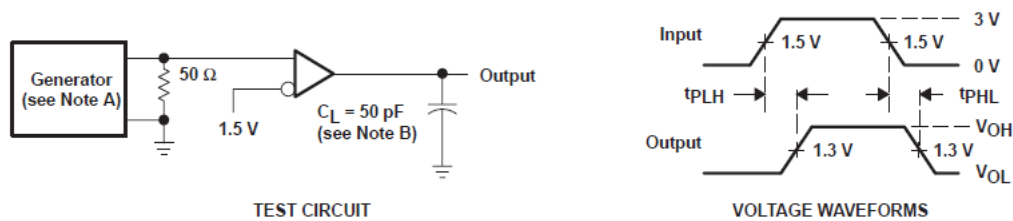

Figure 6-2. Receiver V_{OH} and V_{OL}



- A. The input pulse is supplied by a generator having the following characteristics: $PRR \leq 1$ MHz, 50% duty cycle, $t_r \leq 6$ ns, $t_f \leq 6$ ns, $Z_0 = 50 \Omega$.
- B. C_L includes probe and jig capacitance.

Figure 6-3. Driver Test Circuit and Voltage Waveforms



- A. The input pulse is supplied by a generator having the following characteristics: $PRR \leq 1$ MHz, 50% duty cycle, $t_r \leq 6$ ns, $t_f \leq 6$ ns, $Z_0 = 50 \Omega$.
- B. C_L includes probe and jig capacitance.

Figure 6-4. Receiver Test Circuit and Voltage Waveforms

7 Detailed Description

7.1 Functional Block Diagram

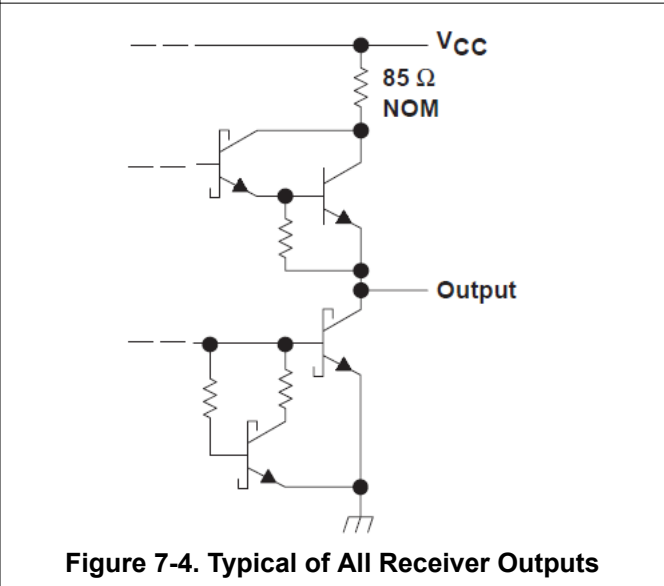
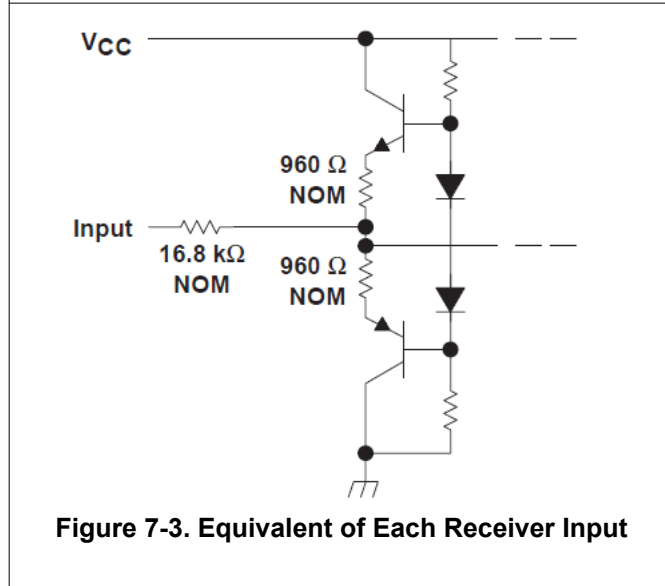
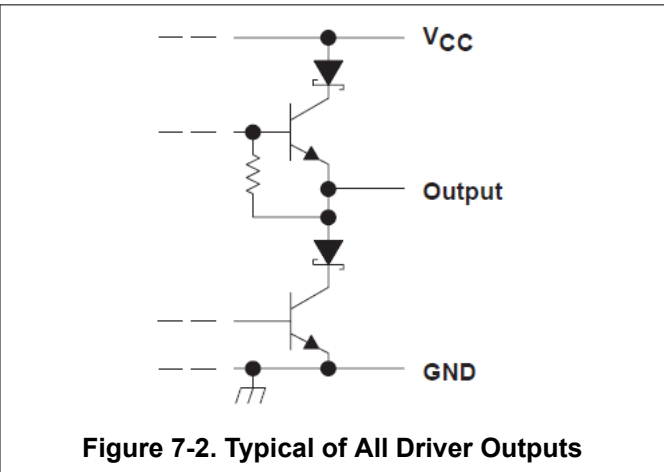
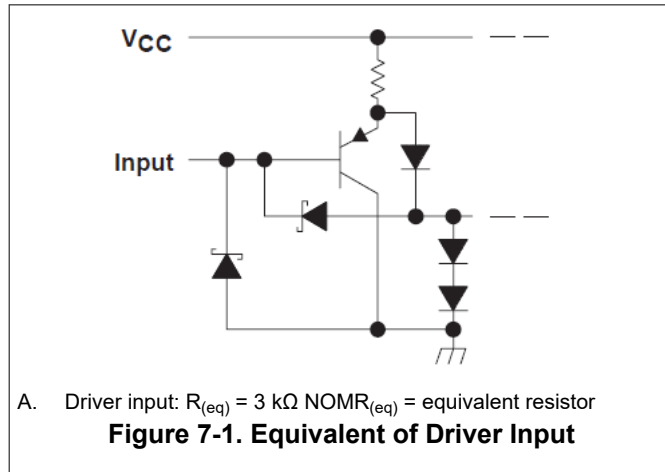

7.2 Device Functional Modes

Table 7-1. Driver⁽¹⁾

INPUT D	OUTPUTS	
	Y	Z
H	H	L
L	L	H

(1) H = high level, L = low level, ? = indeterminate

Table 7-2. Receiver⁽¹⁾

DIFFERENTIAL INPUTS A – B	OUTPUT R
$V_{ID} \geq 0.2 \text{ V}$	H
$-0.2 \text{ V} < V_{ID} < 0.2 \text{ V}$?
$V_{ID} \leq -0.2 \text{ V}$	L
Open	?

(1) H = high level, L = low level, ? = indeterminate

8 Device and Documentation Support

TI offers an extensive line of development tools. Tools and software to evaluate the performance of the device, generate code, and develop solutions are listed below.

8.1 Documentation Support

8.1.1 Related Documentation

8.2 Receiving Notification of Documentation Updates

To receive notification of documentation updates, navigate to the device product folder on ti.com. Click on *Subscribe to updates* to register and receive a weekly digest of any product information that has changed. For change details, review the revision history included in any revised document.

8.3 Support Resources

[TI E2E™ support forums](#) are an engineer's go-to source for fast, verified answers and design help — straight from the experts. Search existing answers or ask your own question to get the quick design help you need.

Linked content is provided "AS IS" by the respective contributors. They do not constitute TI specifications and do not necessarily reflect TI's views; see TI's [Terms of Use](#).

8.4 Trademarks

TI E2E™ is a trademark of Texas Instruments.

All trademarks are the property of their respective owners.

8.5 Electrostatic Discharge Caution



This integrated circuit can be damaged by ESD. Texas Instruments recommends that all integrated circuits be handled with appropriate precautions. Failure to observe proper handling and installation procedures can cause damage.

ESD damage can range from subtle performance degradation to complete device failure. Precision integrated circuits may be more susceptible to damage because very small parametric changes could cause the device not to meet its published specifications.

8.6 Glossary

[TI Glossary](#) This glossary lists and explains terms, acronyms, and definitions.

9 Mechanical, Packaging, and Orderable Information

The following pages include mechanical, packaging, and orderable information. This information is the most current data available for the designated devices. This data is subject to change without notice and revision of this document. For browser-based versions of this data sheet, refer to the left-hand navigation.

PACKAGING INFORMATION

Orderable Device	Status (1)	Package Type	Package Drawing	Pins	Package Qty	Eco Plan (2)	Lead finish/ Ball material (6)	MSL Peak Temp (3)	Op Temp (°C)	Device Marking (4/5)	Samples
SN75179BDR	ACTIVE	SOIC	D	8	2500	RoHS & Green	NIPDAU	Level-1-260C-UNLIM	0 to 70	75179B	Samples
SN75179BDRG4	ACTIVE	SOIC	D	8	2500	RoHS & Green	NIPDAU	Level-1-260C-UNLIM	0 to 70	75179B	Samples
SN75179BP	ACTIVE	PDIP	P	8	50	RoHS & Green	NIPDAU	N / A for Pkg Type	0 to 70	SN75179BP	Samples
SN75179BPE4	ACTIVE	PDIP	P	8	50	RoHS & Green	NIPDAU	N / A for Pkg Type	0 to 70	SN75179BP	Samples
SN75179BPSR	ACTIVE	SO	PS	8	2000	RoHS & Green	NIPDAU	Level-1-260C-UNLIM	0 to 70	A179B	Samples

(1) The marketing status values are defined as follows:

ACTIVE: Product device recommended for new designs.

LIFEBUY: TI has announced that the device will be discontinued, and a lifetime-buy period is in effect.

NRND: Not recommended for new designs. Device is in production to support existing customers, but TI does not recommend using this part in a new design.

PREVIEW: Device has been announced but is not in production. Samples may or may not be available.

OBSELETE: TI has discontinued the production of the device.

(2) **RoHS:** TI defines "RoHS" to mean semiconductor products that are compliant with the current EU RoHS requirements for all 10 RoHS substances, including the requirement that RoHS substance do not exceed 0.1% by weight in homogeneous materials. Where designed to be soldered at high temperatures, "RoHS" products are suitable for use in specified lead-free processes. TI may reference these types of products as "Pb-Free".

RoHS Exempt: TI defines "RoHS Exempt" to mean products that contain lead but are compliant with EU RoHS pursuant to a specific EU RoHS exemption.

Green: TI defines "Green" to mean the content of Chlorine (Cl) and Bromine (Br) based flame retardants meet JS709B low halogen requirements of <=1000ppm threshold. Antimony trioxide based flame retardants must also meet the <=1000ppm threshold requirement.

(3) MSL, Peak Temp. - The Moisture Sensitivity Level rating according to the JEDEC industry standard classifications, and peak solder temperature.

(4) There may be additional marking, which relates to the logo, the lot trace code information, or the environmental category on the device.

(5) Multiple Device Markings will be inside parentheses. Only one Device Marking contained in parentheses and separated by a "~" will appear on a device. If a line is indented then it is a continuation of the previous line and the two combined represent the entire Device Marking for that device.

(6) Lead finish/Ball material - Orderable Devices may have multiple material finish options. Finish options are separated by a vertical ruled line. Lead finish/Ball material values may wrap to two lines if the finish value exceeds the maximum column width.

Important Information and Disclaimer: The information provided on this page represents TI's knowledge and belief as of the date that it is provided. TI bases its knowledge and belief on information provided by third parties, and makes no representation or warranty as to the accuracy of such information. Efforts are underway to better integrate information from third parties. TI has taken and continues to take reasonable steps to provide representative and accurate information but may not have conducted destructive testing or chemical analysis on incoming materials and chemicals. TI and TI suppliers consider certain information to be proprietary, and thus CAS numbers and other limited information may not be available for release.

In no event shall TI's liability arising out of such information exceed the total purchase price of the TI part(s) at issue in this document sold by TI to Customer on an annual basis.

TAPE AND REEL INFORMATION



QUADRANT ASSIGNMENTS FOR PIN 1 ORIENTATION IN TAPE



*All dimensions are nominal

Device	Package Type	Package Drawing	Pins	SPQ	Reel Diameter (mm)	Reel Width W1 (mm)	A0 (mm)	B0 (mm)	K0 (mm)	P1 (mm)	W (mm)	Pin1 Quadrant
SN75179BDR	SOIC	D	8	2500	330.0	12.4	6.4	5.2	2.1	8.0	12.0	Q1
SN75179BPSR	SO	PS	8	2000	330.0	16.4	8.35	6.6	2.4	12.0	16.0	Q1

TAPE AND REEL BOX DIMENSIONS

*All dimensions are nominal

Device	Package Type	Package Drawing	Pins	SPQ	Length (mm)	Width (mm)	Height (mm)
SN75179BDR	SOIC	D	8	2500	356.0	356.0	35.0
SN75179BPSR	SO	PS	8	2000	356.0	356.0	35.0

TUBE

*All dimensions are nominal

Device	Package Name	Package Type	Pins	SPQ	L (mm)	W (mm)	T (μm)	B (mm)
SN75179BP	P	PDIP	8	50	506	13.97	11230	4.32
SN75179BPE4	P	PDIP	8	50	506	13.97	11230	4.32



D0008A

PACKAGE OUTLINE

SOIC - 1.75 mm max height

SMALL OUTLINE INTEGRATED CIRCUIT



4214825/C 02/2019

NOTES:

- Linear dimensions are in inches [millimeters]. Dimensions in parenthesis are for reference only. Controlling dimensions are in inches. Dimensioning and tolerancing per ASME Y14.5M.
- This drawing is subject to change without notice.
- This dimension does not include mold flash, protrusions, or gate burrs. Mold flash, protrusions, or gate burrs shall not exceed .006 [0.15] per side.
- This dimension does not include interlead flash.
- Reference JEDEC registration MS-012, variation AA.

EXAMPLE BOARD LAYOUT

D0008A

SOIC - 1.75 mm max height

SMALL OUTLINE INTEGRATED CIRCUIT

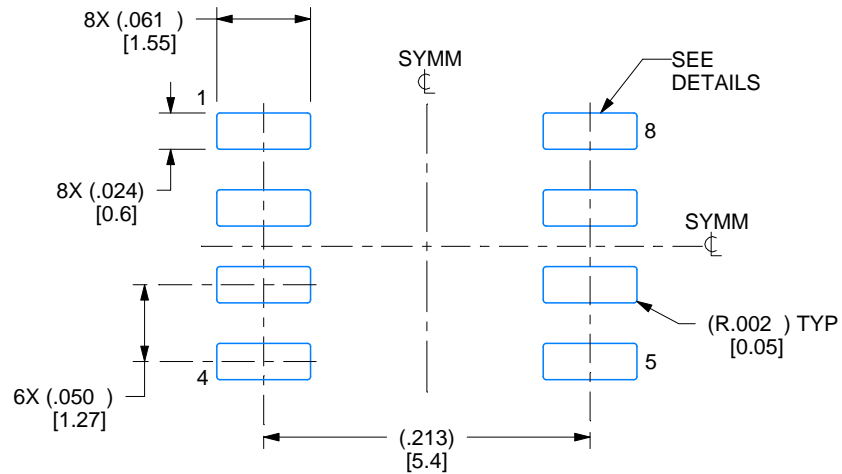

LAND PATTERN EXAMPLE
EXPOSED METAL SHOWN
SCALE:8X

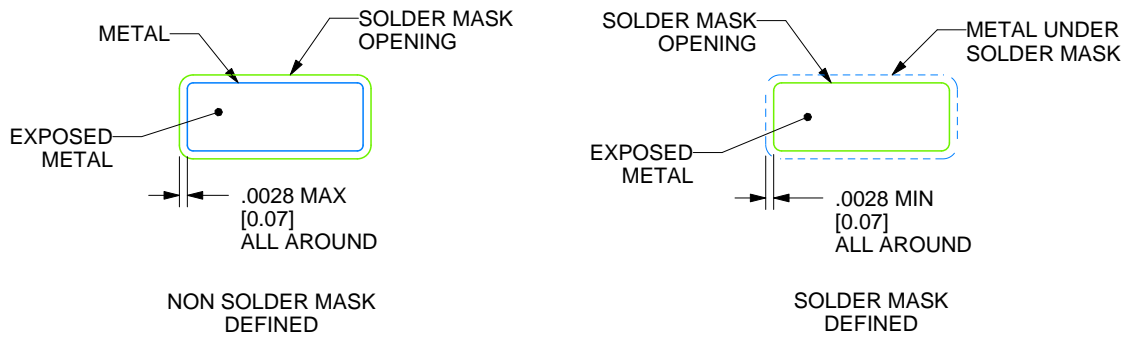

SOLDER MASK DETAILS

4214825/C 02/2019

NOTES: (continued)

6. Publication IPC-7351 may have alternate designs.

7. Solder mask tolerances between and around signal pads can vary based on board fabrication site.

EXAMPLE STENCIL DESIGN

D0008A

SOIC - 1.75 mm max height

SMALL OUTLINE INTEGRATED CIRCUIT



SOLDER PASTE EXAMPLE
BASED ON .005 INCH [0.125 MM] THICK STENCIL
SCALE:8X

4214825/C 02/2019

NOTES: (continued)

8. Laser cutting apertures with trapezoidal walls and rounded corners may offer better paste release. IPC-7525 may have alternate design recommendations.
9. Board assembly site may have different recommendations for stencil design.

MECHANICAL DATA

PS (R-PDSO-G8)

PLASTIC SMALL-OUTLINE PACKAGE

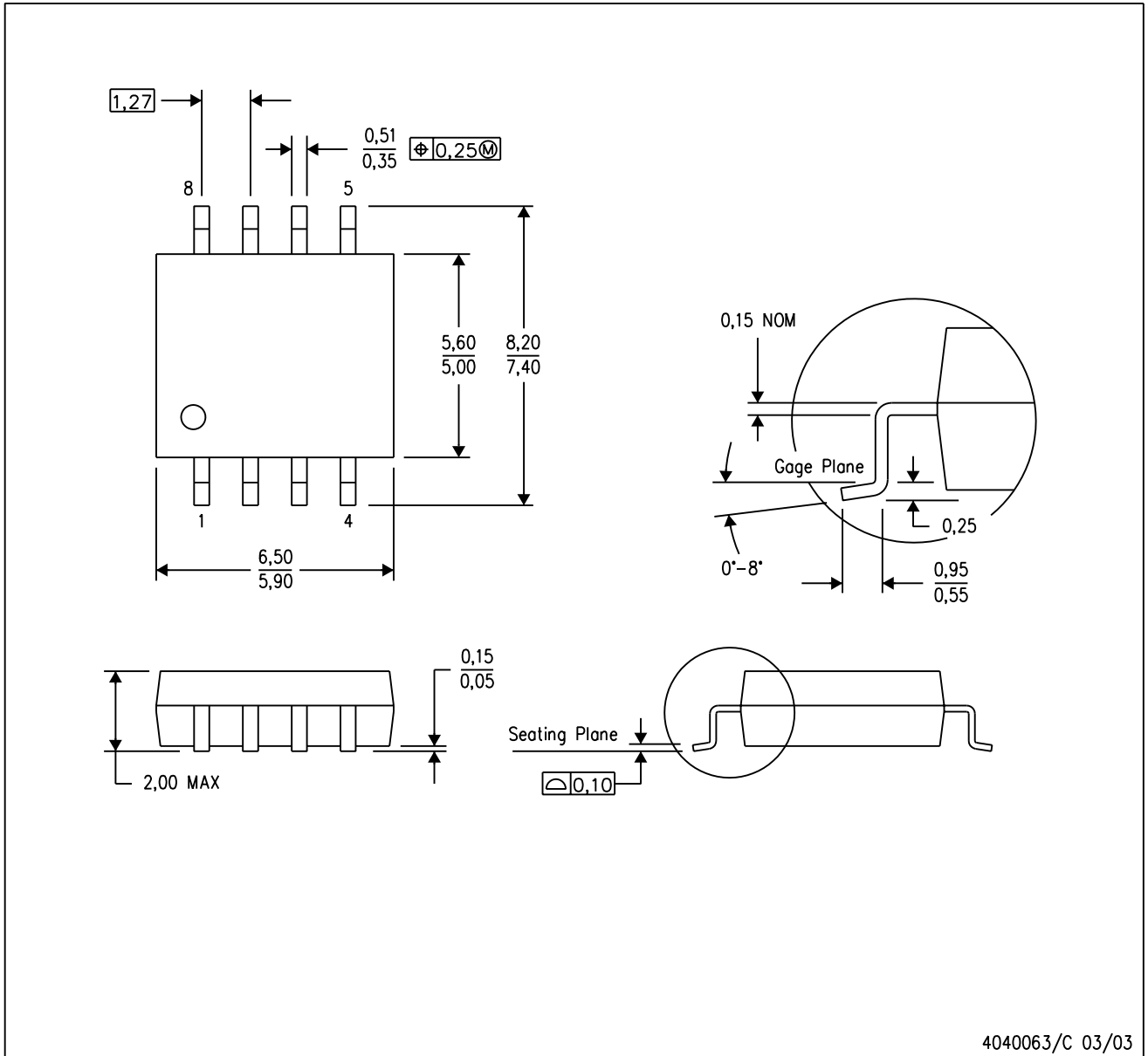

- NOTES:
- A. All linear dimensions are in millimeters.
 - B. This drawing is subject to change without notice.
 - C. Body dimensions do not include mold flash or protrusion, not to exceed 0,15.

P (R-PDIP-T8)

PLASTIC DUAL-IN-LINE PACKAGE

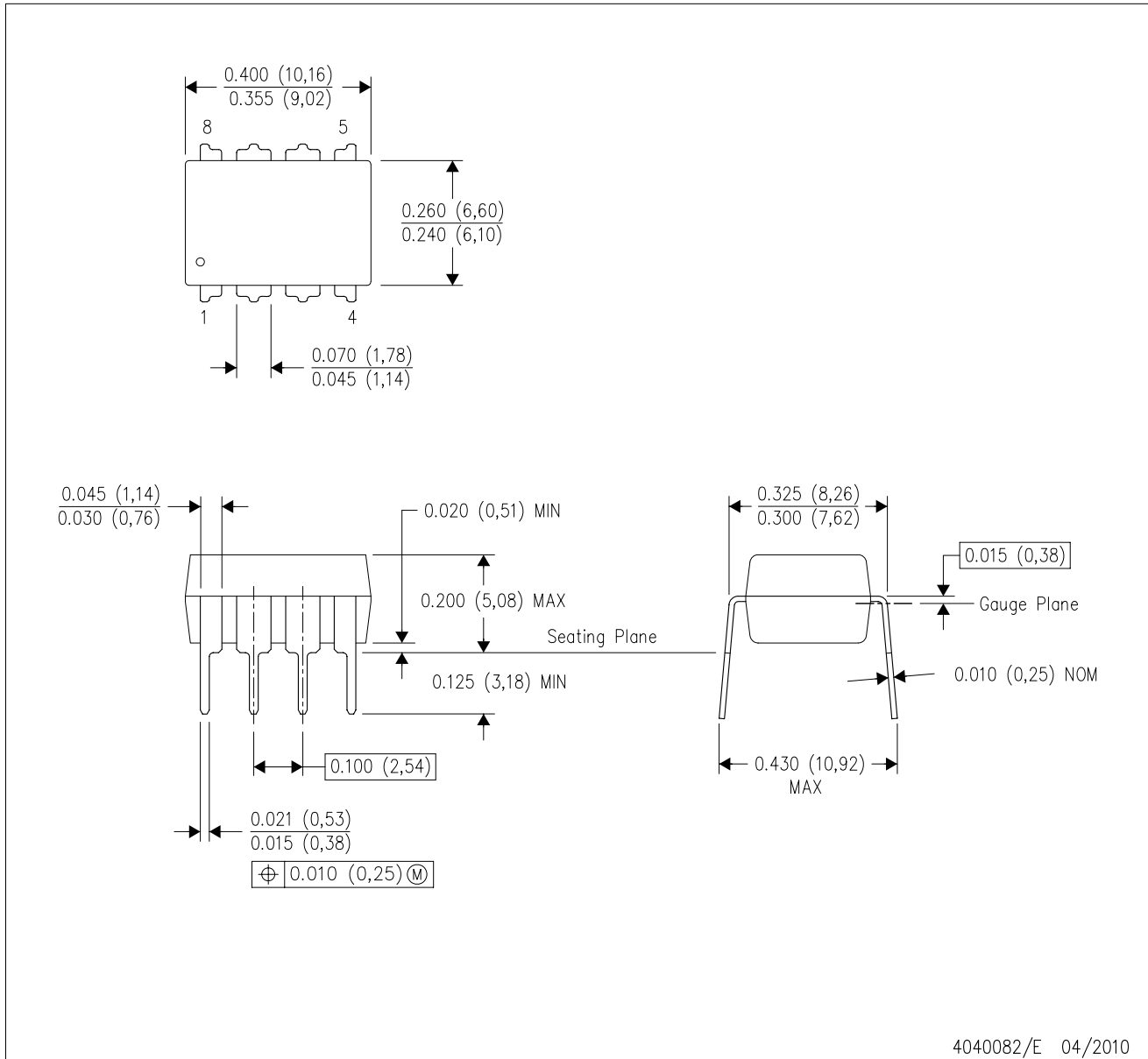

- NOTES:
- A. All linear dimensions are in inches (millimeters).
 - B. This drawing is subject to change without notice.
 - C. Falls within JEDEC MS-001 variation BA.

IMPORTANT NOTICE AND DISCLAIMER

TI PROVIDES TECHNICAL AND RELIABILITY DATA (INCLUDING DATA SHEETS), DESIGN RESOURCES (INCLUDING REFERENCE DESIGNS), APPLICATION OR OTHER DESIGN ADVICE, WEB TOOLS, SAFETY INFORMATION, AND OTHER RESOURCES "AS IS" AND WITH ALL FAULTS, AND DISCLAIMS ALL WARRANTIES, EXPRESS AND IMPLIED, INCLUDING WITHOUT LIMITATION ANY IMPLIED WARRANTIES OF MERCHANTABILITY, FITNESS FOR A PARTICULAR PURPOSE OR NON-INFRINGEMENT OF THIRD PARTY INTELLECTUAL PROPERTY RIGHTS.

These resources are intended for skilled developers designing with TI products. You are solely responsible for (1) selecting the appropriate TI products for your application, (2) designing, validating and testing your application, and (3) ensuring your application meets applicable standards, and any other safety, security, regulatory or other requirements.

These resources are subject to change without notice. TI grants you permission to use these resources only for development of an application that uses the TI products described in the resource. Other reproduction and display of these resources is prohibited. No license is granted to any other TI intellectual property right or to any third party intellectual property right. TI disclaims responsibility for, and you will fully indemnify TI and its representatives against, any claims, damages, costs, losses, and liabilities arising out of your use of these resources.

TI's products are provided subject to [TI's Terms of Sale](#) or other applicable terms available either on [ti.com](https://www.ti.com) or provided in conjunction with such TI products. TI's provision of these resources does not expand or otherwise alter TI's applicable warranties or warranty disclaimers for TI products.

TI objects to and rejects any additional or different terms you may have proposed.

Mailing Address: Texas Instruments, Post Office Box 655303, Dallas, Texas 75265
Copyright © 2023, Texas Instruments Incorporated

Looking for pricing, stock, or lifecycle information?

Click below to explore more details on WIN SOURCE:

 [View SN75179BDRG4 on WIN SOURCE](#)

 [Texas Instruments](#) Information

Optimize Your Supply Chain with WIN SOURCE Solutions

-  Global Sourcing Solution
-  Obsolete Management
-  Cost Control Management
-  Shortage Management
-  Alternative Solution
-  Excess Inventory Management