



## 3-V to 5.5-V Single-Channel RS-232 Compatible Line Driver and Receiver

### 1 Features

- Operate with 3-V to 5.5-V  $V_{CC}$  supply
- Operate up to 1 Mbit/s
- Low standby current : 1  $\mu$ A typical
- External capacitors : 4 x 0.1  $\mu$ F
- Accepts 5-V logic input with 3.3-V supply
- RS-232 bus-pin ESD protection exceeds  $\pm 15$  kV using human-body model (HBM)
- Auto-powerdown feature automatically disables drivers for power savings

### 2 Applications

- [Industrial PCs](#)
- [Wired networking](#)
- [Data center and enterprise computing](#)
- [Battery-powered systems](#)
- [PDAs](#)
- [Notebooks](#)
- [Laptops](#)
- [Palmtop PCs](#)
- [Hand-held equipment](#)

### 3 Description

The SN65C3221 and SN75C3221 consist of one line driver, one line receiver, and a dual charge-pump circuit with  $\pm 15$ -kV ESD protection pin to pin (serial-port connection pins, including GND). These devices provide the electrical interface between an asynchronous communication controller and the serial-port connector. The charge pump and four small external capacitors allow operation from a single 3-V to 5.5-V supply. These devices operate at data signaling rates up to 1 Mbit/s and a driver output slew rate of 24 V/ $\mu$ s to 150 V/ $\mu$ s.

Flexible control options for power management are available when the serial port is inactive. The auto-powerdown feature functions when FORCEON is low and FORCEOFF is high. During this mode of operation, if the devices do not sense a valid RS-232 signal on the receiver input, the driver output is disabled. If FORCEOFF is set low and  $\overline{EN}$  is high, both the driver and receiver are shut off, and the supply current is reduced to 1  $\mu$ A. Disconnecting the serial port or turning off the peripheral drivers causes the auto-powerdown condition to occur. Auto-powerdown can be disabled when FORCEON and FORCEOFF are high. With auto-powerdown enabled, the device is activated automatically when a valid signal is applied to the receiver input. The  $\overline{INVALID}$  output notifies the user if an RS-232 signal is present at the receiver input.  $\overline{INVALID}$  is high (valid data) if the receiver input voltage is greater than 2.7 V or less than  $-2.7$  V, or has been between  $-0.3$  V and 0.3 V for less than 30  $\mu$ s.  $\overline{INVALID}$  is low (invalid data) if the receiver input voltage is between  $-0.3$  V and 0.3 V for more than 30  $\mu$ s. Refer to [Figure 7-5](#) for receiver input levels.

#### Device Information

PART NUMBER	PACKAGE <sup>(1)</sup>	BODY SIZE (NOM)
SNx5C3221	SSOP (DB) 16	6.20 mm x 5.30 mm
	TSSOP (PW) 16	10.3 mm x 7.50 mm

- (1) For all available packages, see the orderable addendum at the end of the data sheet.

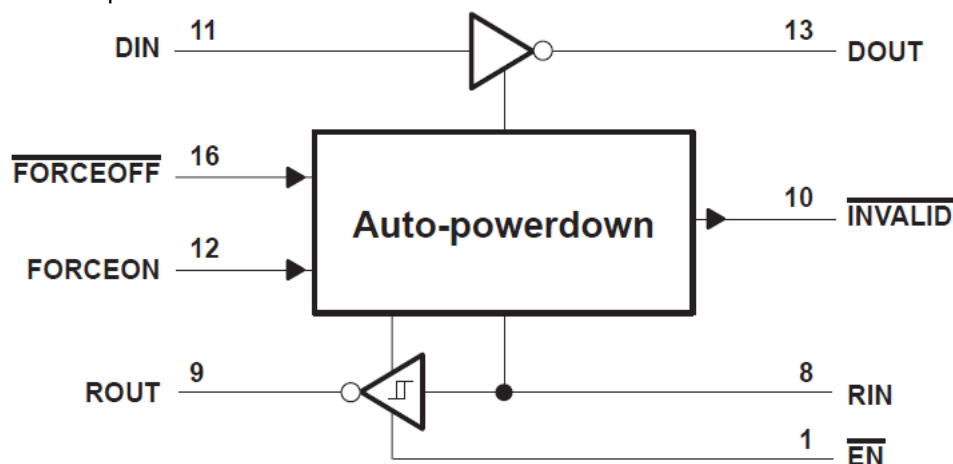

Logic Diagram (Positive Logic)



## Table of Contents

<b>1 Features</b> .....	1	6.10 Switching Characteristics - Auto-Powerdown.....	7
<b>2 Applications</b> .....	1	<b>7 Parameter Measurement Information</b> .....	8
<b>3 Description</b> .....	1	<b>8 Detailed Description</b> .....	11
<b>4 Revision History</b> .....	2	8.1 Device Functional Modes.....	11
<b>5 Pin Configuration and Functions</b> .....	3	<b>9 Application and Implementation</b> .....	12
<b>6 Specifications</b> .....	4	9.1 Application Information.....	12
6.1 Absolute Maximum Ratings.....	4	<b>10 Device and Documentation Support</b> .....	13
6.2 ESD Ratings.....	4	10.1 Receiving Notification of Documentation Updates..	13
6.3 Recommended Operating Conditions <sup>(1)</sup> .....	4	10.2 Support Resources.....	13
6.4 Electrical Characteristics.....	5	10.3 Trademarks.....	13
6.5 Electrical Characteristics - Driver.....	6	10.4 Electrostatic Discharge Caution.....	13
6.6 Switching Characteristics - Driver.....	6	10.5 Glossary.....	13
6.7 Electrical Characteristics - Receiver.....	6	<b>11 Mechanical, Packaging, and Orderable Information</b> .....	13
6.8 Switching Characteristics - Receiver.....	7		
6.9 Electrical Characteristics - Auto-Powerdown.....	7		

## 4 Revision History

NOTE: Page numbers for previous revisions may differ from page numbers in the current version.

Changes from Revision E (October 2004) to Revision F (July 2021)	Page
• Changed the <i>Applications</i> list.....	1
• Deleted the Oderaing Information table.....	1
• Added the <i>Device Information</i> table.....	1
• Removed the thermal parameters from <i>Absolute Maximum Ratings</i> table and moved them to <i>Thermal Information</i> table.....	4
• Added <i>ESD Ratings</i> table. Moved the driver and receiver ESD specifications to this table.....	4
• Changed the thermal parameters for PW package of SN65C3221 and DB package of SN75C3221. Added additional thermal parameters for both the packages in the <i>Thermal Information</i> table.....	5
• Added the <i>Detailed Description</i> section.....	11

## 5 Pin Configuration and Functions

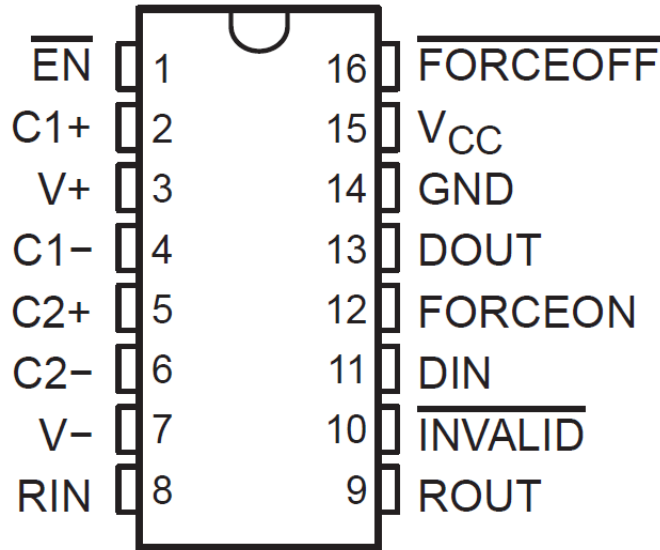

**Figure 5-1. DB or PW Package  
Top View**

**Table 5-1. Pin Functions**

PIN		I/O	DESCRIPTION
NAME	NO.		
C1+	2	—	Positive terminals of the voltage-doubler charge-pump capacitors
C2+	5		
C1-	4		
C2-	6		
DIN	11	I	Driver input
DOUT	13	O	RS-232 driver output
EN	1	I	Low input enables receiver ROUT output. High input sets ROUT to high impedance.
FORCEOFF	16	I	Automatic power-down control input
FORCEON	12	I	Automatic power-down control input
GND	14	—	Ground
INVALID	10	O	Invalid output pin. Output low when all RIN inputs are unpowered.
RIN	8	I	RS-232 receiver input
ROUT	9	O	Receiver output
V <sub>CC</sub>	15	—	3-V to 5.5-V supply voltage
V+	3	O	5.5-V supply generated by the charge pump
V-	7	O	-5.5-V supply generated by the charge pump

## 6 Specifications

### 6.1 Absolute Maximum Ratings

over operating free-air temperature range (unless otherwise noted)<sup>(1)</sup>

		MIN	MAX	UNIT	
V <sub>CC</sub>	Supply voltage range	-0.3	6	V	
V+	Positive output supply voltage range <sup>(2)</sup>	-0.3	7	V	
V-	Negative output supply voltage range <sup>(2)</sup>	-7	0.3	V	
V+ - V-	Supply voltage difference <sup>(2)</sup>		13	V	
V <sub>I</sub>	Input voltage range	Driver (FORCEOFF, FORCEON, $\overline{\text{EN}}$ )	-0.3	6	V
		Receiver	-25	25	
V <sub>O</sub>	Output voltage range	Driver	-13.2	13.2	V
		Receiver (INVALID)	-0.3	V <sub>CC</sub> + 0.3	
T <sub>J</sub>	Operating virtual junction temperature		150	°C	
T <sub>stg</sub>	Storage temperature	-65	150	°C	

- (1) Stresses beyond those listed under *absolute maximum ratings* may cause permanent damage to the device. These are stress ratings only and functional operation of the device at these or any other conditions beyond those indicated under [Section 6.3](#) is not implied. Exposure to absolute-maximum-rated conditions for extended periods may affect device reliability.
- (2) All voltage values are with respect to network ground terminal GND.

### 6.2 ESD Ratings

			VALUE	UNIT	
V <sub>(ESD)</sub>	Electrostatic discharge	Human-body model (HBM), per ANSI/ESDA/JEDEC JS-001 <sup>1</sup>	RIN and DOUT Pins	±15000	V
			All other pins	±3000	
		Charged-device model (CDM), per JEDEC specification JESD22-C101 <sup>2</sup>	All pins	±1500	

### 6.3 Recommended Operating Conditions<sup>(1)</sup>

(see [Figure 9-1](#))

		MIN	NOM	MAX	UNIT	
	Supply voltage	V <sub>CC</sub> = 3.3 V	3	3.3	3.6	V
		V <sub>CC</sub> = 5 V	4.5	5	5.5	
V <sub>IH</sub>	Driver and control high-level input voltage	DIN, FORCEOFF, FORCEON, $\overline{\text{EN}}$	V <sub>CC</sub> = 3.3 V	2		V
			V <sub>CC</sub> = 5 V	2.4		
V <sub>IL</sub>	Driver and control low-level input voltage	DIN, FORCEOFF, FORCEON, $\overline{\text{EN}}$		0.8	V	
V <sub>I</sub>	Driver and control input voltage	DIN, FORCEOFF, FORCEON		0	5.5	V
V <sub>I</sub>	Receiver input voltage	-25		25	V	
T <sub>A</sub>	Operating free-air temperature	SN65C3221	-40	85	°C	
		SN75C3221	0	70		

- (1) Test conditions are C1–C4 = 0.1 μF at V<sub>CC</sub> = 3.3 V ± 0.3 V; C1 = 0.047 μF, C2–C4 = 0.33 μF at V<sub>CC</sub> = 5 V ± 0.5 V.

### 6.3.1 Thermal Information

THERMAL METRIC <sup>1</sup>		SN65C3221		SN75C3221		UNIT
		DB (SSOP)	PW (TSSOP)	DB (SSOP)	PW (TSSOP)	
		16 PINS	16 PINS	16 PINS	16 PINS	
$R_{\theta JA}$	Junction-to-ambient thermal resistance	82.0	110.9	105.8	108.0	°C/W
$R_{\theta JC(top)}$	Junction-to-case (top) thermal resistance	45.7	41.7	51.9	41.1	°C/W
$R_{\theta JB}$	Junction-to-board thermal resistance	44.4	57.2	57.6	51.4	°C/W
$\Psi_{JT}$	Junction-to-top characterization parameter	11.0	4.2	14.1	3.9	°C/W
$\Psi_{JB}$	Junction-to-board characterization parameter	43.8	56.6	56.8	50.9	°C/W

### 6.4 Electrical Characteristics

over recommended operating free-air temperature ranges of supply voltage and operating free-air temperature (unless otherwise noted)<sup>(2)</sup> (see Figure 9-1)

PARAMETER			TEST CONDITIONS	MIN	TYP <sup>(1)</sup>	MAX	UNIT
$I_I$	Input leakage current	FORCEOFF, FORCEON, EN			±0.01	±1	μA
$I_{CC}$	Supply current ( $T_A = 25^\circ\text{C}$ )	Auto-powerdown disabled	No load, FORCEOFF and FORCEON at $V_{CC}$		0.3	1	mA
		Powered off	No load, FORCEOFF at GND		1	10	
		Auto-powerdown enabled	No load, FORCEOFF at $V_{CC}$ , FORCEON at GND, All RIN are open or grounded		1	10	μA

(1) All typical values are at  $V_{CC} = 3.3\text{ V}$  or  $V_{CC} = 5\text{ V}$ , and  $T_A = 25^\circ\text{C}$ .

(2) Test conditions are C1–C4 = 0.1 μF at  $V_{CC} = 3.3\text{ V} \pm 0.3\text{ V}$ ; C1 = 0.047 μF, C2–C4 = 0.33 μF at  $V_{CC} = 5\text{ V} \pm 0.5\text{ V}$ .

## 6.5 Electrical Characteristics - Driver

over recommended ranges of supply voltage and operating free-air temperature range (unless otherwise noted)<sup>(3)</sup> (see Figure 9-1)

PARAMETER		TEST CONDITIONS		MIN	TYP <sup>(1)</sup>	MAX	UNIT
V <sub>OH</sub>	High-level output voltage	DOUT at R <sub>L</sub> = 3 kΩ to GND,	DIN = GND	5	5.4		V
V <sub>OL</sub>	Low-level output voltage	DOUT at R <sub>L</sub> = 3 kΩ to GND,	DIN = V <sub>CC</sub>	-5	-5.4		V
I <sub>IH</sub>	High-level input current	V <sub>I</sub> = V <sub>CC</sub>			±0.01	±1	μA
I <sub>IL</sub>	Low-level input current	V <sub>I</sub> at GND			±0.01	±1	μA
I <sub>OS</sub>	Short-circuit output current <sup>(2)</sup>	V <sub>CC</sub> = 3.6 V,	V <sub>O</sub> = 0 V		±35	±60	mA
		V <sub>CC</sub> = 5.5 V,	V <sub>O</sub> = 0 V		±35	±90	
r <sub>o</sub>	Output resistance	V <sub>CC</sub> , V+, and V- = 0 V,	V <sub>O</sub> = ±2 V	300	10M		Ω
I <sub>off</sub>	Output leakage current	FORCEOFF = GND	V <sub>O</sub> = ±12 V, V <sub>CC</sub> = 3 V to 3.6 V			±25	μA
			V <sub>O</sub> = ±10 V, V <sub>CC</sub> = 4.5 V to 5.5 V			±25	

(1) All typical values are at V<sub>CC</sub> = 3.3 V or V<sub>CC</sub> = 5 V, and T<sub>A</sub> = 25°C.

(2) Short-circuit durations should be controlled to prevent exceeding the device absolute power-dissipation ratings, and not more than one output should be shorted at a time.

(3) Test conditions are C1–C4 = 0.1 μF at V<sub>CC</sub> = 3.3 V ± 0.3 V; C1 = 0.047 μF, C2–C4 = 0.33 μF at V<sub>CC</sub> = 5 V ± 0.5 V.

## 6.6 Switching Characteristics - Driver

over recommended ranges of supply voltage and operating free-air temperature (unless otherwise noted)<sup>(3)</sup> (see Figure 9-1)

PARAMETER		TEST CONDITIONS		MIN	TYP <sup>(1)</sup>	MAX	UNIT
Maximum data rate (see Figure 7-1)	R <sub>L</sub> = 3 kΩ	C <sub>L</sub> = 1000 pF		250			kbit/s
		C <sub>L</sub> = 250 pF,	V <sub>CC</sub> = 3 V to 4.5 V	1000			
		C <sub>L</sub> = 1000 pF,	V <sub>CC</sub> = 4.5 V to 5.5 V	1000			
t <sub>sk(p)</sub>	Pulse skew <sup>(2)</sup>	C <sub>L</sub> = 150 pF to 2500 pF	R <sub>L</sub> = 3 kΩ to 7 kΩ, See Figure 7-2	100			ns
SR(tr)	Slew rate, transition region (see Figure 7-1)	V <sub>CC</sub> = 3.3 V, R <sub>L</sub> = 3 kΩ to 7 kΩ	C <sub>L</sub> = 150 pF to 1000 pF	18		150	V/μs

(1) All typical values are at V<sub>CC</sub> = 3.3 V or V<sub>CC</sub> = 5 V, and T<sub>A</sub> = 25°C.

(2) Pulse skew is defined as |t<sub>PLH</sub> - t<sub>PHL</sub>| of each channel of the same device.

(3) Test conditions are C1–C4 = 0.1 μF at V<sub>CC</sub> = 3.3 V ± 0.3 V; C1 = 0.047 μF, C2–C4 = 0.33 μF at V<sub>CC</sub> = 5 V ± 0.5 V.

## 6.7 Electrical Characteristics - Receiver

over recommended ranges of supply voltage and operating free-air temperature (unless otherwise noted)<sup>(2)</sup> (see Figure 9-1)

PARAMETER		TEST CONDITIONS	MIN	TYP <sup>(1)</sup>	MAX	UNIT
V <sub>OH</sub>	High-level output voltage	I <sub>OH</sub> = -1 mA	V <sub>CC</sub> - 0.6 V	V <sub>CC</sub> - 0.1 V		V
V <sub>OL</sub>	Low-level output voltage	I <sub>OL</sub> = 1.6 mA			0.4	V
V <sub>IT+</sub>	Positive-going input threshold voltage	V <sub>CC</sub> = 3.3 V		1.6	2.4	V
		V <sub>CC</sub> = 5 V		1.9	2.4	
V <sub>IT-</sub>	Negative-going input threshold voltage	V <sub>CC</sub> = 3.3 V	0.6	1.1		V
		V <sub>CC</sub> = 5 V	0.8	1.4		
V <sub>hys</sub>	Input hysteresis (V <sub>IT+</sub> - V <sub>IT-</sub> )			0.5		V
I <sub>off</sub>	Output leakage current	FORCEOFF = 0 V		±0.05	±10	μA
r <sub>i</sub>	Input resistance	V <sub>I</sub> = ±3 V to ±25 V	3	5	7	kΩ

(1) All typical values are at V<sub>CC</sub> = 3.3 V or V<sub>CC</sub> = 5 V, and T<sub>A</sub> = 25°C.

(2) Test conditions are C1–C4 = 0.1 μF at V<sub>CC</sub> = 3.3 V ± 0.3 V; C1 = 0.047 μF, C2–C4 = 0.33 μF at V<sub>CC</sub> = 5 V ± 0.5 V.

## 6.8 Switching Characteristics - Receiver

over recommended ranges of supply voltage and operating free-air temperature range (unless otherwise noted)<sup>(3)</sup>

PARAMETER		TEST CONDITIONS		MIN	TYP <sup>(1)</sup>	MAX	UNIT
t <sub>PLH</sub>	Propagation delay time, low- to high-level output	C <sub>L</sub> = 150 pF,	See Figure 7-3		150		ns
t <sub>PHL</sub>	Propagation delay time, high- to low-level output	C <sub>L</sub> = 150 pF,	See Figure 7-3		150		ns
t <sub>en</sub>	Output enable time	C <sub>L</sub> = 150 pF, R <sub>L</sub> = 3 kΩ,	See Figure 7-4		200		ns
t <sub>dis</sub>	Output disable time	C <sub>L</sub> = 150 pF, R <sub>L</sub> = 3 kΩ,	See Figure 7-4		200		ns
t <sub>sk(p)</sub>	Pulse skew <sup>(2)</sup>	See Figure 7-3			50		ns

(1) All typical values are at V<sub>CC</sub> = 3.3 V or V<sub>CC</sub> = 5 V, and T<sub>A</sub> = 25°C.

(2) Pulse skew is defined as |t<sub>PLH</sub> - t<sub>PHL</sub>| of each channel of the same device.

(3) Test conditions are C1-C4 = 0.1 μF at V<sub>CC</sub> = 3.3 V ± 0.3 V; C1 = 0.047 μF, C2-C4 = 0.33 μF at V<sub>CC</sub> = 5 V ± 0.5 V.

## 6.9 Electrical Characteristics - Auto-Powerdown

over recommended ranges of supply voltage and operating free-air temperature range (unless otherwise noted) (see Figure 7-5)

PARAMETER		TEST CONDITIONS		MIN	MAX	UNIT
V <sub>T+(valid)</sub>	Receiver input threshold for $\overline{\text{INVALID}}$ high-level output voltage	FORCEON = GND,	$\overline{\text{FORCEOFF}} = V_{CC}$		2.7	V
V <sub>T-(valid)</sub>	Receiver input threshold for $\overline{\text{INVALID}}$ high-level output voltage	FORCEON = GND,	$\overline{\text{FORCEOFF}} = V_{CC}$	-2.7		V
V <sub>T(invalid)</sub>	Receiver input threshold for $\overline{\text{INVALID}}$ low-level output voltage	FORCEON = GND,	$\overline{\text{FORCEOFF}} = V_{CC}$	-0.3	0.3	V
V <sub>OH</sub>	$\overline{\text{INVALID}}$ high-level output voltage	I <sub>OH</sub> = -1 mA, FORCEON = GND, $\overline{\text{FORCEOFF}} = V_{CC}$		V <sub>CC</sub> -0.6		V
V <sub>OL</sub>	$\overline{\text{INVALID}}$ low-level output voltage	I <sub>OL</sub> = 1.6 mA, FORCEON = GND, $\overline{\text{FORCEOFF}} = V_{CC}$		0.4		V

## 6.10 Switching Characteristics - Auto-Powerdown

over operating free-air temperature range (unless otherwise noted) (see Figure 7-5)

PARAMETER		MIN	TYP <sup>(1)</sup>	MAX	UNIT
t <sub>valid</sub>	Propagation delay time, low- to high-level output		1		μs
t <sub>invalid</sub>	Propagation delay time, high- to low-level output		30		μs
t <sub>en</sub>	Supply enable time		100		μs

(1) All typical values are at V<sub>CC</sub> = 3.3 V or V<sub>CC</sub> = 5 V, and T<sub>A</sub> = 25°C.

## 7 Parameter Measurement Information

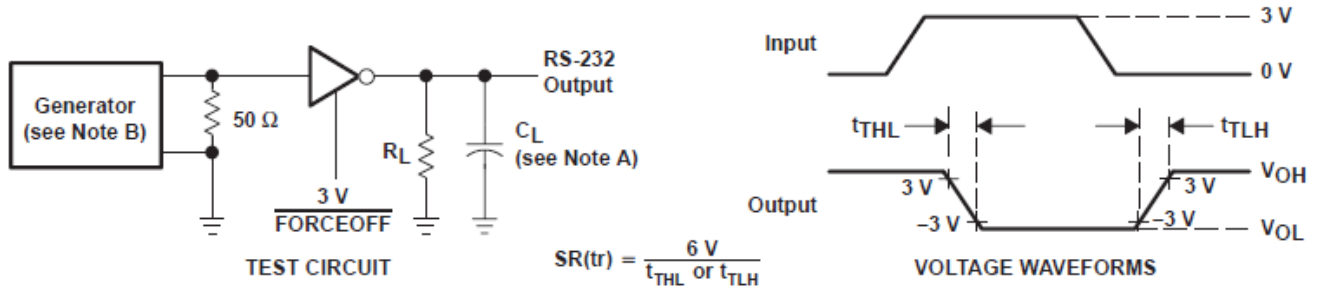

NOTES: A.  $C_L$  includes probe and jig capacitance.

B. The pulse generator has the following characteristics: PRR = 250 kbit/s,  $Z_O = 50\ \Omega$ , 50% duty cycle,  $t_r \leq 10\text{ ns}$ ,  $t_f \leq 10\text{ ns}$ .

**Figure 7-1. Driver Slew Rate**

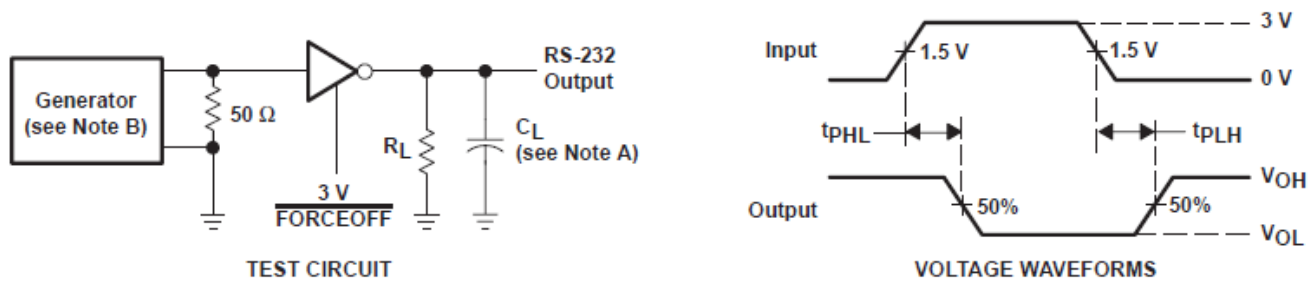

NOTES: A.  $C_L$  includes probe and jig capacitance.

B. The pulse generator has the following characteristics: PRR = 250 kbit/s,  $Z_O = 50\ \Omega$ , 50% duty cycle,  $t_r \leq 10\text{ ns}$ ,  $t_f \leq 10\text{ ns}$ .

**Figure 7-2. Driver Pulse Skew**

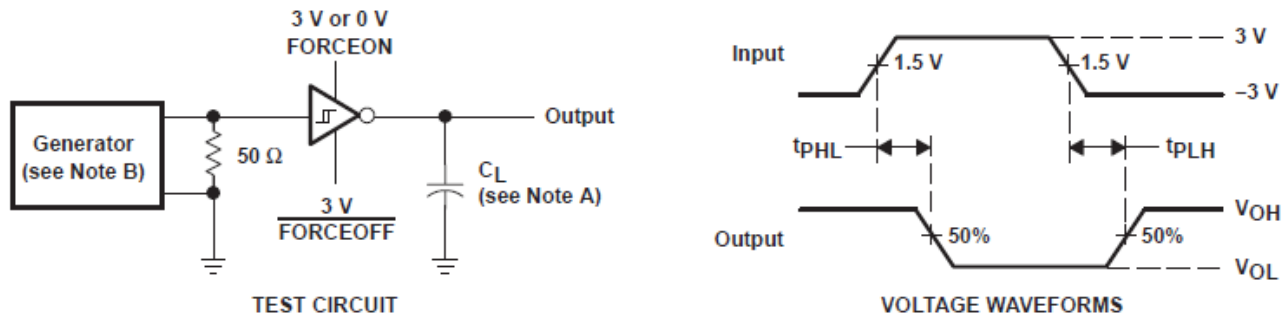

NOTES: A.  $C_L$  includes probe and jig capacitance.

B. The pulse generator has the following characteristics:  $Z_O = 50\ \Omega$ , 50% duty cycle,  $t_r \leq 10\text{ ns}$ ,  $t_f \leq 10\text{ ns}$ .

**Figure 7-3. Receiver Propagation Delay Times**

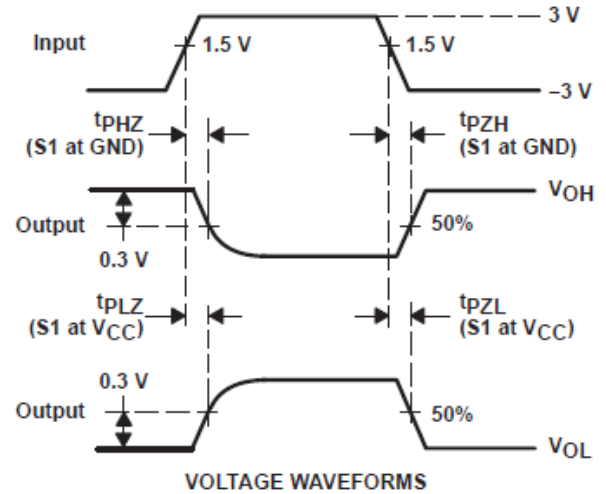
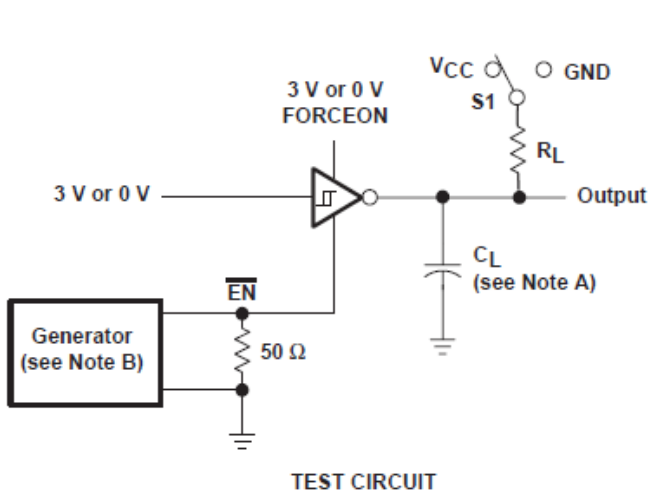

- NOTES:
- A.  $C_L$  includes probe and jig capacitance.
  - B. The pulse generator has the following characteristics:  $Z_O = 50\ \Omega$ , 50% duty cycle,  $t_r \leq 10\ \text{ns}$ ,  $t_f \leq 10\ \text{ns}$ .
  - C.  $t_{PLZ}$  and  $t_{PHZ}$  are the same as  $t_{dis}$ .
  - D.  $t_{PZL}$  and  $t_{PZH}$  are the same as  $t_{en}$ .

**Figure 7-4. Receiver Enable and Disable Times**

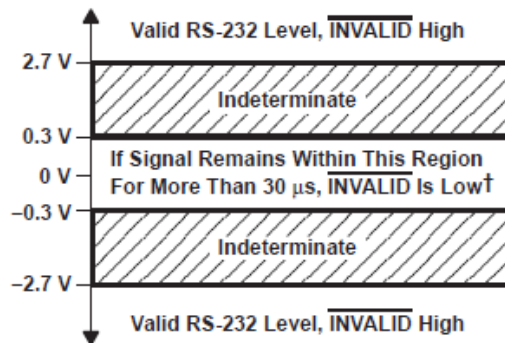
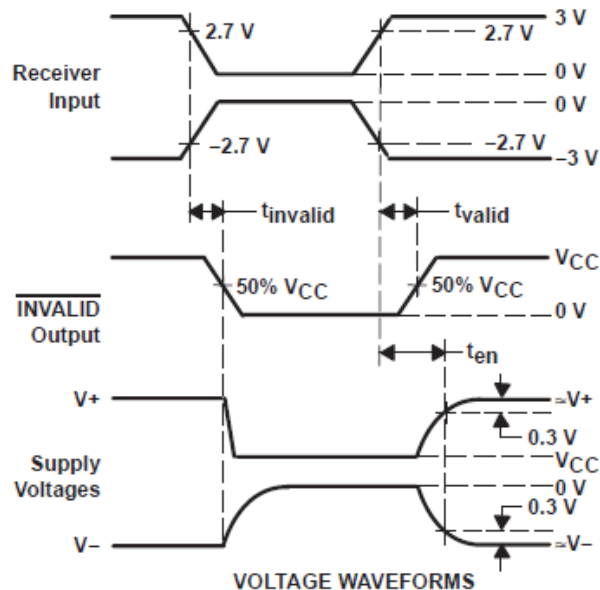
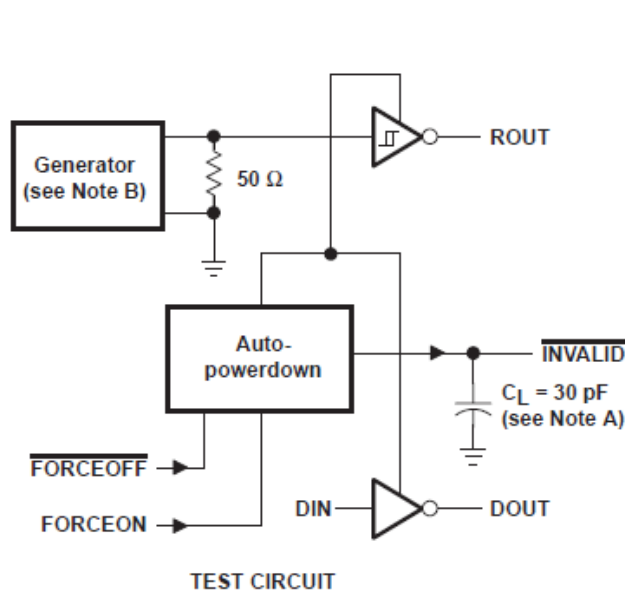

† Auto-powerdown disables drivers and reduces supply current to 1  $\mu\text{A}$ .

- NOTES: A.  $C_L$  includes probe and jig capacitance.  
 B. The pulse generator has the following characteristics: PRR = 5 kbit/s,  $Z_O = 50 \Omega$ , 50% duty cycle,  $t_r \leq 10 \text{ ns}$ ,  $t_f \leq 10 \text{ ns}$ .

Figure 7-5.  $\overline{\text{INVALID}}$  Propagation Delay Times and Driver Enabling Time

## 8 Detailed Description

### 8.1 Device Functional Modes

**Table 8-1. Each Driver<sup>(1)</sup>**

INPUTS				OUTPUT DOUT	DRIVER STATUS
DIN	FORCEON	FORCEOFF	VALID RIN RS-232 LEVEL		
X	X	L	X	Z	Powered off
L	H	H	X	H	Normal operation with auto- powerdown disabled
H	H	H	X	L	
L	L	H	Yes	H	Normal operation with auto- powerdown enabled
H	L	H	Yes	L	
L	L	H	No	Z	Powered off by auto- powerdown feature
H	L	H	No	Z	

(1) H = high level, L = low level, X = irrelevant, Z = high impedance

**Table 8-2. Each Receiver<sup>(1)</sup>**

INPUTS			OUTPUT ROUT
RIN	EN	VALID RIN RS-232 LEVEL	
L	L	X	H
H	L	X	L
X	H	X	Z
Open	L	No	H

(1) H = high level, L = low level, X = irrelevant, Z = high impedance (off), Open = disconnected input or connected driver off.

## 9 Application and Implementation

### Note

Information in the following applications sections is not part of the TI component specification, and TI does not warrant its accuracy or completeness. TI's customers are responsible for determining suitability of components for their purposes, as well as validating and testing their design implementation to confirm system functionality.

### 9.1 Application Information

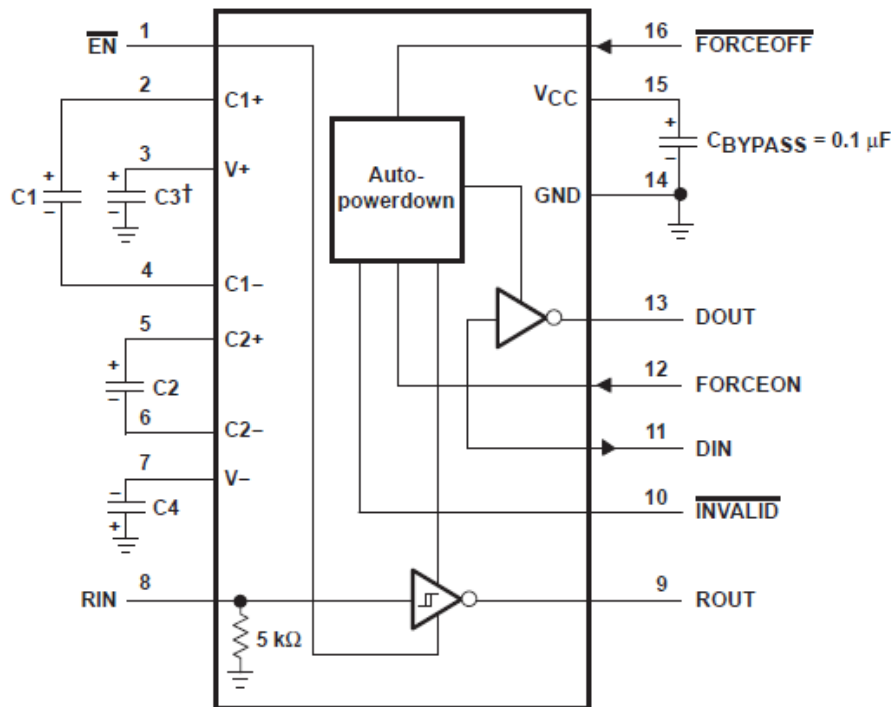

† C3 can be connected to V<sub>CC</sub> or GND

Resistor values shown are nominal.

**Figure 9-1. Typical Operating Circuit and Capacitor Values**

**Table 9-1. V<sub>CC</sub> vs Capacitor Values**

V <sub>CC</sub>	C1	C2, C3, and C4
3.3 V ± 0.3 V	0.1 μF	0.1 μF
5 V ± 0.5 V	0.047 μF	0.33 μF
3 V to 5.5 V	0.1 μF	0.47 μF

## 10 Device and Documentation Support

TI offers an extensive line of development tools. Tools and software to evaluate the performance of the device, generate code, and develop solutions are listed below.

### 10.1 Receiving Notification of Documentation Updates

To receive notification of documentation updates, navigate to the device product folder on [ti.com](http://ti.com). Click on *Subscribe to updates* to register and receive a weekly digest of any product information that has changed. For change details, review the revision history included in any revised document.

### 10.2 Support Resources

[TI E2E™ support forums](#) are an engineer's go-to source for fast, verified answers and design help — straight from the experts. Search existing answers or ask your own question to get the quick design help you need.

Linked content is provided "AS IS" by the respective contributors. They do not constitute TI specifications and do not necessarily reflect TI's views; see TI's [Terms of Use](#).

### 10.3 Trademarks

TI E2E™ is a trademark of Texas Instruments.  
All trademarks are the property of their respective owners.

### 10.4 Electrostatic Discharge Caution



This integrated circuit can be damaged by ESD. Texas Instruments recommends that all integrated circuits be handled with appropriate precautions. Failure to observe proper handling and installation procedures can cause damage.

ESD damage can range from subtle performance degradation to complete device failure. Precision integrated circuits may be more susceptible to damage because very small parametric changes could cause the device not to meet its published specifications.

### 10.5 Glossary

[TI Glossary](#) This glossary lists and explains terms, acronyms, and definitions.

## 11 Mechanical, Packaging, and Orderable Information

The following pages include mechanical, packaging, and orderable information. This information is the most current data available for the designated devices. This data is subject to change without notice and revision of this document. For browser-based versions of this data sheet, refer to the left-hand navigation.

**PACKAGING INFORMATION**

Orderable Device	Status (1)	Package Type	Package Drawing	Pins	Package Qty	Eco Plan (2)	Lead finish/ Ball material (6)	MSL Peak Temp (3)	Op Temp (°C)	Device Marking (4/5)	Samples
SN65C3221PWR	ACTIVE	TSSOP	PW	16	2000	RoHS & Green	NIPDAU	Level-1-260C-UNLIM	-40 to 85	CB3221	<a href="#">Samples</a>
SN75C3221DBR	ACTIVE	SSOP	DB	16	2000	RoHS & Green	NIPDAU	Level-1-260C-UNLIM	0 to 70	CA3221	<a href="#">Samples</a>
SN75C3221DW	PREVIEW	SOIC	DW	16	40	TBD	Call TI	Call TI	0 to 70		
SN75C3221PWR	ACTIVE	TSSOP	PW	16	2000	RoHS & Green	NIPDAU	Level-1-260C-UNLIM	0 to 70	CA3221	<a href="#">Samples</a>

(1) The marketing status values are defined as follows:

**ACTIVE:** Product device recommended for new designs.

**LIFEBUY:** TI has announced that the device will be discontinued, and a lifetime-buy period is in effect.

**NRND:** Not recommended for new designs. Device is in production to support existing customers, but TI does not recommend using this part in a new design.

**PREVIEW:** Device has been announced but is not in production. Samples may or may not be available.

**OBsolete:** TI has discontinued the production of the device.

(2) **RoHS:** TI defines "RoHS" to mean semiconductor products that are compliant with the current EU RoHS requirements for all 10 RoHS substances, including the requirement that RoHS substance do not exceed 0.1% by weight in homogeneous materials. Where designed to be soldered at high temperatures, "RoHS" products are suitable for use in specified lead-free processes. TI may reference these types of products as "Pb-Free".

**RoHS Exempt:** TI defines "RoHS Exempt" to mean products that contain lead but are compliant with EU RoHS pursuant to a specific EU RoHS exemption.

**Green:** TI defines "Green" to mean the content of Chlorine (Cl) and Bromine (Br) based flame retardants meet JS709B low halogen requirements of <=1000ppm threshold. Antimony trioxide based flame retardants must also meet the <=1000ppm threshold requirement.

(3) MSL, Peak Temp. - The Moisture Sensitivity Level rating according to the JEDEC industry standard classifications, and peak solder temperature.

(4) There may be additional marking, which relates to the logo, the lot trace code information, or the environmental category on the device.

(5) Multiple Device Markings will be inside parentheses. Only one Device Marking contained in parentheses and separated by a "~" will appear on a device. If a line is indented then it is a continuation of the previous line and the two combined represent the entire Device Marking for that device.

(6) Lead finish/Ball material - Orderable Devices may have multiple material finish options. Finish options are separated by a vertical ruled line. Lead finish/Ball material values may wrap to two lines if the finish value exceeds the maximum column width.

**Important Information and Disclaimer:**The information provided on this page represents TI's knowledge and belief as of the date that it is provided. TI bases its knowledge and belief on information provided by third parties, and makes no representation or warranty as to the accuracy of such information. Efforts are underway to better integrate information from third parties. TI has taken and continues to take reasonable steps to provide representative and accurate information but may not have conducted destructive testing or chemical analysis on incoming materials and chemicals. TI and TI suppliers consider certain information to be proprietary, and thus CAS numbers and other limited information may not be available for release.

In no event shall TI's liability arising out of such information exceed the total purchase price of the TI part(s) at issue in this document sold by TI to Customer on an annual basis.

**OTHER QUALIFIED VERSIONS OF SN65C3221 :**

- Automotive : [SN65C3221-Q1](#)

**NOTE: Qualified Version Definitions:**

- Automotive - Q100 devices qualified for high-reliability automotive applications targeting zero defects

**TAPE AND REEL INFORMATION**

**QUADRANT ASSIGNMENTS FOR PIN 1 ORIENTATION IN TAPE**

\*All dimensions are nominal

Device	Package Type	Package Drawing	Pins	SPQ	Reel Diameter (mm)	Reel Width W1 (mm)	A0 (mm)	B0 (mm)	K0 (mm)	P1 (mm)	W (mm)	Pin1 Quadrant
SN65C3221PWR	TSSOP	PW	16	2000	330.0	12.4	6.9	5.6	1.6	8.0	12.0	Q1
SN75C3221DBR	SSOP	DB	16	2000	330.0	16.4	8.35	6.6	2.4	12.0	16.0	Q1
SN75C3221PWR	TSSOP	PW	16	2000	330.0	12.4	6.9	5.6	1.6	8.0	12.0	Q1

**TAPE AND REEL BOX DIMENSIONS**

\*All dimensions are nominal

Device	Package Type	Package Drawing	Pins	SPQ	Length (mm)	Width (mm)	Height (mm)
SN65C3221PWR	TSSOP	PW	16	2000	356.0	356.0	35.0
SN75C3221DBR	SSOP	DB	16	2000	356.0	356.0	35.0
SN75C3221PWR	TSSOP	PW	16	2000	356.0	356.0	35.0



4220204/A 02/2017

NOTES:

1. All linear dimensions are in millimeters. Any dimensions in parenthesis are for reference only. Dimensioning and tolerancing per ASME Y14.5M.
2. This drawing is subject to change without notice.
3. This dimension does not include mold flash, protrusions, or gate burrs. Mold flash, protrusions, or gate burrs shall not exceed 0.15 mm per side.
4. This dimension does not include interlead flash. Interlead flash shall not exceed 0.25 mm per side.
5. Reference JEDEC registration MO-153.

# EXAMPLE BOARD LAYOUT

PW0016A

TSSOP - 1.2 mm max height

SMALL OUTLINE PACKAGE



LAND PATTERN EXAMPLE  
EXPOSED METAL SHOWN  
SCALE: 10X

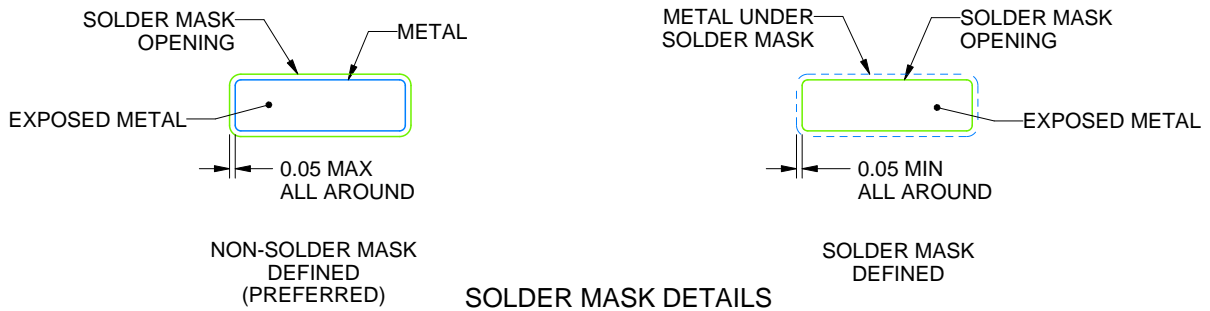

4220204/A 02/2017

NOTES: (continued)

- 6. Publication IPC-7351 may have alternate designs.
- 7. Solder mask tolerances between and around signal pads can vary based on board fabrication site.

# EXAMPLE STENCIL DESIGN

PW0016A

TSSOP - 1.2 mm max height

SMALL OUTLINE PACKAGE



SOLDER PASTE EXAMPLE  
BASED ON 0.125 mm THICK STENCIL  
SCALE: 10X

4220204/A 02/2017

NOTES: (continued)

8. Laser cutting apertures with trapezoidal walls and rounded corners may offer better paste release. IPC-7525 may have alternate design recommendations.
9. Board assembly site may have different recommendations for stencil design.

# DB0016A



# PACKAGE OUTLINE

## SSOP - 2 mm max height

SMALL OUTLINE PACKAGE



### NOTES:

1. All linear dimensions are in millimeters. Any dimensions in parenthesis are for reference only. Dimensioning and tolerancing per ASME Y14.5M.
2. This drawing is subject to change without notice.
3. This dimension does not include mold flash, protrusions, or gate burrs. Mold flash, protrusions, or gate burrs shall not exceed 0.15 mm per side.
4. Reference JEDEC registration MO-150.

# EXAMPLE BOARD LAYOUT

DB0016A

SSOP - 2 mm max height

SMALL OUTLINE PACKAGE



LAND PATTERN EXAMPLE  
EXPOSED METAL SHOWN  
SCALE: 10X



4220763/A 05/2022

NOTES: (continued)

- 5. Publication IPC-7351 may have alternate designs.
- 6. Solder mask tolerances between and around signal pads can vary based on board fabrication site.

# EXAMPLE STENCIL DESIGN

DB0016A

SSOP - 2 mm max height

SMALL OUTLINE PACKAGE



SOLDER PASTE EXAMPLE  
BASED ON 0.125 mm THICK STENCIL  
SCALE: 10X

4220763/A 05/2022

NOTES: (continued)

7. Laser cutting apertures with trapezoidal walls and rounded corners may offer better paste release. IPC-7525 may have alternate design recommendations.
8. Board assembly site may have different recommendations for stencil design.

## IMPORTANT NOTICE AND DISCLAIMER

TI PROVIDES TECHNICAL AND RELIABILITY DATA (INCLUDING DATA SHEETS), DESIGN RESOURCES (INCLUDING REFERENCE DESIGNS), APPLICATION OR OTHER DESIGN ADVICE, WEB TOOLS, SAFETY INFORMATION, AND OTHER RESOURCES "AS IS" AND WITH ALL FAULTS, AND DISCLAIMS ALL WARRANTIES, EXPRESS AND IMPLIED, INCLUDING WITHOUT LIMITATION ANY IMPLIED WARRANTIES OF MERCHANTABILITY, FITNESS FOR A PARTICULAR PURPOSE OR NON-INFRINGEMENT OF THIRD PARTY INTELLECTUAL PROPERTY RIGHTS.

These resources are intended for skilled developers designing with TI products. You are solely responsible for (1) selecting the appropriate TI products for your application, (2) designing, validating and testing your application, and (3) ensuring your application meets applicable standards, and any other safety, security, regulatory or other requirements.

These resources are subject to change without notice. TI grants you permission to use these resources only for development of an application that uses the TI products described in the resource. Other reproduction and display of these resources is prohibited. No license is granted to any other TI intellectual property right or to any third party intellectual property right. TI disclaims responsibility for, and you will fully indemnify TI and its representatives against, any claims, damages, costs, losses, and liabilities arising out of your use of these resources.

TI's products are provided subject to [TI's Terms of Sale](#) or other applicable terms available either on [ti.com](https://www.ti.com) or provided in conjunction with such TI products. TI's provision of these resources does not expand or otherwise alter TI's applicable warranties or warranty disclaimers for TI products.

TI objects to and rejects any additional or different terms you may have proposed.

Mailing Address: Texas Instruments, Post Office Box 655303, Dallas, Texas 75265  
Copyright © 2024, Texas Instruments Incorporated

## Looking for pricing, stock, or lifecycle information?

Click below to explore more details on WIN SOURCE:

 [View SN75C3221PWR on WIN SOURCE](#)

 [Texas Instruments](#) Information

## Optimize Your Supply Chain with WIN SOURCE Solutions

-  Global Sourcing Solution
-  Obsolete Management
-  Cost Control Management
-  Shortage Management
-  Alternative Solution
-  Excess Inventory Management