



**THE DATASHEET OF  
74LCX125MTCX**



# Low Voltage Quad Buffer with 5 V Tolerant Inputs and Outputs

## 74LCX125

### Description

The LCX125 contains four independent non-inverting buffers with 3-STATE outputs. The inputs tolerate Voltages up to 7 V Allowing the interface of 5 V Systems to 3 V Systems.

The 74LCX125 is fabricated with an advanced CMOS technology to achieve high Speed operation while Maintaining CMOS Low Power Dissipation.

### Features

- 5 V Tolerant Inputs and Outputs
- 2.3 V–3.6 V  $V_{CC}$  Specifications Provided
- 6.0 ns  $t_{PD}$  max. ( $V_{CC} = 3.3$  V), 10  $\mu$ A  $I_{CC}$  max.
- Power Down High Impedance Inputs and Outputs
- Supports Live Insertion/Withdrawal\*
- $\pm 24$  mA Output Drive ( $V_{CC} = 3.0$  V)
- Latch-up Performance Exceeds JEDEC 78 Conditions
- ESD Performance:
  - ◆ Human body model > 2000 V
  - ◆ Machine model > 100 V
- Leadless DQFN Package

\*To ensure the High-Impedance State During Power up or down,  $\overline{OE}$  Should be tied to  $V_{CC}$  through a pull-up resistor: the minimum value of the resistor is determined by the current-sourcing capability of the driver.

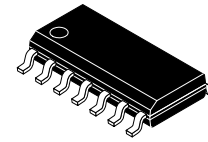

SOIC14,  
CASE 751EF

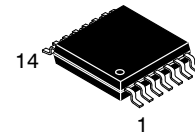

TSSOP-14, WB  
CASE 948G

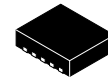

QFN14, 3.0X2.5, 0.5P  
CASE 510CB

### MARKING DIAGRAM



Z = Assembly Plan Code  
XY = Date Code (Year & Week)  
KK = Lot Run Traceability Code  
LCX125 = Specific Device Code

### ORDERING INFORMATION

See detailed ordering and shipping information on page 6 of this data sheet.

# 74LCX125

## Connection Diagrams

### Pin Assignments for SOIC, SOP, and TSSOP

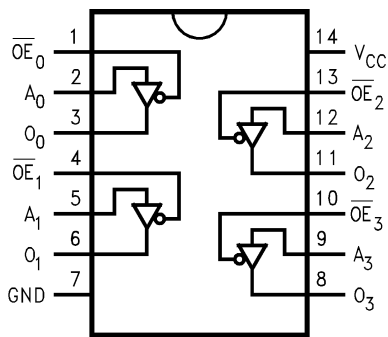

(Top View)

## Logic Symbol

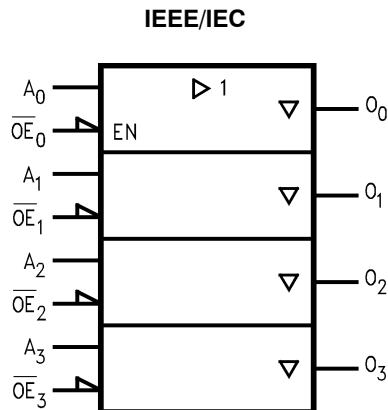

### Pad Assignments for DQFN

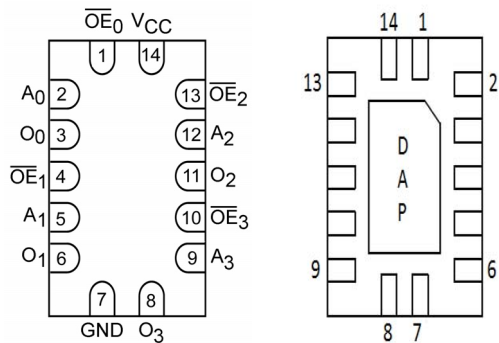

(Top Through View)

(Bottom View)

## Truth Table

Inputs		Output
$\overline{OE}_n$	$A_n$	$O_n$
L	L	L
L	H	H
H	X	Z

H = HIGH Voltage Level

L = HIGH Voltage Level

Z = HIGH Impedance

X = Immaterial

## Pin Description

Pin Names	Description
$A_n$	Inputs
$\overline{OE}_n$	Output Enable Inputs
$O_n$	Outputs
DAP	No Connect

Note: DAP (Die Attach Pad)

# 74LCX125

## ABSOLUTE MAXIMUM RATINGS

Symbol	Parameter	Ratings	Unit
V <sub>CC</sub>	Supply Voltage	-0.5 to +7.0	V
V <sub>I</sub>	DC Input Voltage	-0.5 to +7.0	V
V <sub>O</sub>	DC Output Voltage, - Output in 3-STATE - Output in HIGH or LOW State (Note 1)	-0.5 V to +7.0 -0.5 V to V <sub>CC</sub> + 0.5	V V
I <sub>IK</sub>	DC Input Diode Current, V <sub>I</sub> < GND	-50	mA
I <sub>OK</sub>	DC Input Diode Current - VO < GND - VO > V <sub>CC</sub>	-50 +50	mA mA
I <sub>O</sub>	DC Output Source/Sink Current	±50	mA
I <sub>CC</sub>	DC Supply Current per Supply Pin	±50	mA
I <sub>GND</sub>	DC Ground Current per Ground Pin	±100	mA
T <sub>STG</sub>	Storage Temperature	-65 to +150	°C

Stresses exceeding those listed in the Maximum Ratings table may damage the device. If any of these limits are exceeded, device functionality should not be assumed, damage may occur and reliability may be affected.

1. I<sub>O</sub> Absolute Maximum Rating must be observed.

## RECOMMENDED OPERATING CONDITIONS (Note 4)

Symbol	Parameter	Min.	Max.	Unit
V <sub>CC</sub>	Supply Voltage - Operating - Data Retention	2.0 1.5	3.6 3.6	V
V <sub>I</sub>	Input Voltage	0	5.5	V
V <sub>O</sub>	Output Voltage - HIGH or LOW State - 3-STATE	0 0	V <sub>CC</sub> 5.5	V
I <sub>OH</sub> / I <sub>OL</sub>	Common-mode Input Voltage - V <sub>CC</sub> = 3.0 V - 3.6 V - V <sub>CC</sub> = 2.7 V - 3.0 V - V <sub>CC</sub> = 2.3 V - 2.7 V		±24 ±12 ±8	mA
T <sub>A</sub>	Free-Air Operating Temperature	-40	85	°C
Δt / ΔV	Input Edge Rate, V <sub>IN</sub> = 0.8 V - 2.0 V, V <sub>CC</sub> = 3.0 V	0	10	ns/V

Functional operation above the stresses listed in the Recommended Operating Ranges is not implied. Extended exposure to stresses beyond the Recommended Operating Ranges limits may affect device reliability.

2. Unused inputs must be held HIGH or LOW. They may not float..

## DC ELECTRICAL CHARACTERISTICS

Symbol	Parameter	V <sub>CC</sub> (V)	Test Conditions	T <sub>A</sub> = -40°C to +85°C		Unit
				Min.	Max.	
V <sub>IH</sub>	HIGH Level Input Voltage	2.3-2.7		1.7		V
		2.7-3.6		2.0		
V <sub>IL</sub>	LOW Level Input Voltage	2.3-2.7		-	0.7	V
		2.7-3.6		-	0.8	
V <sub>OH</sub>	HIGH Level Output Voltage	2.3-3.6	I <sub>OH</sub> = -100 μA	V <sub>CC</sub> - 0.2	-	V
		2.3	I <sub>OH</sub> = -8 mA	1.8	-	
		2.7	I <sub>OH</sub> = -12 mA	2.2	-	
		3.0	I <sub>OH</sub> = -18 mA	2.4	-	
			I <sub>OH</sub> = -24 mA	2.2	-	

# 74LCX125

## DC ELECTRICAL CHARACTERISTICS (continued)

Symbol	Parameter	V <sub>CC</sub> (V)	Test Conditions	T <sub>A</sub> = -40°C to +85°C		Unit
				Min.	Max.	
V <sub>OL</sub>	LOW Level Output Voltage	2.3-3.6	I <sub>OL</sub> = 100 μA	-	0.2	V
		2.3	I <sub>OL</sub> = 8 mA	-	0.6	
		2.7	I <sub>OL</sub> = 12 mA	-	0.4	
		3.0	I <sub>OL</sub> = 16 mA	-	0.4	
			I <sub>OL</sub> = 24 mA	-	0.55	
I <sub>I</sub>	Input Leakage Current	2.3-3.6	0 ≤ V <sub>I</sub> ≤ 5.5 V	-	±5.0	μA
I <sub>oz</sub>	3-STATE Output Leakage	2.3-3.6	0 ≤ V <sub>O</sub> ≤ 5.5 V, V <sub>I</sub> = V <sub>IH</sub> or V <sub>IL</sub>	-	±5.0	μA
I <sub>OFF</sub>	Power-Off Leakage Current	0	V <sub>I</sub> or V <sub>O</sub> = 5.5 V	-	10	μA
I <sub>CC</sub>	Quiescent Supply Current	2.3-3.6	V <sub>I</sub> = V <sub>CC</sub> or GND	-	10	μA
			3.6 V ≤ V <sub>I</sub> , V <sub>O</sub> ≤ 5.5 V (Note 3)	-	±10	
ΔI <sub>CC</sub>	Increase in I <sub>CC</sub> per Input	2.3-3.6	V <sub>IH</sub> = V <sub>CC</sub> - 0.6 V	-	500	μA

3. Outputs disabled or 3-STATE only.

## AC ELECTRICAL CHARACTERISTICS

Symbol	Parameter	T <sub>A</sub> = -40°C to +85°C, R <sub>L</sub> = 500 Ω						Unit
		V <sub>CC</sub> = 3.3 V ± 0.3 V, C <sub>L</sub> = 50 pF		V <sub>CC</sub> = 2.7 V, C <sub>L</sub> = 50 pF		V <sub>CC</sub> = 2.5 V ± 0.2 V, C <sub>L</sub> = 30 pF		
		Min.	Max.	Min.	Max.	Min.	Max.	
t <sub>PHL</sub> , t <sub>PLH</sub>	Propagation Delay	1.5	6.0	1.5	6.5	1.5	7.2	ns
t <sub>PZL</sub> , t <sub>PZH</sub>	Output Enable Time	1.5	7.0	1.5	8.0	1.5	9.1	ns
t <sub>PLZ</sub> , t <sub>PHZ</sub>	Output Disable Time	1.5	6.0	1.5	7.0	1.5	7.2	ns
t <sub>OSSL</sub> , t <sub>OSLH</sub>	Output to Output Skew (Note 4)	-	1.0	-	-	-	-	ns

4. Skew is defined as the absolute value of the difference between the actual propagation delay for any two separate outputs of the same device. The specification applies to any outputs switching in the same direction, either HIGH-to-LOW (t<sub>OSSL</sub>) or LOW-to-HIGH (t<sub>OSLH</sub>).

## DYNAMIC SWITCHING CHARACTERISTICS

Symbol	Parameter	V <sub>CC</sub> (V)	Test Conditions	T <sub>A</sub> = 25°C	Unit
				Typical	
V <sub>OLP</sub>	Quiet Output Dynamic Peak V <sub>OL</sub>	3.3	C <sub>L</sub> = 50 pF, V <sub>IH</sub> = 3.3 V, V <sub>IL</sub> = 0 V	0.8	V
		2.5	C <sub>L</sub> = 30 pF, V <sub>IH</sub> = 2.5 V, V <sub>IL</sub> = 0 V	0.6	
V <sub>OLV</sub>	Quiet Output Dynamic Peak V <sub>OL</sub>	3.3	C <sub>L</sub> = 50 pF, V <sub>IH</sub> = 3.3 V, V <sub>IL</sub> = 0 V	-0.8	V
		2.5	C <sub>L</sub> = 30 pF, V <sub>IH</sub> = 2.5 V, V <sub>IL</sub> = 0 V	-0.6	

## CAPACITANCE

Symbol	Parameter	Test Conditions	Typical	Unit
C <sub>IN</sub>	Input Capacitance	V <sub>CC</sub> = Open, V <sub>I</sub> = 0 V or V <sub>CC</sub>	7.0	pF
C <sub>OUT</sub>	Output Capacitance	V <sub>CC</sub> = 3.3 V, V <sub>I</sub> = 0 V or V <sub>CC</sub>	8.0	pF
C <sub>PD</sub>	Power Dissipation Capacitance	V <sub>CC</sub> = 3.3 V, V <sub>I</sub> = 0 V or V <sub>CC</sub> , f = 10 MHz	25.0	pF

AC LOADING AND WAVEFORMS (GENERIC FOR LCX FAMILY)

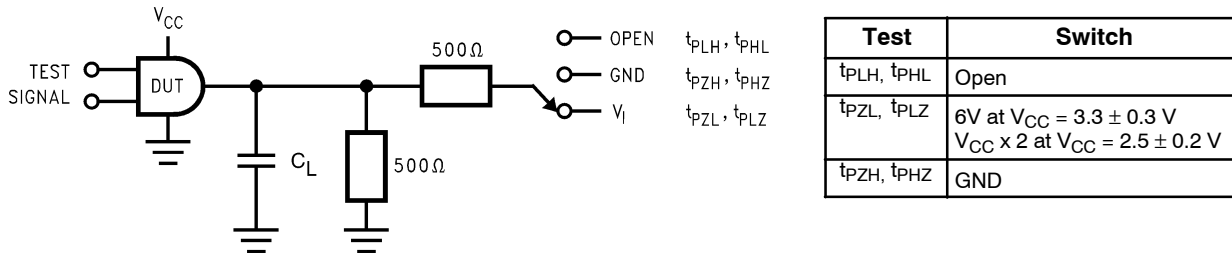
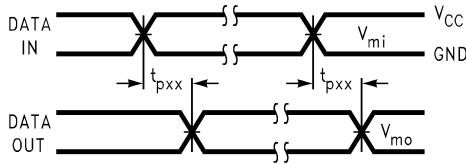
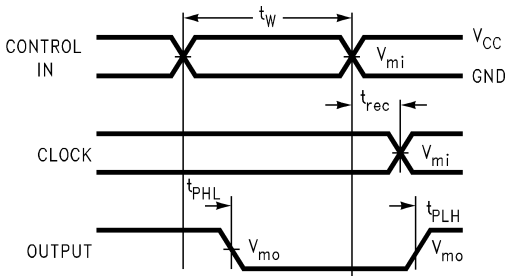

Figure 1. AC Test Circuit ( $C_L$  includes probe and jig capacitance)



Waveform for Inverting and Non-Inverting Functions



Propagation Delay, Pulse Width and  $t_{rec}$  Waveforms

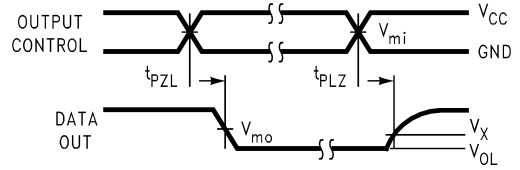

3-STATE Output High Enable and Disable Times for Logic

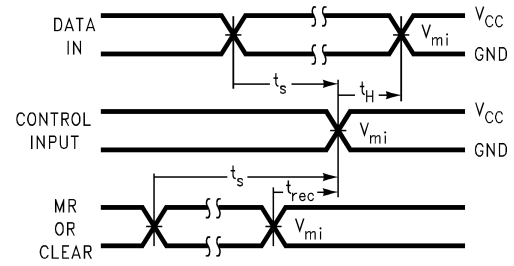

Setup Time, Hold Time and Recovery Time for Logic

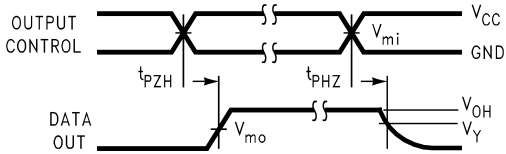

3-STATE Output Low Enable and Disable Times for Logic

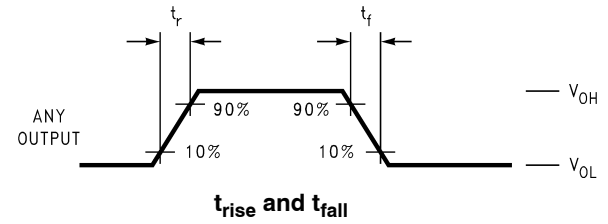

Symbol	$V_{CC}$		
	3.3 V + 0.3 V	2.7 V	2.5 V + 0.2 V
$V_{mi}$	1.5 V	1.5 V	$V_{CC}/2$
$V_{mo}$	1.5 V	1.5 V	$V_{CC}/2$
$V_x$	$V_{OL} + 0.3$ V	$V_{OL} + 0.3$ V	$V_{OL} + 0.15$ V
$V_y$	$V_{OH} - 0.3$ V	$V_{OH} - 0.3$ V	$V_{OH} - 0.15$ V

Figure 2. Waveforms (Input Characteristics;  $f = 1$  MHz,  $t_r = t_f = 3$  ns)

# 74LCX125

## SCHEMATIC DIAGRAM (GENERIC FOR LCX FAMILY)

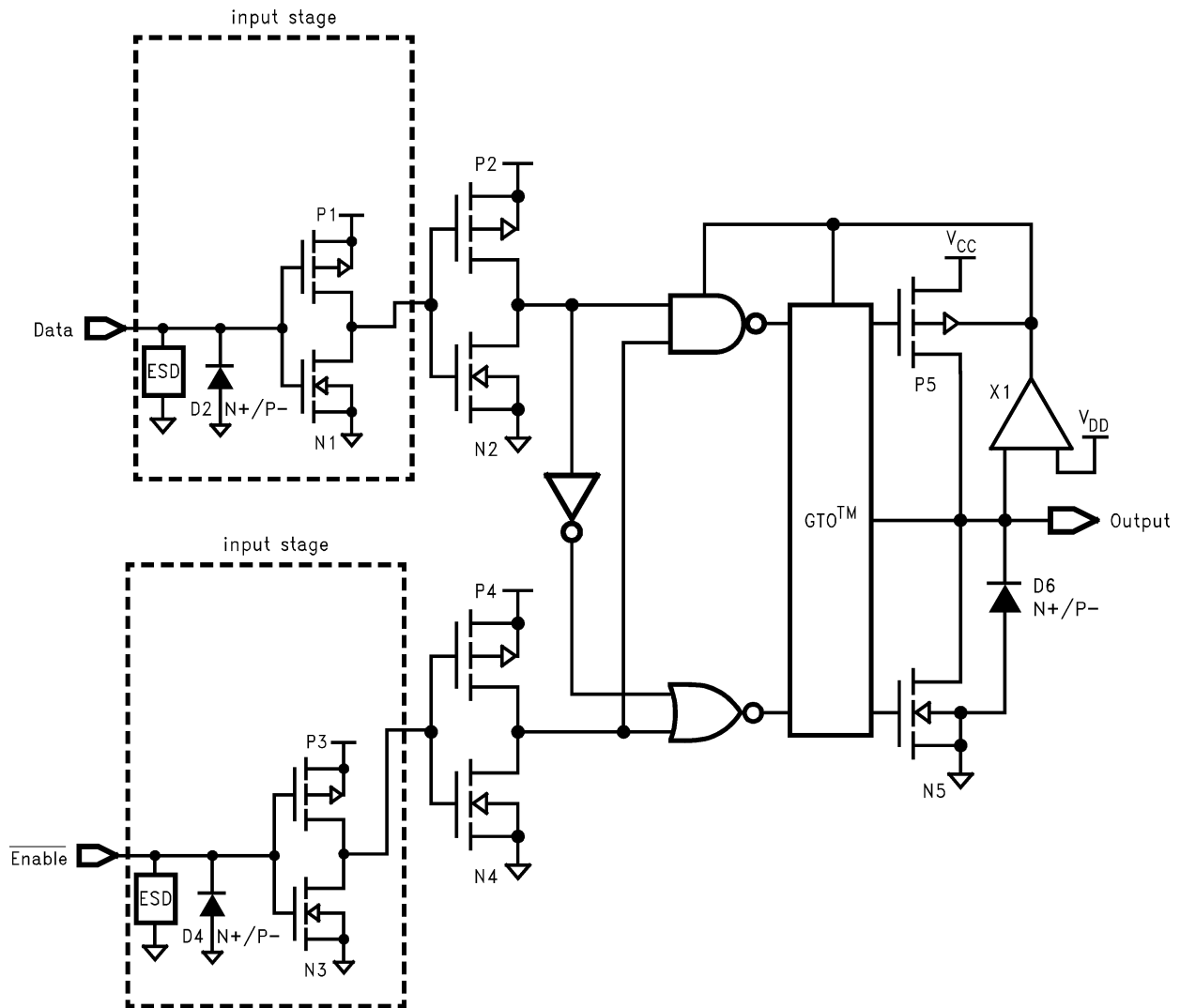

Figure 3. Schematic Diagram

### ORDERING INFORMATION

Product Number	Package	Shipping <sup>†</sup>
74LCX125M	SOIC-14 (Pb-Free/Halide Free)	1150 Units / Tube
74LCX125MX	SOIC-14 (Pb-Free/Halide Free)	2500 / Tape and Reel
74LCX125MTCX	TSSOP-14 WB (Pb-Free/Halide Free)	2500 / Tape and Reel
74LCX125BQX (Note 5)	QFN-14 (Pb-Free/Halide Free)	3000 / Tape and Reel
74LCX125MTC	TSSOP-14 WB (Pb-Free/Halide Free)	2350 Units / Tube

<sup>†</sup>For information on tape and reel specifications, including part orientation and tape sizes, please refer to our Tape and Reel Packaging Specifications Brochure, [BRD8011/D](#).

5. DQFN package available in Tape and Reel only.

# MECHANICAL CASE OUTLINE

## PACKAGE DIMENSIONS

ON Semiconductor®



**QFN14 3.0x2.5, 0.5P**  
CASE 510CB  
ISSUE O

DATE 31 AUG 2016

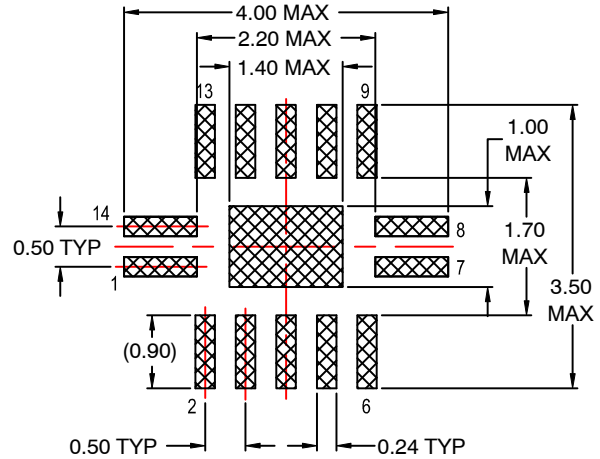
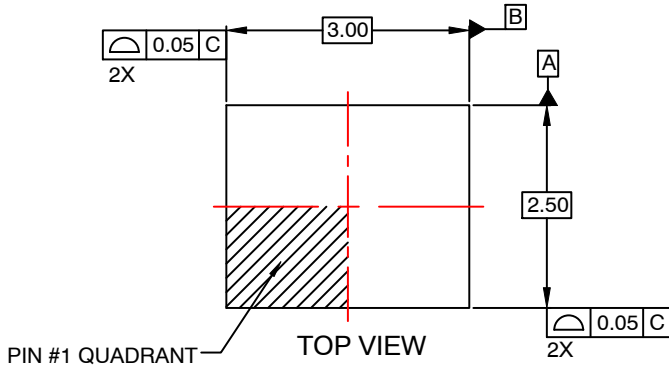

RECOMMENDED LAND PATTERN

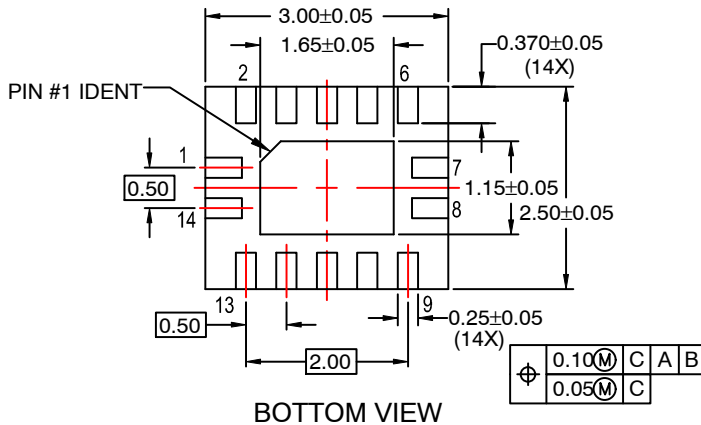
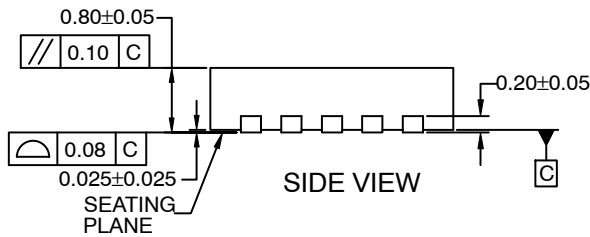

**NOTES:**

- A. CONFORMS TO JEDEC REGISTRATION MO-241, VARIATION AA
- B. DIMENSIONS ARE IN MILLIMETERS.
- C. DIMENSIONS AND TOLERANCES PER ASME Y14.5M, 2009.
- D. LAND PATTERN RECOMMENDATION IS EXISTING INDUSTRY LAND PATTERN.

<b>DOCUMENT NUMBER:</b>	<b>98AON13643G</b>	Electronic versions are uncontrolled except when accessed directly from the Document Repository. Printed versions are uncontrolled except when stamped "CONTROLLED COPY" in red.
<b>DESCRIPTION:</b>	<b>QFN14 3.0X2.5, 0.5P</b>	<b>PAGE 1 OF 1</b>

ON Semiconductor and are trademarks of Semiconductor Components Industries, LLC dba ON Semiconductor or its subsidiaries in the United States and/or other countries. ON Semiconductor reserves the right to make changes without further notice to any products herein. ON Semiconductor makes no warranty, representation or guarantee regarding the suitability of its products for any particular purpose, nor does ON Semiconductor assume any liability arising out of the application or use of any product or circuit, and specifically disclaims any and all liability, including without limitation special, consequential or incidental damages. ON Semiconductor does not convey any license under its patent rights nor the rights of others.

**MECHANICAL CASE OUTLINE**  
**PACKAGE DIMENSIONS**

ON Semiconductor®



**SOIC14**  
**CASE 751EF**  
**ISSUE O**

DATE 30 SEP 2016

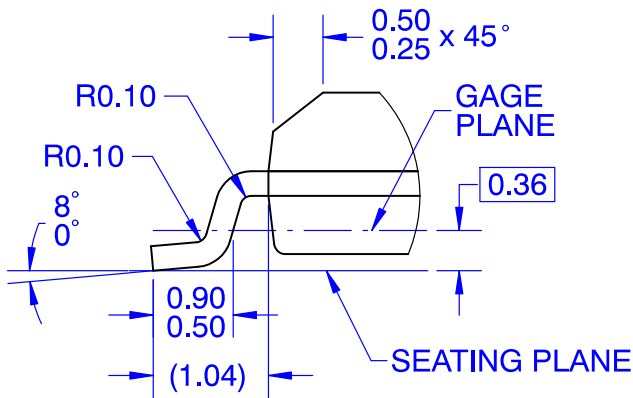
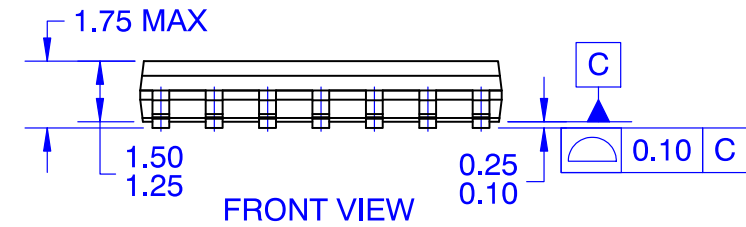
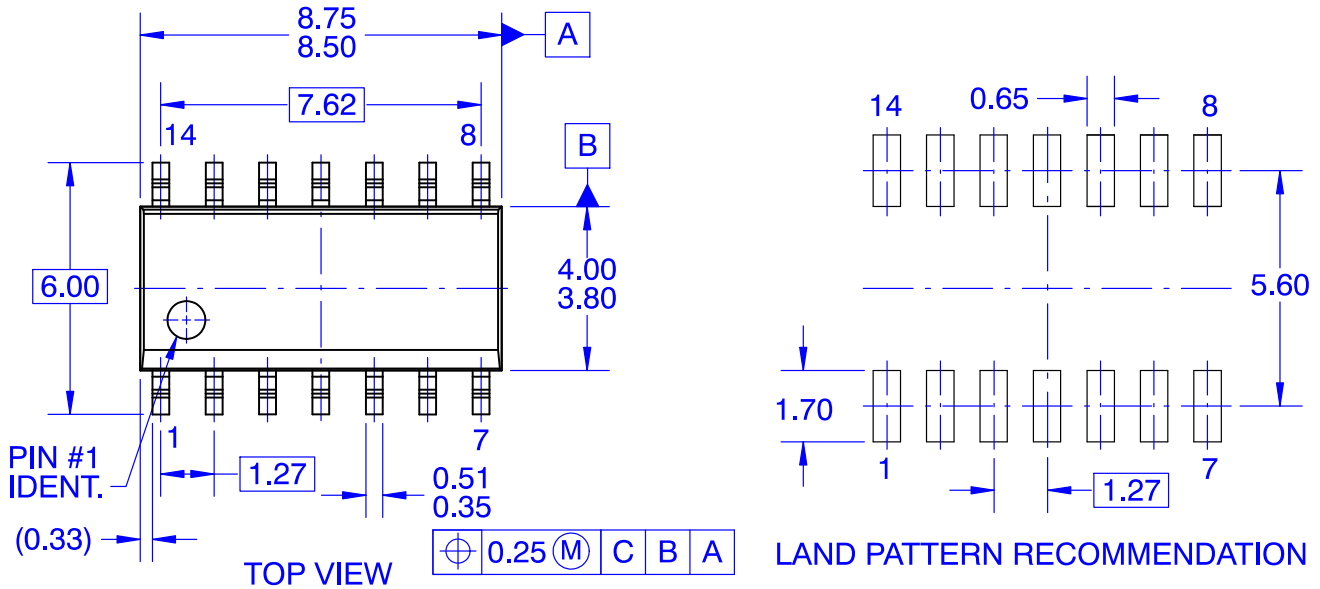

**NOTES:**

- A. CONFORMS TO JEDEC MS-012, VARIATION AB, ISSUE C
- B. ALL DIMENSIONS ARE IN MILLIMETERS
- C. DIMENSIONS DO NOT INCLUDE MOLD FLASH OR BURRS
- D. LAND PATTERN STANDARD: SOIC127P600X145-14M
- E. CONFORMS TO ASME Y14.5M, 2009

<b>DOCUMENT NUMBER:</b>	<b>98AON13739G</b>	Electronic versions are uncontrolled except when accessed directly from the Document Repository. Printed versions are uncontrolled except when stamped "CONTROLLED COPY" in red.
<b>DESCRIPTION:</b>	<b>SOIC14</b>	<b>PAGE 1 OF 1</b>

ON Semiconductor and are trademarks of Semiconductor Components Industries, LLC dba ON Semiconductor or its subsidiaries in the United States and/or other countries. ON Semiconductor reserves the right to make changes without further notice to any products herein. ON Semiconductor makes no warranty, representation or guarantee regarding the suitability of its products for any particular purpose, nor does ON Semiconductor assume any liability arising out of the application or use of any product or circuit, and specifically disclaims any and all liability, including without limitation special, consequential or incidental damages. ON Semiconductor does not convey any license under its patent rights nor the rights of others.

# MECHANICAL CASE OUTLINE PACKAGE DIMENSIONS

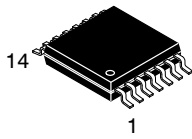

**TSSOP-14 WB**  
CASE 948G  
ISSUE C

DATE 17 FEB 2016

SCALE 2:1

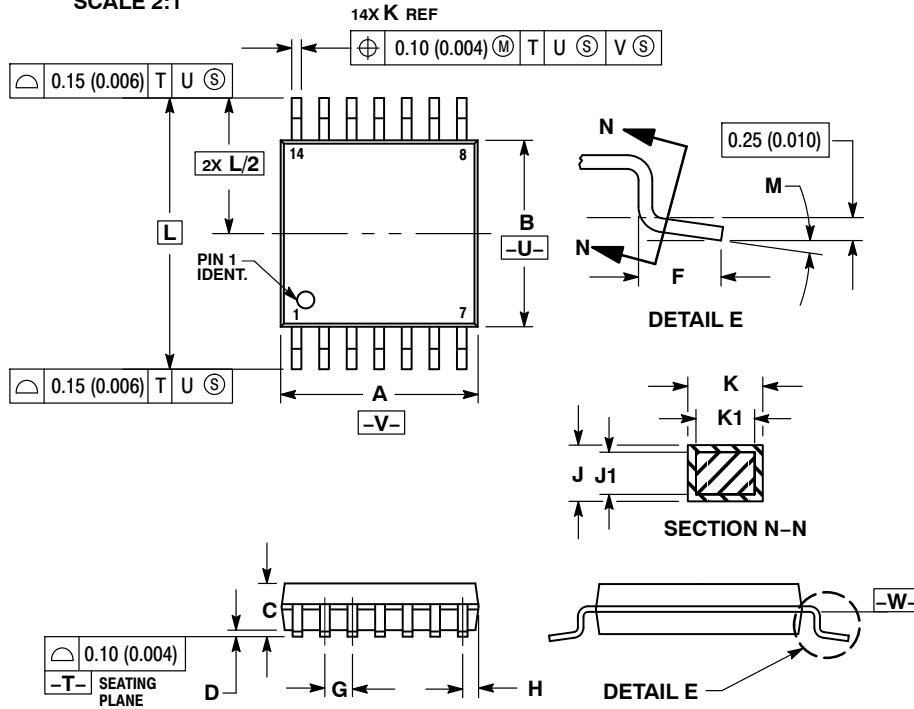

**NOTES:**

- DIMENSIONING AND TOLERANCING PER ANSI Y14.5M, 1982.
- CONTROLLING DIMENSION: MILLIMETER.
- DIMENSION A DOES NOT INCLUDE MOLD FLASH, PROTRUSIONS OR GATE BURRS. MOLD FLASH OR GATE BURRS SHALL NOT EXCEED 0.15 (0.006) PER SIDE.
- DIMENSION B DOES NOT INCLUDE INTERLEAD FLASH OR PROTRUSION. INTERLEAD FLASH OR PROTRUSION SHALL NOT EXCEED 0.25 (0.010) PER SIDE.
- DIMENSION K DOES NOT INCLUDE DAMBAR PROTRUSION. ALLOWABLE DAMBAR PROTRUSION SHALL BE 0.08 (0.003) TOTAL IN EXCESS OF THE K DIMENSION AT MAXIMUM MATERIAL CONDITION.
- TERMINAL NUMBERS ARE SHOWN FOR REFERENCE ONLY.
- DIMENSION A AND B ARE TO BE DETERMINED AT DATUM PLANE -W-.

DIM	MILLIMETERS		INCHES	
	MIN	MAX	MIN	MAX
A	4.90	5.10	0.193	0.200
B	4.30	4.50	0.169	0.177
C	---	1.20	---	0.047
D	0.05	0.15	0.002	0.006
F	0.50	0.75	0.020	0.030
G	0.65 BSC		0.026 BSC	
H	0.50	0.60	0.020	0.024
J	0.09	0.20	0.004	0.008
J1	0.09	0.16	0.004	0.006
K	0.19	0.30	0.007	0.012
K1	0.19	0.25	0.007	0.010
L	6.40 BSC		0.252 BSC	
M	0°	8°	0°	8°

**GENERIC MARKING DIAGRAM\***

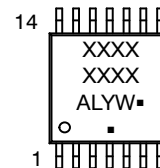

- A = Assembly Location
- L = Wafer Lot
- Y = Year
- W = Work Week
- = Pb-Free Package

(Note: Microdot may be in either location)

\*This information is generic. Please refer to device data sheet for actual part marking. Pb-Free indicator, "G" or microdot "▪", may or may not be present. Some products may not follow the Generic Marking.

**SOLDERING FOOTPRINT**

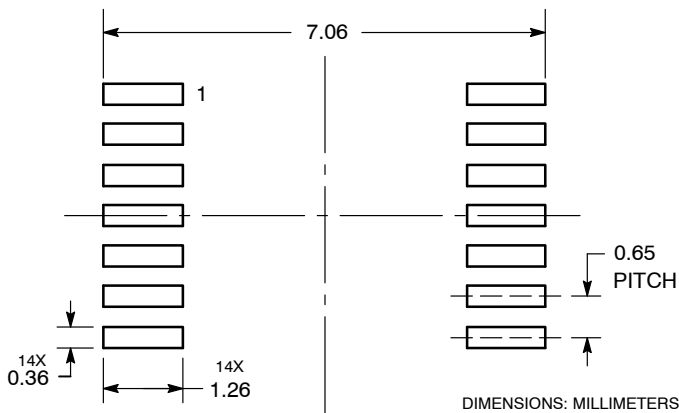

<b>DOCUMENT NUMBER:</b>	<b>98ASH70246A</b>	Electronic versions are uncontrolled except when accessed directly from the Document Repository. Printed versions are uncontrolled except when stamped "CONTROLLED COPY" in red.
<b>DESCRIPTION:</b>	<b>TSSOP-14 WB</b>	<b>PAGE 1 OF 1</b>

onsemi and onsemi are trademarks of Semiconductor Components Industries, LLC dba onsemi or its subsidiaries in the United States and/or other countries. onsemi reserves the right to make changes without further notice to any products herein. onsemi makes no warranty, representation or guarantee regarding the suitability of its products for any particular purpose, nor does onsemi assume any liability arising out of the application or use of any product or circuit, and specifically disclaims any and all liability, including without limitation special, consequential or incidental damages. onsemi does not convey any license under its patent rights nor the rights of others.

**onsemi**, **Onsemi**, and other names, marks, and brands are registered and/or common law trademarks of Semiconductor Components Industries, LLC dba "**onsemi**" or its affiliates and/or subsidiaries in the United States and/or other countries. **onsemi** owns the rights to a number of patents, trademarks, copyrights, trade secrets, and other intellectual property. A listing of **onsemi**'s product/patent coverage may be accessed at [www.onsemi.com/site/pdf/Patent-Marking.pdf](http://www.onsemi.com/site/pdf/Patent-Marking.pdf). **onsemi** reserves the right to make changes at any time to any products or information herein, without notice. The information herein is provided "as-is" and **onsemi** makes no warranty, representation or guarantee regarding the accuracy of the information, product features, availability, functionality, or suitability of its products for any particular purpose, nor does **onsemi** assume any liability arising out of the application or use of any product or circuit, and specifically disclaims any and all liability, including without limitation special, consequential or incidental damages. Buyer is responsible for its products and applications using **onsemi** products, including compliance with all laws, regulations and safety requirements or standards, regardless of any support or applications information provided by **onsemi**. "Typical" parameters which may be provided in **onsemi** data sheets and/or specifications can and do vary in different applications and actual performance may vary over time. All operating parameters, including "Typicals" must be validated for each customer application by customer's technical experts. **onsemi** does not convey any license under any of its intellectual property rights nor the rights of others. **onsemi** products are not designed, intended, or authorized for use as a critical component in life support systems or any FDA Class 3 medical devices or medical devices with a same or similar classification in a foreign jurisdiction or any devices intended for implantation in the human body. Should Buyer purchase or use **onsemi** products for any such unintended or unauthorized application, Buyer shall indemnify and hold **onsemi** and its officers, employees, subsidiaries, affiliates, and distributors harmless against all claims, costs, damages, and expenses, and reasonable attorney fees arising out of, directly or indirectly, any claim of personal injury or death associated with such unintended or unauthorized use, even if such claim alleges that **onsemi** was negligent regarding the design or manufacture of the part. **onsemi** is an Equal Opportunity/Affirmative Action Employer. This literature is subject to all applicable copyright laws and is not for resale in any manner.

## ADDITIONAL INFORMATION

### TECHNICAL PUBLICATIONS:

Technical Library: [www.onsemi.com/design/resources/technical-documentation](http://www.onsemi.com/design/resources/technical-documentation)  
onsemi Website: [www.onsemi.com](http://www.onsemi.com)

### ONLINE SUPPORT: [www.onsemi.com/support](http://www.onsemi.com/support)

For additional information, please contact your local Sales Representative at [www.onsemi.com/support/sales](http://www.onsemi.com/support/sales)

## Looking for pricing, stock, or lifecycle information?

Click below to explore more details on WIN SOURCE:

-  [View 74LCX125MTCX on WIN SOURCE](#)
-  [Fairchild/ON Semiconductor Information](#)

## Optimize Your Supply Chain with WIN SOURCE Solutions

-  Global Sourcing Solution
-  Obsolete Management
-  Cost Control Management
-  Shortage Management
-  Alternative Solution
-  Excess Inventory Management