



# THE DATASHEET OF ST763ACDTR





# ST763A SERIES

## 3.3V STEP DOWN CURRENT MODE PWM DC-DC CONVERTERS

- OUTPUT VOLTAGE 3.3V
- SUPPLY VOLTAGE RANGE FROM 3.3V TO 11V
- GUARANTEED OUTPUT CURRENT: 500mA
- TYPICAL OPERATION FREQUENCY: 200KHz
- VERY LOW QUIESCENT CURRENT: 0.6mA ON MODE 0.2 $\mu$ A OFF MODE
- SWITCH ON/OFF CONTROL
- TYPICAL EFFICENCY: 90%
- OPERATING TEMPERATURE RANGE: -40°C TO 85°C
- AVAILABLE IN SO-8 AND DIP-8 PACKAGES

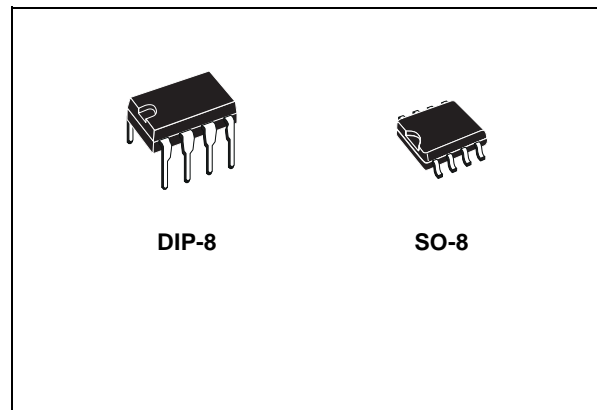

### DESCRIPTION

The ST763A is a step-down switching regulator. It operates from 3.3V to 11V giving a fixed 3.3V output voltage, delivering up to 500mA. The main features are typical efficiency of 90%, quiescent current of 0.6mA, and only 0.2 $\mu$ A in shut-down.

The PWM current mode control provides precise output regulation and very good transient response. Output voltage accuracy is guaranteed to be  $\pm 5\%$  over line, load and temperature variations. A minimum number of external

components is used and the fixed frequency switching allows easy filtering of output ripple and noise.

Other features of this device are cycle-by-cycle current limiting, overcurrent limiting, under voltage lockout and programmable soft-start protection. A 22 $\mu$ H inductor works in most applications, so no sophisticated design is necessary.

Package available are SO-8 and DIP-8. Typical application are in 5V to 3.3V converters, cellular phones, portable instruments, hand-held computers, and peripherals.

### SCHEMATIC DIAGRAM

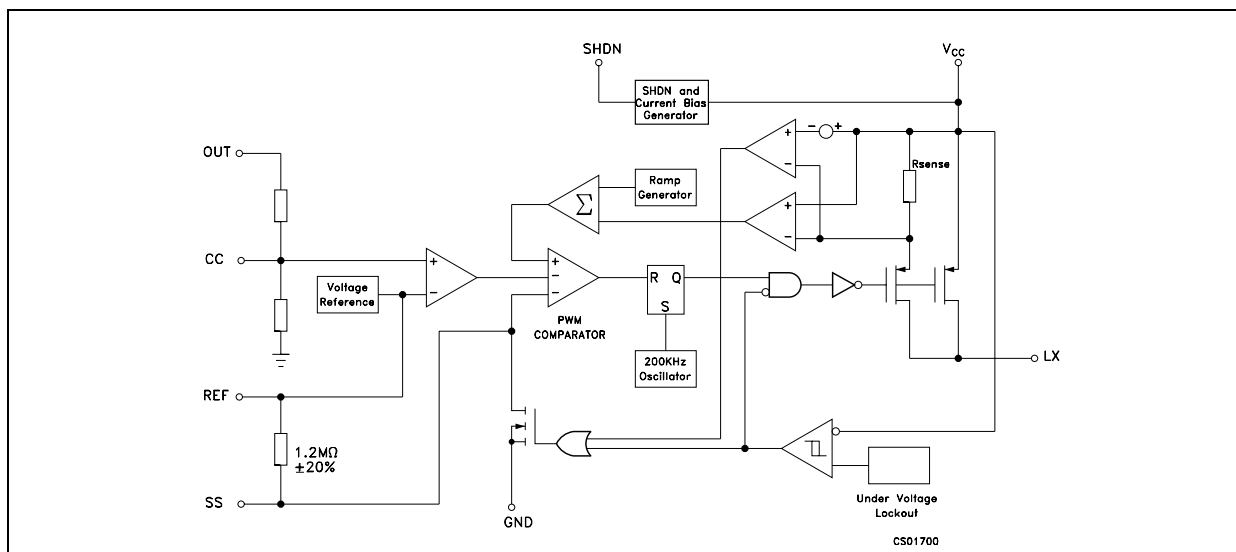

## ST763A SERIES

### ABSOLUTE MAXIMUM RATINGS

Symbol	Parameter <sup>2</sup>	Value	Unit
V <sub>CC</sub>	DC Input Voltage	-0.3 to 12	V
V <sub>LX</sub>	Switch Pin Voltage	-0.3 to (V <sub>CC</sub> + 0.3)	V
V <sub>SHDN</sub>	Shutdown Voltage (SHDN)	-0.3 to (V <sub>CC</sub> + 0.3)	V
V <sub>S</sub> , V <sub>C</sub>	Soft Start (SS) and Compensation Capacitor (CC) Pins Voltage	-0.3 to (V <sub>CC</sub> + 0.3)	V
I <sub>LX</sub>	Switching Peak Current	2	A
I <sub>REF</sub>	Reference Current	2.5	mA
P <sub>TOT</sub>	Continuous Power Dissipation at T <sub>A</sub> =70°C (DIP-8) (SO-8)	550 344	mW mW
T <sub>stg</sub>	Storage Temperature Range	-40 to +150	°C
T <sub>op</sub>	Operating Junction Temperature Range (AC series) (AB series)	0 to +70 -40 to +85	°C °C

Absolute Maximum Ratings are those values beyond which damage to the device may occur. Functional operation under these condition is not implied.

### THERMAL DATA

Symbol	Parameter	SO-8	DIP-8	Unit
R <sub>thj-amb</sub>	Thermal Resistance Junction-ambient (*)	160	100	°C/W

(\*) This value depends from thermal design of PCB on which the device is mounted.

### ORDERING CODES

TYPE	DIP8	SO-8	SO-8 (T&R)
ST763AB	ST763ABN	ST763ABD	ST763ABDTR
ST763AC	ST763ACN	ST763ACD	ST763ACDTR

## CONNECTION DIAGRAM (top view)

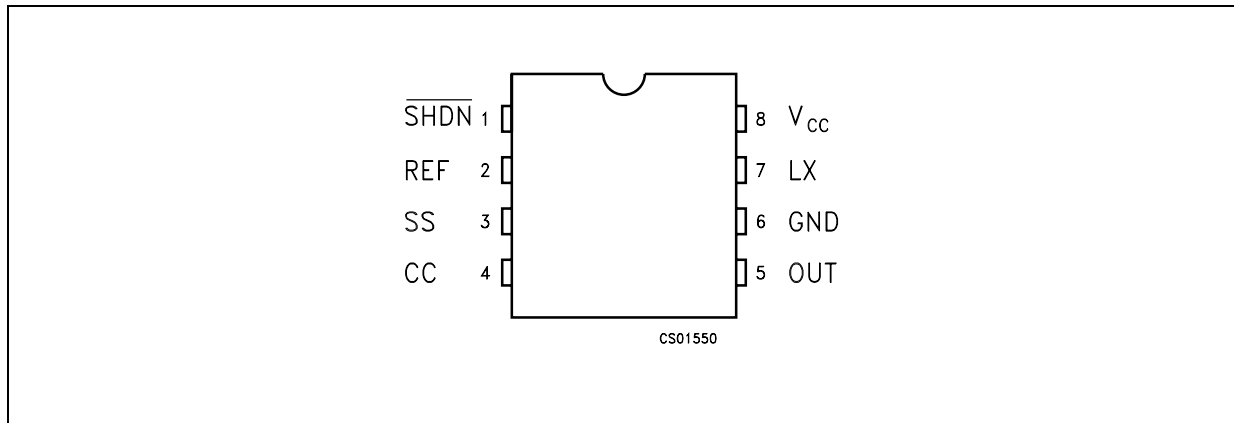

## PIN DESCRIPTION

Pin N°	Symbol	Name and Function
1	SHDN	Shutdown control (active low): If connected to GND the IC is in shutdown. Connect to V <sub>CC</sub> for normal operation (ON MODE)
2	REF	Reference Output Voltage:(1.25V): Bypass to GND with 47nF capacitor
3	SS	Soft Start: a capacitor between SS and GND provides soft-start and short-circuit protections.
4	CC	Compensation Capacitor Input: externally compensates the outer (voltage) feedback loop. Connect to OUT with 330pF capacitor
5	OUT	Output Voltage Sense Input: provides regulation of feedback sensing. Connect to 3.3V output.
6	GND	Ground
7	LX	Switch Output. Drain of internal P-Channel Power MOSFET
8	V <sub>CC</sub>	Supply Voltage Input. Bypass to GND with 1μF ceramic capacitance and large value electrolytic capacitor in parallel. The 1μF capacitor must be as close as possible to the GND and V <sub>CC</sub> pins

## ST763A SERIES

**ELECTRICAL CHARACTERISTICS** ( $V_{CC}=5V$ ,  $I_O=0mA$ ,  $T_A=T_{MIN}$  to  $T_{MAX}$ , unless otherwise specified.)

Symbol	Parameter	Test Conditions	Min.	Typ.	Max.	Unit
$V_{CC}$	Input Voltage		3.3		11	V
$V_O$	Output Voltage	$V_{CC} = 4$ to $11V$ $I_O = 0$ to $300mA$ $V_{CC} = 4.75$ to $11V$ $I_O = 0$ to $500mA$	3.135 3.135	3.3 3.3	3.465 3.465	V V
$\Delta V_O$	Line Regulation			0.13		%/V
$\Delta V_O$	Load Regulatio	$I_O = 1$ to $500mA$		0.005		%/mA
$\eta$	Power Efficiency	$I_O = 300mA$ $I_O = 100mA$		88 90		% %
$I_{SUPPLY}$	Supply Current	ON Mode (Including Switch Current) OFF Mode		0.6 0.2	2.5 100	mA $\mu A$
$V_{IH}$	SHDN Input High Threshold		2			V
$V_{IL}$	SHDN Input Low Threshold				0.25	V
$I_{SHDN}$	Shutdown Input Leakage Current				1	$\mu A$
$V_{LOCK}$	Under Voltage Lockout	$V_{CC}$ Falling		2.7	3	V
$R_{DS(on)}$	LX On Resistance	$I_{LX}=500mA$		1		$\Omega$
$I_{LEAK}$	LX Leakage Current	$V_{CC} = 12V$ $V_{LX} = 0V$		10		nA
$V_{REF}$	Reference Voltage	$T_A = 25^\circ C$	1.18	1.25	1.32	V
$\Delta V_{REF}$	Temperature Reference Drift	$T_A = T_{MIN}$ to $T_{MAX}$		50		ppm/ $^\circ C$
$f_{OSC}$	Switching Frequency		159	200	212.5	KHz
$R_C$	Compensation Pin Impedance			7500		$\Omega$

### TYPICAL APPLICATION CIRCUIT

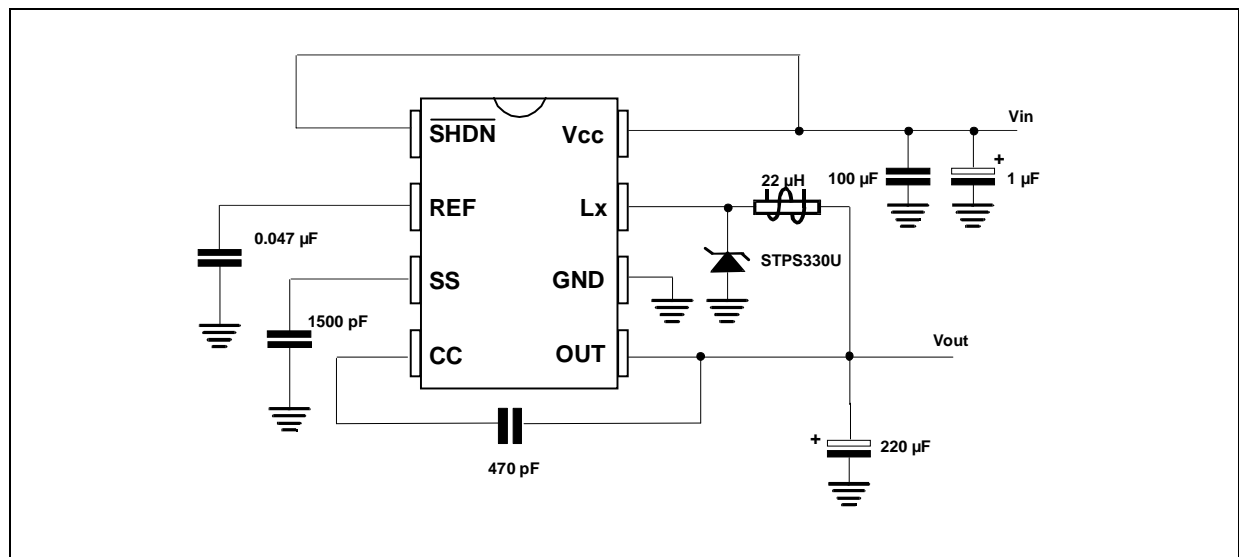

**TYPICAL PERFORMANCE CHARACTERISTICS** (unless otherwise specified  $T_j = 25^\circ\text{C}$ )

**Figure 1 : Output Voltage vs Temperature**

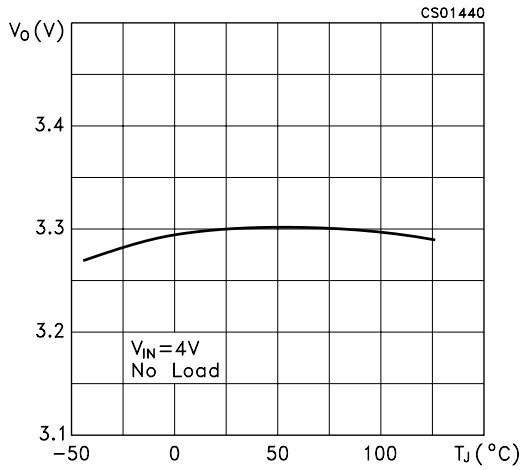

**Figure 2 : Output Voltage vs Input Voltage**

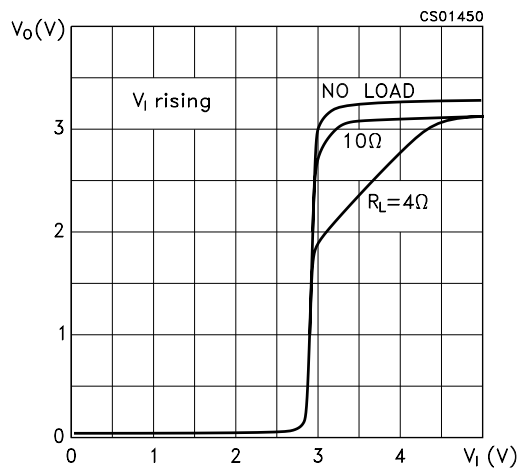

**Figure 3 : Reference Voltage vs Temperature**

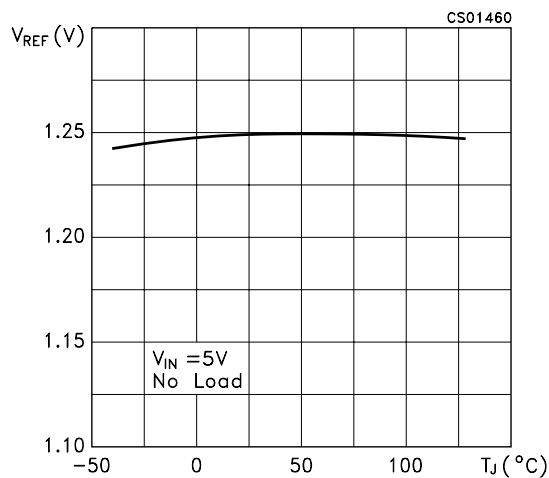

**Figure 4 : Efficiency vs Temperature**

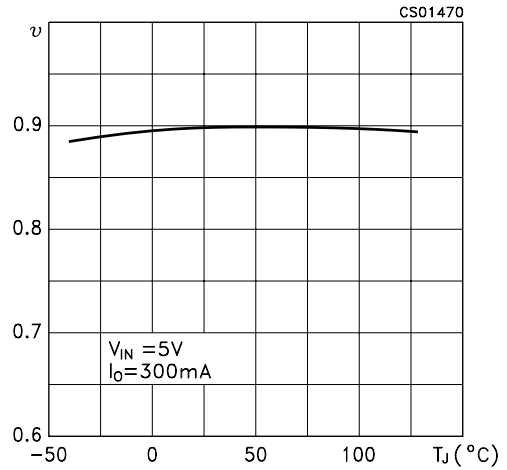

**Figure 5 : Efficiency vs Output Current**

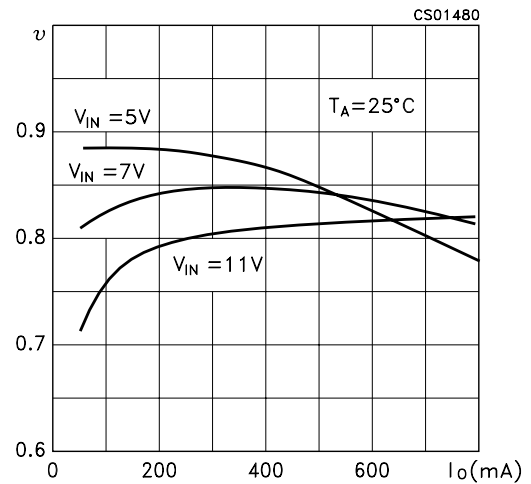

**Figure 6 : LX Leakage Current vs Temperature**

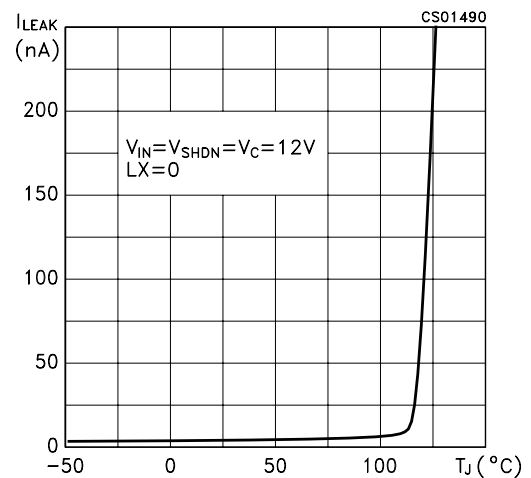

Figure 7 : LX ON Resistance vs Temperature

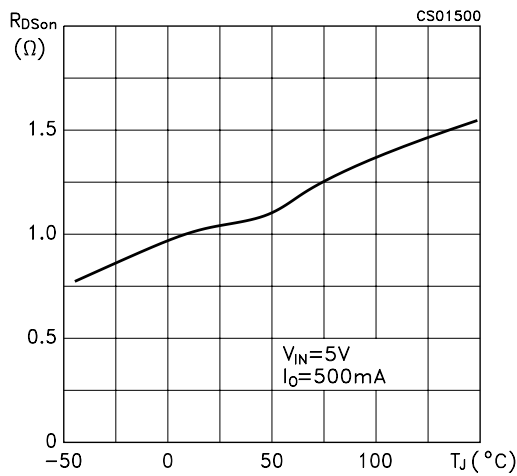

Figure 10 : Oscillator Frequency vs Temperature

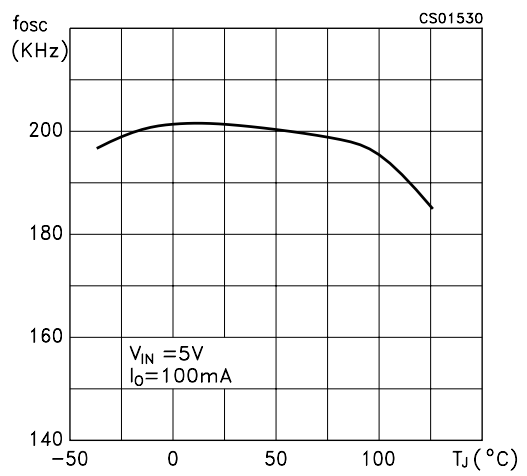

Figure 8 : Shutdown Input Threshold vs Temperature

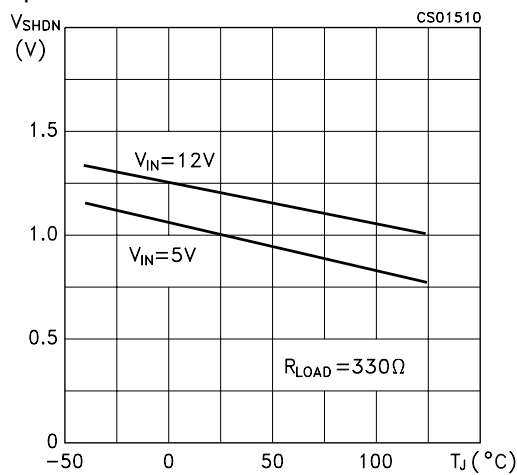

Figure 11 : Oscillator Frequency vs Input Voltage

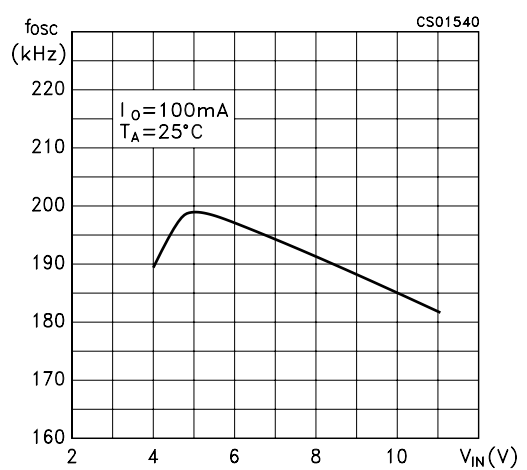

Figure 9 : Shutdown Input Leakage Current vs Temperature

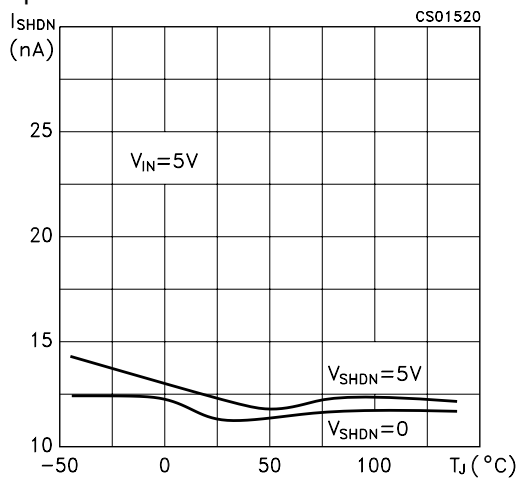
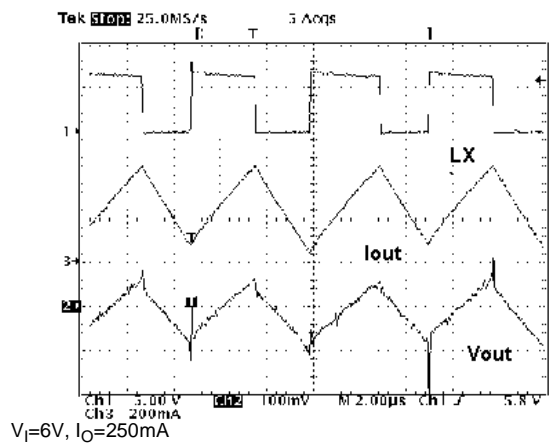
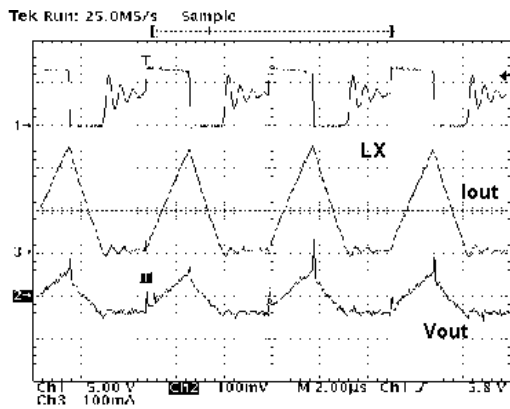

Figure 12 : Switching Waveforms, Continuous Conduction

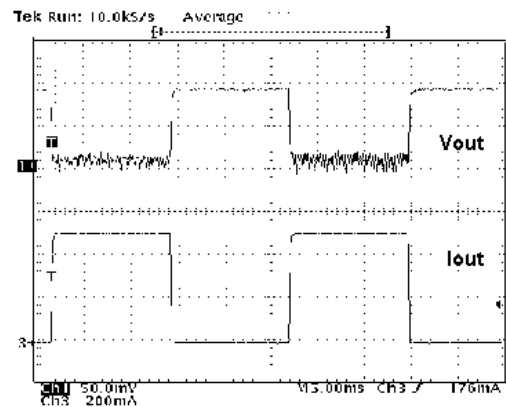

**Figure 13 : Switching Waveforms, Discontinuous Conduction**



$V_I=6V, I_O=75mA$

**Figure 15 : Load Transient**



$V_I=5V, I_O=0 \text{ to } 500mA$

**Figure 14 : Line Transient**

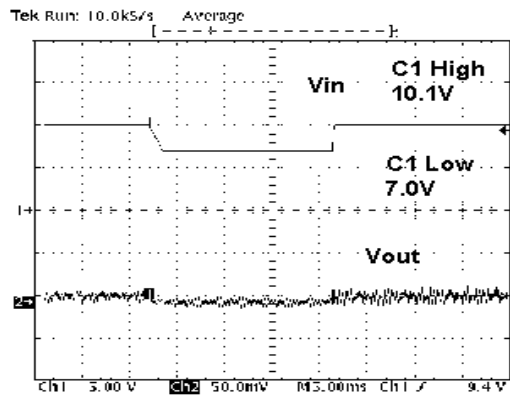

$i_O=350mA$

Plastic DIP-8 MECHANICAL DATA

DIM.	mm			inch		
	MIN.	TYP.	MAX.	MIN.	TYP.	MAX.
A		3.3			0.130	
a1	0.7			0.028		
B	1.39		1.65	0.055		0.065
B1	0.91		1.04	0.036		0.041
b		0.5			0.020	
b1	0.38		0.5	0.015		0.020
D			9.8			0.386
E		8.8			0.346	
e		2.54			0.100	
e3		7.62			0.300	
e4		7.62			0.300	
F			7.1			0.280
l			4.8			0.189
L		3.3			0.130	
Z	0.44		1.6	0.017		0.063

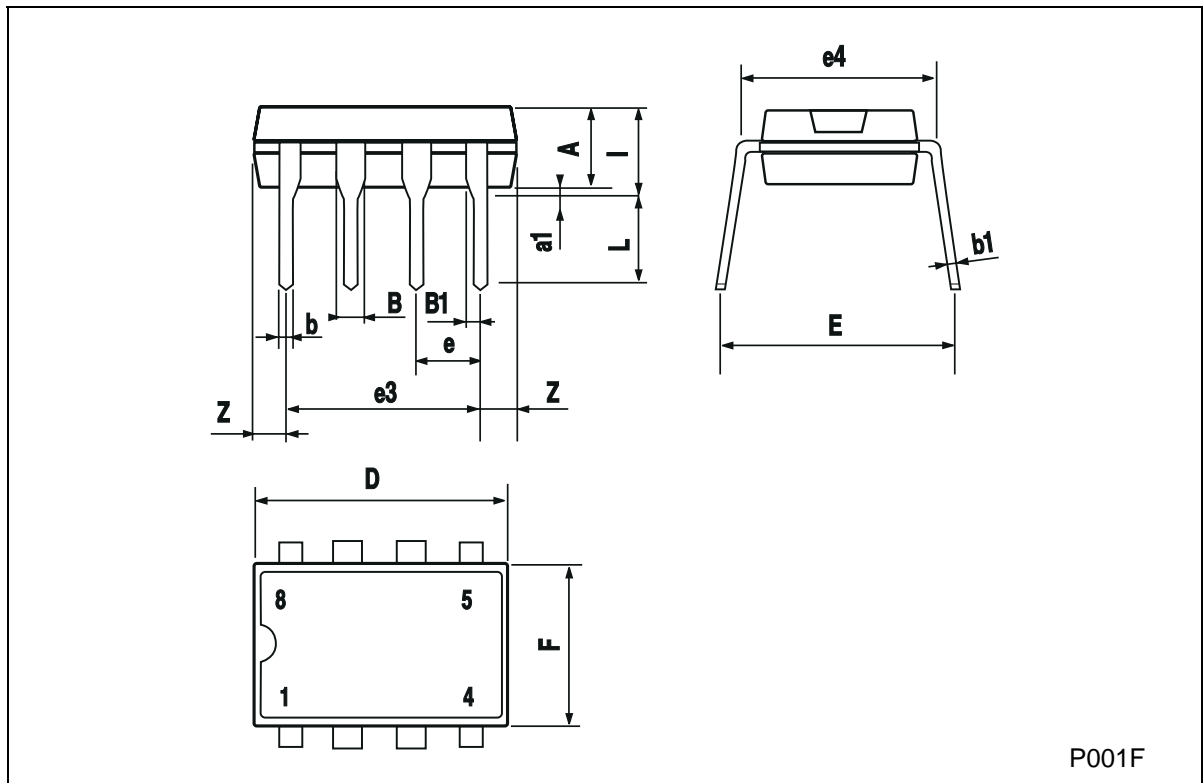

## SO-8 MECHANICAL DATA

DIM.	mm			inch		
	MIN.	TYP.	MAX.	MIN.	TYP.	MAX.
A			1.75			0.068
a1	0.1		0.25	0.003		0.009
a2			1.65			0.064
a3	0.65		0.85	0.025		0.033
b	0.35		0.48	0.013		0.018
b1	0.19		0.25	0.007		0.010
C	0.25		0.5	0.010		0.019
c1	45 (typ.)					
D	4.8		5.0	0.188		0.196
E	5.8		6.2	0.228		0.244
e		1.27			0.050	
e3		3.81			0.150	
F	3.8		4.0	0.14		0.157
L	0.4		1.27	0.015		0.050
M			0.6			0.023
S	8 (max.)					

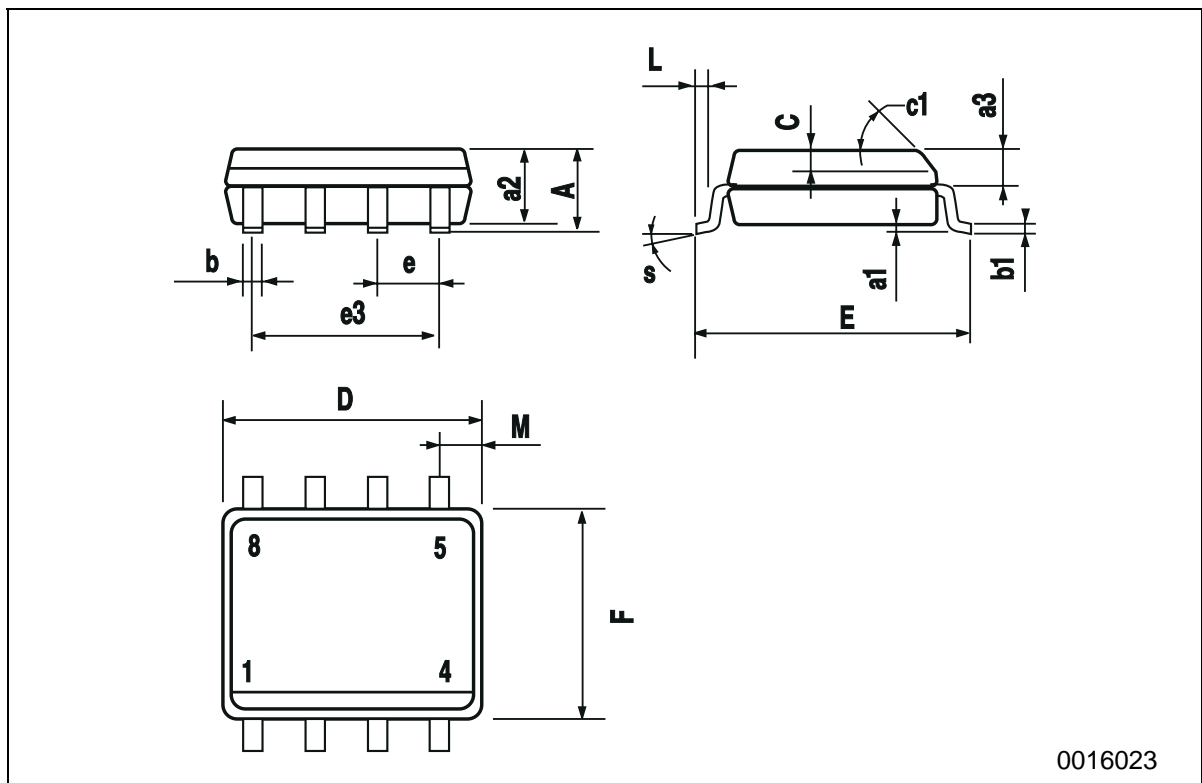

Information furnished is believed to be accurate and reliable. However, STMicroelectronics assumes no responsibility for the consequences of use of such information nor for any infringement of patents or other rights of third parties which may result from its use. No license is granted by implication or otherwise under any patent or patent rights of STMicroelectronics. Specifications mentioned in this publication are subject to change without notice. This publication supersedes and replaces all information previously supplied. STMicroelectronics products are not authorized for use as critical components in life support devices or systems without express written approval of STMicroelectronics.

© The ST logo is a registered trademark of STMicroelectronics

© 2000 STMicroelectronics - Printed in Italy - All Rights Reserved  
STMicroelectronics GROUP OF COMPANIES

Australia - Brazil - China - Finland - France - Germany - Hong Kong - India - Italy - Japan - Malaysia - Malta - Morocco  
Singapore - Spain - Sweden - Switzerland - United Kingdom

© <http://www.st.com>

## Looking for pricing, stock, or lifecycle information?

Click below to explore more details on WIN SOURCE:

- ⊖ [View ST763ACDTR](#) on WIN SOURCE
- ⊖ [STMicroelectronics](#) Information

## Optimize Your Supply Chain with WIN SOURCE Solutions

- ✓ Global Sourcing Solution
- ✓ Obsolete Management
- ✓ Cost Control Management
- ✓ Shortage Management
- ✓ Alternative Solution
- ✓ Excess Inventory Management