



THE DATASHEET OF STD10P6F6



P-channel -60 V, 0.13 Ω typ., -10 A STripFET™ F6
Power MOSFETs in DPAK, TO-220FP, TO-220 and IPAK packages

Datasheet – production data

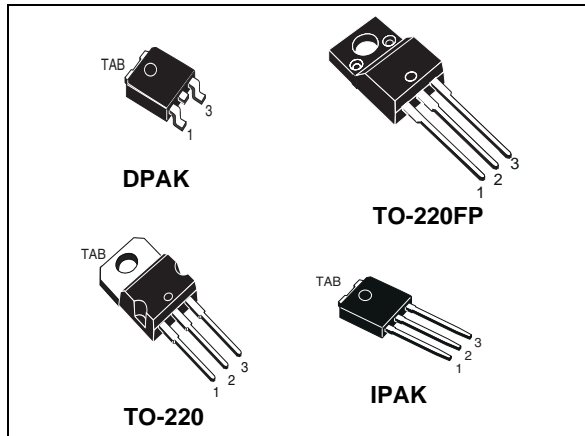
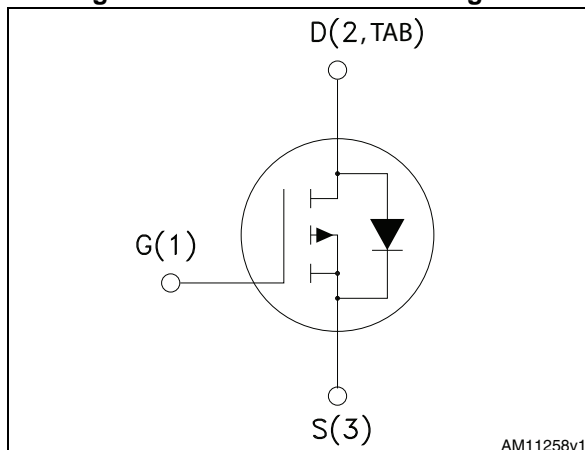

Figure 1. Internal schematic diagram



Features

Order codes	V_{DS}	$R_{DS(on)}$ max	I_D
STD10P6F6	-60 V	0.16 Ω	-10 A
STF10P6F6			
STP10P6F6			
STU10P6F6			

- Very low on-resistance
- Very low gate charge
- High avalanche ruggedness
- Low gate drive power loss

Applications

- Switching applications

Description

These devices are P-channel Power MOSFETs developed using the STripFET™ F6 technology, with a new trench gate structure. The resulting Power MOSFETs exhibit very low $R_{DS(on)}$ in all packages.

Table 1. Device summary

Order codes	Marking	Package	Packing
STD10P6F6	10P6F6	DPAK	Tape and reel
STF10P6F6		TO-220FP	Tube
STP10P6F6		TO-220	
STU10P6F6		IPAK	

Contents

1	Electrical ratings	3
2	Electrical characteristics	4
	2.1 Electrical characteristics (curves)	6
3	Test circuits	9
4	Package information	10
	4.1 DPAK package information	10
	4.2 DPAK packing information	13
	4.3 TO-220FP package information	15
	4.4 TO-220 package information	17
	4.5 IPAK package information	19
5	Revision history	23

1 Electrical ratings

Table 2. Absolute maximum ratings

Symbol	Parameter	Value			Unit
		DPAK IPAK	TO-220FP	TO-220	
V_{DS}	Drain-source voltage	-60			V
V_{GS}	Gate-source voltage	± 20			V
$I_D^{(1)}$	Drain current (continuous) at $T_C = 25\text{ °C}$	-10			A
I_D	Drain current (continuous) at $T_C = 100\text{ °C}$	-7.2			A
$I_{DM}^{(2)}$	Drain current (pulsed)	-40			A
P_{TOT}	Total dissipation at $T_C = 25\text{ °C}$	35	20	30	W
E_{AS}	Single pulse avalanche energy (starting $T_J=25\text{ °C}$, $I_D=-3\text{ A}$, $V_{DD}=40\text{ V}$)	80			mJ
V_{ISO}	Insulation withstand voltage (RMS) from all three leads to external heat sink ($t=1\text{ s}$; $T_C=25\text{ °C}$)		2500		V
V_{DG}	Drain-gate voltage ($V_{GS} = 0$)	-20			V
T_{stg}	Storage temperature	-55 to 175			°C
T_j	Max. operating junction temperature	175			°C

1. Limited by package
2. Pulse width limited by safe operating area

Table 3. Thermal data

Symbol	Parameter	Value				Unit
		DPAK	IPAK	TO-220FP	TO-220	
$R_{thj-case}$	Thermal resistance junction-case max	4.29		7.5	5	°C/W
$R_{thj-amb}$	Thermal resistance junction-ambient max		100	62.5	62.5	°C/W
$R_{thj-pcb}$	Thermal resistance junction-pcb max ⁽¹⁾	50				°C/W

1. When mounted on 1 inch² FR-4, 2 Oz copper board

2 Electrical characteristics

($T_{CASE} = 25\text{ °C}$ unless otherwise specified).

Table 4. Static

Symbol	Parameter	Test conditions	Min.	Typ.	Max.	Unit
$V_{(BR)DSS}$	Drain-source breakdown Voltage	$I_D = -250\ \mu\text{A}$, $V_{GS} = 0\ \text{V}$	-60			V
I_{DSS}	Zero gate voltage drain current ($V_{GS} = 0$)	$V_{DS} = -60\ \text{V}$			-1	μA
		$V_{DS} = -60\ \text{V}$, $T_c = 125\text{ °C}$			-10	μA
I_{GSS}	Gate body leakage current ($V_{DS} = 0$)	$V_{GS} = \pm 20\ \text{V}$			± 100	nA
$V_{GS(th)}$	Gate threshold voltage	$V_{DS} = V_{GS}$, $I_D = -250\ \mu\text{A}$	-2		-4	V
$R_{DS(on)}$	Static drain-source on-resistance	$V_{GS} = -10\ \text{V}$, $I_D = -5\ \text{A}$		0.13	0.16	Ω

Table 5. Dynamic

Symbol	Parameter	Test conditions	Min.	Typ.	Max.	Unit
C_{iss}	Input capacitance	$V_{DS} = -48\ \text{V}$, $f = 1\ \text{MHz}$, $V_{GS} = 0\ \text{V}$	-	340	-	pF
C_{oss}	Output capacitance		-	40	-	pF
C_{rss}	Reverse transfer capacitance		-	20	-	pF
Q_g	Total gate charge	$V_{DD} = -30\ \text{V}$, $I_D = -10\ \text{A}$	-	6.4	-	nC
Q_{gs}	Gate-source charge	$V_{GS} = -10\ \text{V}$	-	1.7	-	nC
Q_{gd}	Gate-drain charge	(see Figure 16)	-	1.7	-	nC

Table 6. Switching on/off (inductive load)

Symbol	Parameter	Test conditions	Min.	Typ.	Max.	Unit
$t_{d(on)}$	Turn-on delay time	$V_{DD} = -48\ \text{V}$, $I_D = -5\ \text{A}$, $R_G = 4.7\ \Omega$, $V_{GS} = -10\ \text{V}$ (see Figure 15)	-	64	-	ns
t_r	Rise time		-	5.3	-	ns
$t_{d(off)}$	Turn-off delay time		-	14	-	ns
t_f	Fall time		-	3.7	-	ns

Table 7. Source drain diode

Symbol	Parameter	Test conditions	Min.	Typ.	Max.	Unit
I_{SD}	Source-drain current		-		-10	A
$I_{SDM}^{(1)}$	Source-drain current (pulsed)		-		-40	A
$V_{SD}^{(2)}$	Forward on voltage	$I_{SD} = -5\text{ A}$, $V_{GS} = 0\text{ V}$	-		-1.1	V
t_{rr}	Reverse recovery time	$I_{SD} = -10\text{ A}$, $di/dt = -100\text{ A}/\mu\text{s}$, $V_{DD} = -48\text{ V}$ (see Figure 17)	-	20		ns
Q_{rr}	Reverse recovery charge		-	17.8		nC
I_{RRM}	Reverse recovery current		-	-1.8		A

1. Pulse width limited by safe operating area.
2. Pulsed: pulse duration = 300 μs , duty cycle 1.5%

2.1 Electrical characteristics (curves)

Note: For the P-channel Power MOSFET, current and voltage polarities are reversed.

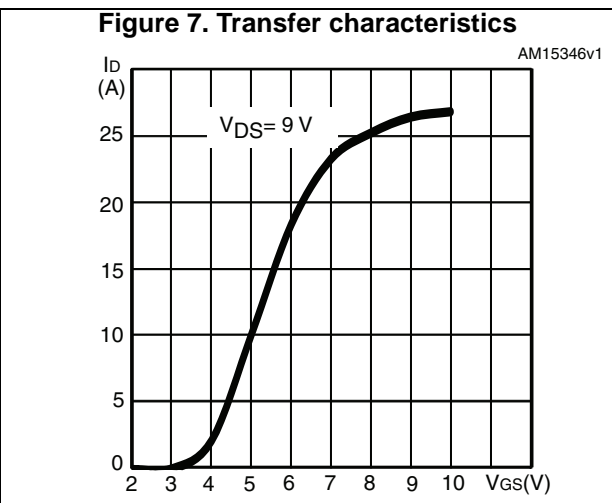
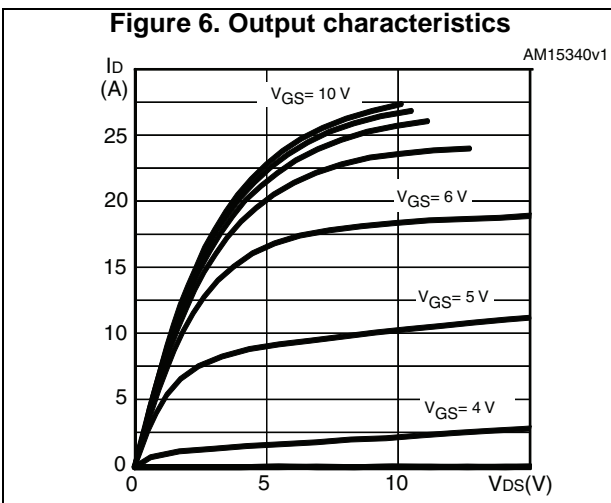
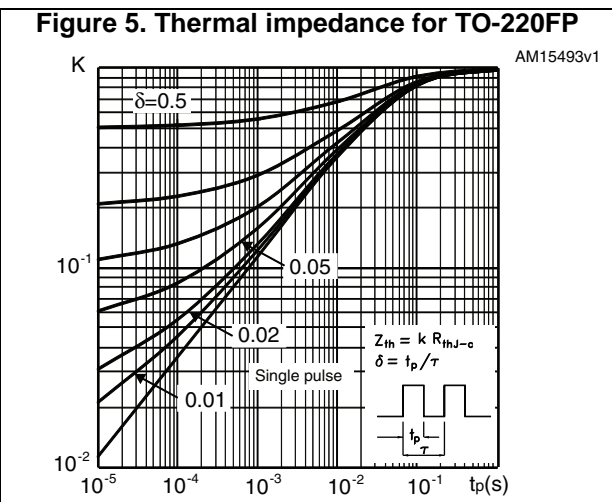
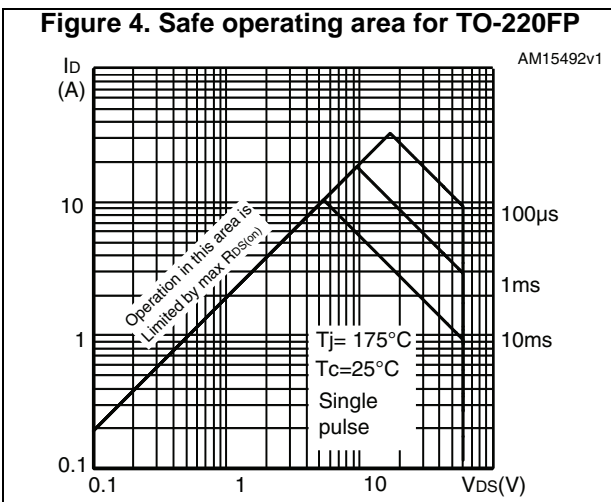
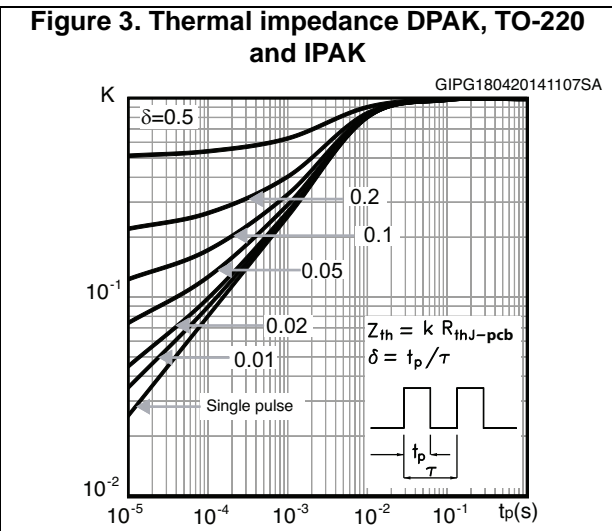
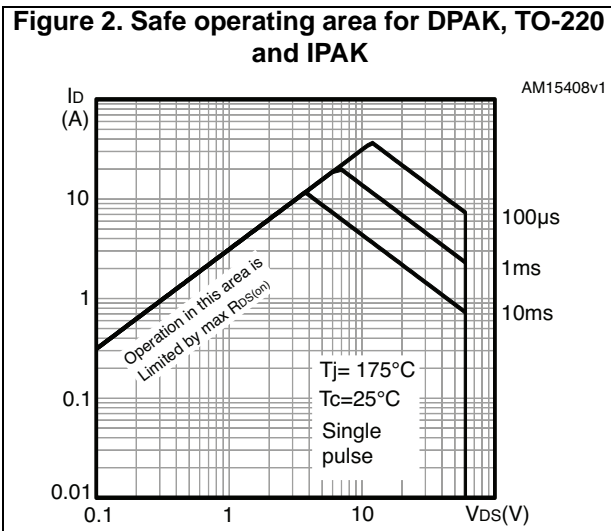

Figure 8. Gate charge vs gate-source voltage

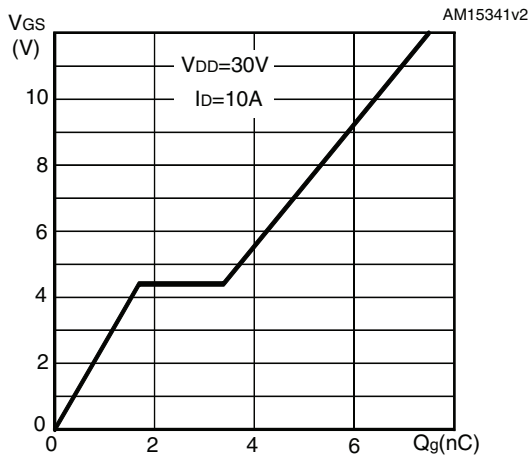

Figure 9. Static drain-source on-resistance

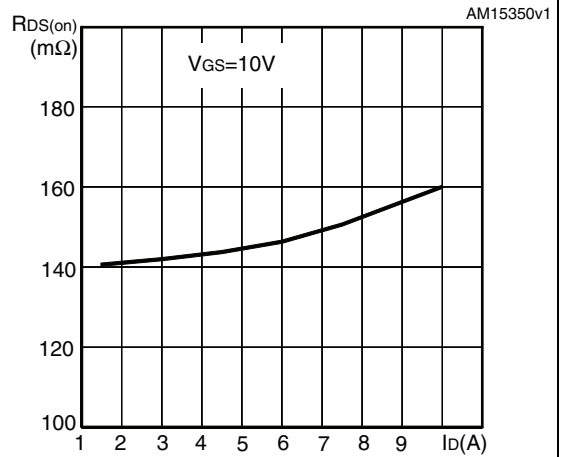

Figure 10. Capacitance variations

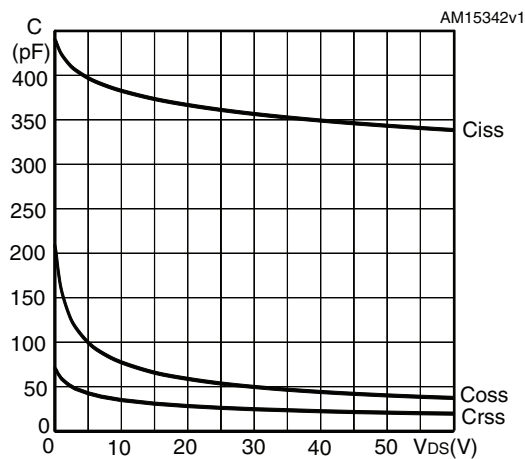

Figure 11. Normalized $V_{(BR)DSS}$ vs temperature

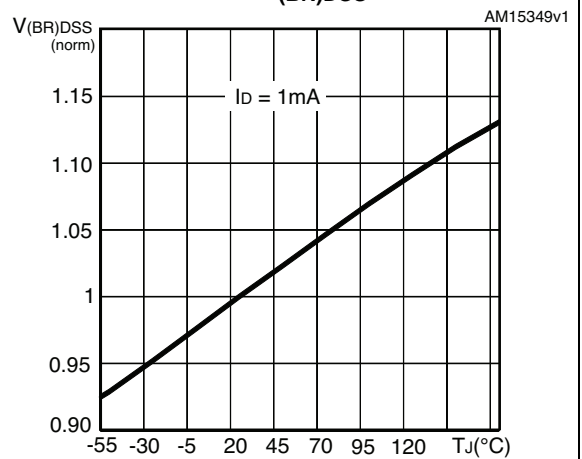

Figure 12. Normalized gate threshold voltage vs temperature

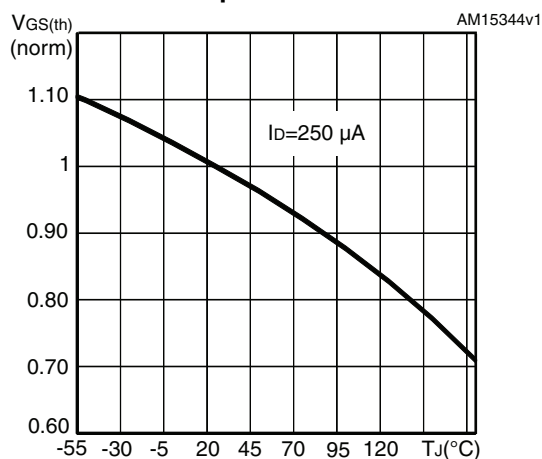
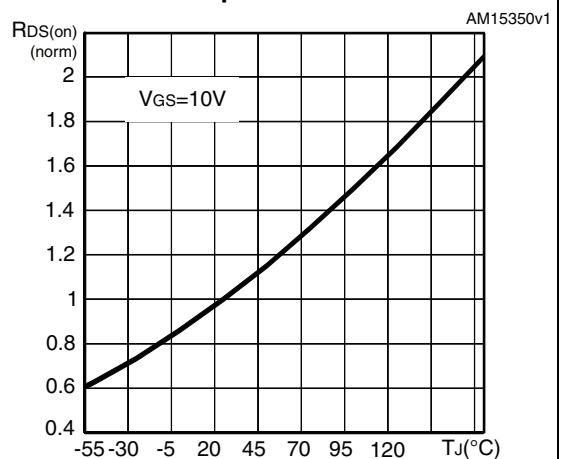
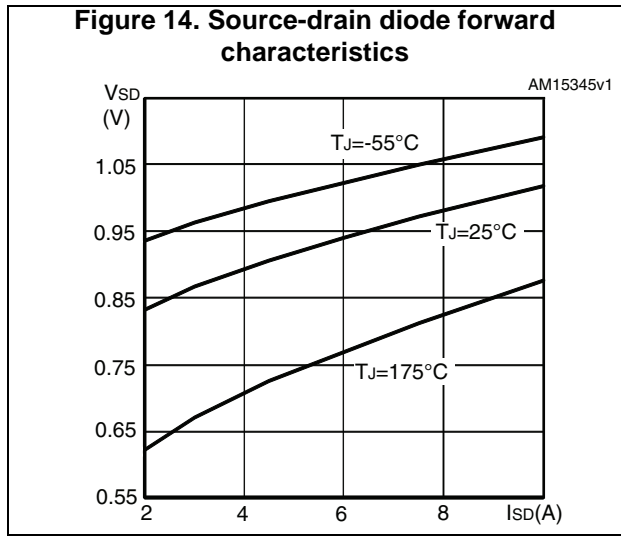

Figure 13. Normalized on-resistance vs temperature





3 Test circuits

Figure 15. Switching times test circuit for resistive load

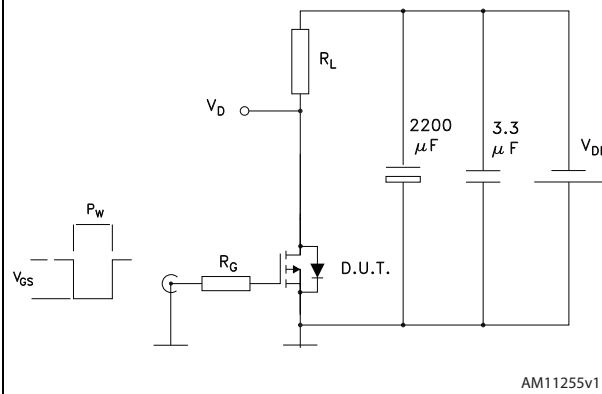

Figure 16. Gate charge test circuit

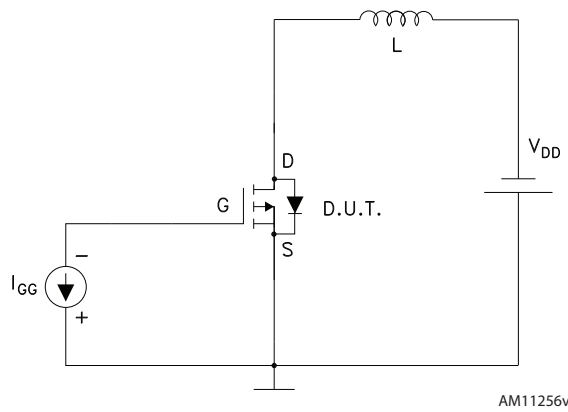
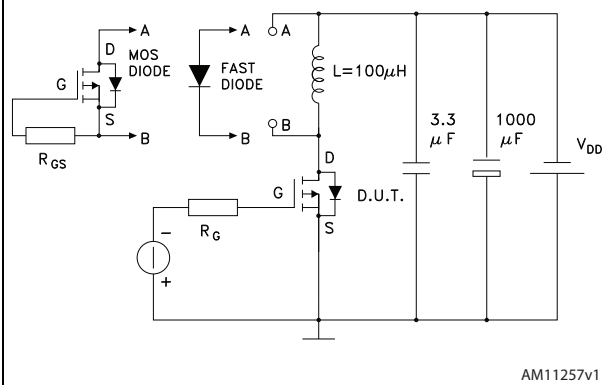

Figure 17. Test circuit for diode recovery behaviour



4 Package information

In order to meet environmental requirements, ST offers these devices in different grades of ECOPACK® packages, depending on their level of environmental compliance. ECOPACK® specifications, grade definitions and product status are available at: www.st.com. ECOPACK® is an ST trademark.

4.1 DPAK package information

Figure 18. DPAK (TO-252) type C package outline

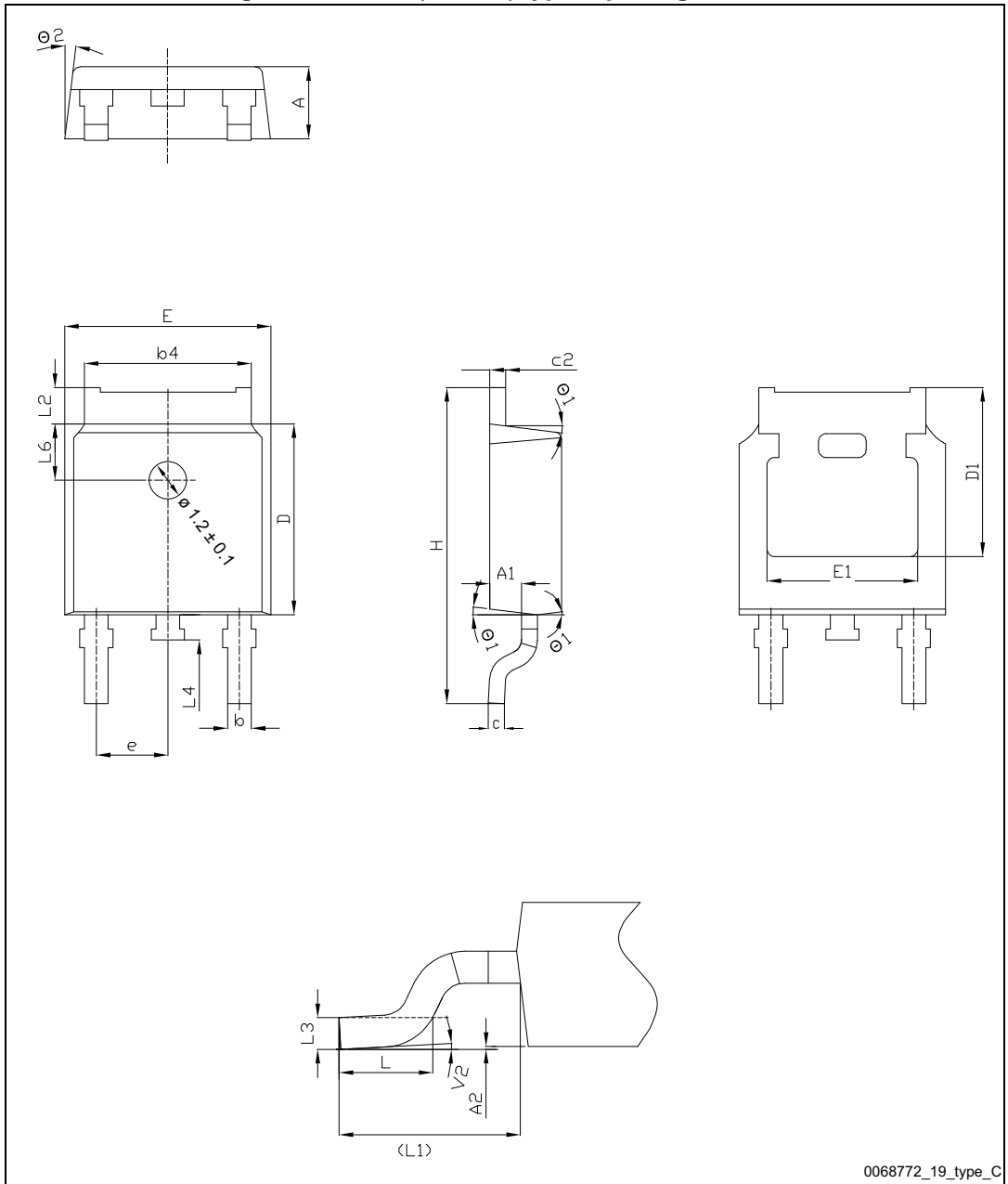
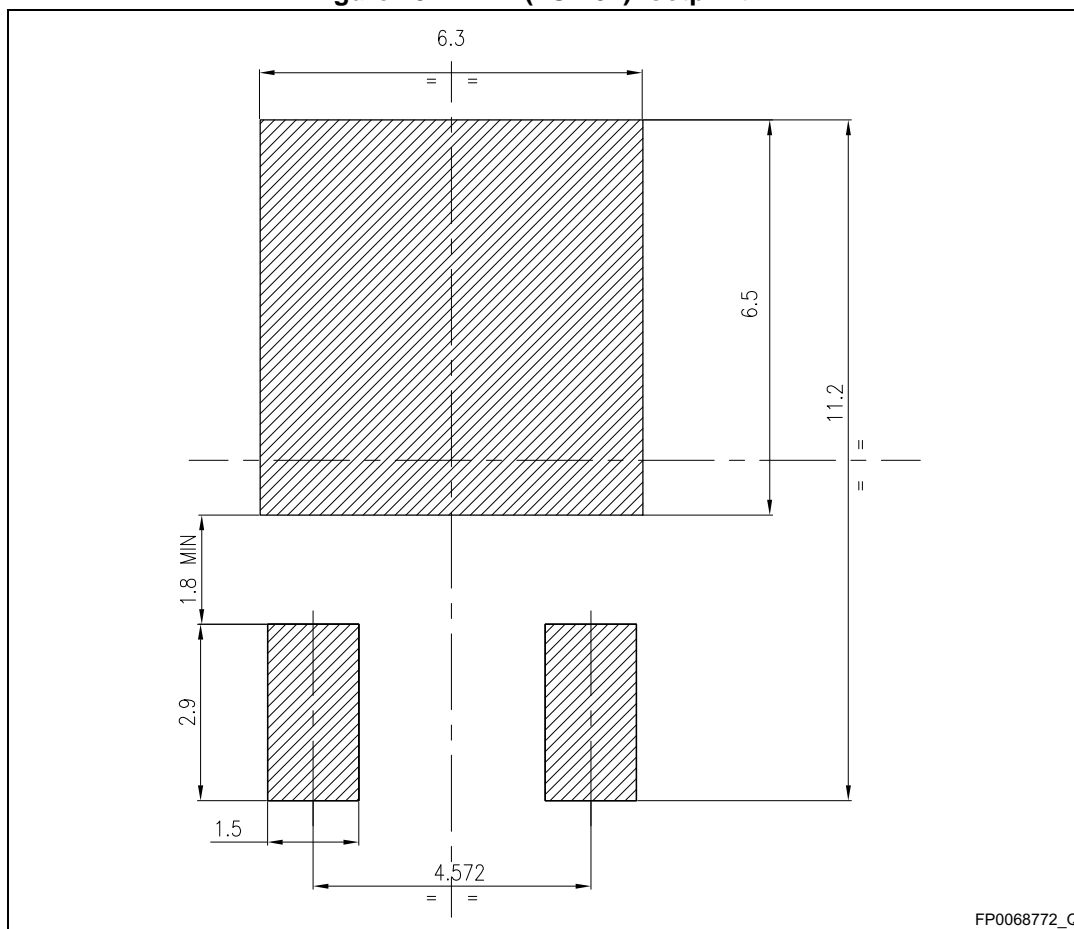

Table 8. DPAK (TO-252) type C package mechanical data

Dim.	mm		
	Min.	Typ.	Max.
A	2.20	2.30	2.38
A1	0.90	1.01	1.10
A2	0.00		0.10
b	0.72		0.85
b4	5.13	5.33	5.46
c	0.47		0.60
c2	0.47		0.60
D	6.00	6.10	6.20
D1	5.25		
E	6.50	6.60	6.70
e	2.186	2.286	2.386
E1	4.70		
H	9.80	10.10	10.40
L	1.40	1.50	1.70
L1	2.90 REF		
L2	0.90		1.25
L3	0.51 BSC		
L4	0.60	0.80	1.00
L6	1.80 BSC		
θ1	5°	7°	9°
θ2	5°	7°	9°
V2	0°		8°

Figure 19. DPAK (TO-252) footprint (a)



a. All dimensions are in millimeters

4.2 DPAK packing information

Figure 20. Tape for DPAK (TO-252)

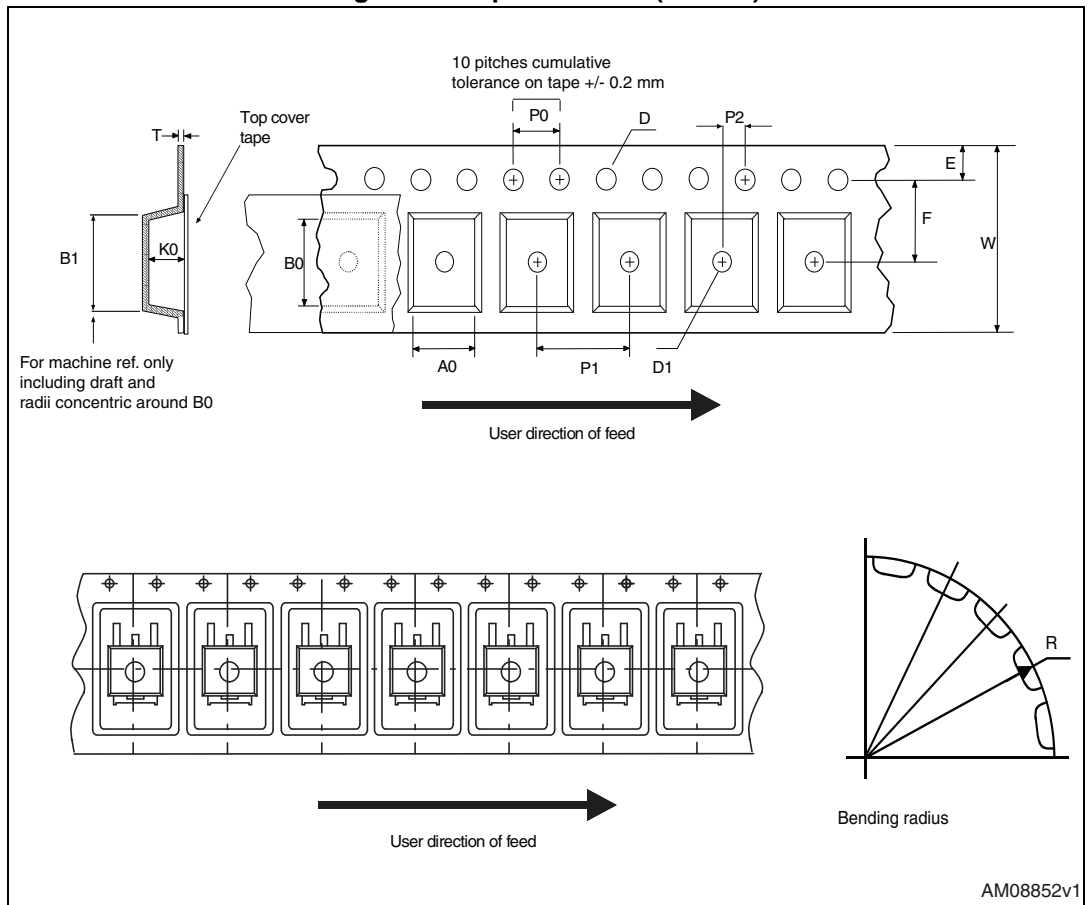

Figure 21. Reel for DPAK (TO-252)

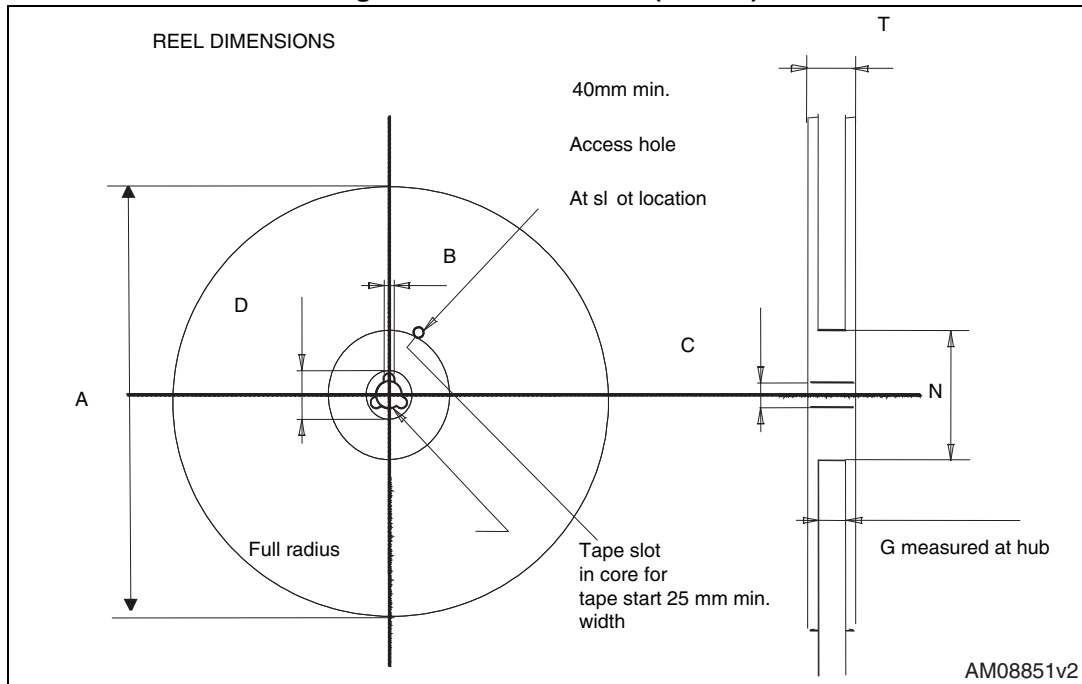
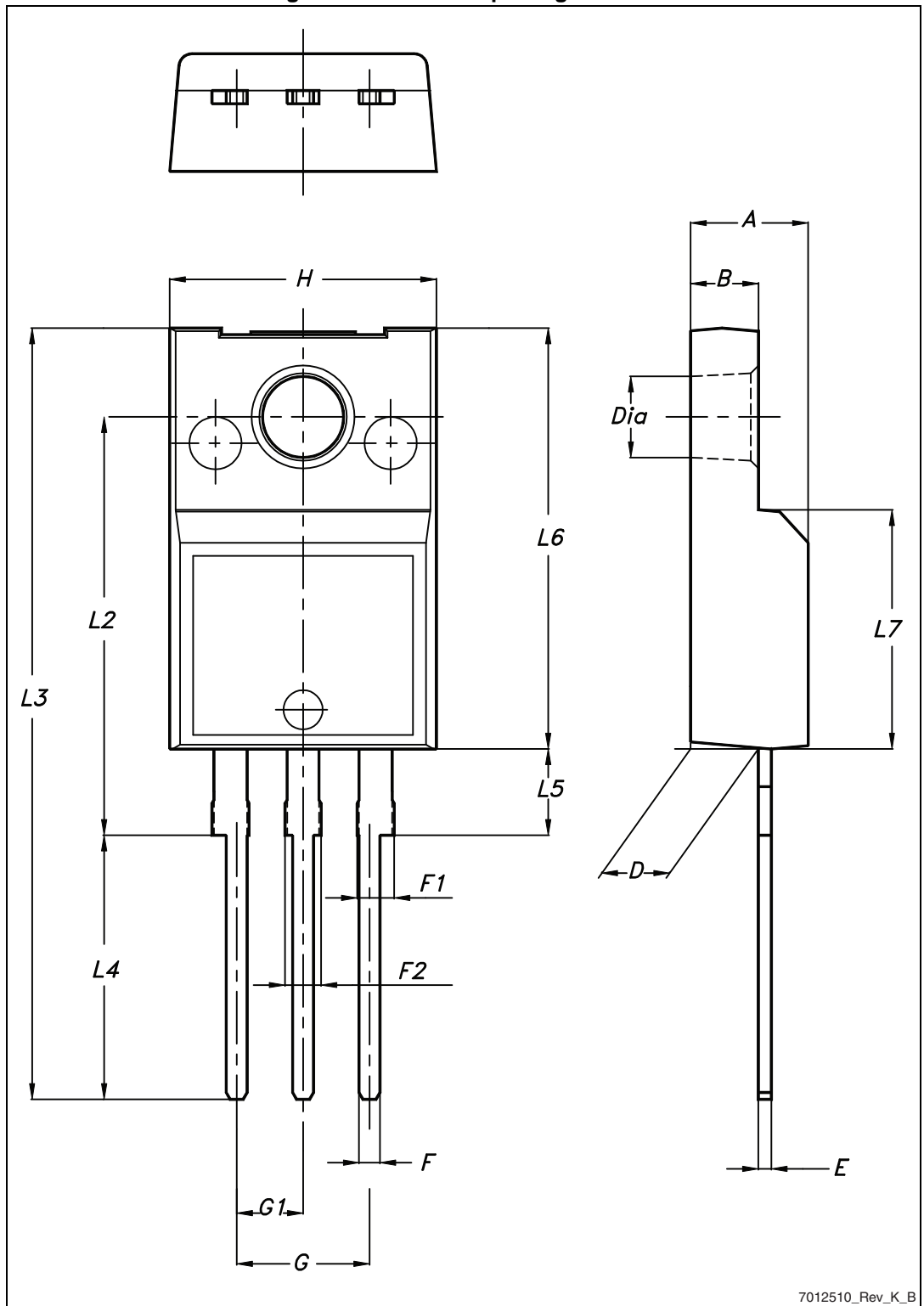

Table 9. DPAK (TO-252) tape and reel mechanical data

Tape			Reel		
Dim.	mm		Dim.	mm	
	Min.	Max.		Min.	Max.
A0	6.8	7	A		330
B0	10.4	10.6	B	1.5	
B1		12.1	C	12.8	13.2
D	1.5	1.6	D	20.2	
D1	1.5		G	16.4	18.4
E	1.65	1.85	N	50	
F	7.4	7.6	T		22.4
K0	2.55	2.75			
P0	3.9	4.1		Base qty.	2500
P1	7.9	8.1		Bulk qty.	2500
P2	1.9	2.1			
R	40				
T	0.25	0.35			
W	15.7	16.3			

4.3 TO-220FP package information

Figure 22. TO-220FP package outline



7012510_Rev_K_B

Table 10. TO-220FP mechanical data

Dim.	mm		
	Min.	Typ.	Max.
A	4.4		4.6
B	2.5		2.7
D	2.5		2.75
E	0.45		0.7
F	0.75		1
F1	1.15		1.70
F2	1.15		1.70
G	4.95		5.2
G1	2.4		2.7
H	10		10.4
L2		16	
L3	28.6		30.6
L4	9.8		10.6
L5	2.9		3.6
L6	15.9		16.4
L7	9		9.3
Dia	3		3.2

4.4 TO-220 package information

Figure 23. TO-220 type A package outline

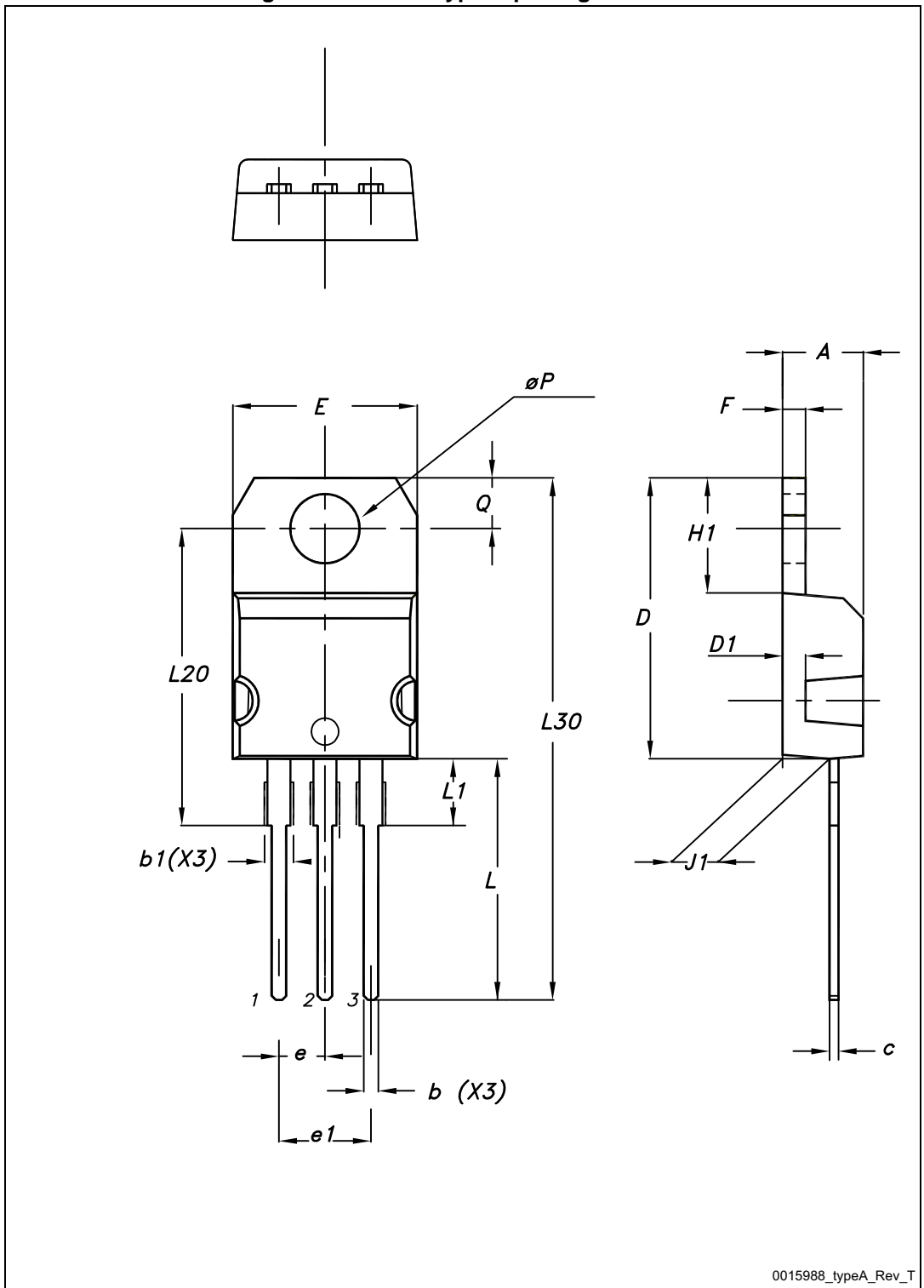

Table 11. TO-220 type A mechanical data

Dim.	mm		
	Min.	Typ.	Max.
A	4.40		4.60
b	0.61		0.88
b1	1.14		1.70
c	0.48		0.70
D	15.25		15.75
D1		1.27	
E	10		10.40
e	2.40		2.70
e1	4.95		5.15
F	1.23		1.32
H1	6.20		6.60
J1	2.40		2.72
L	13		14
L1	3.50		3.93
L20		16.40	
L30		28.90	
ØP	3.75		3.85
Q	2.65		2.95

4.5 IPAK package information

Figure 24. IPAK (TO-251) type A package outline

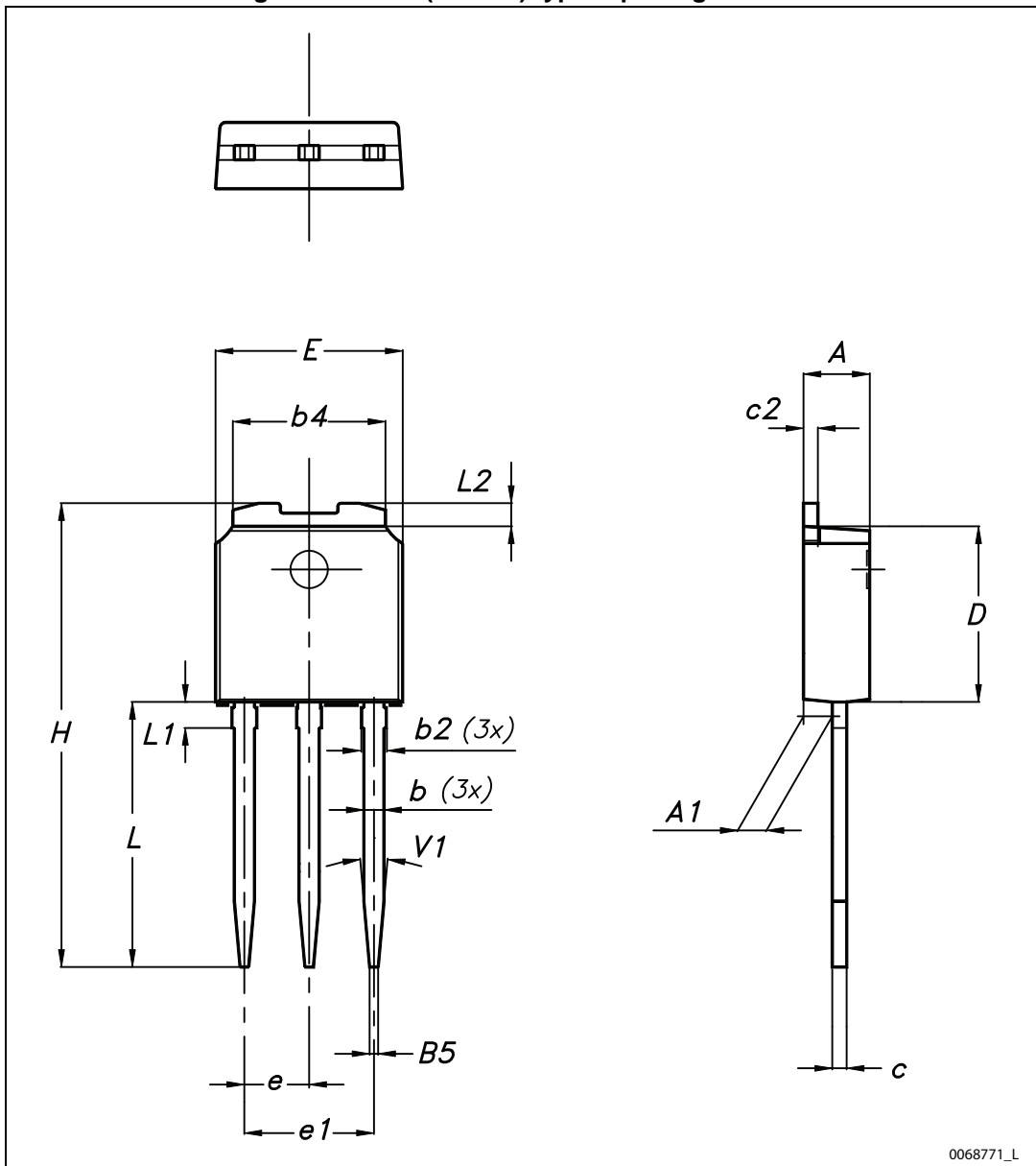
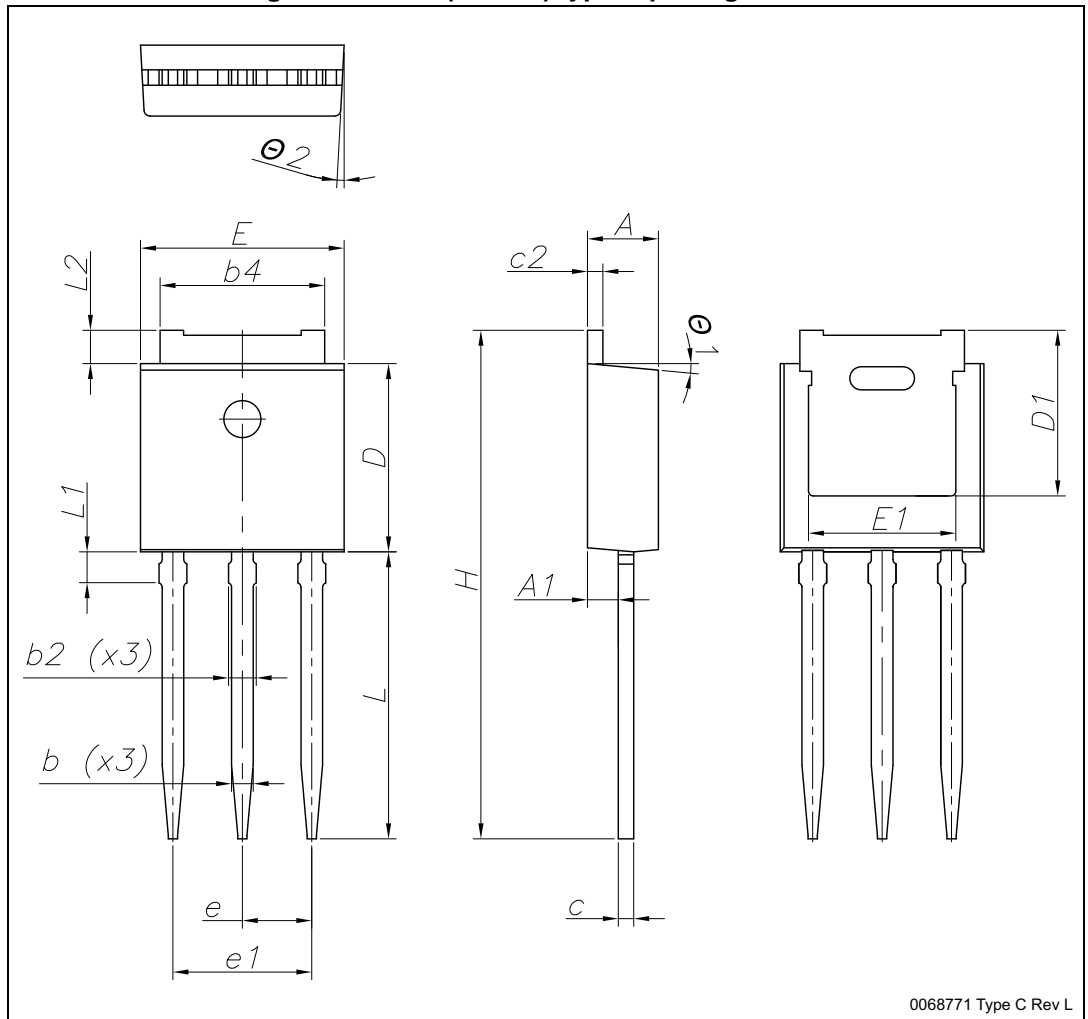

Table 12. IPAK (TO-251) type A mechanical data

DIM	mm.		
	min.	typ.	max.
A	2.20		2.40
A1	0.90		1.10
b	0.64		0.90
b2			0.95
b4	5.20		5.40
B5		0.30	
c	0.45		0.60
c2	0.48		0.60
D	6.00		6.20
E	6.40		6.60
e		2.28	
e1	4.40		4.60
H		16.10	
L	9.00		9.40
L1	0.80		1.20
L2		0.80	1.00
V1		10°	

Figure 25. IPAK (TO-251) type C package outline



0068771 Type C Rev L

Table 13. IPAK (TO-251) type C mechanical data

Dim.	mm		
	min.	typ.	max.
A	2.20	2.30	2.35
A1	0.90	1.00	1.10
b	0.66		0.79
b2			0.90
b4	5.23	5.33	5.43
c	0.46		0.59
c2	0.46		0.59
D	6.00	6.10	6.20
D1	5.20	5.37	5.55
E	6.50	6.60	6.70
E1	4.60	4.78	4.95
e	2.20	2.25	2.30
e1	4.40	4.50	4.60
H	16.18	16.48	16.78
L	9.00	9.30	9.60
L1	0.80	1.00	1.20
L2	0.90	1.08	1.25
θ1	3°	5°	7°
θ2	1°	3°	5°

5 Revision history

Table 14. Document revision history

Date	Revision	Changes
10-May-2012	1	First release.
20-Jun-2012	2	Updated title on the cover page. Updated all parameter values in Table 5 , Table 6 and Figure 1 .
17-May-2013	3	<ul style="list-style-type: none"> – Added: TO-220FP and IPAK packages – Updated: $R_{DS(on)}$ value in cover page, $R_{thj-case}$ values, Table 5, 6 and 7 typical values – Updated mechanical data only for DPAK in Section 4: Package information
24-Apr-2014	4	<ul style="list-style-type: none"> – Updated: Figure 2 and 3 – Updated: Section 4.1: DPAK package information and Section 4.4: TO-220 package information – Minor text changes
27-Jul-2015	5	<ul style="list-style-type: none"> – All voltage and current polarities inverted – Added: note in Section 2.1: Electrical characteristics (curves) – Updated: Section 4.1 and Section 4.5 – Text and formatting changes throughout document

IMPORTANT NOTICE – PLEASE READ CAREFULLY

STMicroelectronics NV and its subsidiaries ("ST") reserve the right to make changes, corrections, enhancements, modifications, and improvements to ST products and/or to this document at any time without notice. Purchasers should obtain the latest relevant information on ST products before placing orders. ST products are sold pursuant to ST's terms and conditions of sale in place at the time of order acknowledgement.

Purchasers are solely responsible for the choice, selection, and use of ST products and ST assumes no liability for application assistance or the design of Purchasers' products.

No license, express or implied, to any intellectual property right is granted by ST herein.

Resale of ST products with provisions different from the information set forth herein shall void any warranty granted by ST for such product.



ST and the ST logo are trademarks of ST. All other product or service names are the property of their respective owners.

Information in this document supersedes and replaces information previously supplied in any prior versions of this document.

© 2015 STMicroelectronics – All rights reserved

Looking for pricing, stock, or lifecycle information?

Click below to explore more details on WIN SOURCE:

-  [View STD10P6F6 on WIN SOURCE](#)
-  [STMicroelectronics Information](#)

Optimize Your Supply Chain with WIN SOURCE Solutions

-  Global Sourcing Solution
-  Obsolete Management
-  Cost Control Management
-  Shortage Management
-  Alternative Solution
-  Excess Inventory Management