



# THE DATASHEET OF STD1NK60-1



## N-channel 600 V, 7.3 $\Omega$ typ., 0.4 A SuperMESH™ Power MOSFETs in a SOT-223 and TO-92 packages



SOT-223

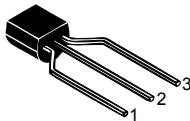

TO-92 (Ammopack)

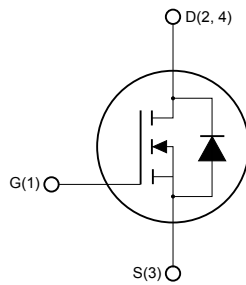

Int\_schem\_nTnZ\_SOT\_223

### Features

Order code	$V_{DS}$	$R_{DS(on)}$ max.	$I_D$	Package
STN1HNK60	600 V	8.5 $\Omega$	0.4 A	SOT-223
STQ1HNK60R-AP				TO-92

- Extremely high dv/dt capability
- 100% avalanche tested
- Gate charge minimized

### Applications

- Switching applications

### Description

These high-voltage devices are Zener-protected N-channel Power MOSFETs developed using the SuperMESH™ technology by STMicroelectronics, an optimization of the well-established PowerMESH™. In addition to a significant reduction in on-resistance, these devices are designed to ensure a high level of dv/dt capability for the most demanding applications.

#### Product status

STN1HNK60

STQ1HNK60R-AP

# 1 Electrical ratings

**Table 1. Absolute maximum ratings**

Symbol	Parameter	Value		Unit
		SOT-223	TO-92	
$V_{DS}$	Drain-source voltage	600		V
$V_{DGR}$	Drain-gate voltage ( $R_{GS} = 20 \text{ k}\Omega$ )	600		V
$V_{GS}$	Gate- source voltage	$\pm 30$		V
$I_D$	Drain current (continuous) at $T_C = 25 \text{ }^\circ\text{C}$	0.4		A
$I_D$	Drain current (continuous) at $T_C = 100 \text{ }^\circ\text{C}$	0.25		A
$I_{DM}^{(1)}$	Drain current (pulsed)	1.6		A
$P_{TOT}$	Total dissipation at $T_C = 25 \text{ }^\circ\text{C}$	3.3	3	W
$dv/dt^{(2)}$	Peak diode recovery voltage slope	3		V/ns
$T_j$	Operating junction temperature range	-55 to 150		$^\circ\text{C}$
$T_{stg}$	Storage temperature range			

1. Pulse width limited by safe operating area.
2.  $I_{SD} \leq 0.4 \text{ A}$ ,  $di/dt \leq 100 \text{ A}/\mu\text{s}$ ,  $V_{DD} \leq V_{(BR)DSS}$ .

**Table 2. Thermal data**

Symbol	Parameter	Value		Unit
		SOT-223	TO-92	
$R_{thj-amb}$	Thermal resistance junction-ambient		120	$^\circ\text{C}/\text{W}$
$R_{thj-lead}$	Thermal resistance junction-lead		40	$^\circ\text{C}/\text{W}$
$R_{thj-pcb}^{(1)}$	Thermal resistance junction-pcb	37.87		$^\circ\text{C}/\text{W}$

1. When mounted on FR-4 board of  $1 \text{ in}^2$ , 2 oz Cu,  $t < 10 \text{ s}$ .

**Table 3. Avalanche characteristics**

Symbol	Parameter	Value	Unit
$I_{AR}$	Avalanche current, repetitive or not-repetitive (pulse width limited by $T_j \text{ Max}$ )	0.4	A
$E_{AS}$	Single pulse avalanche energy (starting $T_j = 25 \text{ }^\circ\text{C}$ , $I_D = I_{AR}$ , $V_{DD} = 50 \text{ V}$ )	25	mJ

## 2 Electrical characteristics

( $T_{CASE} = 25\text{ °C}$  unless otherwise specified)

**Table 4. On/off states**

Symbol	Parameter	Test conditions	Min.	Typ.	Max.	Unit
$V_{(BR)DSS}$	Drain-source breakdown voltage	$I_D = 1\text{ mA}$ , $V_{GS} = 0\text{ V}$	600			V
$I_{DSS}$	Zero gate voltage drain current	$V_{GS} = 0\text{ V}$ , $V_{DS} = 600\text{ V}$			1	$\mu\text{A}$
		$V_{GS} = 0\text{ V}$ , $V_{DS} = 600\text{ V}$ , $T_C = 125\text{ °C}$ <sup>(1)</sup>			50	$\mu\text{A}$
$I_{GSS}$	Gate body leakage current	$V_{DS} = 0\text{ V}$ , $V_{GS} = \pm 30\text{ V}$			$\pm 100$	nA
$V_{GS(th)}$	Gate threshold voltage	$V_{DS} = V_{GS}$ , $I_D = 250\text{ }\mu\text{A}$	2.25	3	3.7	V
$R_{DS(on)}$	Static drain-source on resistance	$V_{GS} = 10\text{ V}$ , $I_D = 0.5\text{ A}$		7.3	8.5	$\Omega$

1. Defined by design, not subject to production test.

**Table 5. Dynamic**

Symbol	Parameter	Test conditions	Min.	Typ.	Max.	Unit
$C_{iss}$	Input capacitance	$V_{DS} = 25\text{ V}$ , $f = 1\text{ MHz}$ , $V_{GS} = 0\text{ V}$	-	156		$\mu\text{F}$
$C_{oss}$	Output capacitance			23.5		
$C_{rss}$	Reverse transfer capacitance			3.8		
$Q_g$	Total gate charge	$V_{DD} = 480\text{ V}$ , $I_D = 1\text{ A}$ , $V_{GS} = 0\text{ to }10\text{ V}$ (see Figure 16. Test circuit for gate charge behavior)	-	7	10	nC
$Q_{gs}$	Gate-source charge			1.1		
$Q_{gd}$	Gate-drain charge			3.7		

**Table 6. Switching times**

Symbol	Parameter	Test conditions	Min.	Typ.	Max.	Unit
$t_{d(on)}$	Turn-on delay time	$V_{DD} = 300\text{ V}$ , $I_D = 0.5\text{ A}$ , $R_G = 4.7\text{ }\Omega$ , $V_{GS} = 10\text{ V}$	-	6.5	-	ns
$t_r$	Rise time			5		
$t_{d(off)}$	Turn-off delay time	(see Figure 15. Test circuit for resistive load switching times and Figure 20. Switching time waveform)	-	19	-	ns
$t_f$	Fall time			25		

**Table 7. Source drain diode**

Symbol	Parameter	Test conditions	Min.	Typ.	Max.	Unit
$I_{SD}$	Source-drain current				0.4	A
$I_{SDM}^{(1)}$	Source-drain current (pulsed)		-		1.6	
$V_{SD}^{(2)}$	Forward on voltage	$I_{SD} = 0.4 \text{ A}$ , $V_{GS} = 0 \text{ V}$	-		1.6	V
$t_{rr}$	Reverse recovery time	$I_{SD} = 1.0 \text{ A}$ , $di/dt = 100 \text{ A}/\mu\text{s}$		140		ns
$Q_{rr}$	Reverse recovery charge	$V_{DD} = 25 \text{ V}$ (see <a href="#">Figure 17. Test circuit for inductive load switching and diode recovery times</a> )	-	240		nC
$I_{RRM}$	Reverse recovery current			3.3		A
$t_{rr}$	Reverse recovery time	$I_{SD} = 1.0 \text{ A}$ , $di/dt = 100 \text{ A}/\mu\text{s}$		229		ns
$Q_{rr}$	Reverse recovery charge	$V_{DD} = 25 \text{ V}$ , $T_J = 150 \text{ }^\circ\text{C}$ (see <a href="#">Figure 17. Test circuit for inductive load switching and diode recovery times</a> )	-	377		nC
$I_{RRM}$	Reverse recovery current			3.3		A

1. Pulse width limited by safe operating area.

2. Pulsed: pulse duration = 300  $\mu\text{s}$ , duty cycle 1.5%.

## 2.1 Electrical characteristics curves

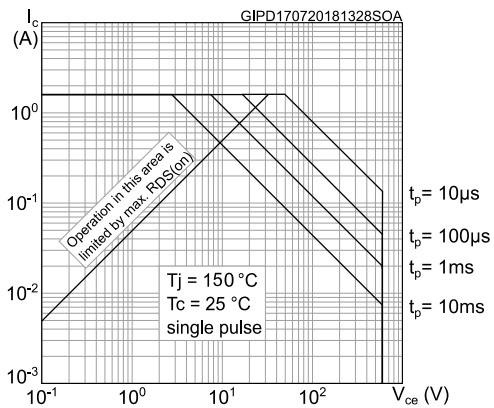
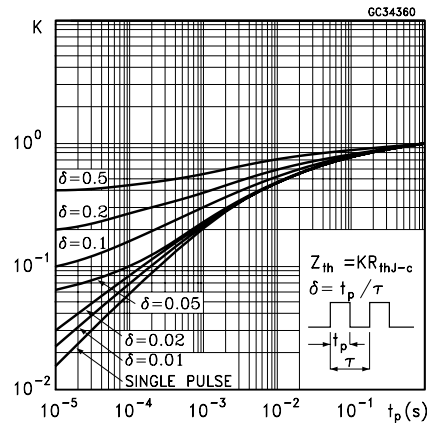
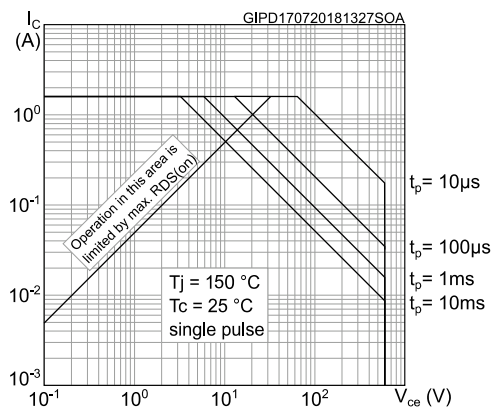
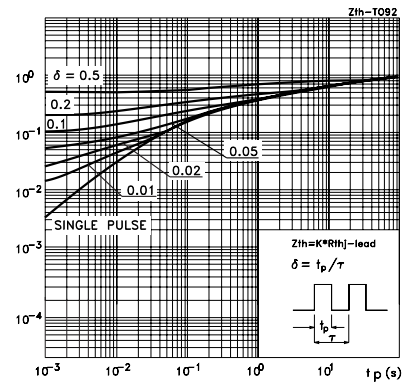
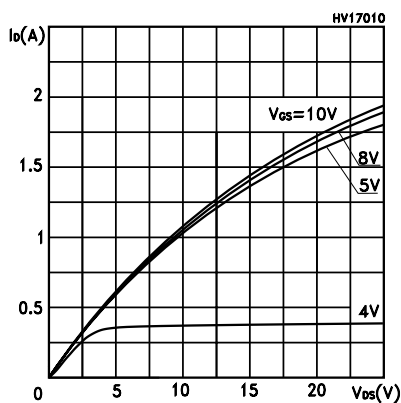
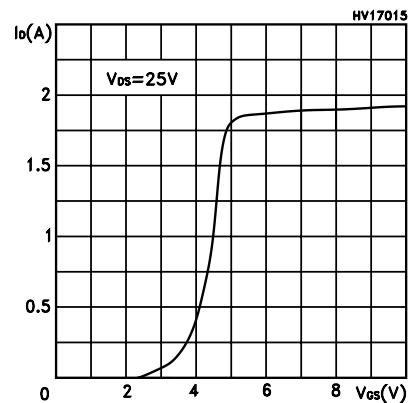
**Figure 1. Safe operating area for SOT-223**

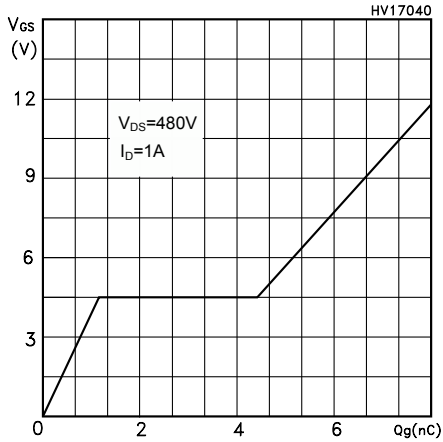
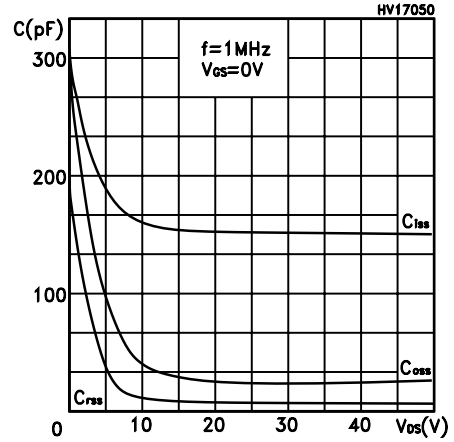
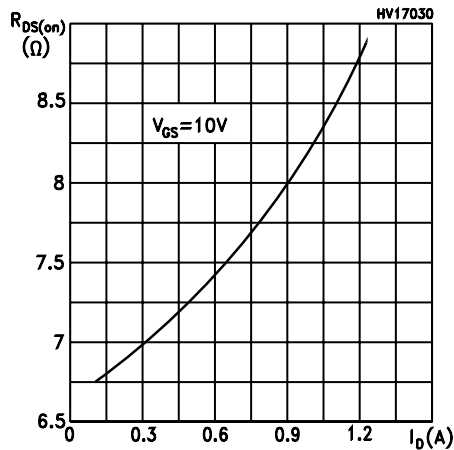
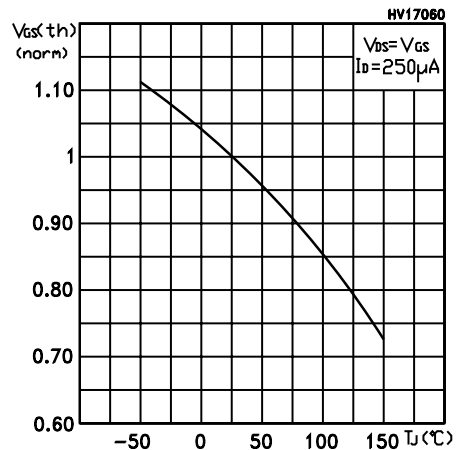
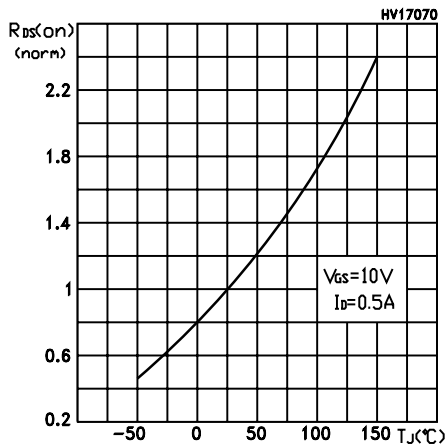
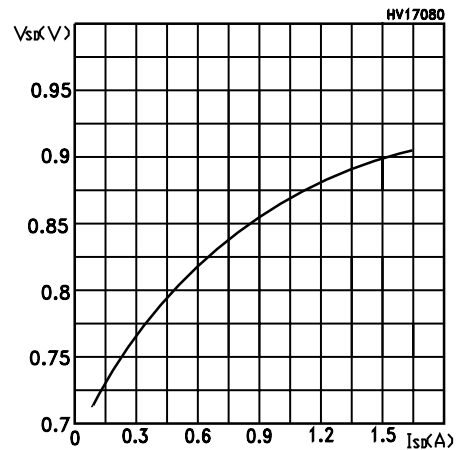
**Figure 2. Thermal impedance for SOT-223**

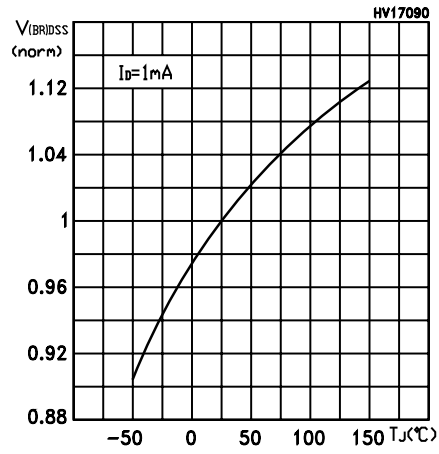
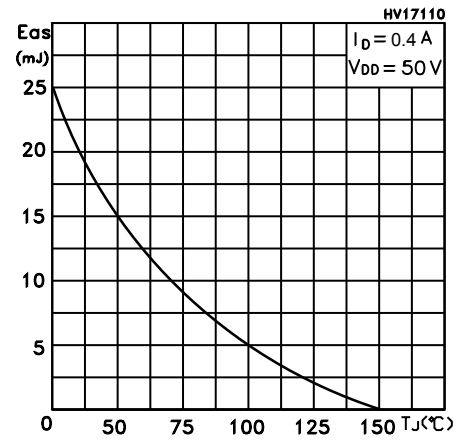
**Figure 3. Safe operating area for TO-92**

**Figure 4. Thermal impedance for TO-92**

**Figure 5. Output characteristics**

**Figure 6. Transfer characteristics**

**Figure 7. Gate charge vs gate-source voltage**

**Figure 8. Capacitance variations**

**Figure 9. Static drain-source on-resistance**

**Figure 10. Normalized gate threshold voltage vs temperature**

**Figure 11. Normalized on-resistance vs temperature**

**Figure 12. Source-drain forward characteristics**

**Figure 13. Normalized  $V_{(BR)DSS}$  vs Temperature**

**Figure 14. Maximum avalanche energy vs temperature**



## 4 Package information

In order to meet environmental requirements, ST offers these devices in different grades of ECOPACK® packages, depending on their level of environmental compliance. ECOPACK® specifications, grade definitions and product status are available at: [www.st.com](http://www.st.com). ECOPACK® is an ST trademark.

### 4.1 SOT-223 package information

Figure 21. SOT-223 package outline

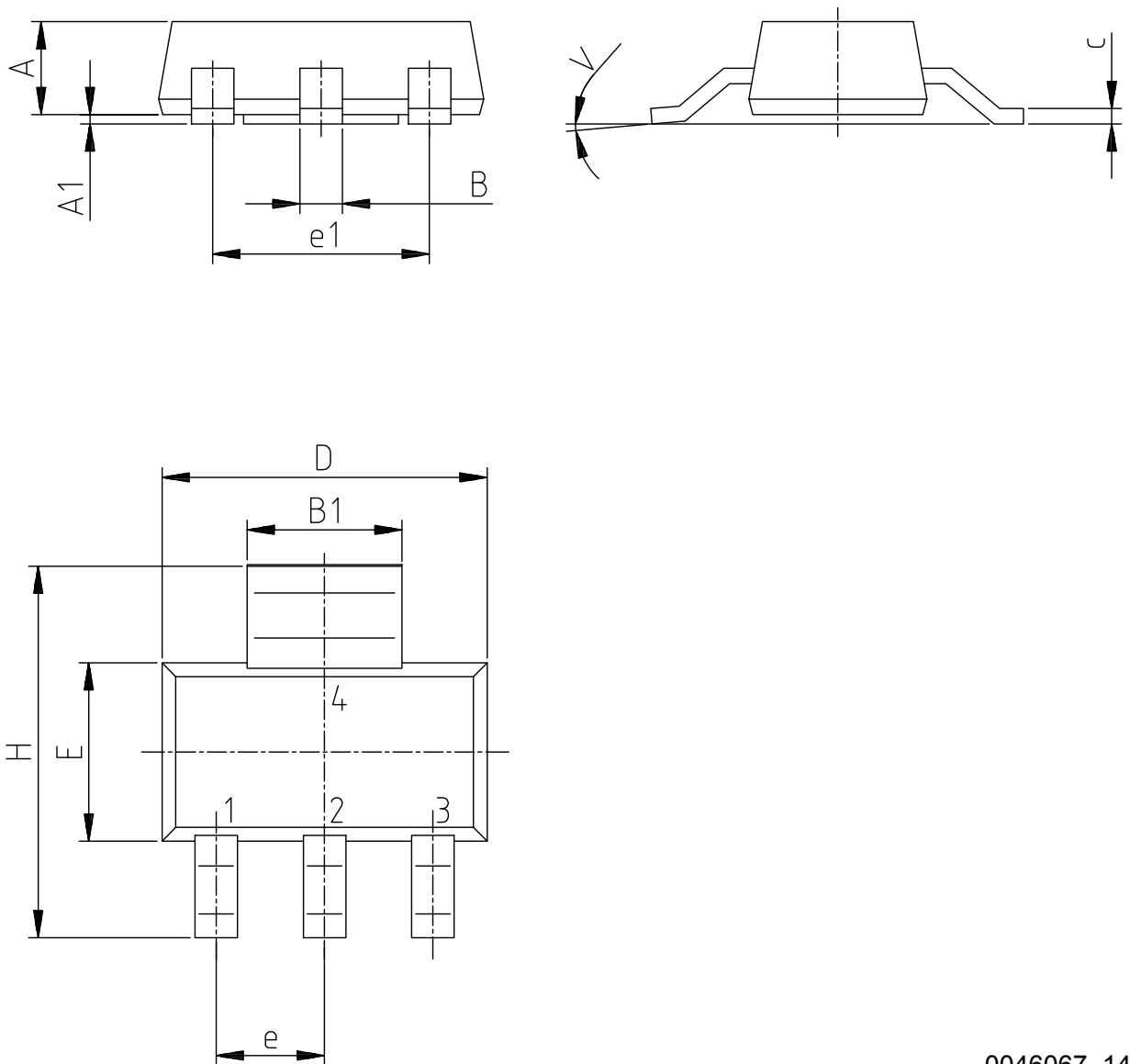

0046067\_14

**Table 8. SOT-223 package mechanical data**

Dim.	mm		
	Min.	Typ.	Max.
A			1.8
A1	0.02		0.1
B	0.6	0.7	0.85
B1	2.9	3	3.15
c	0.24	0.26	0.35
D	6.3	6.5	6.7
e		2.3	
e1		4.6	
E	3.3	3.5	3.7
H	6.7	7.0	7.3
V			10°

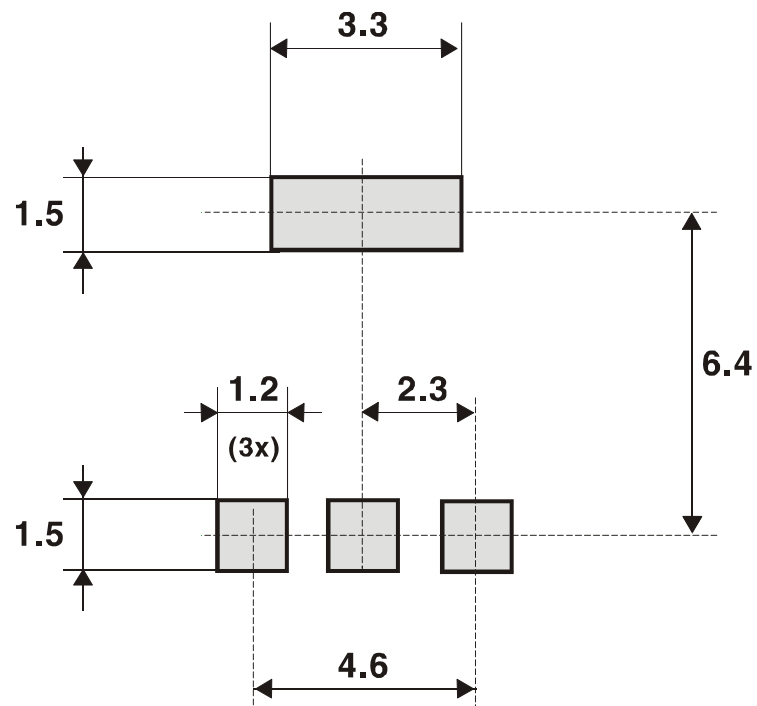
**Figure 22. SOT-223 recommended footprint (dimensions are in mm)**

0046067

## 4.2 TO-92 Ammopack package information

Figure 23. TO-92 Ammopack package outline

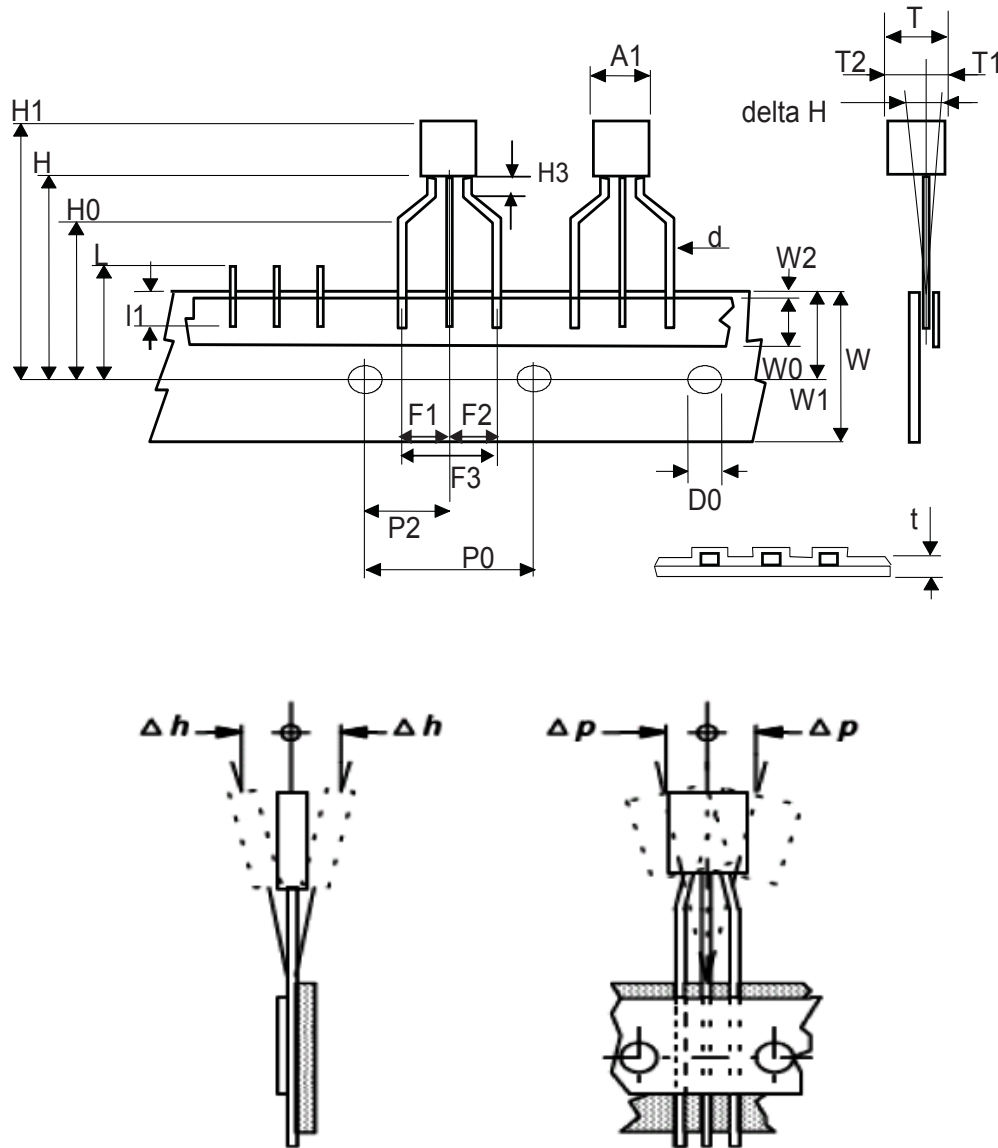

0050910\_Rev\_22

**Table 9. TO-92 Ammopack mechanical data**

Dim.	mm		
	Min.	Typ.	Max.
A1			4.80
T			3.80
T1			1.60
T2			2.30
d	0.45	0.47	0.48
P0	12.50	12.70	12.90
P2	5.65	6.35	7.05
F1, F2	2.40	2.50	2.94
F3	4.98	5.08	5.48
delta H	-2.00		2.00
W	17.50	18.00	19.00
W0	5.50	6.00	6.50
W1	8.50	9.00	9.25
W2			0.50
H		18.50	21.00
H0	15.50	16.00	18.20
H1		25.00	27.00
H3	0.50	1.00	2.00
D0	3.80	4.00	4.20
t			0.90
L			11.00
l1	3.00		
delta P	-1.00		1.00

## 5 Ordering information

**Table 10. Order codes**

Order code	Marking	Package	Packing
STN1HNK60	N1HNK60	SOT-223	Tape and reel
STQ1HNK60R-AP	1HNK60R	TO-92	Ammopak

## Revision history

**Table 11. Document revision history**

Date	Version	Changes
20-Aug-2018	1	Initial release.

## Contents

<b>1</b>	<b>Electrical ratings</b> .....	<b>2</b>
<b>2</b>	<b>Electrical characteristics</b> .....	<b>3</b>
<b>2.1</b>	<b>Electrical characteristics curves</b> .....	<b>5</b>
<b>3</b>	<b>Test circuits</b> .....	<b>8</b>
<b>4</b>	<b>Package information</b> .....	<b>9</b>
<b>4.1</b>	<b>SOT-223 package information</b> .....	<b>9</b>
<b>4.2</b>	<b>TO-92 Ammopack package information</b> .....	<b>10</b>
<b>5</b>	<b>Ordering information</b> .....	<b>13</b>
	<b>Revision history</b> .....	<b>14</b>

**IMPORTANT NOTICE – PLEASE READ CAREFULLY**

STMicroelectronics NV and its subsidiaries (“ST”) reserve the right to make changes, corrections, enhancements, modifications, and improvements to ST products and/or to this document at any time without notice. Purchasers should obtain the latest relevant information on ST products before placing orders. ST products are sold pursuant to ST’s terms and conditions of sale in place at the time of order acknowledgement.

Purchasers are solely responsible for the choice, selection, and use of ST products and ST assumes no liability for application assistance or the design of Purchasers’ products.

No license, express or implied, to any intellectual property right is granted by ST herein.

Resale of ST products with provisions different from the information set forth herein shall void any warranty granted by ST for such product.



ST and the ST logo are trademarks of ST. All other product or service names are the property of their respective owners.

Information in this document supersedes and replaces information previously supplied in any prior versions of this document.







© 2018 STMicroelectronics – All rights reserved

## Looking for pricing, stock, or lifecycle information?

Click below to explore more details on WIN SOURCE:

-  [View STD1NK60-1 on WIN SOURCE](#)
-  [STMicroelectronics Information](#)

## Optimize Your Supply Chain with WIN SOURCE Solutions

-  Global Sourcing Solution
-  Obsolete Management
-  Cost Control Management
-  Shortage Management
-  Alternative Solution
-  Excess Inventory Management