



THE DATASHEET OF STD5N52K3





STB5N52K3, STD5N52K3, STF5N52K3 STP5N52K3, STU5N52K3

N-channel 525 V, 1.2 Ω , 4.4 A SuperMESH3™ Power MOSFET
D²PAK, DPAK, TO-220FP, TO-220, IPAK

Features

Order codes	V _{DSS}	R _{DS(on)} max	I _D	P _w
STB5N52K3	525 V	< 1.5 Ω	4.4 A	70 W
STD5N52K3				70 W
STF5N52K3				25 W
STP5N52K3				70 W
STU5N52K3				70 W

- 100% avalanche tested
- Extremely high dv/dt capability
- Gate charge minimized
- Very low intrinsic capacitance
- Improved diode reverse recovery characteristics
- Zener-protected

Application

Switching applications

Description

These devices are made using the SuperMESH3™ Power MOSFET technology that is obtained via improvements applied to STMicroelectronics' SuperMESH™ technology combined with a new optimized vertical structure. The resulting product has an extremely low on resistance, superior dynamic performance and high avalanche capability, making it especially suitable for the most demanding applications.

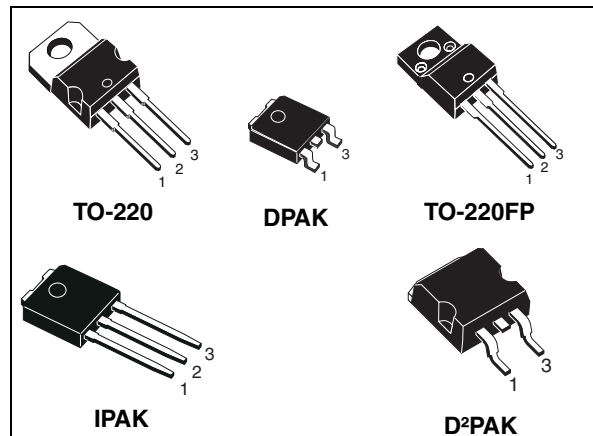

Figure 1. Internal schematic diagram

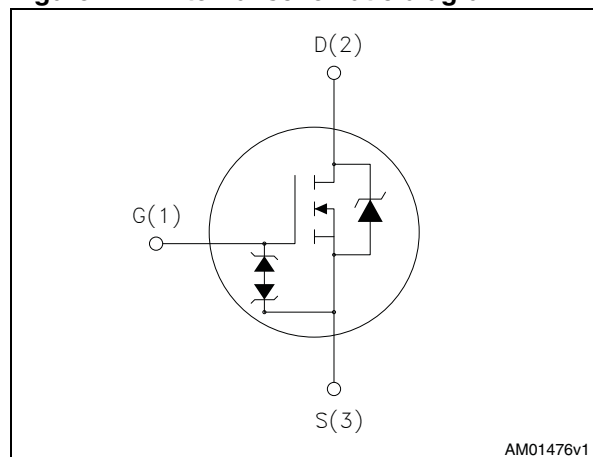

Table 1. Device summary

Order codes	Marking	Package	Packaging
STB5N52K3	5N52K3	D ² PAK	Tape and reel
STD5N52K3		DPAK	
STF5N52K3		TO-220FP	Tube
STP5N52K3		TO-220	
STU5N52K3		IPAK	

Contents

1	Electrical ratings	3
2	Electrical characteristics	4
2.1	Electrical characteristics (curves)	6
3	Test circuits	9
4	Package mechanical data	10
5	Package mechanical data	19
6	Revision history	22

1 Electrical ratings

Table 2. Absolute maximum ratings

Symbol	Parameter	Value			Unit
		TO-220 D ² PAK	DPAK IPAK	TO-220FP	
V _{DS}	Drain- source voltage	525			V
V _{GS}	Gate- source voltage	± 30			V
I _D	Drain current (continuous) at T _C = 25 °C	4.4		4.4 ⁽¹⁾	A
I _D	Drain current (continuous) at T _C = 100 °C	2.77		2.77 ⁽¹⁾	A
I _{DM} ⁽²⁾	Drain current (pulsed)	17.6		17.6 ⁽¹⁾	A
P _{TOT}	Total dissipation at T _C = 25 °C	70		25	W
I _{AR}	Avalanche current, repetitive or not-repetitive (pulse width limited by T _J max)	2.2			A
E _{AS}	Single pulse avalanche energy (starting T _J = 25 °C, I _D = I _{AR} , V _{DD} = 50 V)	100			mJ
dv/dt ⁽³⁾	Peak diode recovery voltage slope	12			V/ns
V _{ISO}	Insulation withstand voltage (AC)			2500	V
T _J T _{stg}	Operating junction temperature Storage temperature	- 55 to 150			°C

- Limited only by maximum temperature allowed
- Pulse width limited by safe operating area
- $I_{SD} \leq 4.4 \text{ A}$, $di/dt \leq 100 \text{ A}/\mu\text{s}$, $V_{DS \text{ peak}} \leq V_{(BR)DSS}$, $V_{DD} = 80\% V_{(BR)DSS}$.

Table 3. Thermal data

Symbol	Parameter	Value					Unit
		TO-220	D ² PAK	TO-220FP	IPAK	DPAK	
R _{thj-case}	Thermal resistance junction-case max.	1.79		5		1.79	°C/W
R _{thj-amb}	Thermal resistance junction-ambient max	62.5			100		°C/W
R _{thj-pcb}	Thermal resistance junction-pcb max.		30			50	°C/W
T _J	Maximum lead temperature for soldering purpose	300		300			°C/W

2 Electrical characteristics

(T_{case} = 25 °C unless otherwise specified)

Table 4. On /off states

Symbol	Parameter	Test conditions	Min.	Typ.	Max.	Unit
V _{(BR)DSS}	Drain-source breakdown voltage	I _D = 1 mA, V _{GS} = 0	525			V
I _{DSS}	Zero gate voltage drain current (V _{GS} = 0)	V _{DS} = Max rating V _{DS} = Max rating, T _C = 125 °C			1 50	μA μA
I _{GSS}	Gate-body leakage current (V _{DS} = 0)	V _{GS} = ± 20 V; V _{DS} = 0			10	μA
V _{GS(th)}	Gate threshold voltage	V _{DS} = V _{GS} , I _D = 50 μA	3	3.75	4.5	V
R _{DS(on)}	Static drain-source on resistance	V _{GS} = 10 V, I _D = 2.2 A		1.2	1.5	Ω

Table 5. Dynamic

Symbol	Parameter	Test conditions	Min.	Typ.	Max.	Unit
C _{iss}	Input capacitance	V _{DS} = 100 V, f = 1 MHz, V _{GS} = 0	-	545	-	pF
C _{oss}	Output capacitance			45		
C _{rss}	Reverse transfer capacitance			8		
C _{oss eq.} ⁽¹⁾	Equivalent output capacitance	V _{DS} = 0 to 420 V, V _{GS} = 0	-	33	-	pF
R _g	Gate input resistance	f = 1 MHz open drain	-	4.7	-	Ω
Q _g	Total gate charge	V _{DD} = 420 V, I _D = 4.4 A, V _{GS} = 10 V <i>(see Figure 19)</i>	-	17	-	nC
Q _{gs}	Gate-source charge			3		
Q _{gd}	Gate-drain charge			10		

1. C_{oss eq.} is defined as a constant equivalent capacitance giving the same charging time as C_{oss} when V_{DS} increases from 0 to 80% V_{DS}

Table 6. Switching times

Symbol	Parameter	Test conditions	Min.	Typ.	Max	Unit
$t_{d(on)}$	Turn-on delay time	$V_{DD} = 420\text{ V}$, $I_D = 4.4\text{ A}$, $R_G = 4.7\ \Omega$, $V_{GS} = 10\text{ V}$ (see Figure 18)	-	9	-	ns
t_r	Rise time			11		ns
$t_{d(off)}$	Turn-off-delay time			29		ns
t_f	Fall time			16		ns

Table 7. Source drain diode

Symbol	Parameter	Test conditions	Min.	Typ.	Max	Unit
I_{SD}	Source-drain current		-		4.4	A
$I_{SDM}^{(1)}$	Source-drain current (pulsed)				17.6	A
$V_{SD}^{(2)}$	Forward on voltage	$I_{SD} = 4.4\text{ A}$, $V_{GS} = 0$	-		1.6	V
t_{rr}	Reverse recovery time	$I_{SD} = 4.4\text{ A}$, $di/dt = 100\text{ A}/\mu\text{s}$ $V_{DD} = 60\text{ V}$ (see Figure 20)	-	210		ns
Q_{rr}	Reverse recovery charge			1.3		μC
I_{RRM}	Reverse recovery current			12		A
t_{rr}	Reverse recovery time	$I_{SD} = 4.4\text{ A}$, $di/dt = 100\text{ A}/\mu\text{s}$ $V_{DD} = 60\text{ V}$ $T_J = 150\text{ }^\circ\text{C}$ (see Figure 20)	-	240		ns
Q_{rr}	Reverse recovery charge			1.6		μC
I_{RRM}	Reverse recovery current			13		A

1. Pulse width limited by safe operating area

2. Pulsed: pulse duration = 300 μs , duty cycle 1.5%

Table 8. Gate-source Zener diode

Symbol	Parameter	Test conditions	Min.	Typ.	Max.	Unit
BV_{GSO}	Gate-source breakdown voltage	$I_{gs} = \pm 1\text{ mA}$ (open drain)	30		-	V

The built-in back-to-back Zener diodes have specifically been designed to enhance not only the device's ESD capability, but also to make them safely absorb possible voltage transients that may occasionally be applied from gate to source. In this respect the Zener voltage is appropriate to achieve an efficient and cost-effective intervention to protect the device's integrity. These integrated Zener diodes thus avoid the usage of external components.

2.1 Electrical characteristics (curves)

Figure 2. Safe operating area TO-220, D²PAK Figure 3. Thermal impedance TO-220, D²PAK

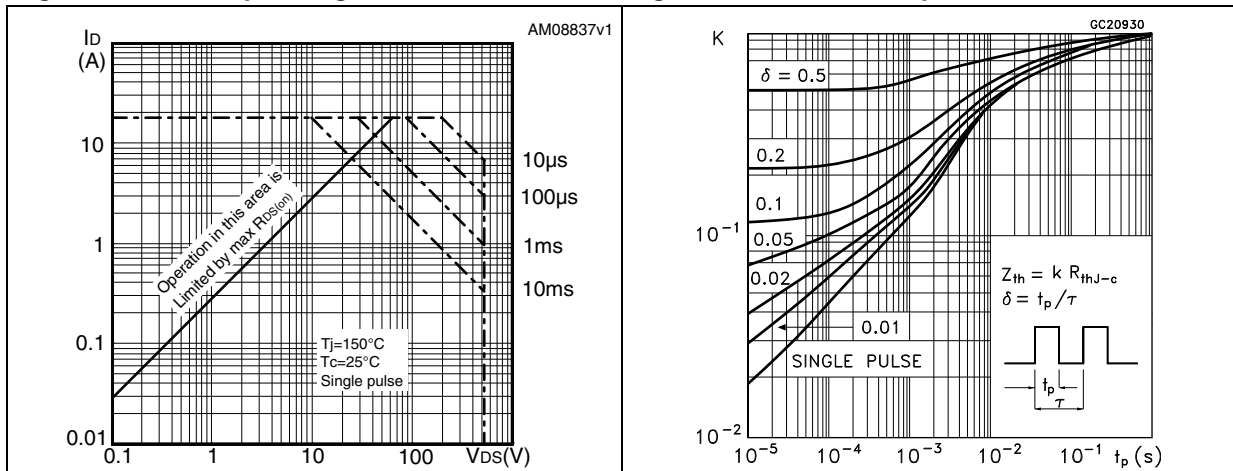

Figure 4. Safe operating area TO-220FP Figure 5. Thermal impedance TO-220FP

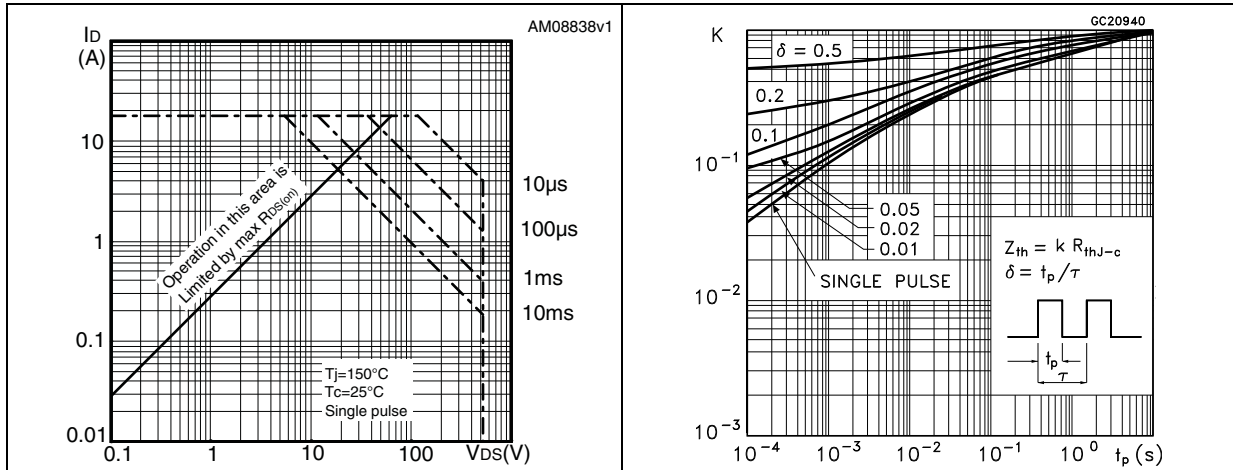

Figure 6. Safe operating area DPAK, IPAK Figure 7. Thermal impedance DPAK, IPAK

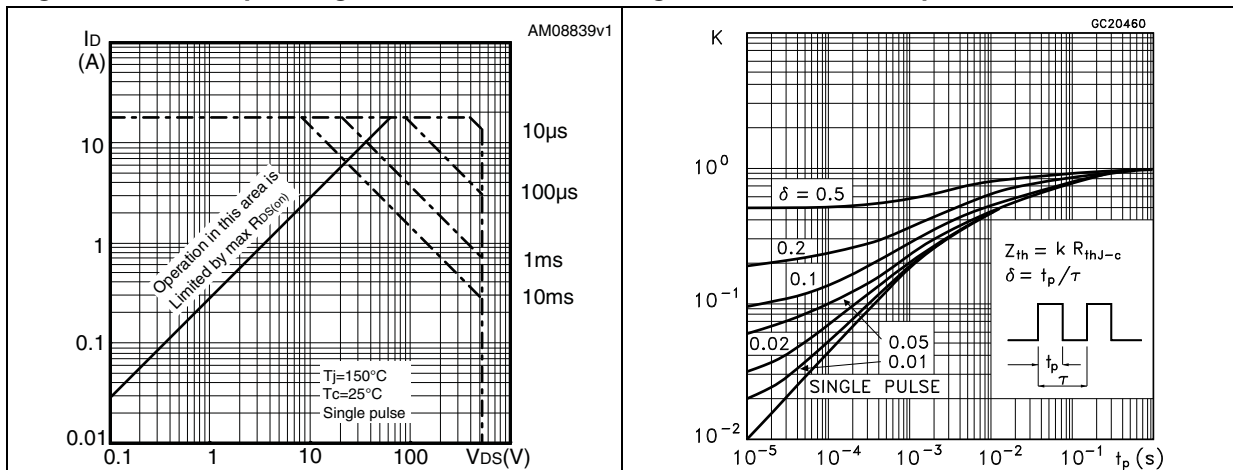

Figure 8. Output characteristics

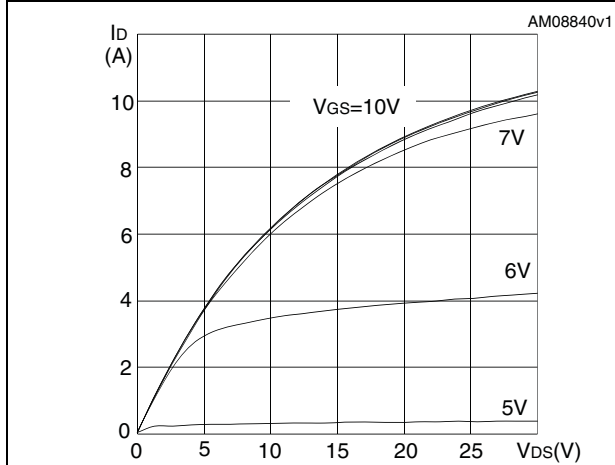

Figure 9. Transfer characteristics

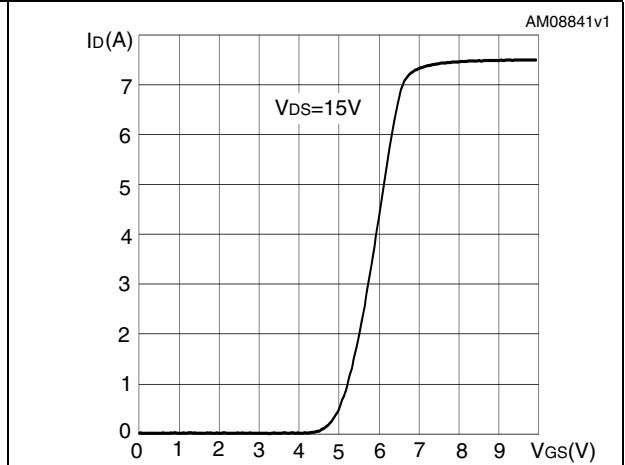

Figure 10. Normalized B_{VDSS} vs temperature

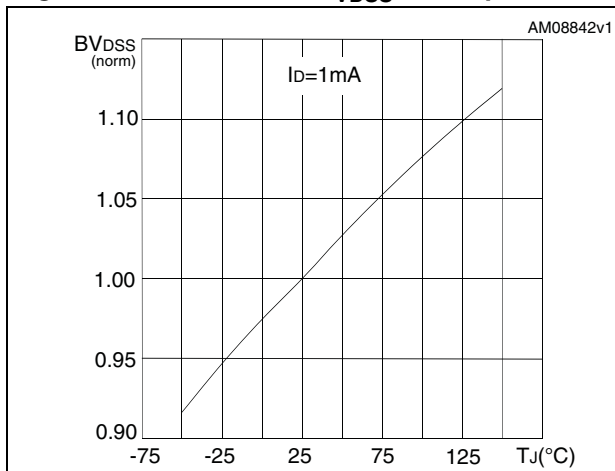

Figure 11. Static drain-source on resistance

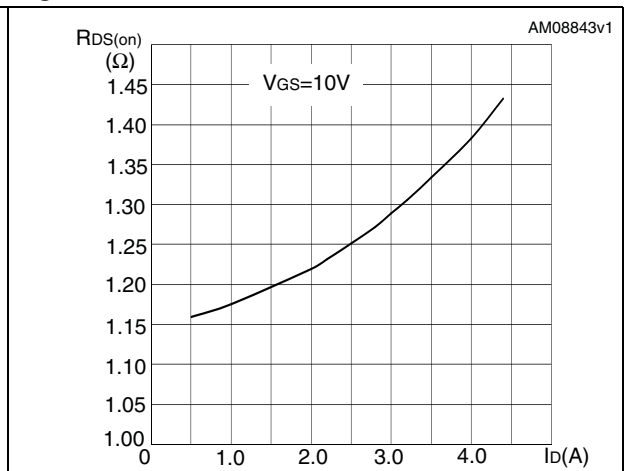

Figure 12. Gate charge vs gate-source voltage

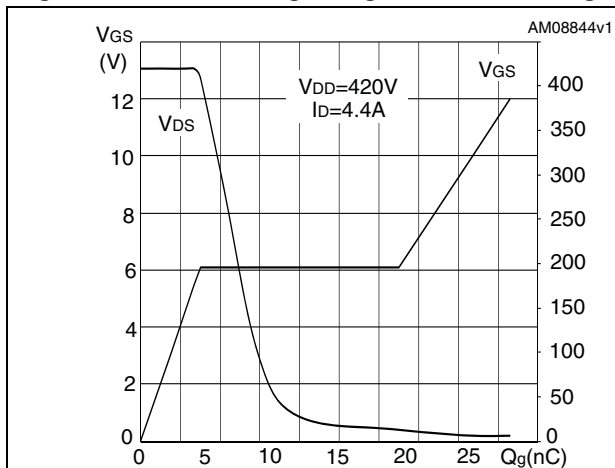

Figure 13. Capacitance variations

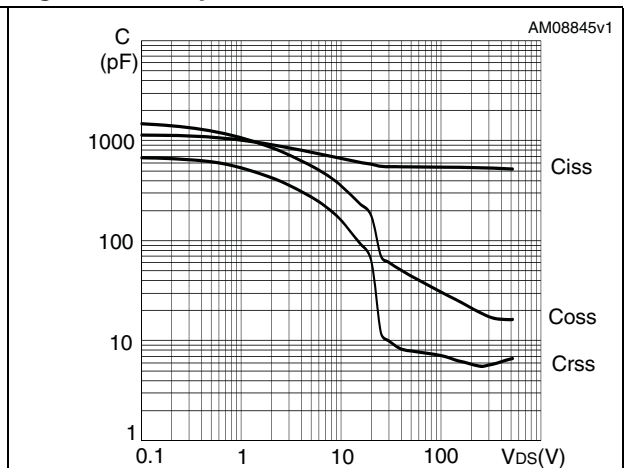

Figure 14. Normalized gate threshold voltage vs temperature

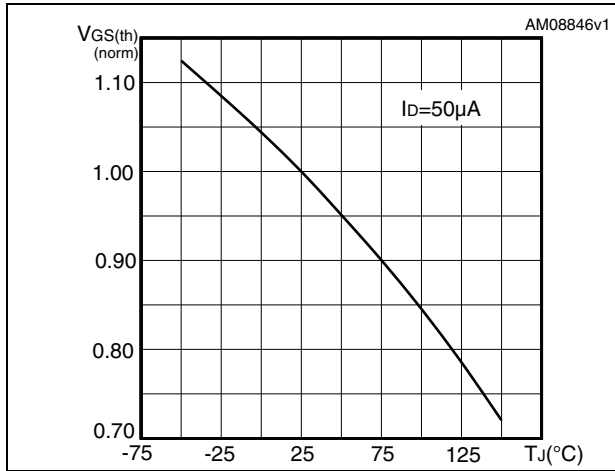

Figure 15. Normalized on resistance vs temperature

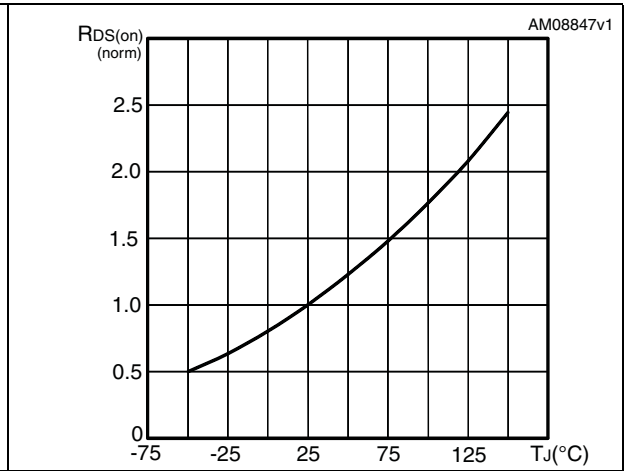

Figure 16. Source-drain diode forward characteristics

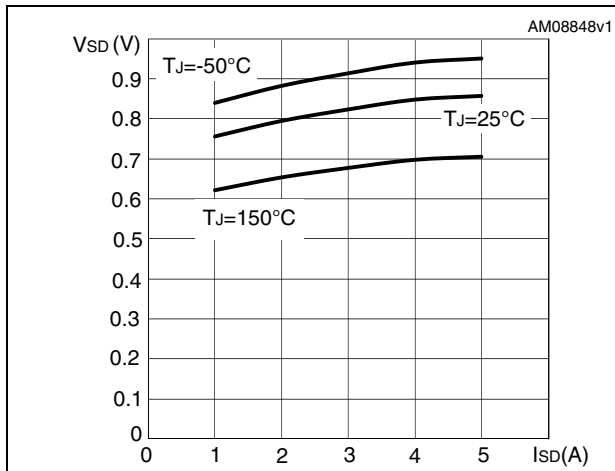
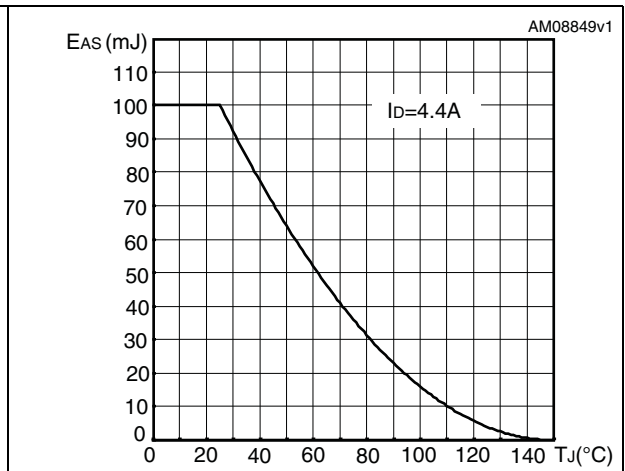
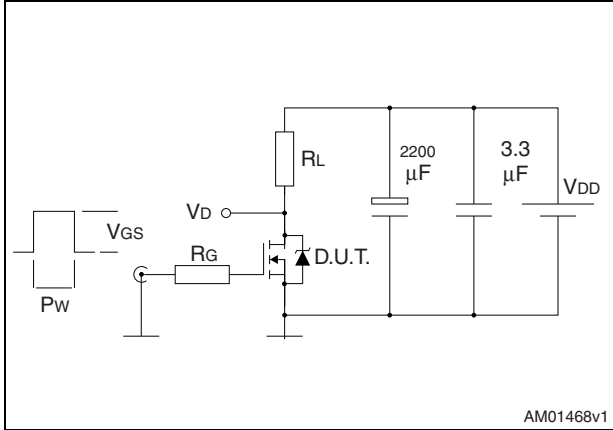

Figure 17. Maximum avalanche energy vs starting Tj



3 Test circuits

Figure 18. Switching times test circuit for resistive load



AM01468v1

Figure 19. Gate charge test circuit

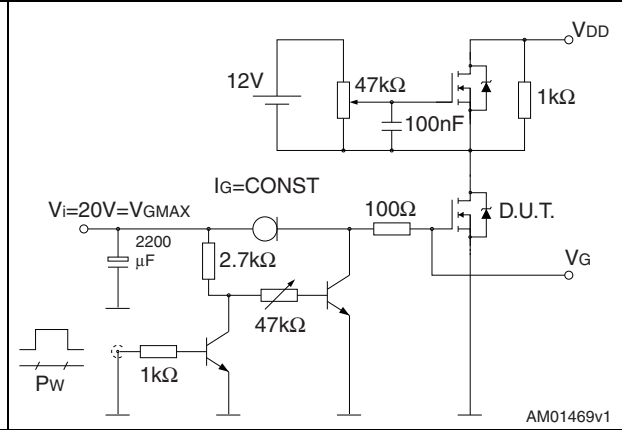

AM01469v1

Figure 20. Test circuit for inductive load switching and diode recovery times

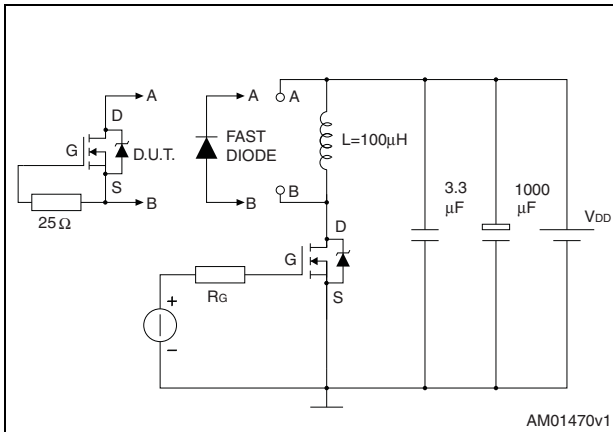

AM01470v1

Figure 21. Unclamped inductive load test circuit

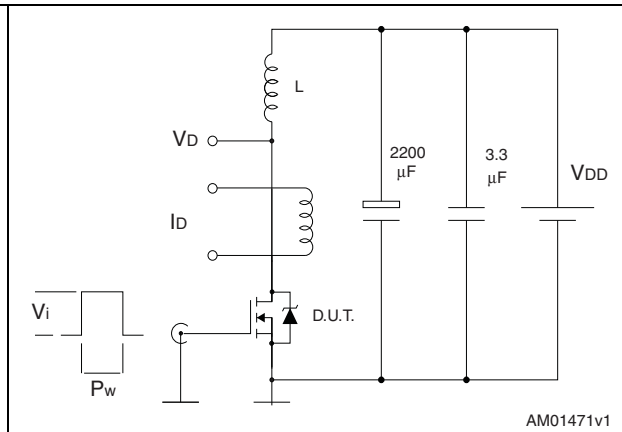

AM01471v1

Figure 22. Unclamped inductive waveform

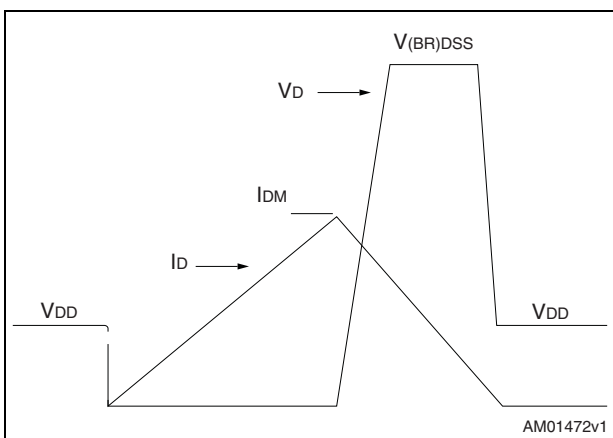

AM01472v1

Figure 23. Switching time waveform

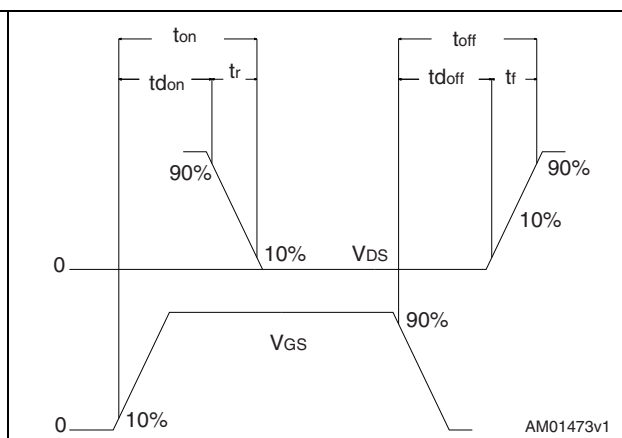

AM01473v1

4 Package mechanical data

In order to meet environmental requirements, ST offers these devices in different grades of ECOPACK[®] packages, depending on their level of environmental compliance. ECOPACK[®] specifications, grade definitions and product status are available at: www.st.com. ECOPACK is an ST trademark.

Table 9. TO-220FP mechanical data

Dim.	mm		
	Min.	Typ.	Max.
A	4.4		4.6
B	2.5		2.7
D	2.5		2.75
E	0.45		0.7
F	0.75		1
F1	1.15		1.70
F2	1.15		1.70
G	4.95		5.2
G1	2.4		2.7
H	10		10.4
L2		16	
L3	28.6		30.6
L4	9.8		10.6
L5	2.9		3.6
L6	15.9		16.4
L7	9		9.3
Dia	3		3.2

Figure 24. TO-220FP drawing

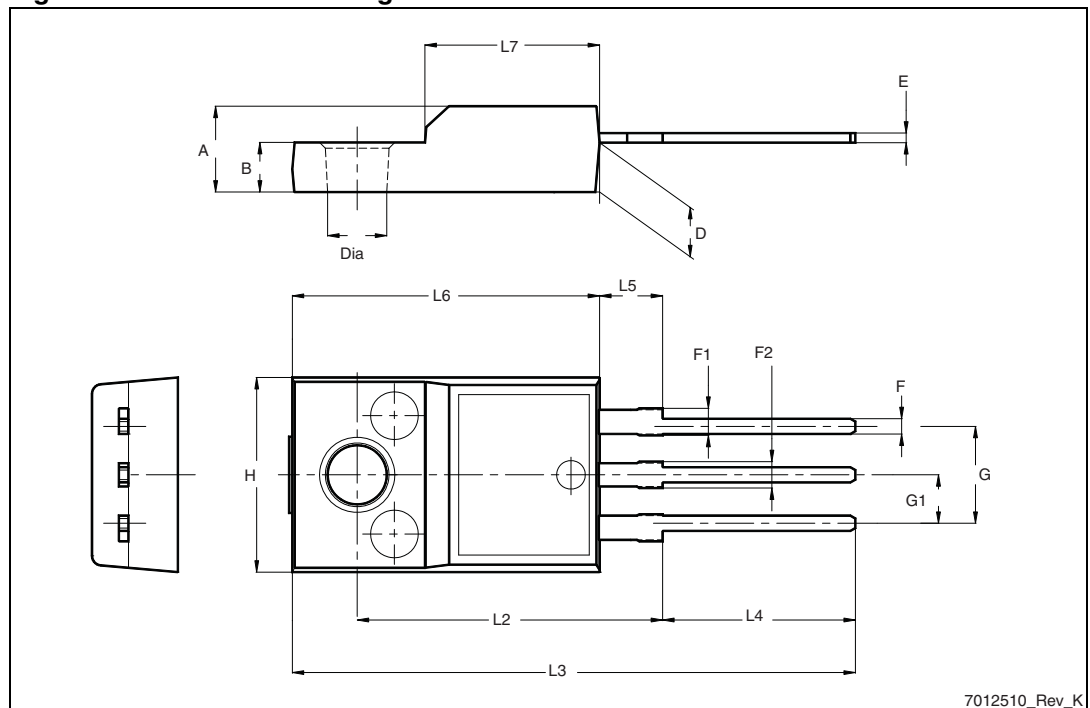

Table 10. DPAK (TO-252) mechanical data

Dim.	mm		
	Min.	Typ.	Max.
A	2.20		2.40
A1	0.90		1.10
A2	0.03		0.23
b	0.64		0.90
b4	5.20		5.40
c	0.45		0.60
c2	0.48		0.60
D	6.00		6.20
D1		5.10	
E	6.40		6.60
E1		4.70	
e		2.28	
e1	4.40		4.60
H	9.35		10.10
L	1		
L1		2.80	
L2		0.80	
L4	0.60		1
R		0.20	
V2	0°		8°

Figure 25. DPAK (TO-252) drawing

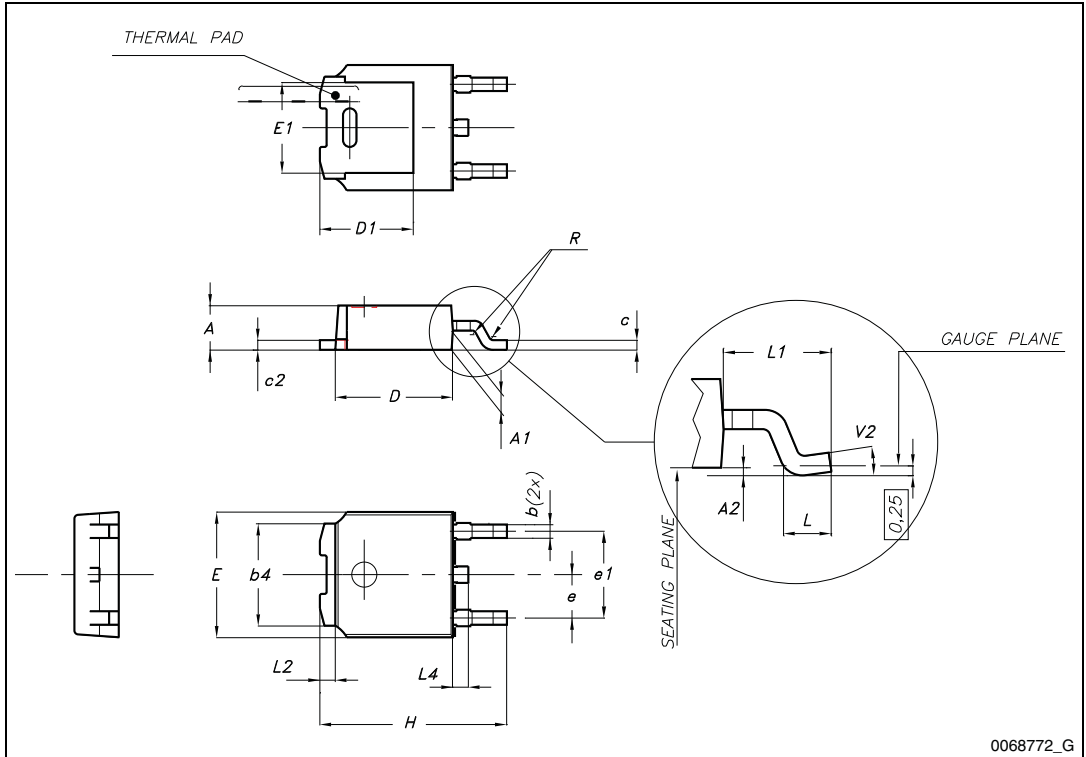

Table 11. TO-220 type A mechanical data

Dim.	mm		
	Min.	Typ.	Max.
A	4.40		4.60
b	0.61		0.88
b1	1.14		1.70
c	0.48		0.70
D	15.25		15.75
D1		1.27	
E	10		10.40
e	2.40		2.70
e1	4.95		5.15
F	1.23		1.32
H1	6.20		6.60
J1	2.40		2.72
L	13		14
L1	3.50		3.93
L20		16.40	
L30		28.90	
ØP	3.75		3.85
Q	2.65		2.95

Figure 26. TO-220 type A drawing

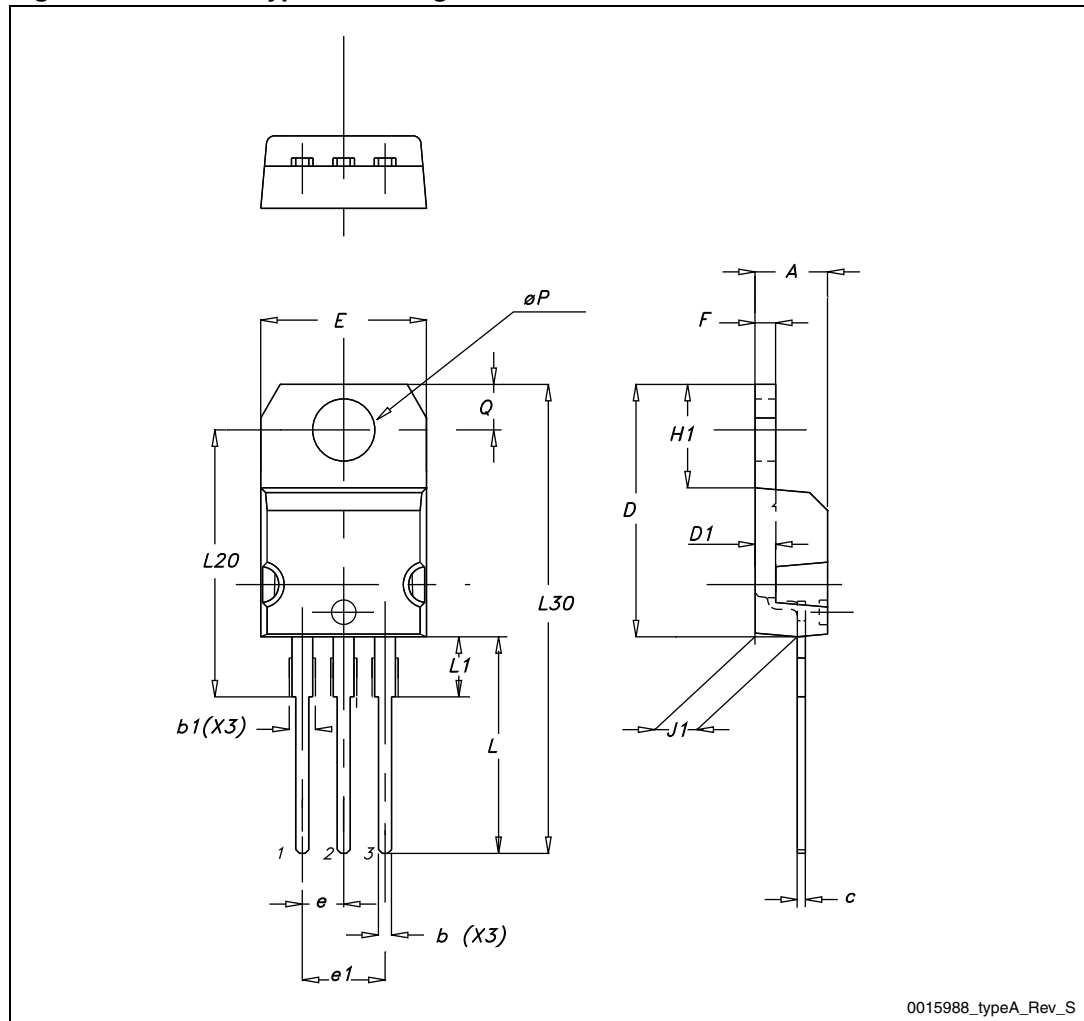

Table 12. D²PAK (TO-263) mechanical data

Dim.	mm		
	Min.	Typ.	Max.
A	4.40		4.60
A1	0.03		0.23
b	0.70		0.93
b2	1.14		1.70
c	0.45		0.60
c2	1.23		1.36
D	8.95		9.35
D1	7.50		
E	10		10.40
E1	8.50		
e		2.54	
e1	4.88		5.28
H	15		15.85
J1	2.49		2.69
L	2.29		2.79
L1	1.27		1.40
L2	1.30		1.75
R		0.4	
V2	0°		8°

Figure 27. D²PAK (TO-263) drawing

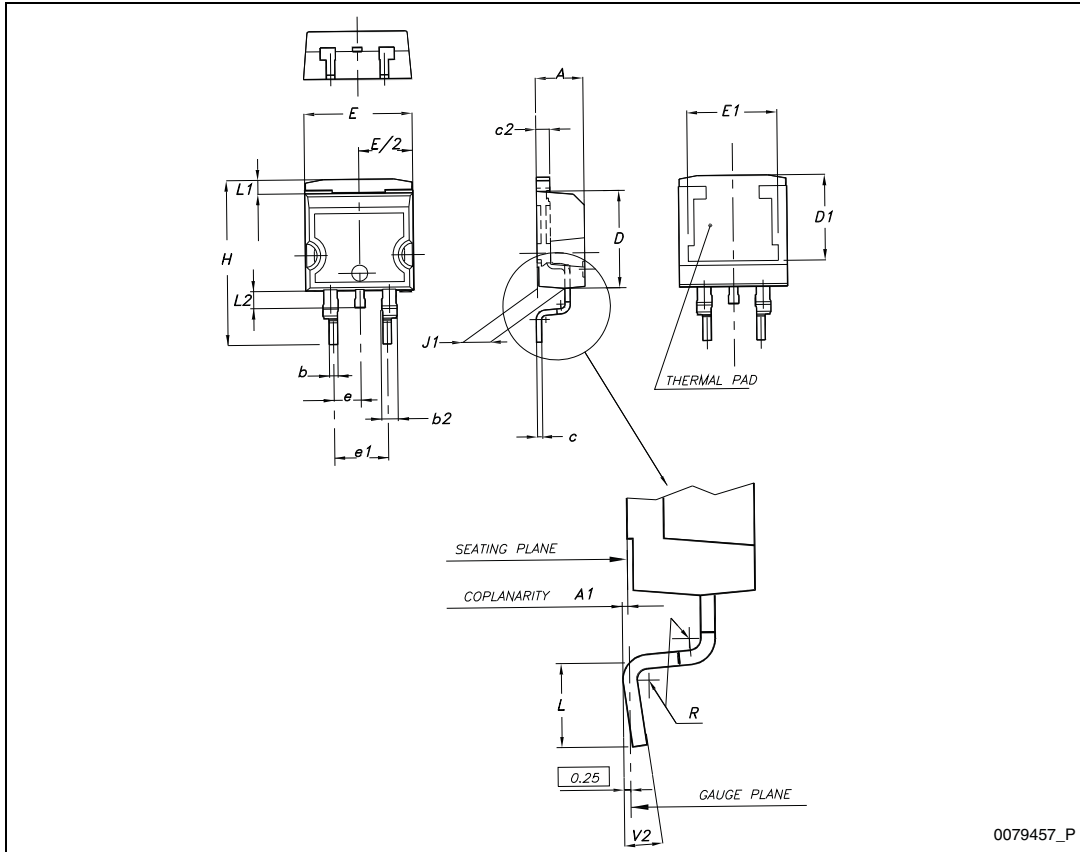

Table 13. IPAK (TO-251) mechanical data

DIM.	mm.		
	min.	typ	max.
A	2.20		2.40
A1	0.90		1.10
b	0.64		0.90
b2			0.95
b4	5.20		5.40
B5		0.3	
c	0.45		0.60
c2	0.48		0.60
D	6.00		6.20
E	6.40		6.60
e		2.28	
e1	4.40		4.60

Table 13. IPAK (TO-251) mechanical data

H		16.10	
L	9.00		9.40
L1	0.80		1.20
L2		0.80	1.00
V1		10 °	

Figure 28. IPAK (TO-251) drawing

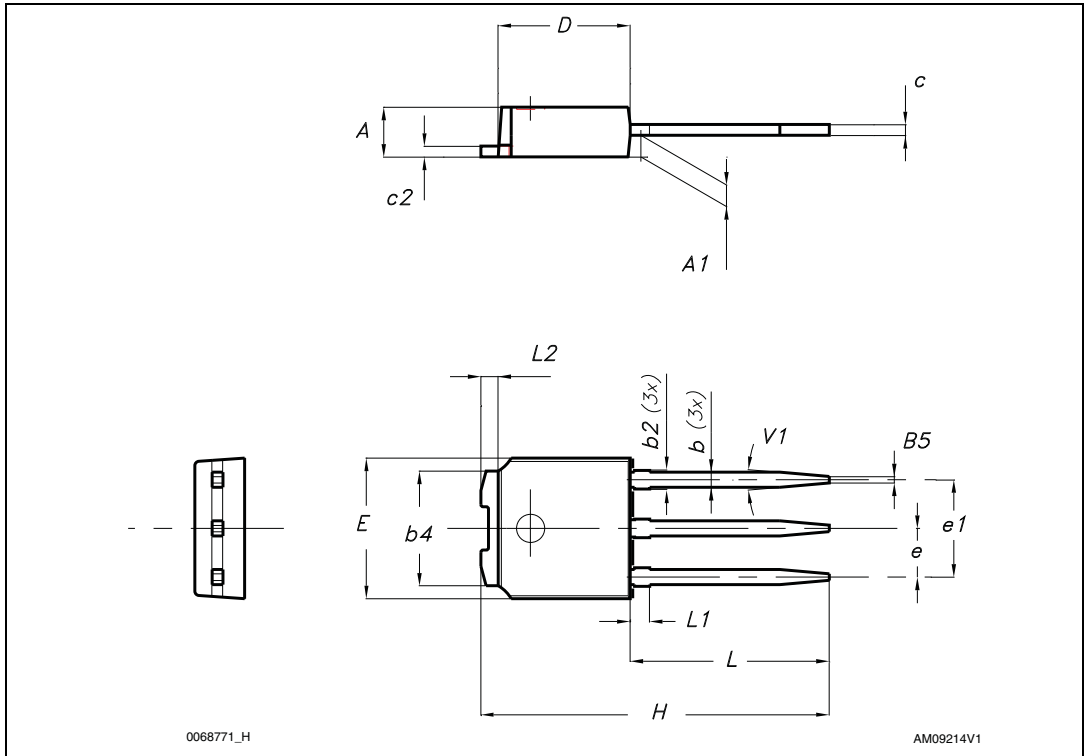

5 Package mechanical data

Table 14. D²PAK (TO-263) tape and reel mechanical data

Tape			Reel		
Dim.	mm		Dim.	mm	
	Min.	Max.		Min.	Max.
A0	10.5	10.7	A		330
B0	15.7	15.9	B	1.5	
D	1.5	1.6	C	12.8	13.2
D1	1.59	1.61	D	20.2	
E	1.65	1.85	G	24.4	26.4
F	11.4	11.6	N	100	
K0	4.8	5.0	T		30.4
P0	3.9	4.1			
P1	11.9	12.1	Base qty		1000
P2	1.9	2.1	Bulk qty		1000
R	50				
T	0.25	0.35			
W	23.7	24.3			

Figure 29. D²PAK footprint^(a)

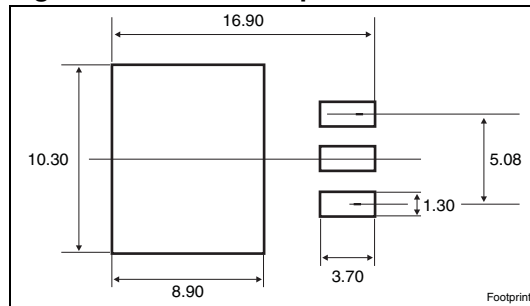

a. All dimension are in millimeters

Table 15. DPAK (TO-252) tape and reel mechanical data

Tape			Reel		
Dim.	mm		Dim.	mm	
	Min.	Max.		Min.	Max.
A0	6.8	7	A		330
B0	10.4	10.6	B	1.5	
B1		12.1	C	12.8	13.2
D	1.5	1.6	D	20.2	
D1	1.5		G	16.4	18.4
E	1.65	1.85	N	50	
F	7.4	7.6	T		22.4
K0	2.55	2.75			
P0	3.9	4.1	Base qty.		2500
P1	7.9	8.1	Bulk qty.		2500
P2	1.9	2.1			
R	40				
T	0.25	0.35			
W	15.7	16.3			

Figure 30. DPAK footprint^(b)

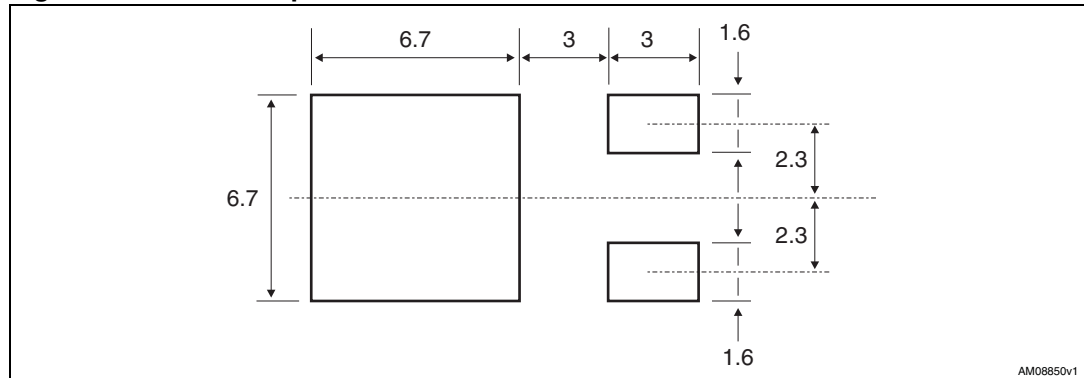

b. All dimension are in millimeters

Figure 31. Tape for DPAK (TO-252) and D²PAK (TO-263)

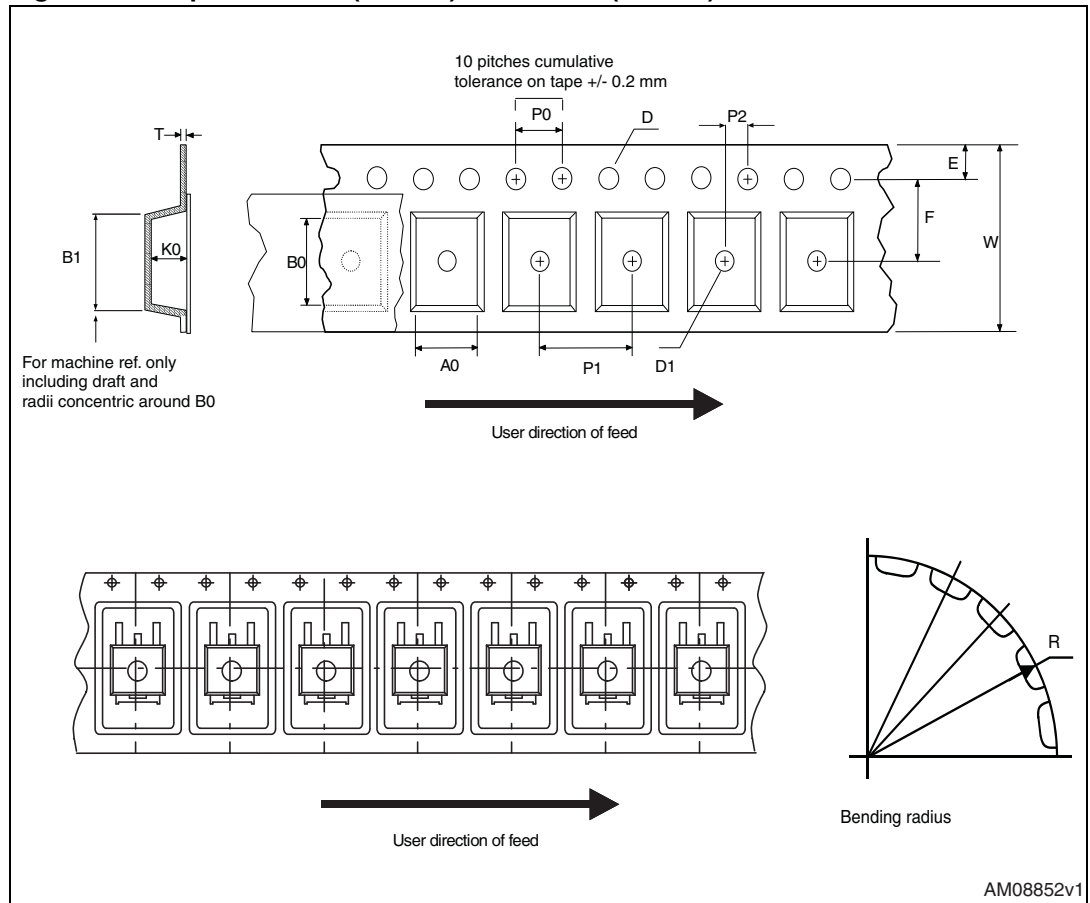
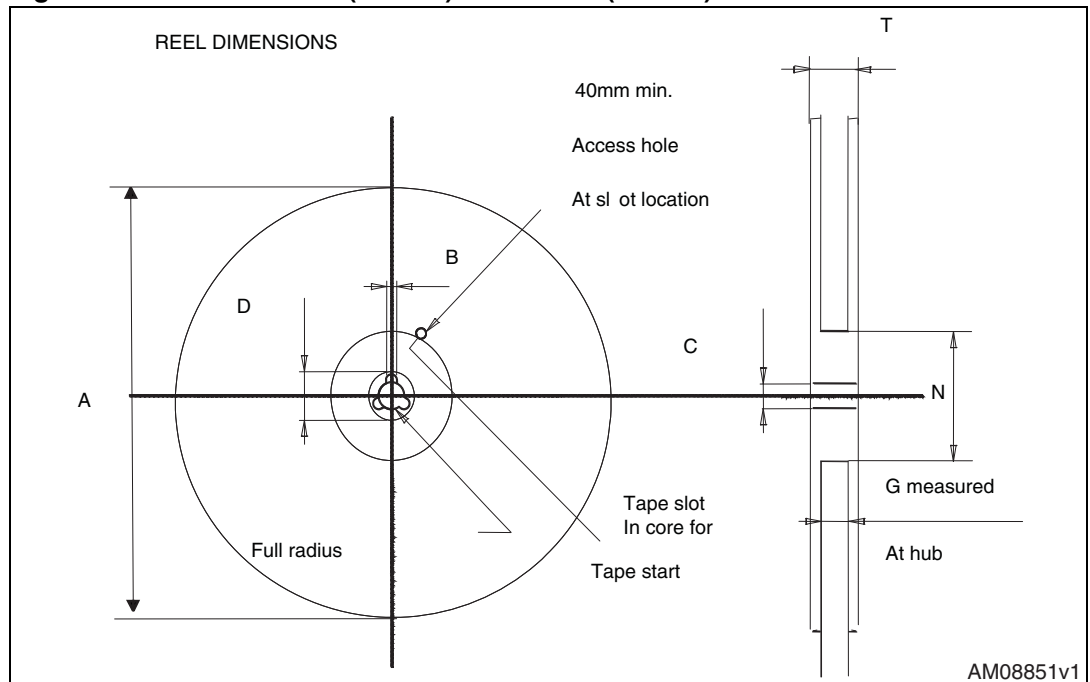

Figure 32. Reel for DPAK (TO-252) and D²PAK (TO-263)



6 Revision history

Table 16. Document revision history

Date	Revision	Changes
05-Jan-2010	1	First release.
14-Dec-2010	2	Document status promoted from preliminary data to datasheet.

Please Read Carefully:

Information in this document is provided solely in connection with ST products. STMicroelectronics NV and its subsidiaries ("ST") reserve the right to make changes, corrections, modifications or improvements, to this document, and the products and services described herein at any time, without notice.

All ST products are sold pursuant to ST's terms and conditions of sale.

Purchasers are solely responsible for the choice, selection and use of the ST products and services described herein, and ST assumes no liability whatsoever relating to the choice, selection or use of the ST products and services described herein.

No license, express or implied, by estoppel or otherwise, to any intellectual property rights is granted under this document. If any part of this document refers to any third party products or services it shall not be deemed a license grant by ST for the use of such third party products or services, or any intellectual property contained therein or considered as a warranty covering the use in any manner whatsoever of such third party products or services or any intellectual property contained therein.

UNLESS OTHERWISE SET FORTH IN ST'S TERMS AND CONDITIONS OF SALE ST DISCLAIMS ANY EXPRESS OR IMPLIED WARRANTY WITH RESPECT TO THE USE AND/OR SALE OF ST PRODUCTS INCLUDING WITHOUT LIMITATION IMPLIED WARRANTIES OF MERCHANTABILITY, FITNESS FOR A PARTICULAR PURPOSE (AND THEIR EQUIVALENTS UNDER THE LAWS OF ANY JURISDICTION), OR INFRINGEMENT OF ANY PATENT, COPYRIGHT OR OTHER INTELLECTUAL PROPERTY RIGHT.

UNLESS EXPRESSLY APPROVED IN WRITING BY AN AUTHORIZED ST REPRESENTATIVE, ST PRODUCTS ARE NOT RECOMMENDED, AUTHORIZED OR WARRANTED FOR USE IN MILITARY, AIR CRAFT, SPACE, LIFE SAVING, OR LIFE SUSTAINING APPLICATIONS, NOR IN PRODUCTS OR SYSTEMS WHERE FAILURE OR MALFUNCTION MAY RESULT IN PERSONAL INJURY, DEATH, OR SEVERE PROPERTY OR ENVIRONMENTAL DAMAGE. ST PRODUCTS WHICH ARE NOT SPECIFIED AS "AUTOMOTIVE GRADE" MAY ONLY BE USED IN AUTOMOTIVE APPLICATIONS AT USER'S OWN RISK.

Resale of ST products with provisions different from the statements and/or technical features set forth in this document shall immediately void any warranty granted by ST for the ST product or service described herein and shall not create or extend in any manner whatsoever, any liability of ST.

ST and the ST logo are trademarks or registered trademarks of ST in various countries.

Information in this document supersedes and replaces all information previously supplied.

The ST logo is a registered trademark of STMicroelectronics. All other names are the property of their respective owners.

© 2010 STMicroelectronics - All rights reserved

STMicroelectronics group of companies



Australia - Belgium - Brazil - Canada - China - Czech Republic - Finland - France - Germany - Hong Kong - India - Israel - Italy - Japan - Malaysia - Malta - Morocco - Philippines - Singapore - Spain - Sweden - Switzerland - United Kingdom - United States of America

www.st.com



Looking for pricing, stock, or lifecycle information?

Click below to explore more details on WIN SOURCE:

-  [View STD5N52K3 on WIN SOURCE](#)
-  [STMicroelectronics Information](#)

Optimize Your Supply Chain with WIN SOURCE Solutions

-  Global Sourcing Solution
-  Obsolete Management
-  Cost Control Management
-  Shortage Management
-  Alternative Solution
-  Excess Inventory Management