



# THE DATASHEET OF STF6N62K3





# STF6N62K3, STF16N62K3, STI6N62K3, STP6N62K3, STU6N62K3

N-channel 620 V, 0.95  $\Omega$  typ., 5.5 A SuperMESH3™ Power MOSFET in TO-220FP, I<sup>2</sup>PAKFP, I<sup>2</sup>PAK, TO-220, IPAK packages

Datasheet – production data

## Features

Order codes	V <sub>DSS</sub>	R <sub>DS(on)</sub> max.	I <sub>D</sub>	P <sub>TOT</sub>
STF6N62K3	620 V	< 1.2 $\Omega$	5.5 A	30 W
STF16N62K3				30 W
STI6N62K3				90 W
STP6N62K3				90 W
STU6N62K3				90 W

- 100% avalanche tested
- Extremely high dv/dt capability
- Gate charge minimized
- Very low intrinsic capacitance
- Improved diode reverse recovery characteristics
- Zener-protected

## Applications

- Switching applications

## Description

These SuperMESH3™ Power MOSFETs are the result of improvements applied to STMicroelectronics' SuperMESH™ technology, combined with a new optimized vertical structure. These devices boast an extremely low on-resistance, superior dynamic performance and high avalanche capability, rendering them suitable for the most demanding applications.

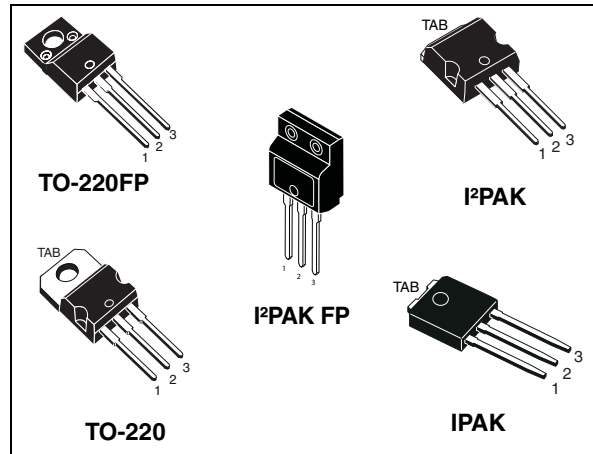

Figure 1. Internal schematic diagram

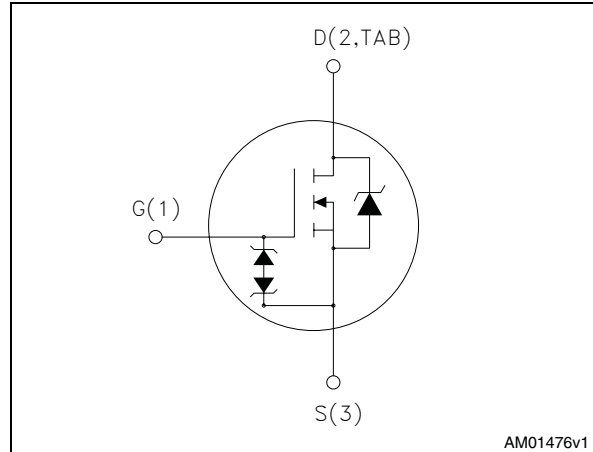

Table 1. Device summary

Order codes	Marking	Package	Packaging
STF6N62K3	6N62K3	TO-220FP	Tube
STF16N62K3		I <sup>2</sup> PAKFP	
STI6N62K3		I <sup>2</sup> PAK	
STP6N62K3		TO-220	
STU6N62K3		IPAK	

# Contents

<b>1</b>	<b>Electrical ratings</b> .....	<b>3</b>
<b>2</b>	<b>Electrical characteristics</b> .....	<b>4</b>
2.1	Electrical characteristics (curves) .....	6
<b>3</b>	<b>Test circuits</b> .....	<b>9</b>
<b>4</b>	<b>Package mechanical data</b> .....	<b>10</b>
<b>5</b>	<b>Revision history</b> .....	<b>19</b>

# 1 Electrical ratings

**Table 2. Absolute maximum ratings**

Symbol	Parameter	Value			Unit
		TO-220FP I <sup>2</sup> PAKFP	I <sup>2</sup> PAK TO-220	IPAK	
V <sub>DS</sub>	Drain-source voltage	620			V
V <sub>GS</sub>	Gate- source voltage	± 30			V
I <sub>D</sub>	Drain current (continuous) at T <sub>C</sub> = 25 °C	5.5 <sup>(1)</sup>	5.5		A
I <sub>D</sub>	Drain current (continuous) at T <sub>C</sub> = 100 °C	3 <sup>(1)</sup>	3		A
I <sub>DM</sub> <sup>(2)</sup>	Drain current (pulsed)	22 <sup>(1)</sup>	22		A
P <sub>TOT</sub>	Total dissipation at T <sub>C</sub> = 25 °C	30	90		W
I <sub>AR</sub> <sup>(3)</sup>	Avalanche current, repetitive or not-repetitive	5.5			A
E <sub>AS</sub> <sup>(4)</sup>	Single pulse avalanche energy	140			mJ
ESD	Gate-source human body model (R=1.5 kΩ, C=100 pF)	2.5			kV
dv/dt <sup>(5)</sup>	Peak diode recovery voltage slope	12			V/ns
V <sub>ISO</sub>	Insulation withstand voltage (RMS) from all three leads to external heat sink (t = 1 s; T <sub>C</sub> = 25 °C)	2500			V
T <sub>stg</sub>	Storage temperature	-55 to 150			°C
T <sub>j</sub>	Max. operating junction temperature	150			°C

- Limited by maximum junction temperature.
- Pulse width limited by safe operating area.
- Pulse width limited by T<sub>j</sub> max.
- Starting T<sub>j</sub> = 25 °C, I<sub>D</sub> = I<sub>AR</sub>, V<sub>DD</sub> = 50 V.
- I<sub>SD</sub> ≤ 5.5 A, di/dt ≤ 400 A/μs, V<sub>DD</sub> = 80% V<sub>(BR)DSS</sub>, V<sub>DSpeak</sub> ≤ V<sub>(BR)DSS</sub>.

**Table 3. Thermal data**

Symbol	Parameter	TO-220FP I <sup>2</sup> PAKFP	I <sup>2</sup> PAK TO-220	IPAK	Unit
R <sub>thj-case</sub>	Thermal resistance junction-case max.	4.17	1.39		°C/W
R <sub>thj-amb</sub>	Thermal resistance junction-ambient max.	62.5		100	°C/W

## 2 Electrical characteristics

( $T_C = 25\text{ °C}$  unless otherwise specified)

**Table 4. On /off states**

Symbol	Parameter	Test conditions	Min.	Typ.	Max.	Unit
$V_{(BR)DSS}$	Drain-source breakdown voltage	$I_D = 1\text{ mA}$ , $V_{GS} = 0$	620			V
$I_{DSS}$	Zero gate voltage drain current ( $V_{GS} = 0$ )	$V_{DS} = 620\text{ V}$ $V_{DS} = 620\text{ V}$ , $T_C = 125\text{ °C}$			0.8 50	$\mu\text{A}$ $\mu\text{A}$
$I_{GSS}$	Gate-body leakage current ( $V_{DS} = 0$ )	$V_{GS} = \pm 20\text{ V}$			$\pm 9$	$\mu\text{A}$
$V_{GS(th)}$	Gate threshold voltage	$V_{DS} = V_{GS}$ , $I_D = 50\text{ }\mu\text{A}$	3	3.75	4.5	V
$R_{DS(on)}$	Static drain-source on resistance	$V_{GS} = 10\text{ V}$ , $I_D = 2.8\text{ A}$		0.95	1.2	$\Omega$

**Table 5. Dynamic**

Symbol	Parameter	Test conditions	Min.	Typ.	Max.	Unit
$C_{iss}$	Input capacitance	$V_{DS} = 50\text{ V}$ , $f = 1\text{ MHz}$ , $V_{GS} = 0$	-	875	-	pF
$C_{oss}$	Output capacitance			100		pF
$C_{rss}$	Reverse transfer capacitance			17		pF
$C_{oss(er)}^{(1)}$	Equivalent output capacitance energy related	$V_{GS} = 0$ , $V_{DS} = 0\text{ to }480\text{ V}$	-	28	-	pF
$C_{oss(tr)}^{(2)}$	Equivalent output capacitance time related			63		pF
$R_G$	Intrinsic gate resistance	$f = 1\text{ MHz}$ open drain	-	3.5	-	$\Omega$
$Q_g$	Total gate charge	$V_{DD} = 496\text{ V}$ , $I_D = 5.5\text{ A}$ , $V_{GS} = 10\text{ V}$ (see <a href="#">Figure 20</a> )	-	34	-	nC
$Q_{gs}$	Gate-source charge			4		nC
$Q_{gd}$	Gate-drain charge			22		nC

1. Is defined as a constant equivalent capacitance giving the same charging time as  $C_{oss}$  when  $V_{DS}$  increases from 0 to 80%  $V_{DSS}$

2. Is defined as a constant equivalent capacitance giving the same storage energy as  $C_{oss}$  when  $V_{DS}$  increases from 0 to 80%  $V_{DSS}$

**Table 6. Switching times**

Symbol	Parameter	Test conditions	Min.	Typ.	Max.	Unit
$t_{d(on)}$	Turn-on delay time	$V_{DD} = 310 \text{ V}$ , $I_D = 2.75 \text{ A}$ , $R_G = 4.7 \Omega$ , $V_{GS} = 10 \text{ V}$ (see <a href="#">Figure 19</a> )		22		ns
$t_r$	Rise time			12		ns
$t_{d(off)}$	Turn-off-delay time			49		ns
$t_f$	Fall time			20		ns

**Table 7. Source drain diode**

Symbol	Parameter	Test conditions	Min.	Typ.	Max.	Unit
$I_{SD}$	Source-drain current				5.5	A
$I_{SDM}^{(1)}$	Source-drain current (pulsed)				27	A
$V_{SD}^{(2)}$	Forward on voltage	$I_{SD} = 5.5 \text{ A}$ , $V_{GS} = 0$			1.5	V
$t_{rr}$	Reverse recovery time	$I_{SD} = 5.5 \text{ A}$ , $di/dt = 100 \text{ A}/\mu\text{s}$ $V_{DD} = 60 \text{ V}$ (see <a href="#">Figure 24</a> )		290		ns
$Q_{rr}$	Reverse recovery charge			1.9		$\mu\text{C}$
$I_{RRM}$	Reverse recovery current			13.5		A
$t_{rr}$	Reverse recovery time	$I_{SD} = 5.5 \text{ A}$ , $di/dt = 100 \text{ A}/\mu\text{s}$ $V_{DD} = 60 \text{ V}$ , $T_j = 150 \text{ }^\circ\text{C}$ (see <a href="#">Figure 24</a> )		335		ns
$Q_{rr}$	Reverse recovery charge			2.4		$\mu\text{C}$
$I_{RRM}$	Reverse recovery current			14.5		A

1. Pulse width limited by safe operating area

2. Pulsed: pulse duration = 300  $\mu\text{s}$ , duty cycle 1.5%

**Table 8. Gate-source Zener diode**

Symbol	Parameter	Test conditions	Min.	Typ.	Max.	Unit
$V_{(BR)GSO}$	Gate-source breakdown voltage ( $I_D = 0$ )	$I_{gs} = \pm 1 \text{ mA}$	30		-	V

The built-in back-to-back Zener diodes have specifically been designed to enhance not only the device's ESD capability, but also to make them safely absorb possible voltage transients that may occasionally be applied from gate to source. In this respect the Zener voltage is appropriate to achieve an efficient and cost-effective intervention to protect the device's integrity. These integrated Zener diodes thus avoid the usage of external components

## 2.1 Electrical characteristics (curves)

Figure 2. Safe operating area for TO-220, I<sup>2</sup>PAK

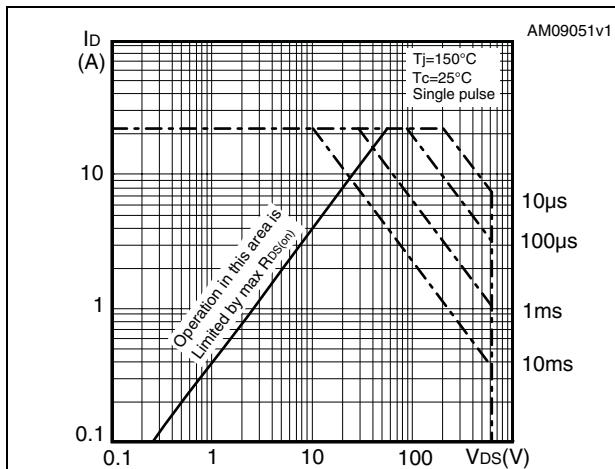

Figure 3. Thermal impedance for TO-220, I<sup>2</sup>PAK

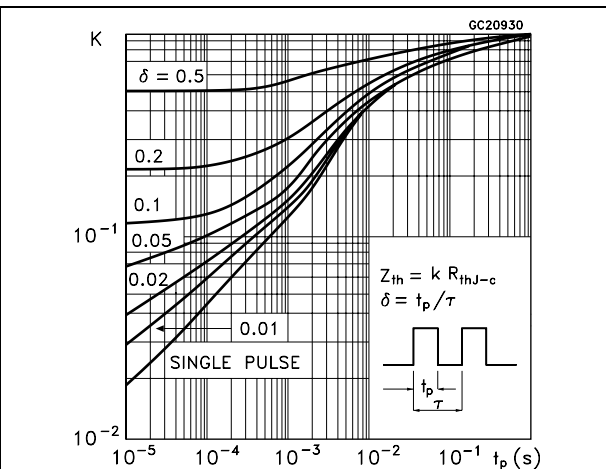

Figure 4. Safe operating area for TO-220FP, I<sup>2</sup>PAKFP

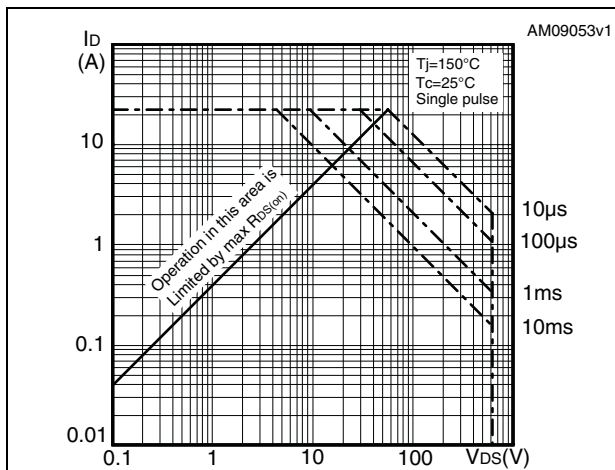

Figure 5. Thermal impedance for TO-220FP, I<sup>2</sup>PAKFP

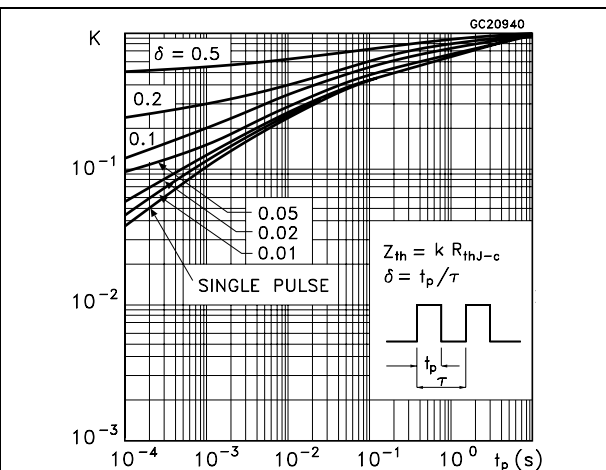

Figure 6. Safe operating area for IPAK

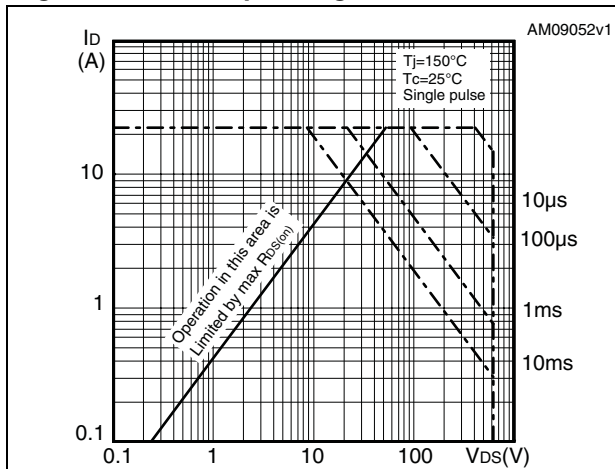

Figure 7. Thermal impedance for IPAK

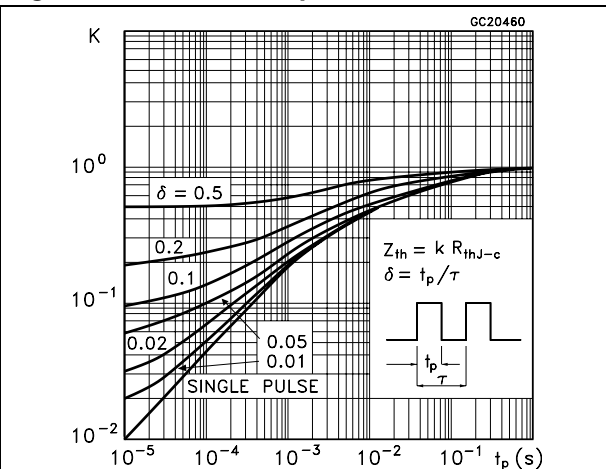

Figure 8. Output characteristics

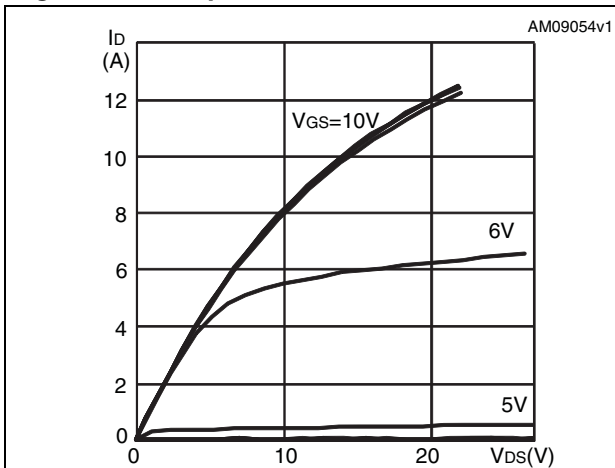

Figure 9. Transfer characteristics

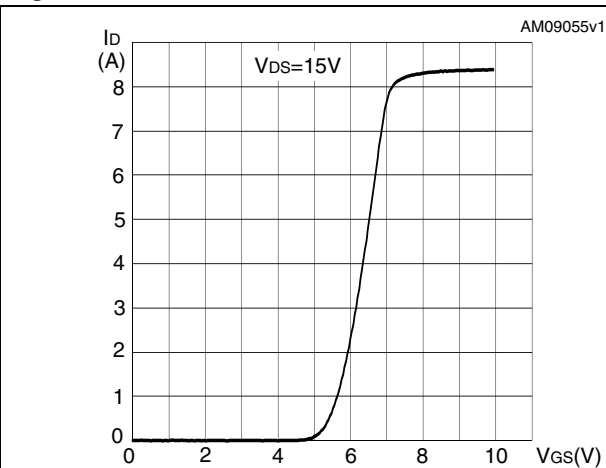

Figure 10. Gate charge vs gate-source voltage Figure 11. Static drain-source on-resistance

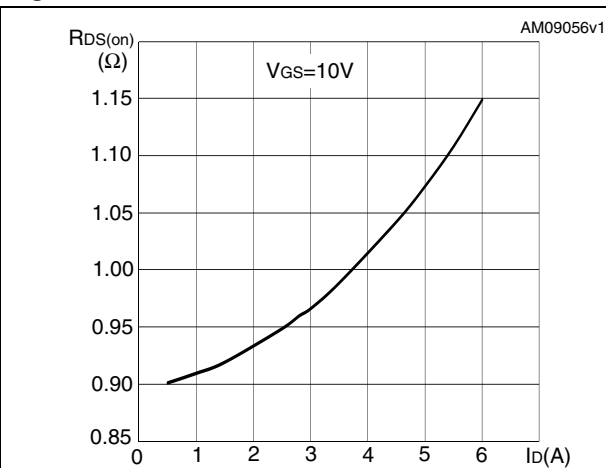
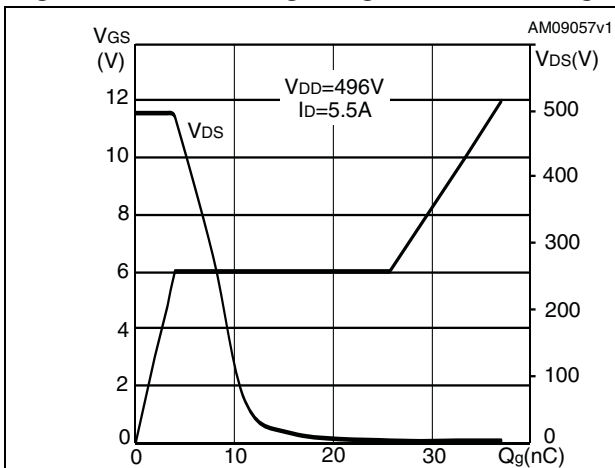

Figure 12. Capacitance variations

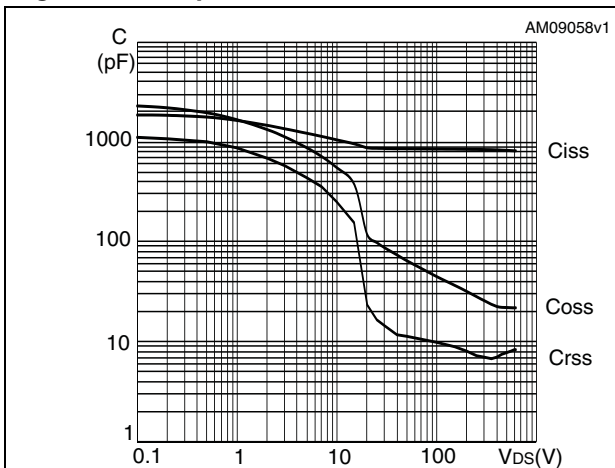

Figure 13. Output capacitance stored energy

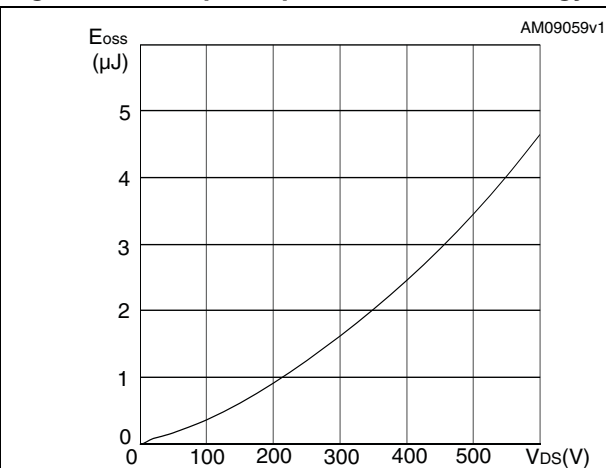

Figure 14. Normalized gate threshold voltage vs temperature

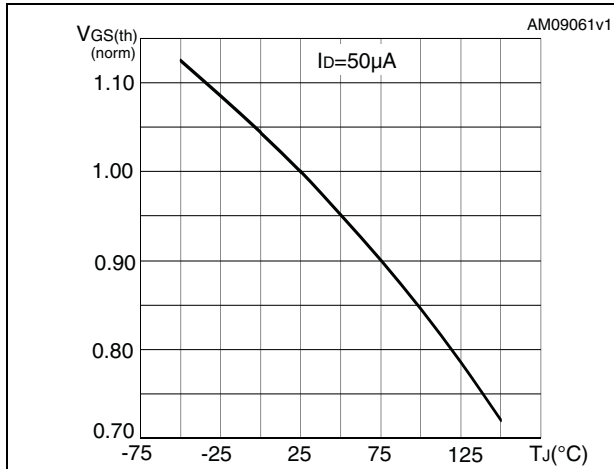

Figure 15. Normalized on-resistance vs temperature

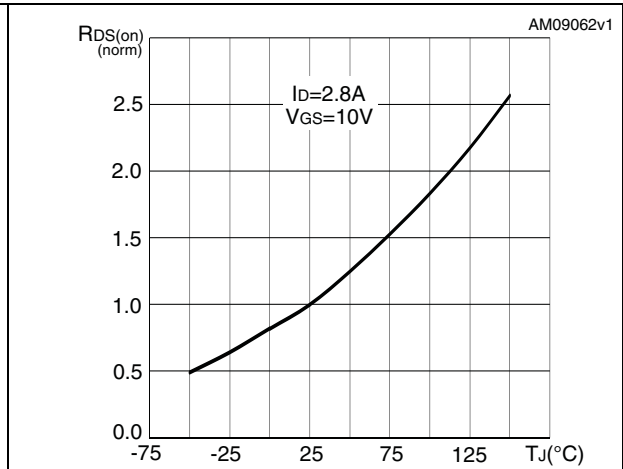

Figure 16. Normalized B<sub>V</sub>DSS vs temperature

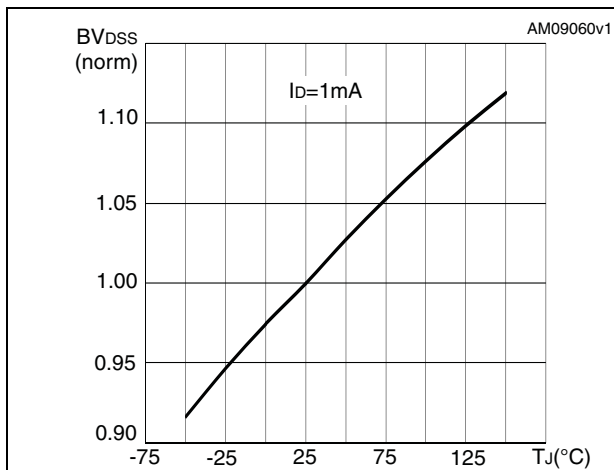

Figure 17. Source-drain diode forward characteristics

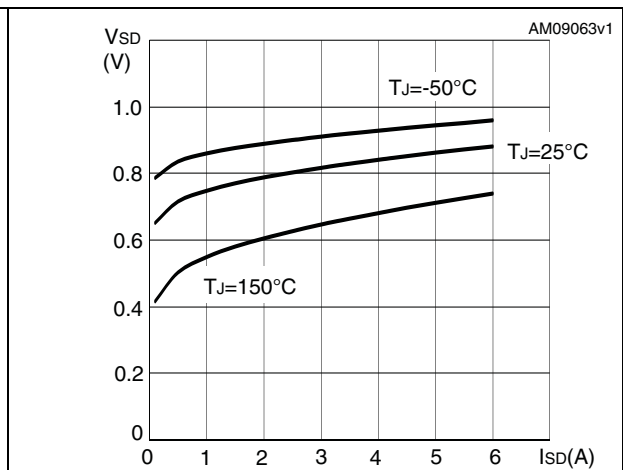
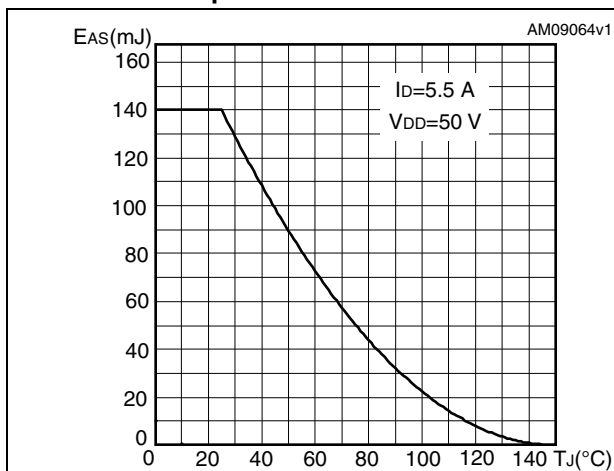
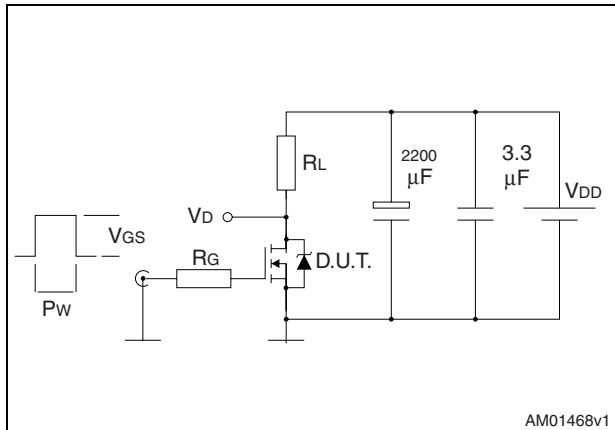

Figure 18. Maximum avalanche energy vs temperature



### 3 Test circuits

**Figure 19. Switching times test circuit for resistive load**



**Figure 20. Gate charge test circuit**

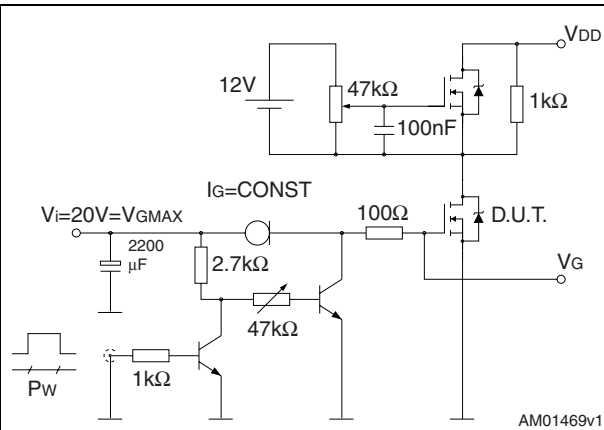

**Figure 21. Test circuit for inductive load switching and diode recovery times**

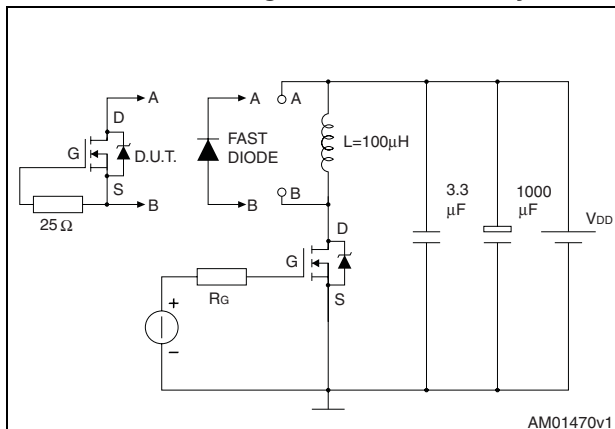

**Figure 22. Unclamped Inductive load test circuit**

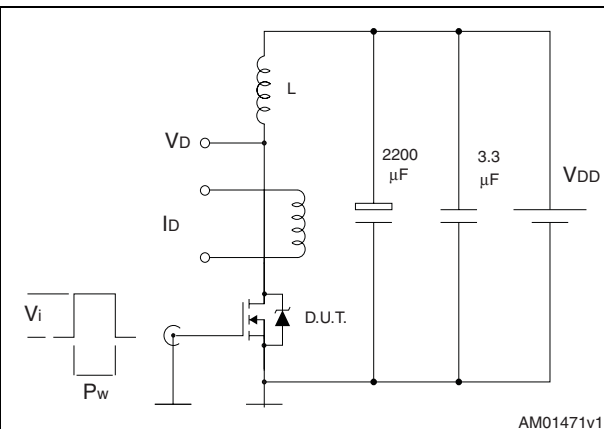

**Figure 23. Unclamped inductive waveform**

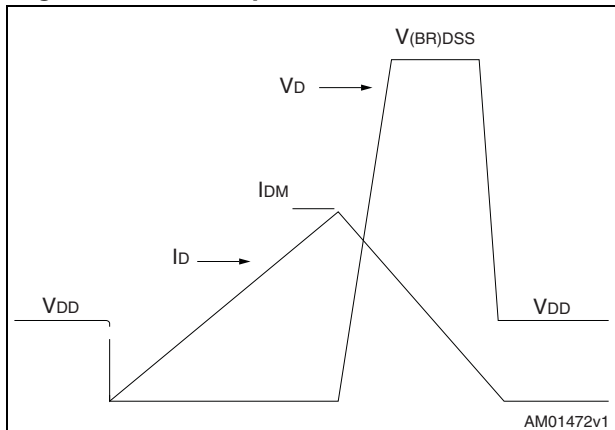

**Figure 24. Switching time waveform**

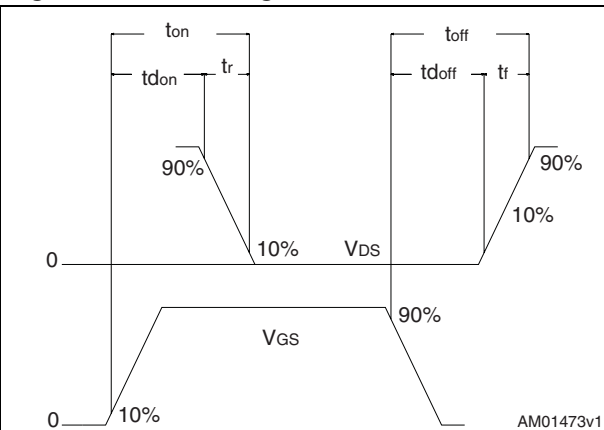

## 4 Package mechanical data

In order to meet environmental requirements, ST offers these devices in different grades of ECOPACK® packages, depending on their level of environmental compliance. ECOPACK® specifications, grade definitions and product status are available at: [www.st.com](http://www.st.com). ECOPACK is an ST trademark.

**Table 9. TO-220FP mechanical data**

Dim.	mm		
	Min.	Typ.	Max.
A	4.4		4.6
B	2.5		2.7
D	2.5		2.75
E	0.45		0.7
F	0.75		1
F1	1.15		1.70
F2	1.15		1.70
G	4.95		5.2
G1	2.4		2.7
H	10		10.4
L2		16	
L3	28.6		30.6
L4	9.8		10.6
L5	2.9		3.6
L6	15.9		16.4
L7	9		9.3
Dia	3		3.2

Figure 25. TO-220FP drawing

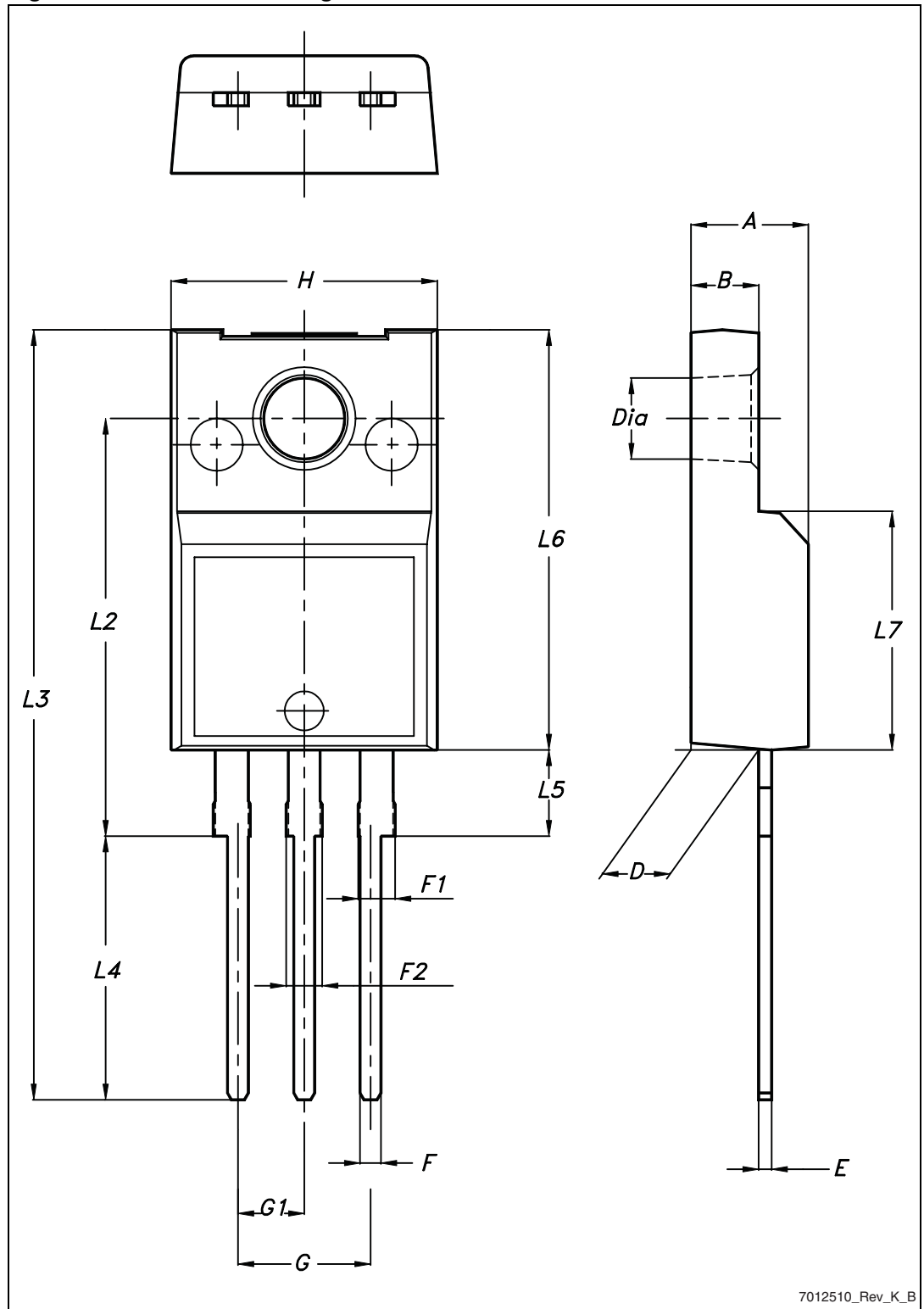

7012510\_Rev\_K\_B

Table 10. I<sup>2</sup>PAKFP (TO-281) mechanical data

Dim.	mm		
	Min.	Typ.	Max.
A	4.40		4.60
B	2.50		2.70
D	2.50		2.75
D1	0.65		0.85
E	0.45		0.70
F	0.75		1.00
F1			1.20
G	4.95	-	5.20
H	10.00		10.40
L1	21.00		23.00
L2	13.20		14.10
L3	10.55		10.85
L4	2.70		3.20
L5	0.85		1.25
L6	7.30		7.50

Figure 26. I<sup>2</sup>PAKFP (TO-281) drawing

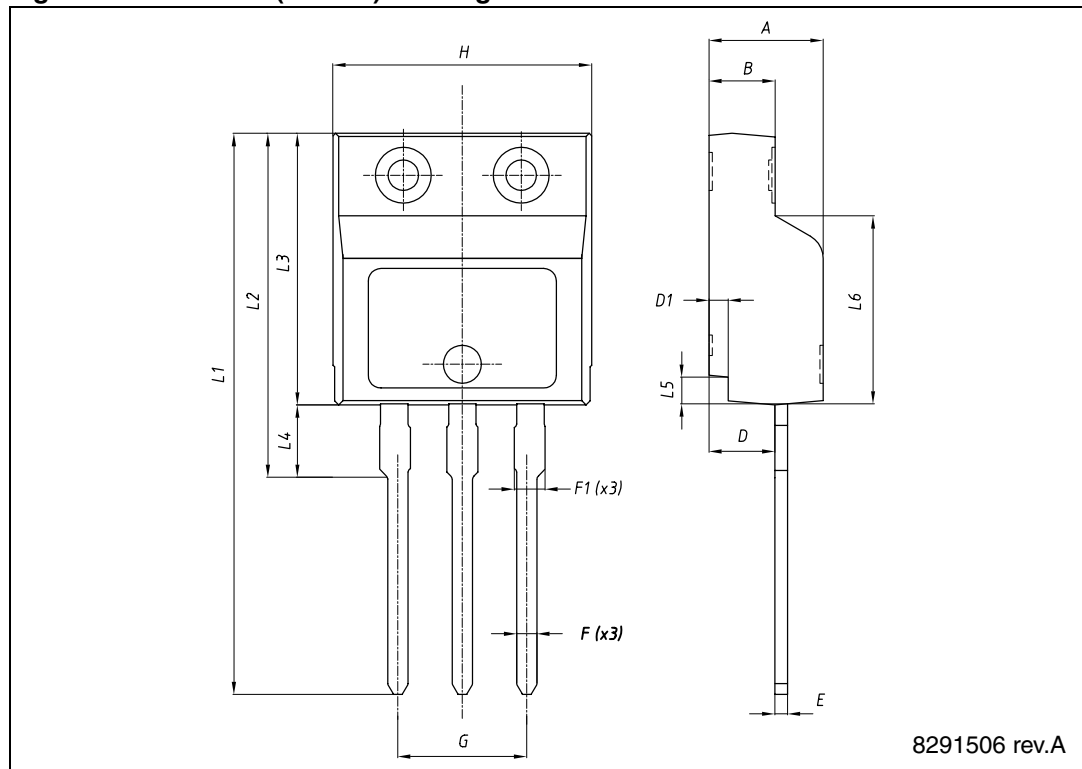

8291506 rev.A

Table 11. I<sup>2</sup>PAK (TO-262) mechanical data

DIM.	mm.		
	min.	typ	max.
A	4.40		4.60
A1	2.40		2.72
b	0.61		0.88
b1	1.14		1.70
c	0.49		0.70
c2	1.23		1.32
D	8.95		9.35
e	2.40		2.70
e1	4.95		5.15
E	10		10.40
L	13		14
L1	3.50		3.93
L2	1.27		1.40

Figure 27. I<sup>2</sup>PAK (TO-262) drawing

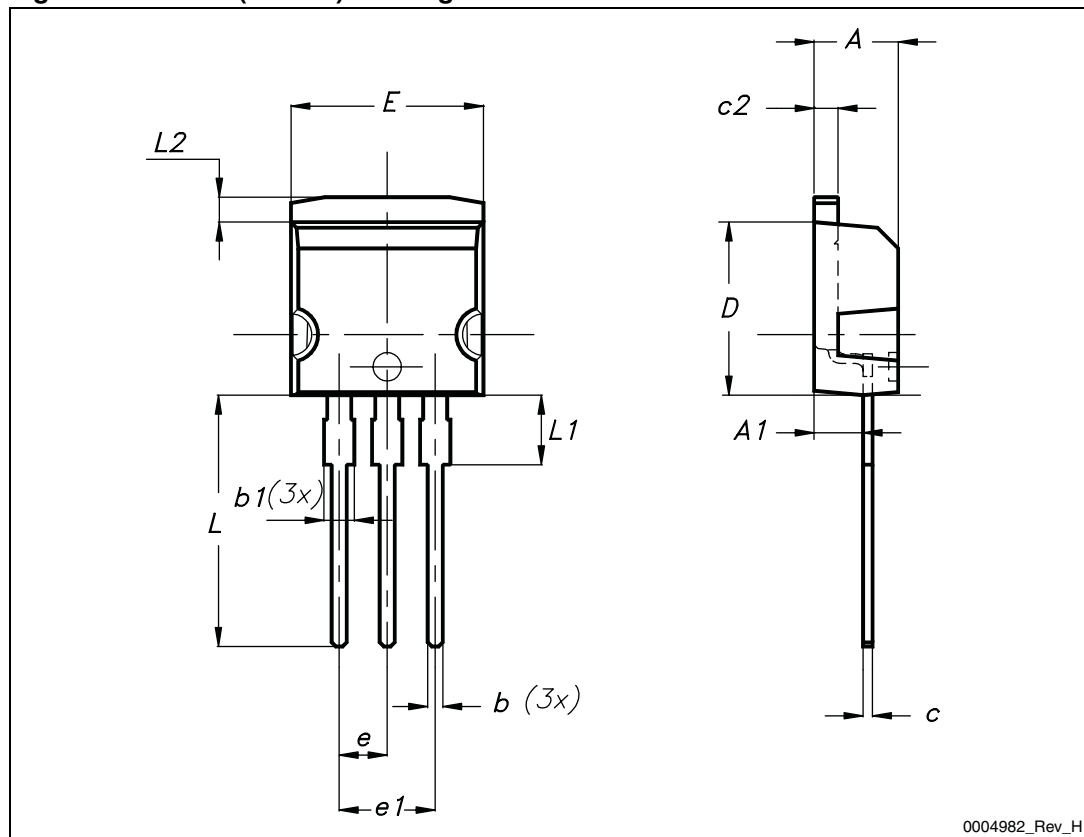

0004982\_Rev\_H

Table 12. TO-220 type A mechanical data

Dim.	mm		
	Min.	Typ.	Max.
A	4.40		4.60
b	0.61		0.88
b1	1.14		1.70
c	0.48		0.70
D	15.25		15.75
D1		1.27	
E	10		10.40
e	2.40		2.70
e1	4.95		5.15
F	1.23		1.32
H1	6.20		6.60
J1	2.40		2.72
L	13		14
L1	3.50		3.93
L20		16.40	
L30		28.90	
ØP	3.75		3.85
Q	2.65		2.95

Figure 28. TO-220 type A drawing

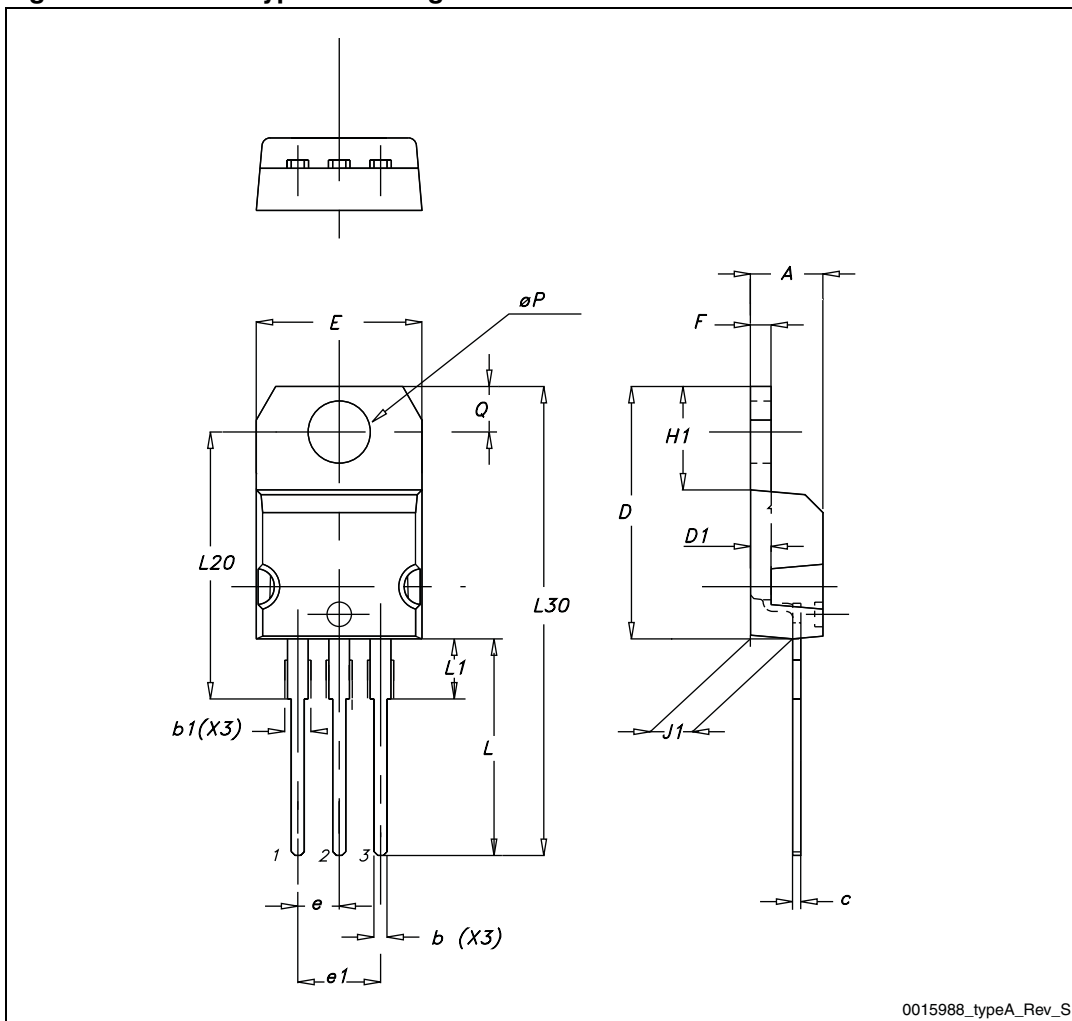

0015988\_typeA\_Rev\_S

Table 13. IPAK (TO-251) mechanical data

DIM	mm.		
	min.	typ.	max.
A	2.20		2.40
A1	0.90		1.10
b	0.64		0.90
b2			0.95
b4	5.20		5.40
B5		0.30	
c	0.45		0.60
c2	0.48		0.60
D	6.00		6.20
E	6.40		6.60
e		2.28	
e1	4.40		4.60
H		16.10	
L	9.00		9.40
L1	0.80		1.20
L2		0.80	1.00
V1		10°	

Figure 29. IPAK (TO-251) drawing

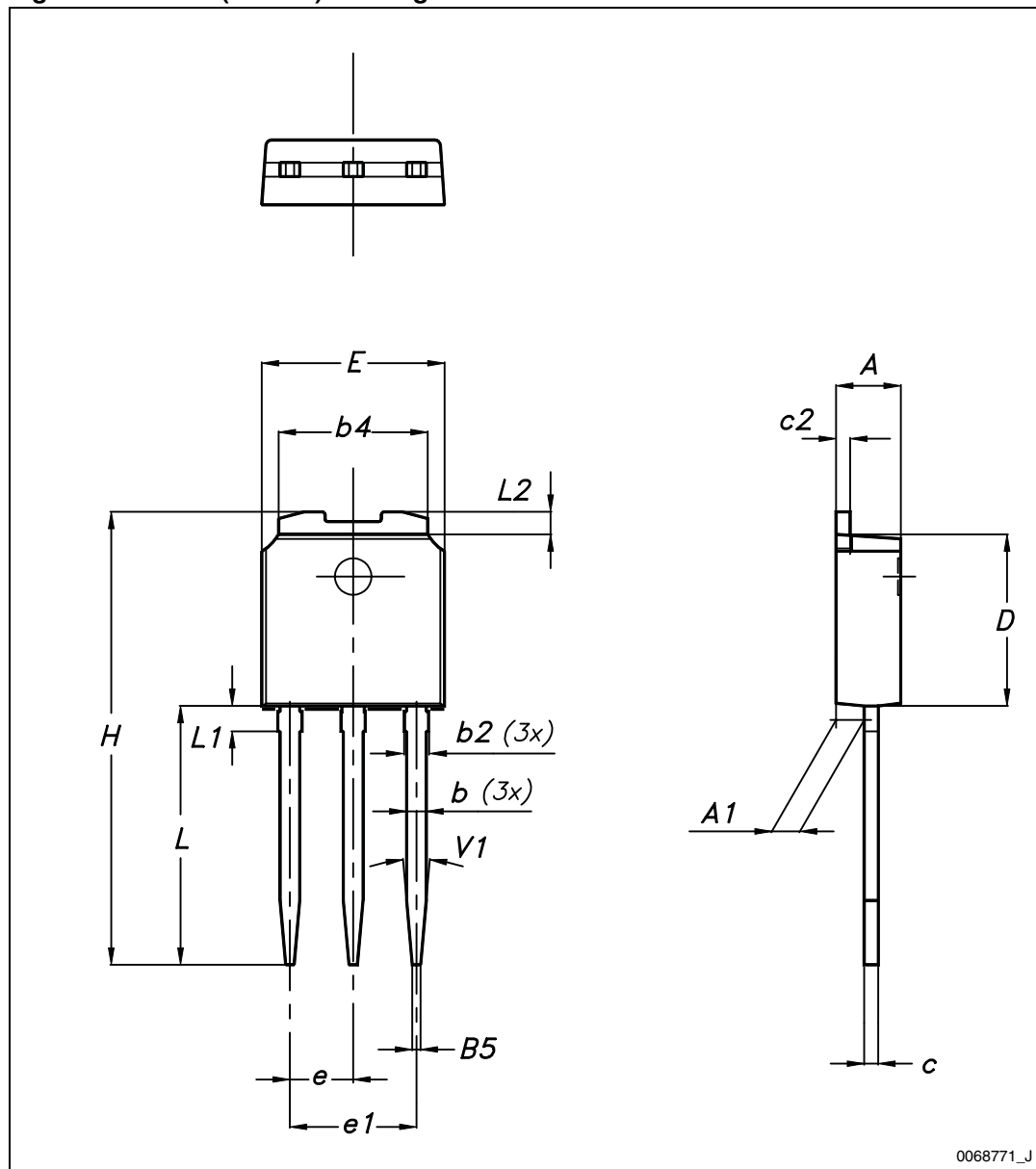

0068771\_J

## 5 Revision history

Table 14. Document revision history

Date	Revision	Changes
19-May-2006	1	First release.
02-May-2011	2	R <sub>G</sub> value has been updated.
06-Dec-2011	3	Removed p/n STD6N62K3 in DPAK.
03-Aug-2012	4	Added package, mechanical data: I <sup>2</sup> PAKFP Updated <a href="#">Table 1: Device summary</a> , <a href="#">Table 2: Absolute maximum ratings</a> , <a href="#">Table 3: Thermal data</a> , <a href="#">Table 4: On /off states</a> , <a href="#">Table 13: IPAK (TO-251) mechanical data</a> and <a href="#">Figure 29: IPAK (TO-251) drawing</a> Minor text changes.

**Please Read Carefully:**

Information in this document is provided solely in connection with ST products. STMicroelectronics NV and its subsidiaries ("ST") reserve the right to make changes, corrections, modifications or improvements, to this document, and the products and services described herein at any time, without notice.

All ST products are sold pursuant to ST's terms and conditions of sale.

Purchasers are solely responsible for the choice, selection and use of the ST products and services described herein, and ST assumes no liability whatsoever relating to the choice, selection or use of the ST products and services described herein.

No license, express or implied, by estoppel or otherwise, to any intellectual property rights is granted under this document. If any part of this document refers to any third party products or services it shall not be deemed a license grant by ST for the use of such third party products or services, or any intellectual property contained therein or considered as a warranty covering the use in any manner whatsoever of such third party products or services or any intellectual property contained therein.

**UNLESS OTHERWISE SET FORTH IN ST'S TERMS AND CONDITIONS OF SALE ST DISCLAIMS ANY EXPRESS OR IMPLIED WARRANTY WITH RESPECT TO THE USE AND/OR SALE OF ST PRODUCTS INCLUDING WITHOUT LIMITATION IMPLIED WARRANTIES OF MERCHANTABILITY, FITNESS FOR A PARTICULAR PURPOSE (AND THEIR EQUIVALENTS UNDER THE LAWS OF ANY JURISDICTION), OR INFRINGEMENT OF ANY PATENT, COPYRIGHT OR OTHER INTELLECTUAL PROPERTY RIGHT.**

**UNLESS EXPRESSLY APPROVED IN WRITING BY TWO AUTHORIZED ST REPRESENTATIVES, ST PRODUCTS ARE NOT RECOMMENDED, AUTHORIZED OR WARRANTED FOR USE IN MILITARY, AIR CRAFT, SPACE, LIFE SAVING, OR LIFE SUSTAINING APPLICATIONS, NOR IN PRODUCTS OR SYSTEMS WHERE FAILURE OR MALFUNCTION MAY RESULT IN PERSONAL INJURY, DEATH, OR SEVERE PROPERTY OR ENVIRONMENTAL DAMAGE. ST PRODUCTS WHICH ARE NOT SPECIFIED AS "AUTOMOTIVE GRADE" MAY ONLY BE USED IN AUTOMOTIVE APPLICATIONS AT USER'S OWN RISK.**

Resale of ST products with provisions different from the statements and/or technical features set forth in this document shall immediately void any warranty granted by ST for the ST product or service described herein and shall not create or extend in any manner whatsoever, any liability of ST.

ST and the ST logo are trademarks or registered trademarks of ST in various countries.

Information in this document supersedes and replaces all information previously supplied.

The ST logo is a registered trademark of STMicroelectronics. All other names are the property of their respective owners.

© 2012 STMicroelectronics - All rights reserved

STMicroelectronics group of companies



Australia - Belgium - Brazil - Canada - China - Czech Republic - Finland - France - Germany - Hong Kong - India - Israel - Italy - Japan - Malaysia - Malta - Morocco - Philippines - Singapore - Spain - Sweden - Switzerland - United Kingdom - United States of America

[www.st.com](http://www.st.com)



## Looking for pricing, stock, or lifecycle information?

Click below to explore more details on WIN SOURCE:

-  [View STF6N62K3 on WIN SOURCE](#)
-  [STMicroelectronics Information](#)

## Optimize Your Supply Chain with WIN SOURCE Solutions

-  Global Sourcing Solution
-  Obsolete Management
-  Cost Control Management
-  Shortage Management
-  Alternative Solution
-  Excess Inventory Management