



# THE DATASHEET OF STF6N65K3





# STF6N65K3, STFI6N65K3, STU6N65K3

N-channel 650 V, 1.1  $\Omega$  typ., 5.4 A SuperMESH3™ Power MOSFET in TO-220FP, I<sup>2</sup>PAKFP, IPAK

Datasheet — production data

## Features

Order codes	V <sub>DSS</sub>	R <sub>DS(on)</sub> max.	I <sub>D</sub>	P <sub>tot</sub>
STF6N65K3	650 V	< 1.3 $\Omega$	5.4 A	30 W
STFI6N65K3				110 W
STU6N65K3				

- 100% avalanche tested
- Extremely high dv/dt capability
- Gate charge minimized
- Very low intrinsic capacitance
- Improved diode reverse recovery characteristics
- Zener-protected

## Applications

- Switching applications

## Description

These SuperMESH3™ Power MOSFETs are the result of improvements applied to STMicroelectronics' SuperMESH™ technology, combined with a new optimized vertical structure. These devices boast an extremely low on-resistance, superior dynamic performance and high avalanche capability, rendering them suitable for the most demanding applications.

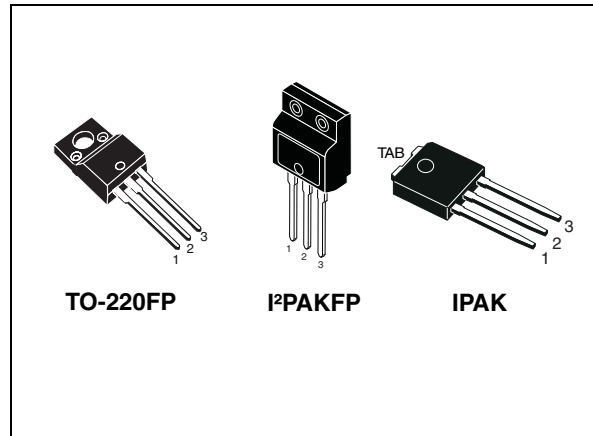
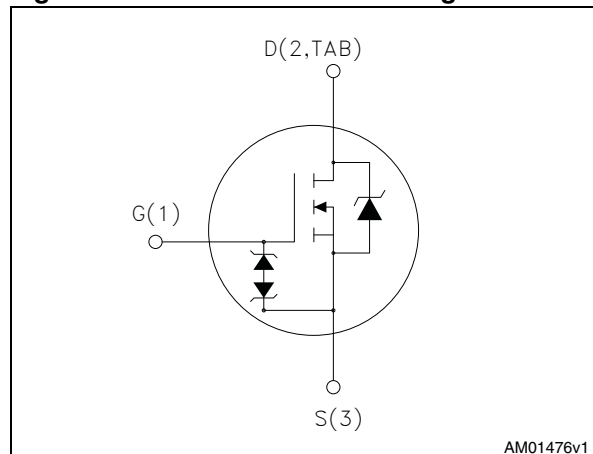

Figure 1. Internal schematic diagram



AM01476v1

Table 1. Device summary

Order codes	Marking	Package	Packaging
STF6N65K3	6N65K3	TO-220FP	Tube
STFI6N65K3		I <sup>2</sup> PAKFP	
STU6N65K3		IPAK	

# Contents

<b>1</b>	<b>Electrical ratings</b> .....	<b>3</b>
<b>2</b>	<b>Electrical characteristics</b> .....	<b>4</b>
2.1	Electrical characteristics (curves) .....	6
<b>3</b>	<b>Test circuits</b> .....	<b>9</b>
<b>4</b>	<b>Package mechanical data</b> .....	<b>10</b>
<b>5</b>	<b>Revision history</b> .....	<b>15</b>

# 1 Electrical ratings

**Table 2. Absolute maximum ratings**

Symbol	Parameter	Value			Unit
		TO-220FP	I <sup>2</sup> PAKFP	I <sup>2</sup> PAK	
V <sub>DS</sub>	Drain-source voltage	650			V
V <sub>GS</sub>	Gate- source voltage	± 30			V
I <sub>D</sub>	Drain current (continuous) at T <sub>C</sub> = 25 °C	5.4 <sup>(1)</sup>	5.4		A
I <sub>D</sub>	Drain current (continuous) at T <sub>C</sub> = 100 °C	3 <sup>(1)</sup>	3		A
I <sub>DM</sub> <sup>(2)</sup>	Drain current (pulsed)	21.6 <sup>(1)</sup>	21.6		A
P <sub>TOT</sub>	Total dissipation at T <sub>C</sub> = 25 °C	30	110		W
I <sub>AR</sub>	Avalanche current, repetitive or not-repetitive (pulse width limited by T <sub>j</sub> max)	5.4			A
E <sub>AS</sub>	Single pulse avalanche energy (starting T <sub>j</sub> = 25 °C, I <sub>D</sub> = I <sub>AR</sub> , V <sub>DD</sub> = 50 V)	100			mJ
ESD	Gate-source human body model (C = 100 pF, R = 1.5 kΩ)	2.5			kV
dv/dt <sup>(3)</sup>	Peak diode recovery voltage slope	12			V/ns
V <sub>ISO</sub>	Insulation withstand voltage (RMS) from all three leads to external heat sink (t = 1 s; T <sub>C</sub> = 25 °C)	2500			V
T <sub>stg</sub>	Storage temperature	-55 to 150			°C
T <sub>j</sub>	Max. operating junction temperature	150			°C

- Limited by package
- Pulse width limited by safe operating area
- I<sub>SD</sub> ≤ 5.4 A, di/dt ≤ 400 A/μs, V<sub>DD</sub> = 80% V<sub>(BR)DSS</sub>

**Table 3. Thermal data**

Symbol	Parameter	Value			Unit
		TO-220FP	I <sup>2</sup> PAKFP	I <sup>2</sup> PAK	
R <sub>thj-case</sub>	Thermal resistance junction-case max	4.17	1.14		°C/W
R <sub>thj-amb</sub>	Thermal resistance junction-ambient max	62.5	100		°C/W

## 2 Electrical characteristics

( $T_C = 25\text{ °C}$  unless otherwise specified)

**Table 4. On /off states**

Symbol	Parameter	Test conditions	Min.	Typ.	Max.	Unit
$V_{(BR)DSS}$	Drain-source breakdown voltage	$I_D = 1\text{ mA}$ , $V_{GS} = 0$	650			V
$I_{DSS}$	Zero gate voltage drain current ( $V_{GS} = 0$ )	$V_{DS} = 650\text{ V}$ $V_{DS} = 650\text{ V}$ , $T_C = 125\text{ °C}$			0.8 50	$\mu\text{A}$ $\mu\text{A}$
$I_{GSS}$	Gate-body leakage current ( $V_{DS} = 0$ )	$V_{GS} = \pm 20\text{ V}$			$\pm 9$	$\mu\text{A}$
$V_{GS(th)}$	Gate threshold voltage	$V_{DS} = V_{GS}$ , $I_D = 50\text{ }\mu\text{A}$	3	3.75	4.5	V
$R_{DS(on)}$	Static drain-source on-resistance	$V_{GS} = 10\text{ V}$ , $I_D = 2.7\text{ A}$		1.1	1.3	$\Omega$

**Table 5. Dynamic**

Symbol	Parameter	Test conditions	Min.	Typ.	Max.	Unit
$C_{iss}$	Input capacitance	$V_{DS} = 50\text{ V}$ , $f = 1\text{ MHz}$ , $V_{GS} = 0$	-	880	-	pF
$C_{oss}$	Output capacitance			65		pF
$C_{rss}$	Reverse transfer capacitance			12		pF
$C_{o(tr)}^{(1)}$	Eq. capacitance time related	$V_{GS} = 0$ , $V_{DS} = 0\text{ to }520\text{ V}$	-	43	-	pF
$C_{o(er)}^{(2)}$	Eq. capacitance energy related			27		pF
$R_G$	Intrinsic gate resistance	$f = 1\text{ MHz}$ open drain	-	3.5	-	$\Omega$
$Q_g$	Total gate charge	$V_{DD} = 500\text{ V}$ , $I_D = 5.4\text{ A}$ , $V_{GS} = 10\text{ V}$ (see <a href="#">Figure 18</a> )	-	33	-	nC
$Q_{gs}$	Gate-source charge			4		nC
$Q_{gd}$	Gate-drain charge			21		nC

- $C_{oss\text{ eq}}$ : time related is defined as a constant equivalent capacitance giving the same charging time as  $C_{oss}$  when  $V_{DS}$  increases from 0 to 80%  $V_{DSS}$
- $C_{oss\text{ eq}}$ : energy related is defined as a constant equivalent capacitance giving the same stored energy as  $C_{oss}$  when  $V_{DS}$  increases from 0 to 80%  $V_{DSS}$

**Table 6. Switching times**

Symbol	Parameter	Test conditions	Min.	Typ.	Max.	Unit	
$t_{d(on)}$	Turn-on delay time	$V_{DD} = 325\text{ V}$ , $I_D = 2.7\text{ A}$ , $R_G = 4.7\ \Omega$ , $V_{GS} = 10\text{ V}$ (see <a href="#">Figure 17</a> )		14		ns	
$t_r$	Rise time			10		ns	
$t_{d(off)}$	Turn-off-delay time				44		ns
$t_f$	Fall time				24		ns

**Table 7. Source drain diode**

Symbol	Parameter	Test conditions	Min.	Typ.	Max.	Unit	
$I_{SD}$	Source-drain current				5.4	A	
$I_{SDM}^{(1)}$	Source-drain current (pulsed)				21.6	A	
$V_{SD}^{(2)}$	Forward on voltage	$I_{SD} = 5.4\text{ A}$ , $V_{GS} = 0$			1.5	V	
$t_{rr}$	Reverse recovery time	$I_{SD} = 5.4\text{ A}$ , $di/dt = 100\text{ A}/\mu\text{s}$ $V_{DD} = 60\text{ V}$ (see <a href="#">Figure 22</a> )		285		ns	
$Q_{rr}$	Reverse recovery charge				5100		nC
$I_{RRM}$	Reverse recovery current				14		A
$t_{rr}$	Reverse recovery time	$I_{SD} = 5.4\text{ A}$ , $di/dt = 100\text{ A}/\mu\text{s}$ $V_{DD} = 60\text{ V}$ , $T_j = 150\text{ }^\circ\text{C}$ (see <a href="#">Figure 22</a> )		330		ns	
$Q_{rr}$	Reverse recovery charge				2500		nC
$I_{RRM}$	Reverse recovery current				15.5		A

1. Pulse width limited by safe operating area

2. Pulsed: Pulse duration = 300  $\mu\text{s}$ , duty cycle 1.5%

**Table 8. Gate-source Zener diode**

Symbol	Parameter	Test conditions	Min.	Typ.	Max.	Unit
$V_{(BR)GSO}$	Gate-source breakdown voltage	$I_{GS} = \pm 1\text{ mA}$ , $I_D = 0$ (open drain)	30		-	V

The built-in back-to-back Zener diodes have specifically been designed to enhance not only the device's ESD capability, but also to make them safely absorb possible voltage transients that may occasionally be applied from gate to source. In this respect the Zener voltage is appropriate to achieve an efficient and cost-effective intervention to protect the device's integrity. These integrated Zener diodes thus avoid the usage of external components

## 2.1 Electrical characteristics (curves)

Figure 2. Safe operating area for TO-220FP and I<sup>2</sup>PAKFP

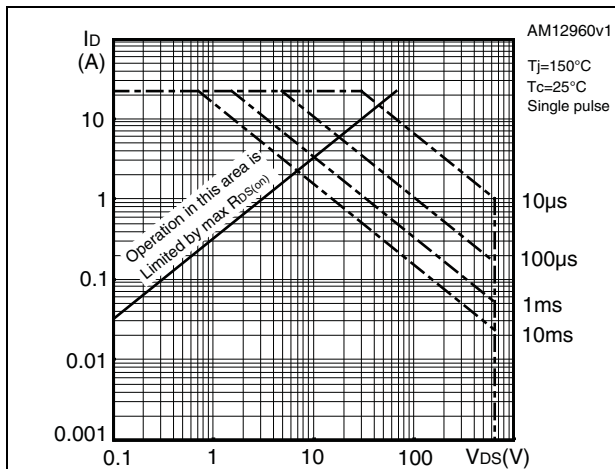

Figure 3. Thermal impedance for TO-220FP and I<sup>2</sup>PAKFP

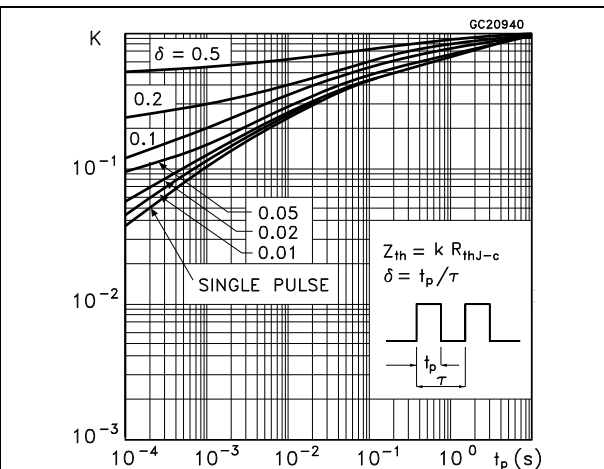

Figure 4. Safe operating area for IPAK

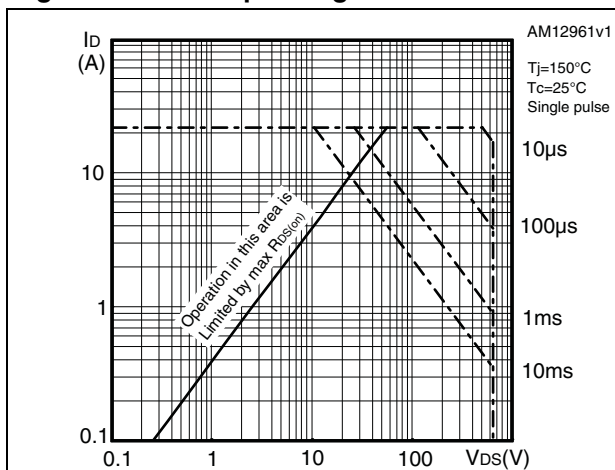

Figure 5. Thermal impedance for IPAK

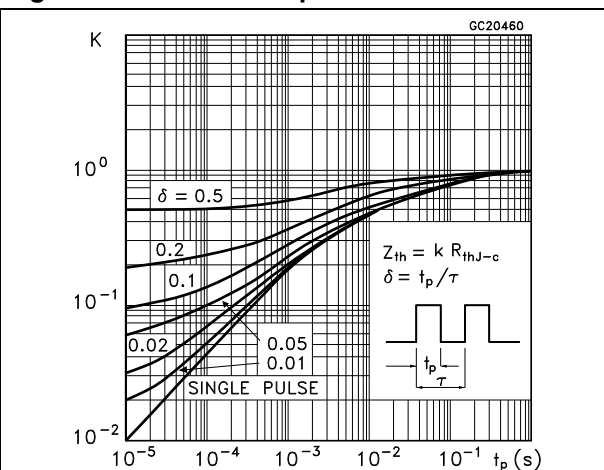

Figure 6. Output characteristics

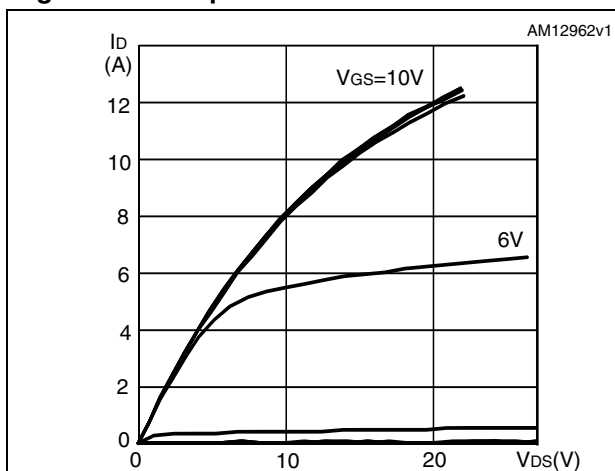
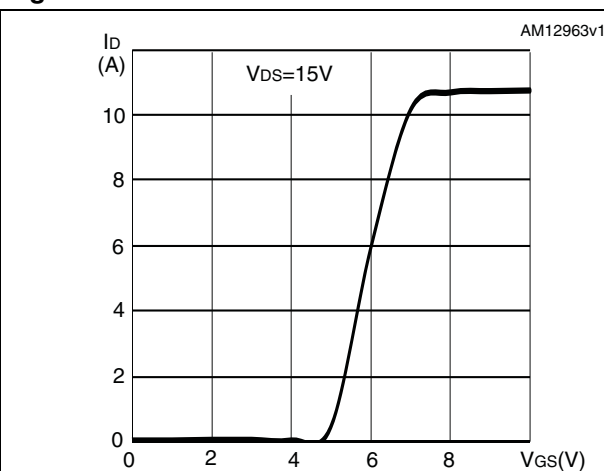
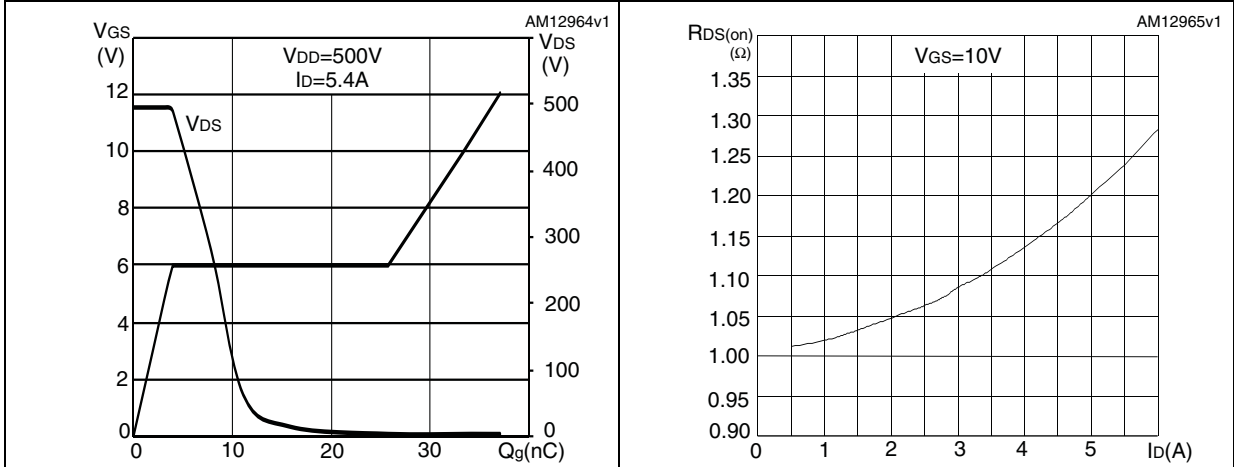

Figure 7. Transfer characteristics



**Figure 8. Gate charge vs gate-source voltage** **Figure 9. Static drain-source on-resistance**



**Figure 10. Capacitance variations** **Figure 11. Output capacitance stored energy**

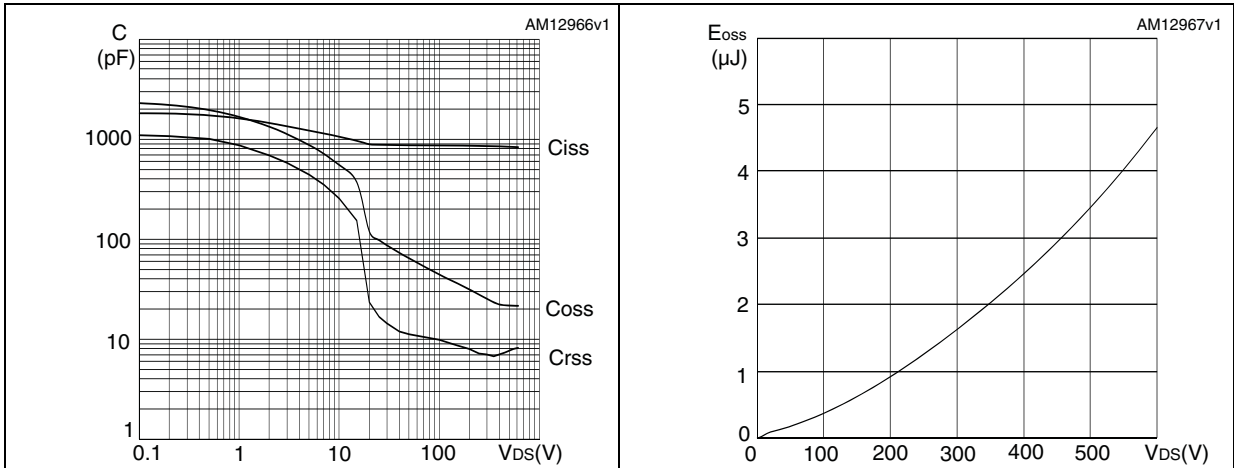

**Figure 12. Normalized gate threshold voltage vs temperature** **Figure 13. Normalized on-resistance vs temperature**

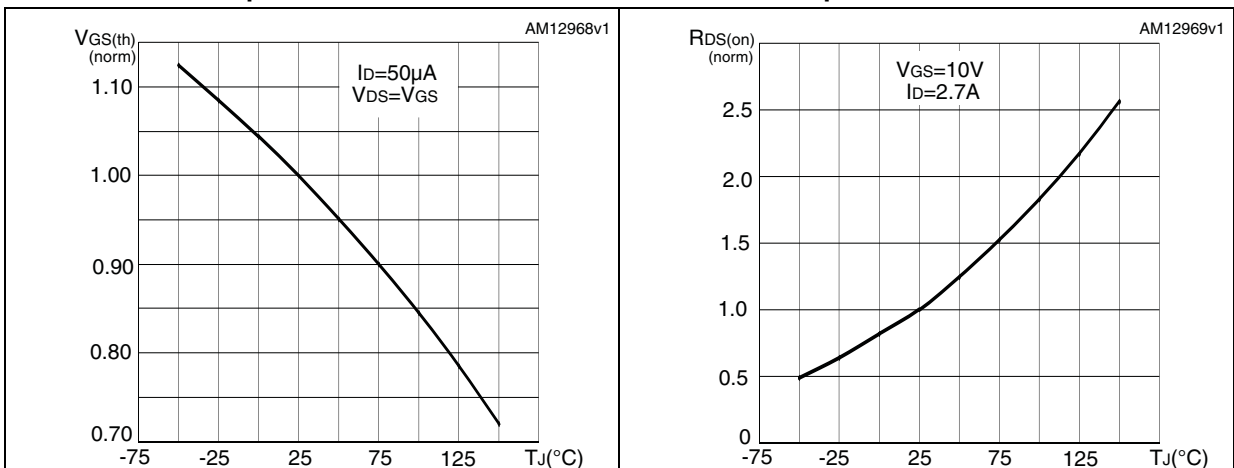

Figure 14. Normalized  $BV_{DSS}$  vs temperature

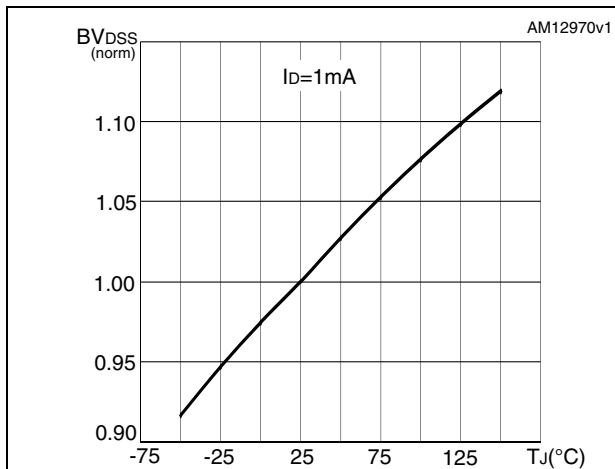

Figure 15. Source-drain diode forward characteristics

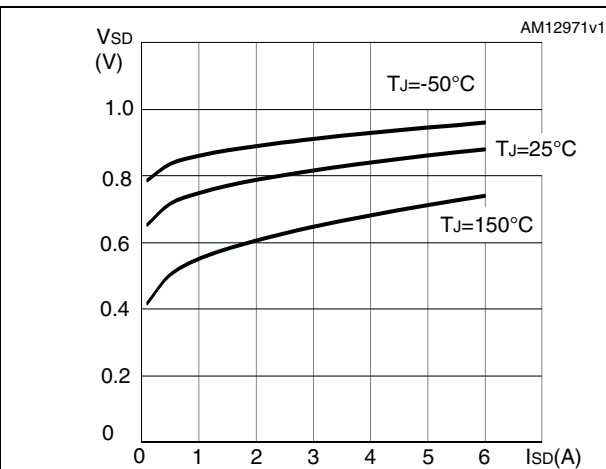
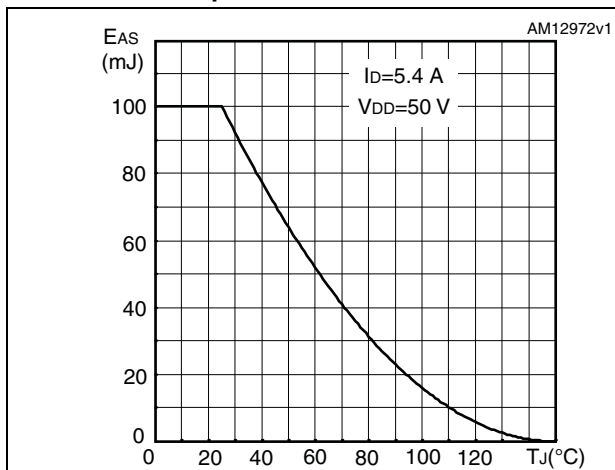
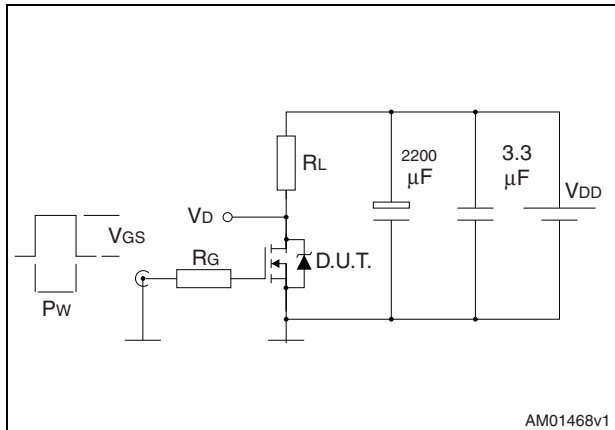

Figure 16. Maximum avalanche energy vs temperature



### 3 Test circuits

**Figure 17. Switching times test circuit for resistive load**



AM01468v1

**Figure 18. Gate charge test circuit**

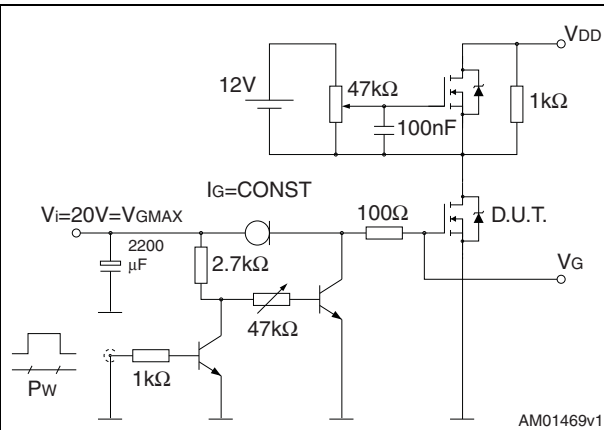

AM01469v1

**Figure 19. Test circuit for inductive load switching and diode recovery times**

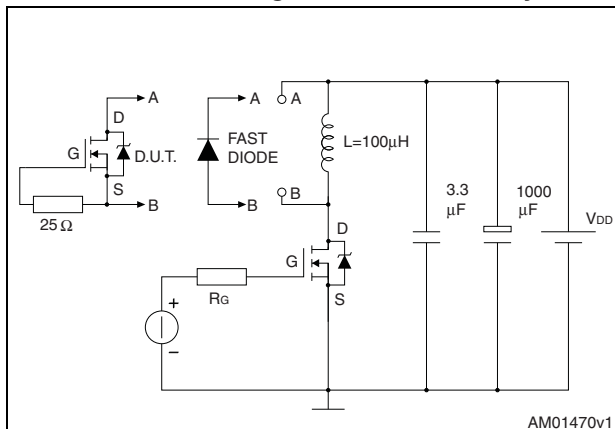

AM01470v1

**Figure 20. Unclamped inductive load test circuit**

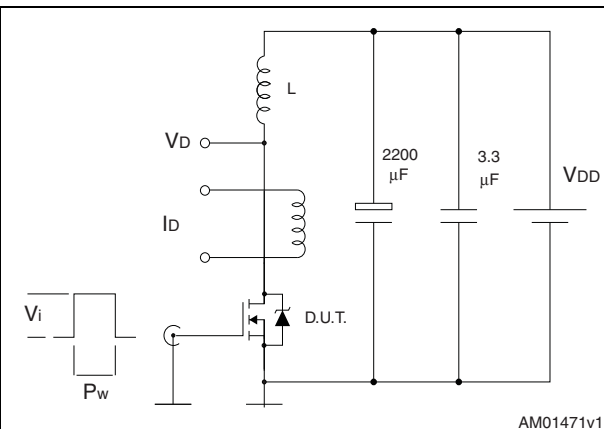

AM01471v1

**Figure 21. Unclamped inductive waveform**

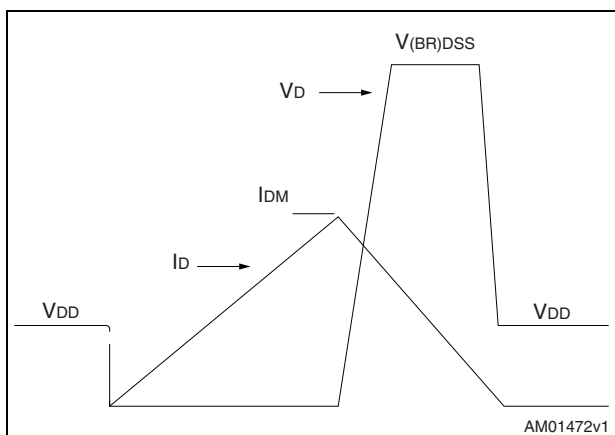

AM01472v1

**Figure 22. Switching time waveform**

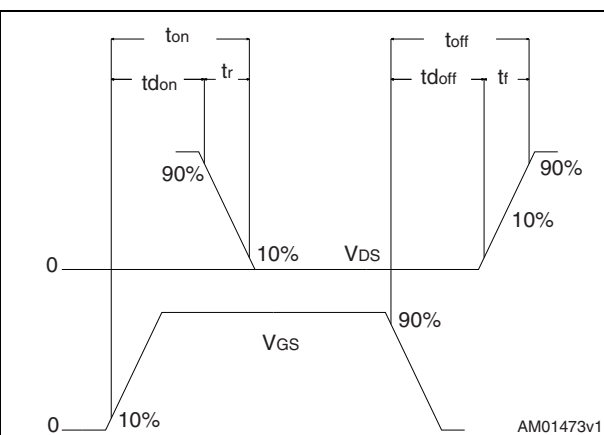

AM01473v1

## 4 Package mechanical data

In order to meet environmental requirements, ST offers these devices in different grades of ECOPACK® packages, depending on their level of environmental compliance. ECOPACK® specifications, grade definitions and product status are available at: [www.st.com](http://www.st.com). ECOPACK is an ST trademark.

**Table 9. TO-220FP mechanical data**

Dim.	mm		
	Min.	Typ.	Max.
A	4.4		4.6
B	2.5		2.7
D	2.5		2.75
E	0.45		0.7
F	0.75		1
F1	1.15		1.70
F2	1.15		1.70
G	4.95		5.2
G1	2.4		2.7
H	10		10.4
L2		16	
L3	28.6		30.6
L4	9.8		10.6
L5	2.9		3.6
L6	15.9		16.4
L7	9		9.3
Dia	3		3.2

Figure 23. TO-220FP drawing

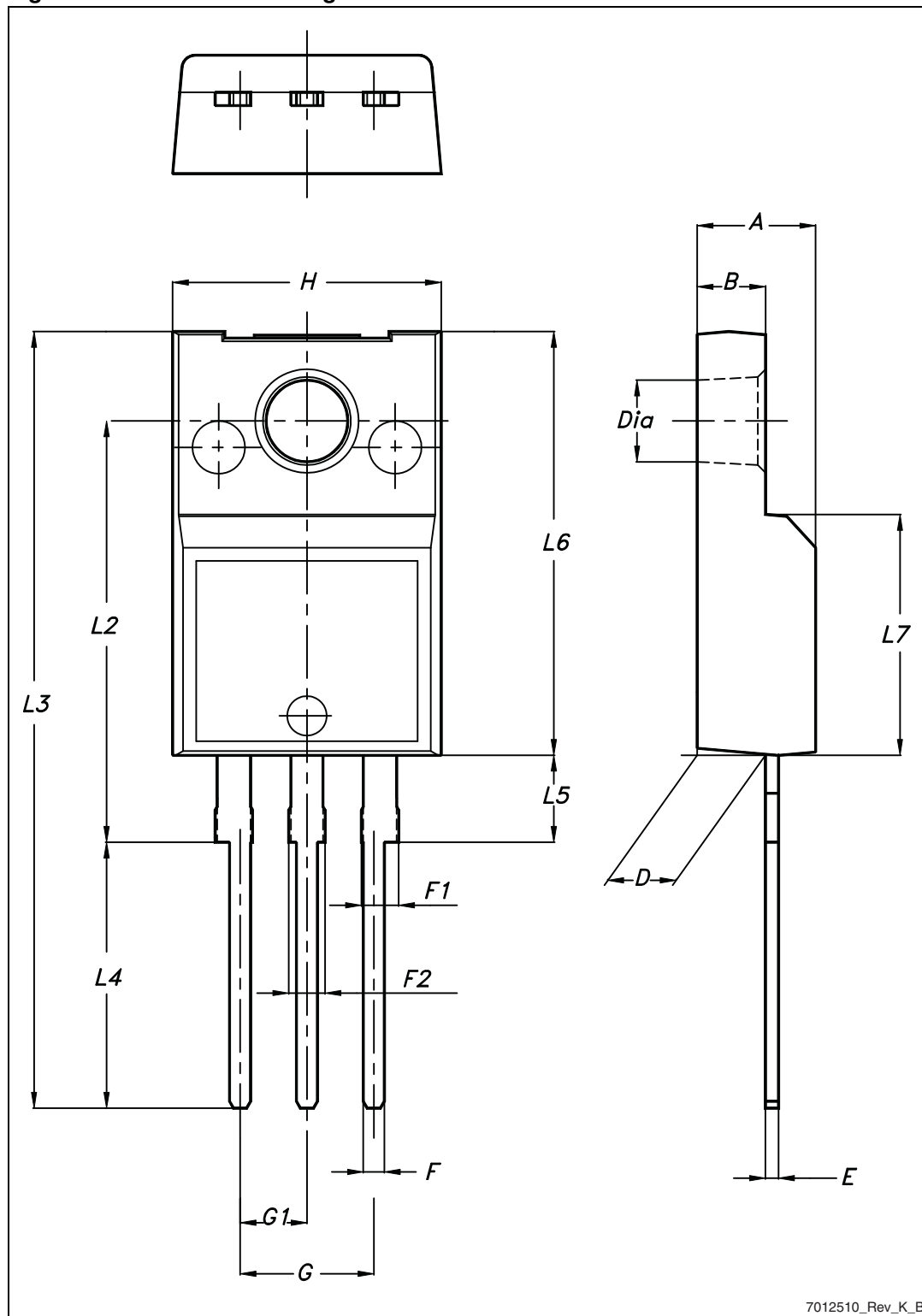

7012510\_Rev\_K\_B

Table 10. I<sup>2</sup>PAKFP (TO-281) mechanical data

Dim.	mm		
	Min.	Typ.	Max.
A	4.40		4.60
B	2.50		2.70
D	2.50		2.75
D1	0.65		0.85
E	0.45		0.70
F	0.75		1.00
F1			1.20
G	4.95	-	5.20
H	10.00		10.40
L1	21.00		23.00
L2	13.20		14.10
L3	10.55		10.85
L4	2.70		3.20
L5	0.85		1.25
L6	7.30		7.50

Figure 24. I<sup>2</sup>PAKFP (TO-281) drawing

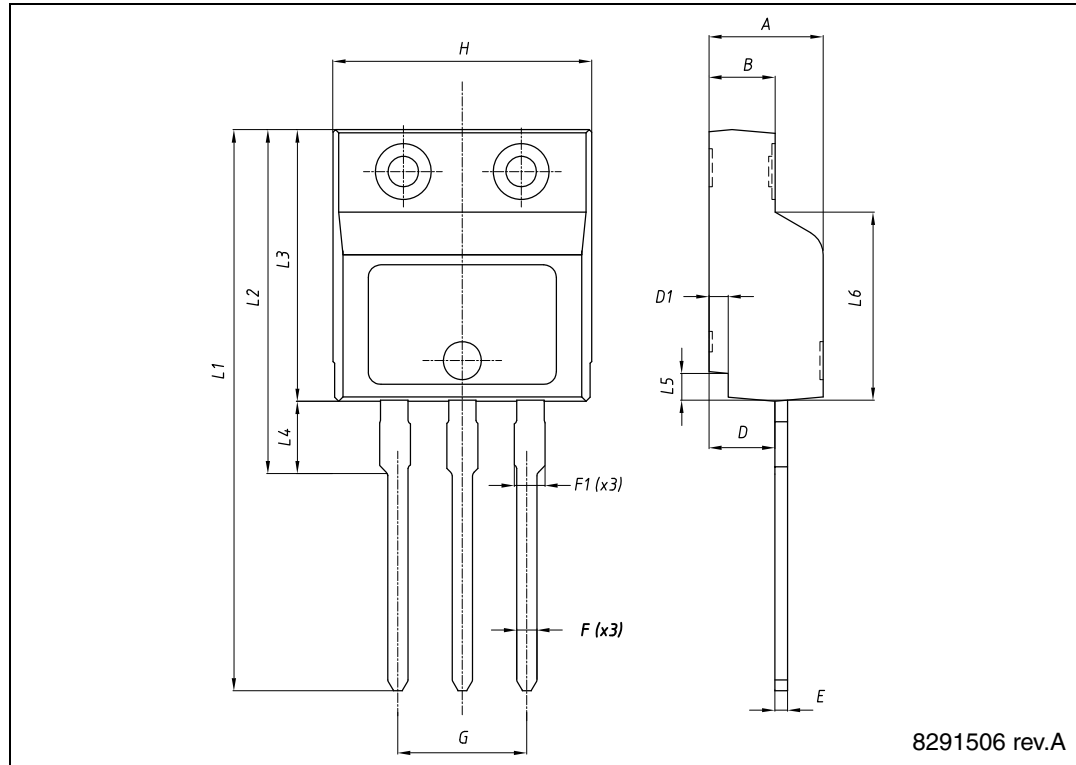
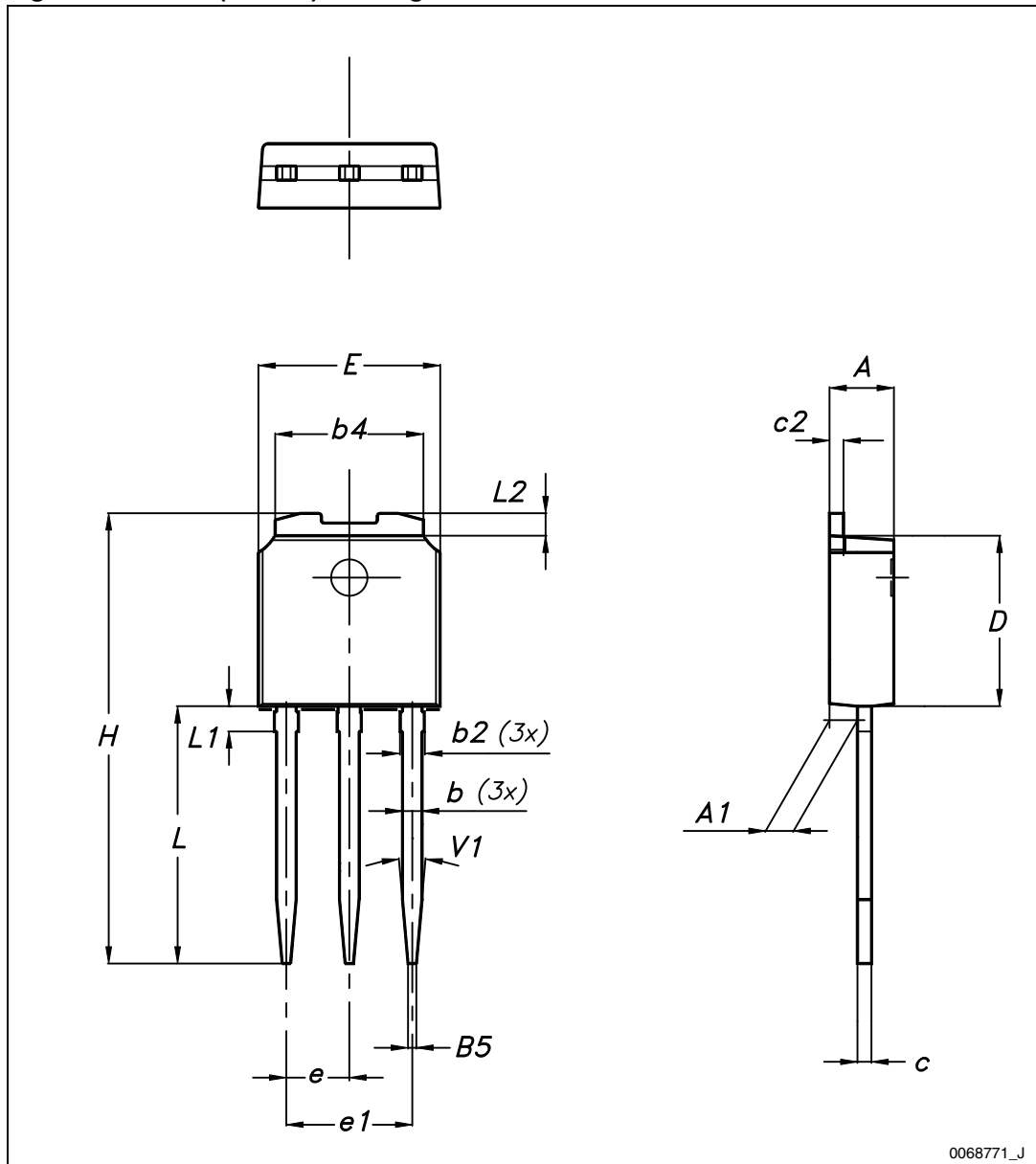

Table 11. IPAK (TO-251) mechanical data

DIM.	mm.		
	min.	typ	max.
A	2.20		2.40
A1	0.90		1.10
b	0.64		0.90
b2			0.95
b4	5.20		5.40
B5		0.3	
c	0.45		0.60
c2	0.48		0.60
D	6.00		6.20
E	6.40		6.60
e		2.28	
e1	4.40		4.60
H		16.10	
L	9.00		9.40
L1	0.80		1.20
L2		0.80	1.00
V1		10 °	

Figure 25. IPAK (TO-251) drawing



## 5 Revision history

Table 12. Document revision history

Date	Revision	Changes
05-Apr-2011	1	First release
07-Nov-2012	2	Added new part numbers: STF16N65K3 in I <sup>2</sup> PAKFP package and STU6N65K3 in IPAK packages. <a href="#">Section 2.1: Electrical characteristics (curves)</a> has been updated. Minor text changes.

**Please Read Carefully:**

Information in this document is provided solely in connection with ST products. STMicroelectronics NV and its subsidiaries ("ST") reserve the right to make changes, corrections, modifications or improvements, to this document, and the products and services described herein at any time, without notice.

All ST products are sold pursuant to ST's terms and conditions of sale.

Purchasers are solely responsible for the choice, selection and use of the ST products and services described herein, and ST assumes no liability whatsoever relating to the choice, selection or use of the ST products and services described herein.

No license, express or implied, by estoppel or otherwise, to any intellectual property rights is granted under this document. If any part of this document refers to any third party products or services it shall not be deemed a license grant by ST for the use of such third party products or services, or any intellectual property contained therein or considered as a warranty covering the use in any manner whatsoever of such third party products or services or any intellectual property contained therein.

**UNLESS OTHERWISE SET FORTH IN ST'S TERMS AND CONDITIONS OF SALE ST DISCLAIMS ANY EXPRESS OR IMPLIED WARRANTY WITH RESPECT TO THE USE AND/OR SALE OF ST PRODUCTS INCLUDING WITHOUT LIMITATION IMPLIED WARRANTIES OF MERCHANTABILITY, FITNESS FOR A PARTICULAR PURPOSE (AND THEIR EQUIVALENTS UNDER THE LAWS OF ANY JURISDICTION), OR INFRINGEMENT OF ANY PATENT, COPYRIGHT OR OTHER INTELLECTUAL PROPERTY RIGHT.**

**UNLESS EXPRESSLY APPROVED IN WRITING BY TWO AUTHORIZED ST REPRESENTATIVES, ST PRODUCTS ARE NOT RECOMMENDED, AUTHORIZED OR WARRANTED FOR USE IN MILITARY, AIR CRAFT, SPACE, LIFE SAVING, OR LIFE SUSTAINING APPLICATIONS, NOR IN PRODUCTS OR SYSTEMS WHERE FAILURE OR MALFUNCTION MAY RESULT IN PERSONAL INJURY, DEATH, OR SEVERE PROPERTY OR ENVIRONMENTAL DAMAGE. ST PRODUCTS WHICH ARE NOT SPECIFIED AS "AUTOMOTIVE GRADE" MAY ONLY BE USED IN AUTOMOTIVE APPLICATIONS AT USER'S OWN RISK.**

Resale of ST products with provisions different from the statements and/or technical features set forth in this document shall immediately void any warranty granted by ST for the ST product or service described herein and shall not create or extend in any manner whatsoever, any liability of ST.

ST and the ST logo are trademarks or registered trademarks of ST in various countries.

Information in this document supersedes and replaces all information previously supplied.

The ST logo is a registered trademark of STMicroelectronics. All other names are the property of their respective owners.

© 2012 STMicroelectronics - All rights reserved



STMicroelectronics group of companies

Australia - Belgium - Brazil - Canada - China - Czech Republic - Finland - France - Germany - Hong Kong - India - Israel - Italy - Japan - Malaysia - Malta - Morocco - Philippines - Singapore - Spain - Sweden - Switzerland - United Kingdom - United States of America

[www.st.com](http://www.st.com)

## Looking for pricing, stock, or lifecycle information?

Click below to explore more details on WIN SOURCE:

-  [View STF6N65K3 on WIN SOURCE](#)
-  [STMicroelectronics Information](#)

## Optimize Your Supply Chain with WIN SOURCE Solutions

-  Global Sourcing Solution
-  Obsolete Management
-  Cost Control Management
-  Shortage Management
-  Alternative Solution
-  Excess Inventory Management