



# THE DATASHEET OF STP12PF06





# STP12PF06 STF12PF06

## P-CHANNEL 60V - 0.18 $\Omega$ - 12A TO-220/TO-220FP STripFET™ II POWER MOSFET

**Table 1: General Features**

TYPE	V <sub>DSS</sub>	R <sub>DS(on)</sub>	I <sub>D</sub>
STP12PF06	60 V	< 0.20 $\Omega$	12 A
STF12PF06	60 V	< 0.20 $\Omega$	12 A

- TYPICAL R<sub>DS(on)</sub> = 0.18  $\Omega$
- EXCEPTIONAL dv/dt CAPABILITY
- 100% AVALANCHE TESTED
- LOW GATE CHARGE
- APPLICATION ORIENTED CHARACTERIZATION

### DESCRIPTION

This Power MOSFET is the latest development of STMicroelectronics unique "Single Feature Size™" strip-based process. The resulting transistor shows extremely high packing density for low on-resistance, rugged avalanche characteristics and less critical alignment steps therefore a remarkable manufacturing reproducibility

### APPLICATIONS

- MOTOR CONTROL
- DC-DC & DC-AC CONVERTERS

**Figure 1: Package**

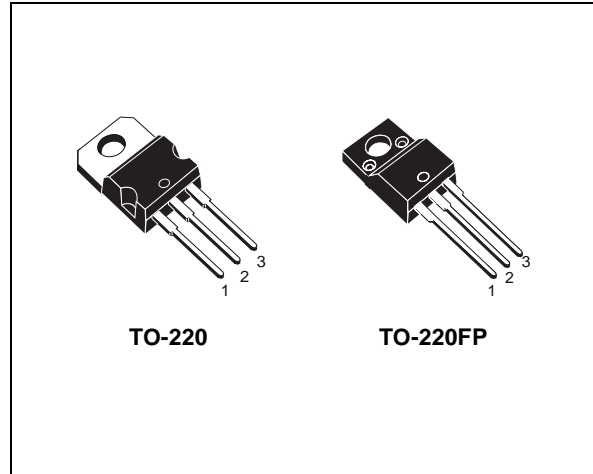

**Figure 2: Internal Schematic Diagram**

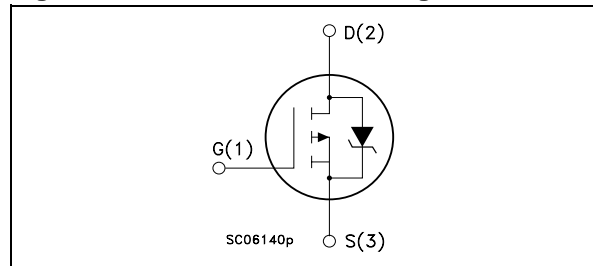

**Table 2: Order Codes**

PART NUMBER	MARKING	PACKAGE	PACKAGING
STP12PF06	P12PF06	TO-220	TUBE
STF12PF06	F12PF06	TO-220FP	TUBE

**Table 3: ABSOLUTE MAXIMUM RATINGS**

Symbol	Parameter	Value		Unit
		STP20PF06	STF20PF06	
V <sub>DS</sub>	Drain-source Voltage (V <sub>GS</sub> = 0)	60		V
V <sub>DGR</sub>	Drain-gate Voltage (R <sub>GS</sub> = 20 k $\Omega$ )	60		V
V <sub>GS</sub>	Gate- source Voltage	$\pm 20$		V
I <sub>D</sub>	Drain Current (continuous) at T <sub>C</sub> = 25°C	12	8	A
I <sub>D</sub>	Drain Current (continuous) at T <sub>C</sub> = 100°C	8.4	5.6	A
I <sub>DM</sub> (●)	Drain Current (pulsed)	48	32	A
P <sub>tot</sub>	Total Dissipation at T <sub>C</sub> = 25°C	60	225	W
	Derating Factor	0.4	0.17	W/°C
dv/dt (1)	Peak Diode Recovery voltage slope	6		V/ns
E <sub>AS</sub> (2)	Single Pulse Avalanche Energy	200		mJ
T <sub>stg</sub>	Storage Temperature	-55 to 175		°C
T <sub>j</sub>	Operating Junction Temperature			

(●) Pulse width limited by safe operating area.

NOTE: For the P-CHANNEL MOSFET actual polarity of voltages and current has to be reversed.

(1) I<sub>SD</sub>  $\leq$  12A, di/dt  $\leq$  200A/ $\mu$ s, V<sub>DD</sub>  $\leq$  V<sub>(BR)DSS</sub>, T<sub>j</sub>  $\leq$  T<sub>JMAX</sub>

(2) Starting T<sub>j</sub> = 25 °C, I<sub>D</sub> = 12A, V<sub>DD</sub> = 25V

## STP12PF06 STF12PF06

**Table 4: THERMAL DATA**

			TO-220	TO-220FP	
Rthj-case	Thermal Resistance Junction-case	Max	2.5	5.35	°C/W
Rthj-amb T <sub>I</sub>	Thermal Resistance Junction-ambient Maximum Lead Temperature For Soldering Purpose	Max	62.5 300		°C/W °C

### ELECTRICAL CHARACTERISTICS (T<sub>CASE</sub> = 25 °C UNLESS OTHERWISE SPECIFIED)

**Table 5: OFF**

Symbol	Parameter	Test Conditions	Min.	Typ.	Max.	Unit
V <sub>(BR)DSS</sub>	Drain-source Breakdown Voltage	I <sub>D</sub> = 250 μA, V <sub>GS</sub> = 0	60			V
I <sub>DSS</sub>	Zero Gate Voltage Drain Current (V <sub>GS</sub> = 0)	V <sub>DS</sub> = Max Rating V <sub>DS</sub> = Max Rating T <sub>C</sub> = 125°C			1 10	μA μA
I <sub>GSS</sub>	Gate-body Leakage Current (V <sub>DS</sub> = 0)	V <sub>GS</sub> = ± 20V			±100	nA

**Table 6: ON (\*)**

Symbol	Parameter	Test Conditions	Min.	Typ.	Max.	Unit
V <sub>GS(th)</sub>	Gate Threshold Voltage	V <sub>DS</sub> = V <sub>GS</sub> I <sub>D</sub> = 250 μA	2	3.4	4	V
R <sub>DS(on)</sub>	Static Drain-source On Resistance	V <sub>GS</sub> = 10 V I <sub>D</sub> = 10 A		0.18	0.20	Ω

**Table 7: DYNAMIC**

Symbol	Parameter	Test Conditions	Min.	Typ.	Max.	Unit
g <sub>fs</sub> (2)	Forward Transconductance	V <sub>DS</sub> = 15 V I <sub>D</sub> = 6 A	2.5	6		S
C <sub>iss</sub> C <sub>oss</sub> C <sub>rss</sub>	Input Capacitance Output Capacitance Reverse Transfer Capacitance	V <sub>DS</sub> = 25V f = 1 MHz V <sub>GS</sub> = 0		850 230 75		pF pF pF

# STP12PF06 STF12PF06

## ELECTRICAL CHARACTERISTICS (continued)

**Table 8: SWITCHING ON**

Symbol	Parameter	Test Conditions	Min.	Typ.	Max.	Unit
$t_{d(on)}$ $t_r$	Turn-on Delay Time Rise Time	$V_{DD} = 30\text{ V}$ $I_D = 6\text{ A}$ $R_G = 4.7\ \Omega$ $V_{GS} = 10\text{ V}$ (Resistive Load, Figure 19)		20 40		ns ns
$Q_g$ $Q_{gs}$ $Q_{gd}$	Total Gate Charge Gate-Source Charge Gate-Drain Charge	$V_{DD} = 48\text{ V}$ $I_D = 12\text{ A}$ $V_{GS} = 10\text{ V}$		16 4 6	21	nC nC nC

**Table 9: SWITCHING OFF**

Symbol	Parameter	Test Conditions	Min.	Typ.	Max.	Unit
$t_{d(off)}$ $t_f$	Turn-off Delay Time Fall Time	$V_{DD} = 30\text{ V}$ $I_D = 6\text{ A}$ $R_G = 4.7\ \Omega$ , $V_{GS} = 10\text{ V}$ (Resistive Load, Figure 19)		40 10		ns ns

**Table 10: SOURCE DRAIN DIODE**

Symbol	Parameter	Test Conditions	Min.	Typ.	Max.	Unit
$I_{SD}$ $I_{SDM}^{(1)}$	Source-drain Current Source-drain Current (pulsed)				10 40	A A
$V_{SD}^{(2)}$	Forward On Voltage	$I_{SD} = 12\text{ A}$ $V_{GS} = 0$			2.5	V
$t_{rr}$ $Q_{rr}$ $I_{RRM}$	Reverse Recovery Time Reverse Recovery Charge Reverse Recovery Current	$I_{SD} = 12\text{ A}$ $di/dt = 100\text{ A}/\mu\text{s}$ $V_{DD} = 30\text{ V}$ $T_j = 150^\circ\text{C}$ (see test circuit, Figure 21)		100 260 5.2		ns nC A

(1) Pulse width limited by safe operating area.  
(2) Pulsed: Pulse duration = 300  $\mu\text{s}$ , duty cycle 1.5 %.

**Figure 3: Safe Operating Area for TO-220**

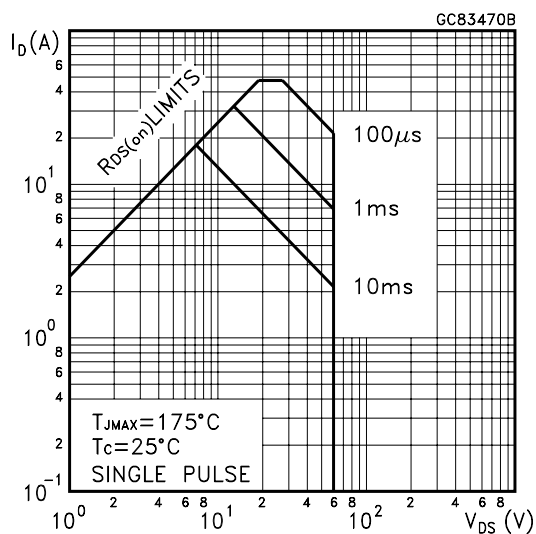

**Figure 4: Safe Operating Area for TO-220FP**

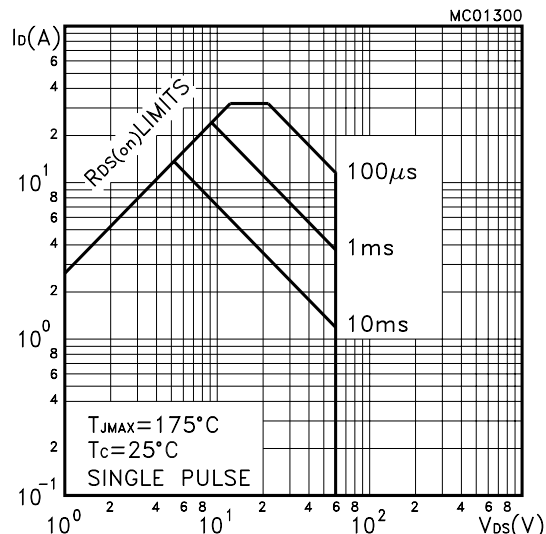

Figure 5: Thermal Impedance

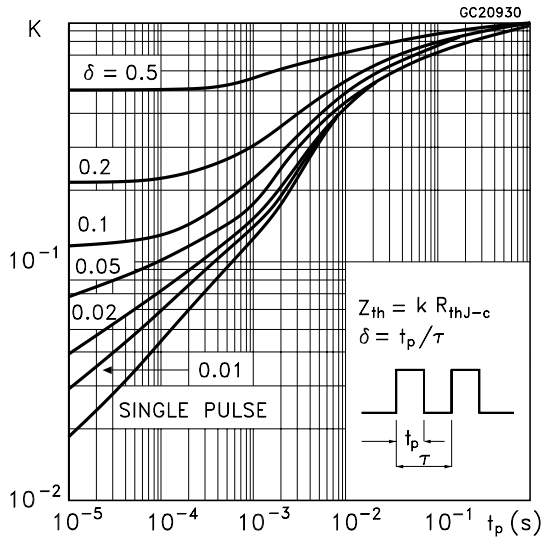

Figure 6: Thermal Impedance for TO-220FP

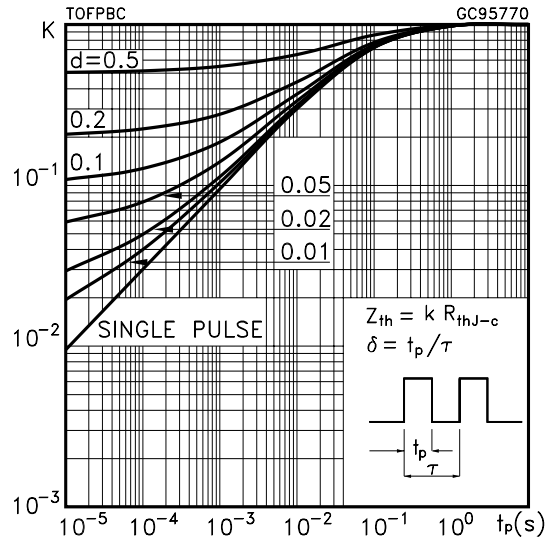

Figure 7: Output Characteristics

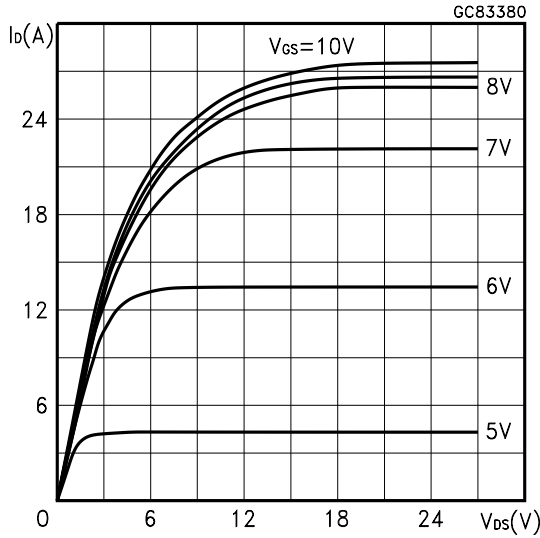

Figure 8: Transfer Characteristics

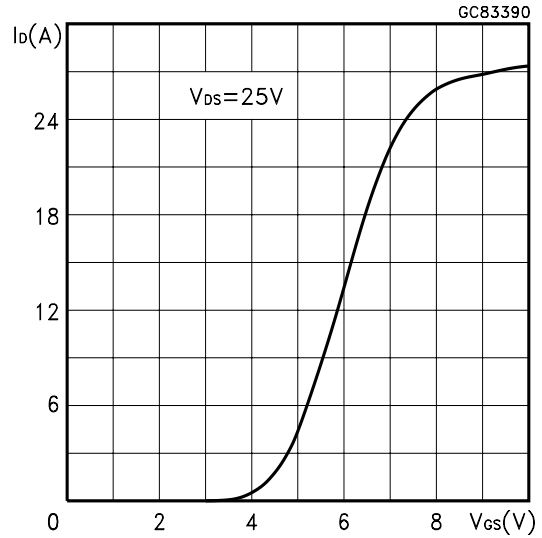

Figure 9: Transconductance

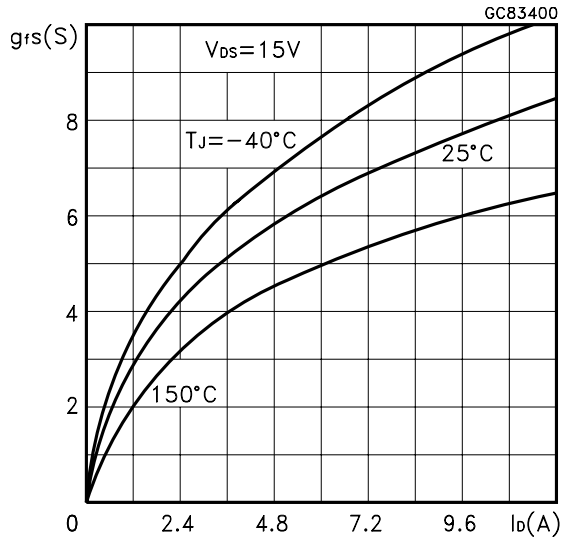

Figure 10: Static Drain-source On Resistance

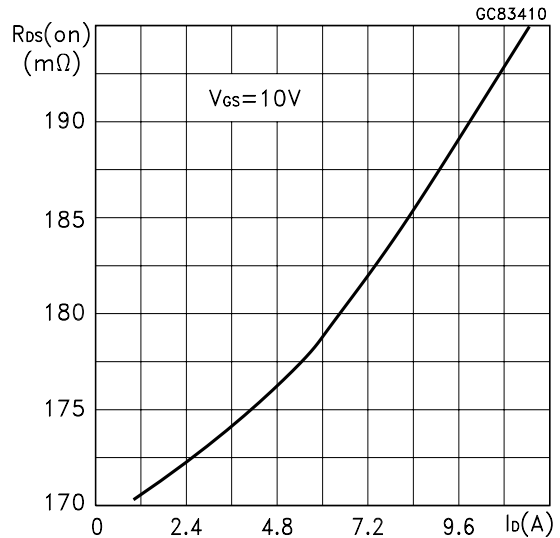

Figure 11: Gate Charge vs Gate-source Voltage

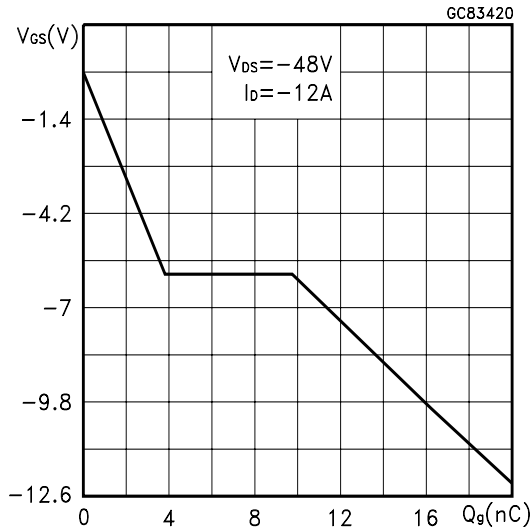

Figure 13: Normalized Gate Threshold Voltage vs Temperature

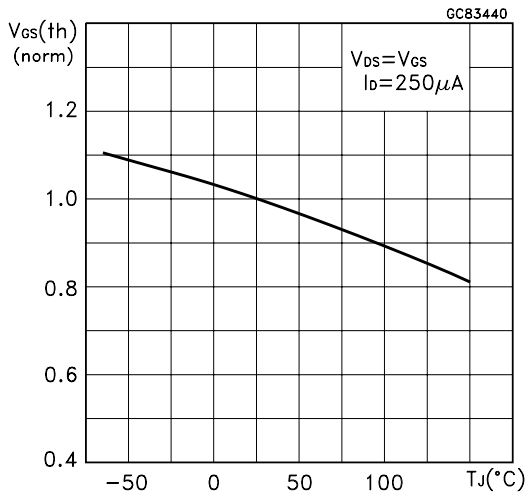

Figure 15: Source-drain Diode Forward Characteristics

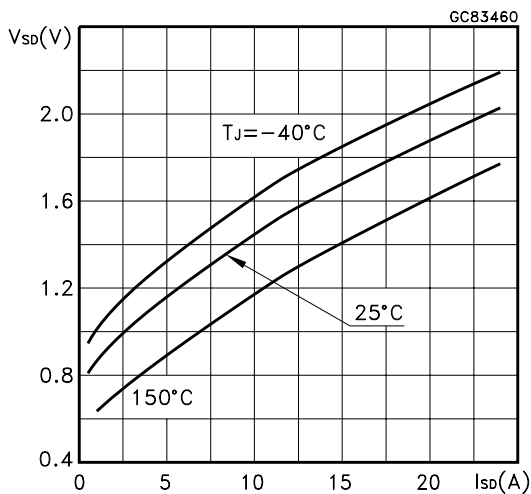

Figure 12: Capacitance Variations

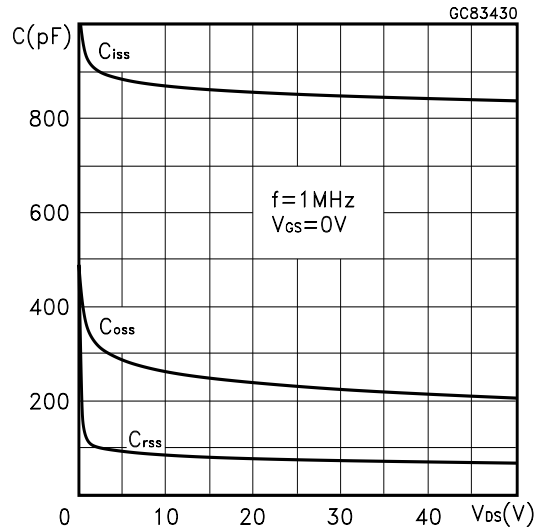

Figure 14: Normalized on Resistance vs Temperature

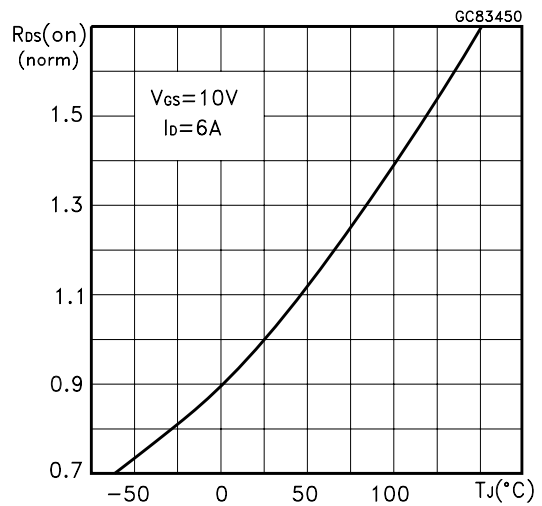

Figure 16: Normalized Breakdown Voltage Temperature

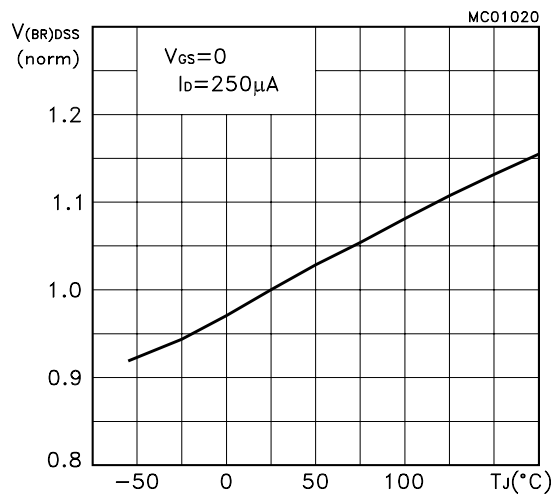

Figure 17: Unclamped Inductive Load Test Circuit

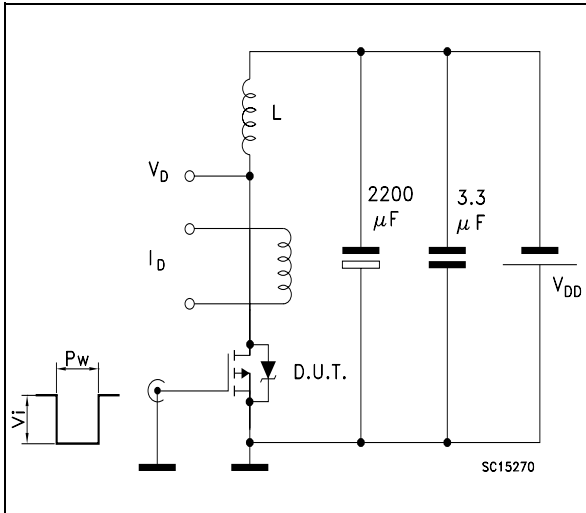

Figure 18: Unclamped Inductive Waveform

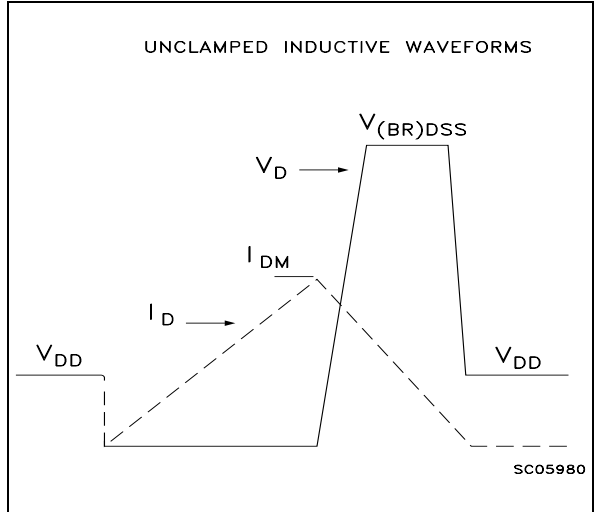

Figure 19: Switching Times Test Circuits For Resistive Load

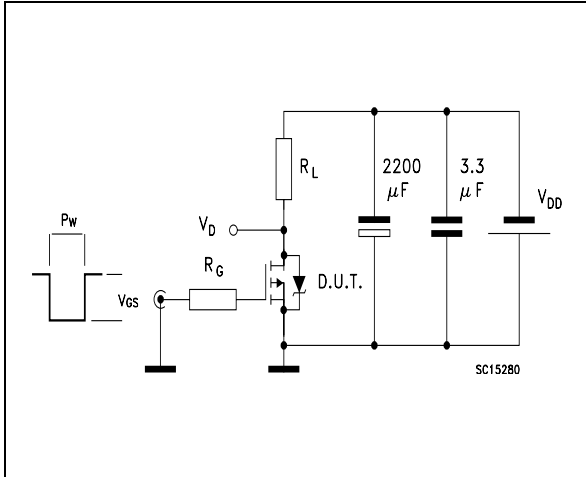

Figure 20: Gate Charge test Circuit

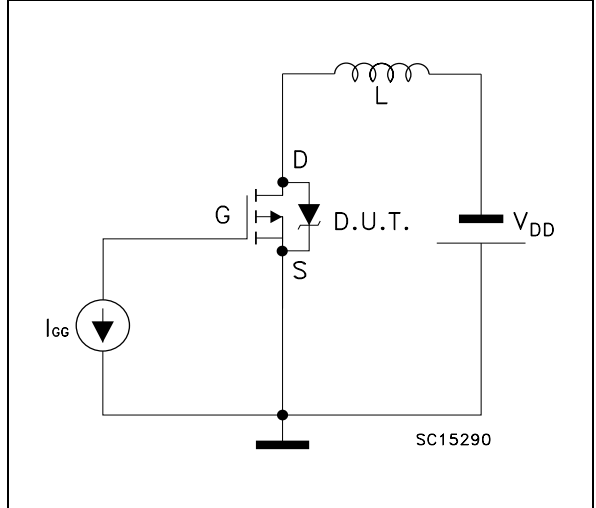
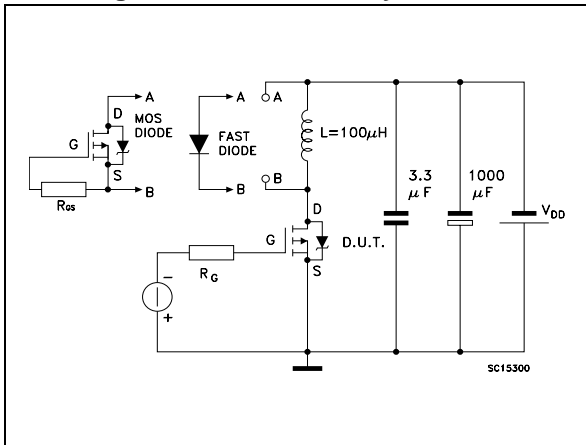
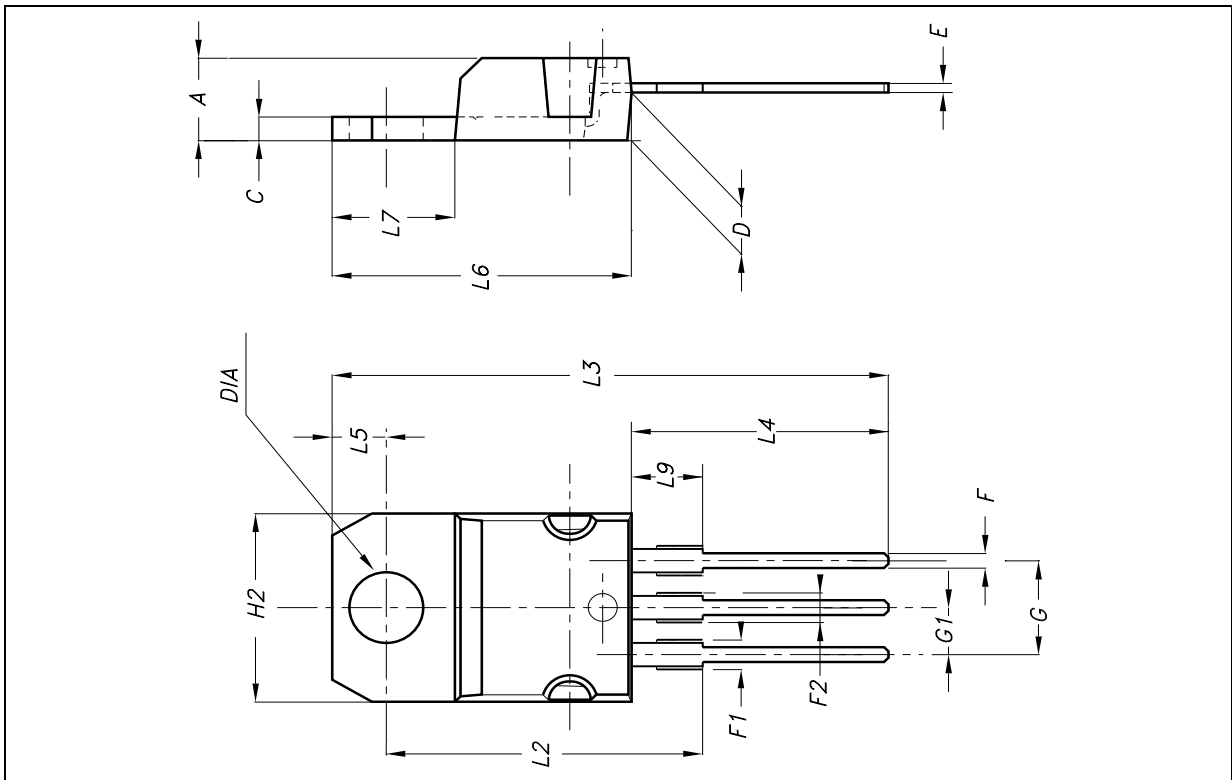

Figure 21: Test Circuit For Inductive Load Switching And Diode Recovery Times



**TO-220 MECHANICAL DATA**

DIM.	mm.			inch.		
	MIN.	TYP.	MAX.	MIN.	TYP.	TYP.
A	4.4		4.6	0.173		0.181
C	1.23		1.32	0.048		0.051
D	2.40		2.72	0.094		0.107
E	0.49		0.70	0.019		0.027
F	0.61		0.88	0.024		0.034
F1	1.14		1.70	0.044		0.067
F2	1.14		1.70	0.044		0.067
G	4.95		5.15	0.194		0.203
G1	2.40		2.70	0.094		0.106
H2	10		10.40	0.393		0.409
L2		16.40			0.645	
L3		28.90			1.137	
L4	13		14	0.511		0.551
L5	2.65		2.95	0.104		0.116
L6	15.25		15.75	0.600		0.620
L7	6.20		6.60	0.244		0.260
L9	3.50		3.93	0.137		0.154
DIA	3.75		3.85	0.147		0.151



**TO-220FP MECHANICAL DATA**

DIM.	mm			inch		
	MIN.	TYP.	MAX.	MIN.	TYP.	MAX.
A	4.4		4.6	0.173		0.181
B	2.5		2.7	0.098		0.106
D	2.5		2.75	0.098		0.108
E	0.45		0.7	0.017		0.027
F	0.75		1	0.030		0.039
F1	1.15		1.7	0.045		0.067
F2	1.15		1.7	0.045		0.067
G	4.95		5.2	0.195		0.204
G1	2.4		2.7	0.094		0.106
H	10		10.4	0.393		0.409
L2		16			0.630	
L3	28.6		30.6	1.126		1.204
L4	9.8		10.6	0.385		0.417
L6	15.9		16.4	0.626		0.645
L7	9		9.3	0.354		0.366
Ø	3		3.2	0.118		0.126

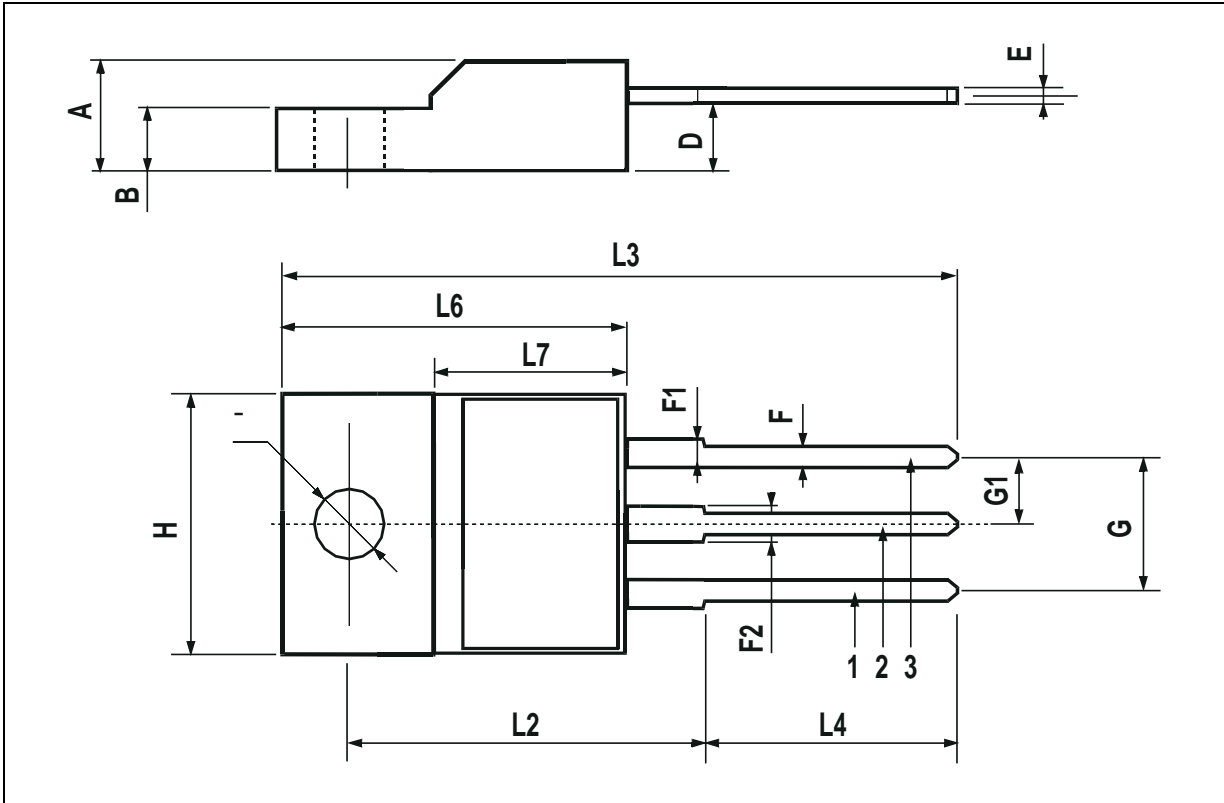

**Table 11:Revision History**

<b>Date</b>	<b>Revision</b>	<b>Description of Changes</b>
March 2005	1.0	FIRST ISSUE
March 2005	2.0	MINOR REVISION

Information furnished is believed to be accurate and reliable. However, STMicroelectronics assumes no responsibility for the consequences of use of such information nor for any infringement of patents or other rights of third parties which may result from its use. No license is granted by implication or otherwise under any patent or patent rights of STMicroelectronics. Specifications mentioned in this publication are subject to change without notice. This publication supersedes and replaces all information previously supplied. STMicroelectronics products are not authorized for use as critical components in life support devices or systems without express written approval of STMicroelectronics.

The ST logo is registered trademark of STMicroelectronics  
All other names are the property of their respective owners.

© 2005 STMicroelectronics - All Rights Reserved

STMicroelectronics group of companies  
Australia - Belgium - Brazil - Canada - China - Czech Republic - Finland - France - Germany - Hong Kong - India - Israel - Italy - Japan -  
Malaysia - Malta - Morocco -Singapore - Spain - Sweden - Switzerland - United Kingdom - United States of America.  
**www.st.com**

## Looking for pricing, stock, or lifecycle information?

Click below to explore more details on WIN SOURCE:

- ⊖ [View STP12PF06 on WIN SOURCE](#)
- ⊖ [STMicroelectronics Information](#)

## Optimize Your Supply Chain with WIN SOURCE Solutions

- ✓ Global Sourcing Solution
- ✓ Obsolete Management
- ✓ Cost Control Management
- ✓ Shortage Management
- ✓ Alternative Solution
- ✓ Excess Inventory Management