



# THE DATASHEET OF STP26NM60N



N-channel 600 V, 0.135  $\Omega$  typ., 20 A MDmesh™ II  
Power MOSFETs in D<sup>2</sup>PAK and TO-220 packages

Datasheet - production data

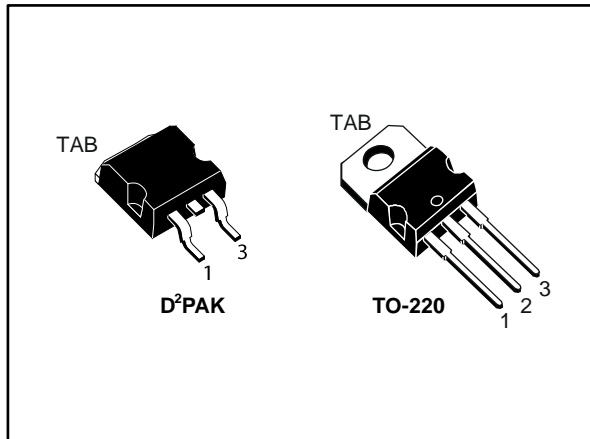
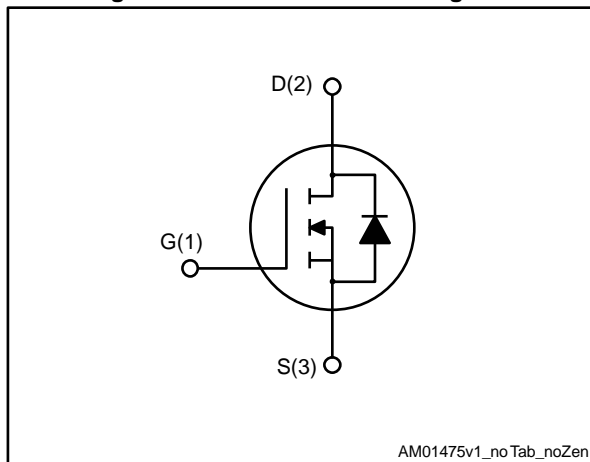

Figure 1: Internal schematic diagram



## Features

Order code	V <sub>DS</sub>	R <sub>DS(on)</sub> max	I <sub>D</sub>
STB26NM60N	600 V	0.165 $\Omega$	20 A
STP26NM60N			

- 100% avalanche tested
- Low input capacitance and gate charge
- Low gate input resistance

## Applications

- Switching applications

## Description

These devices are N-channel Power MOSFETs developed using the second generation of MDmesh™ technology. This revolutionary Power MOSFET associates a vertical structure to the company's strip layout to yield one of the world's lowest on-resistance and gate charge. It is therefore suitable for the most demanding high efficiency converters.

Table 1: Device summary

Order code	Marking	Package	Packaging
STB26NM60N	26NM60N	D <sup>2</sup> PAK	Tape and reel
STP26NM60N		TO-220	Tube

---

# Contents

- 1 Electrical ratings ..... 3**
- 2 Electrical characteristics ..... 4**
  - 2.1 Electrical characteristics (curves)..... 6
- 3 Test circuits ..... 8**
- 4 Package information ..... 9**
  - 4.1 D2PAK (TO-263) type A package information..... 9
  - 4.2 D2PAK packaging information ..... 12
  - 4.3 TO-220 type A package information..... 14
- 5 Revision history ..... 16**



# 1 Electrical ratings

**Table 2: Absolute maximum ratings**

Symbol	Parameter	Value	Unit
$V_{DS}$	Drain-source voltage	600	V
$V_{GS}$	Gate-source voltage	$\pm 30$	V
$I_D$	Drain current (continuous) at $T_C = 25\text{ }^\circ\text{C}$	20	A
$I_D$	Drain current (continuous) at $T_C = 100\text{ }^\circ\text{C}$	12.6	A
$I_{DM}^{(1)}$	Drain current (pulsed)	80	A
$P_{TOT}$	Total dissipation at $T_C = 25\text{ }^\circ\text{C}$	140	W
$dv/dt^{(2)}$	Peak diode recovery voltage slope	15	V/ns
$T_{stg}$	Storage temperature range	-55 to 150	$^\circ\text{C}$
$T_j$	Operating junction temperature range		

**Notes:**

(1) Pulse width limited by safe operating area.

(2)  $I_{SD} \leq 20\text{ A}$ ,  $di/dt \leq 400\text{ A}/\mu\text{s}$ ,  $V_{DS(\text{peak})} \leq V_{(BR)DSS}$ ,  $V_{DD} = 80\% V_{(BR)DSS}$

**Table 3: Thermal data**

Symbol	Parameter	Value		Unit
		D <sup>2</sup> PAK	TO-220	
$R_{thj\text{-case}}$	Thermal resistance junction-case	0.89		$^\circ\text{C}/\text{W}$
$R_{thj\text{-amb}}$	Thermal resistance junction-ambient		62.5	$^\circ\text{C}/\text{W}$
$R_{thj\text{-pcb}}^{(1)}$	Thermal resistance junction-pcb	30		$^\circ\text{C}/\text{W}$

**Notes:**

(1) When mounted on FR-4 board of 1inch<sup>2</sup>, 2oz Cu,  $t < 10\text{ s}$ .

**Table 4: Avalanche characteristics**

Symbol	Parameter	Value	Unit
$I_{AS}$	Single pulse avalanche current (pulse width limited by $T_{j\text{max}}$ )	6	A
$E_{AS}$	Single pulse avalanche energy (starting $T_J=25\text{ }^\circ\text{C}$ , $I_D=I_{AS}$ , $V_{DD}=50\text{ V}$ )	610	mJ

## 2 Electrical characteristics

(T<sub>CASE</sub> = 25 °C unless otherwise specified)

**Table 5: On/off states**

Symbol	Parameter	Test conditions	Min.	Typ.	Max.	Unit
V <sub>(BR)DSS</sub>	Drain-source breakdown voltage	I <sub>D</sub> = 1 mA, V <sub>GS</sub> = 0 V	600			V
I <sub>DSS</sub>	Zero gate voltage drain current	V <sub>GS</sub> = 0 V, V <sub>DS</sub> = 600 V			1	μA
		V <sub>GS</sub> = 0 V, V <sub>DS</sub> = 600 V, T <sub>C</sub> = 125 °C <sup>(1)</sup>			100	
I <sub>GSS</sub>	Gate-body leakage current	V <sub>DS</sub> = 0 V, V <sub>GS</sub> = ±25 V			±0.1	μA
V <sub>GS(th)</sub>	Gate threshold voltage	V <sub>DS</sub> = V <sub>GS</sub> , I <sub>D</sub> = 250 μA	2	3	4	V
R <sub>DS(on)</sub>	Static drain-source on-resistance	V <sub>GS</sub> = 10 V, I <sub>D</sub> = 10 A		0.135	0.165	Ω

**Notes:**

<sup>(1)</sup>Defined by design, not subject to production test.

**Table 6: Dynamic**

Symbol	Parameter	Test conditions	Min.	Typ.	Max.	Unit
C <sub>iss</sub>	Input capacitance	V <sub>DS</sub> = 50 V, f = 1 MHz, V <sub>GS</sub> = 0 V	-	1800	-	pF
C <sub>oss</sub>	Output capacitance		-	115	-	pF
C <sub>rss</sub>	Reverse transfer capacitance		-	6	-	pF
C <sub>oss eq.</sub> <sup>(1)</sup>	Equivalent output capacitance	V <sub>GS</sub> = 0 V, V <sub>DS</sub> = 0 to 480 V	-	310	-	pF
Q <sub>g</sub>	Total gate charge	V <sub>DD</sub> = 480 V, I <sub>D</sub> = 20 A, V <sub>GS</sub> = 10 V (see <a href="#">Figure 14: "Test circuit for gate charge behavior"</a> )	-	60	-	nC
Q <sub>gs</sub>	Gate-source charge		-	8.5	-	nC
Q <sub>gd</sub>	Gate-drain charge		-	30	-	nC
R <sub>G</sub>	Gate input resistance	f=1 MHz, I <sub>D</sub> =0 A	-	2.8	-	Ω

**Notes:**

<sup>(1)</sup>C<sub>oss eq.</sub> is defined as a constant equivalent capacitance giving the same charging time as C<sub>oss</sub> when V<sub>DS</sub> increases from 0 to 80% V<sub>DS</sub>

Table 7: Switching times

Symbol	Parameter	Test conditions	Min.	Typ.	Max.	Unit
$t_{d(on)}$	Turn-on delay time	$V_{DD} = 300\text{ V}$ , $I_D = 10\text{ A}$ , $R_G = 4.7\ \Omega$ , $V_{GS} = 10\text{ V}$ (see <a href="#">Figure 13: "Test circuit for resistive load switching times"</a> and <a href="#">Figure 18: "Switching time waveform"</a> )	-	13	-	ns
$t_r$	Rise time		-	25	-	ns
$t_{d(off)}$	Turn-off delay time		-	85	-	ns
$t_f$	Fall time		-	50	-	ns

Table 8: Source-drain diode

Symbol	Parameter	Test conditions	Min.	Typ.	Max.	Unit
$I_{SD}$	Source-drain current		-		20	A
$I_{SDM}^{(1)}$	Source-drain current (pulsed)		-		80	A
$V_{SD}^{(2)}$	Forward on voltage	$I_{SD} = 20\text{ A}$ , $V_{GS} = 0$	-		1.5	V
$t_{rr}$	Reverse recovery time	$I_{SD} = 20\text{ A}$ , $di/dt = 100\text{ A}/\mu\text{s}$ $V_{DD} = 60\text{ V}$ (see <a href="#">Figure 15: "Test circuit for inductive load switching and diode recovery times"</a> )	-	370		ns
$Q_{rr}$	Reverse recovery charge		-	5.8		$\mu\text{C}$
$I_{RRM}$	Reverse recovery current		-	31.6		A
$t_{rr}$	Reverse recovery time	$I_{SD} = 20\text{ A}$ , $di/dt = 100\text{ A}/\mu\text{s}$ $V_{DD} = 60\text{ V}$ , $T_j = 150\text{ }^\circ\text{C}$ (see <a href="#">Figure 15: "Test circuit for inductive load switching and diode recovery times"</a> )	-	450		ns
$Q_{rr}$	Reverse recovery charge		-	7.5		$\mu\text{C}$
$I_{RRM}$	Reverse recovery current		-	32.5		A

**Notes:**

(1) Pulse width limited by safe operating area.

(2) Pulsed: pulse duration = 300  $\mu\text{s}$ , duty cycle 1.5%

## 2.1 Electrical characteristics (curves)

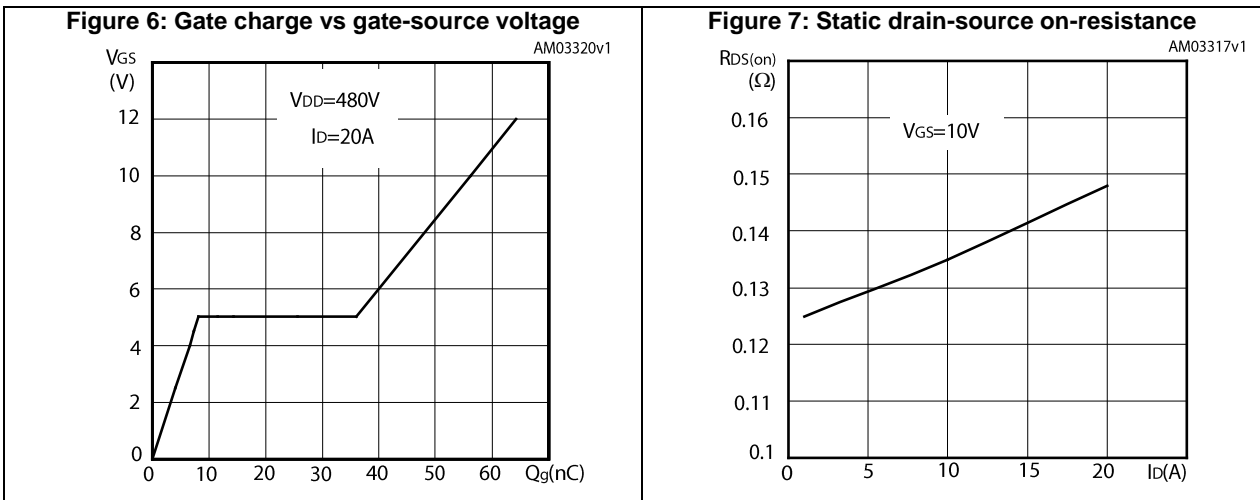
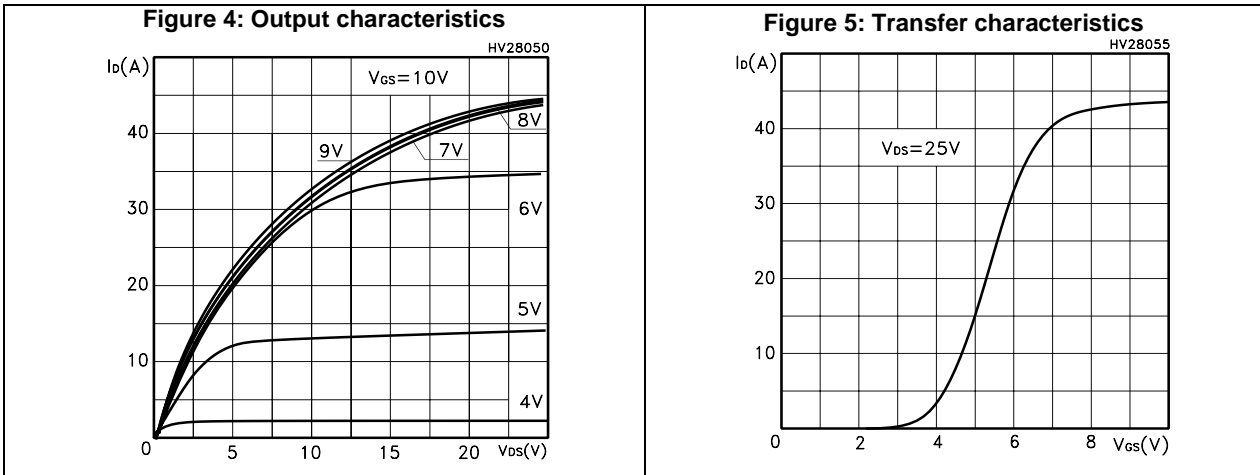
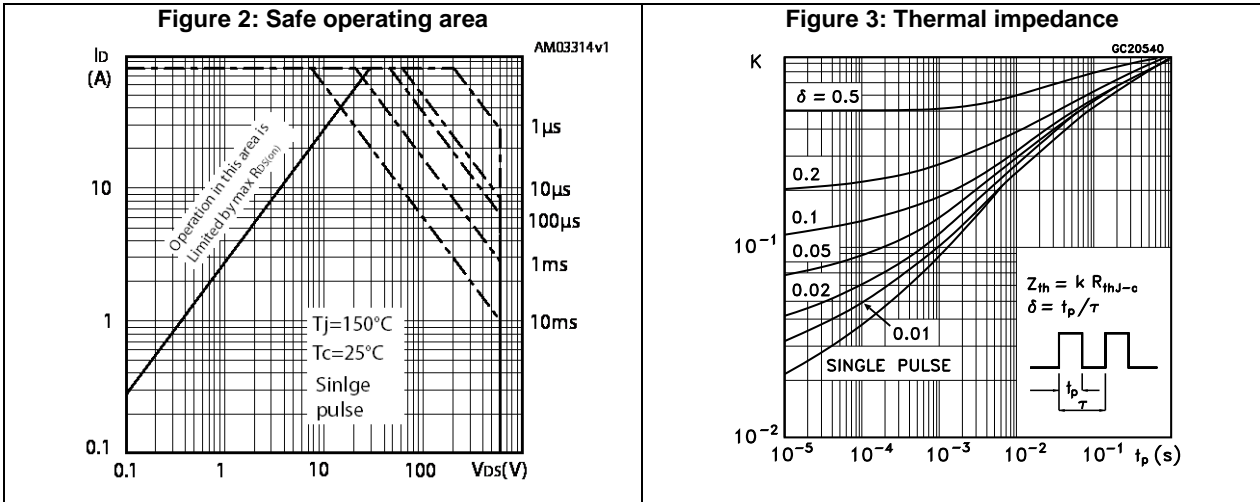

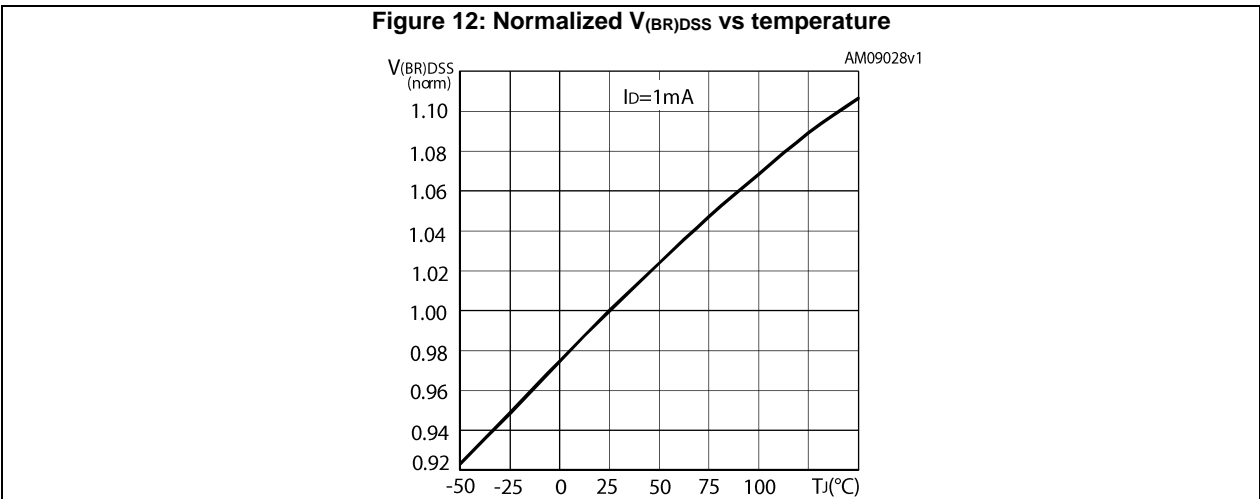
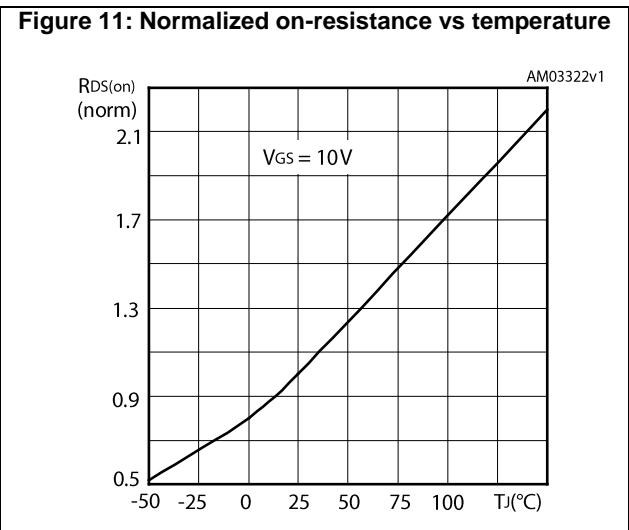
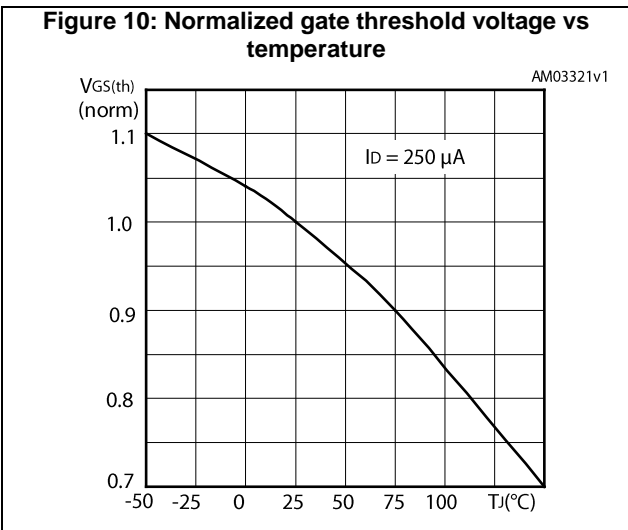
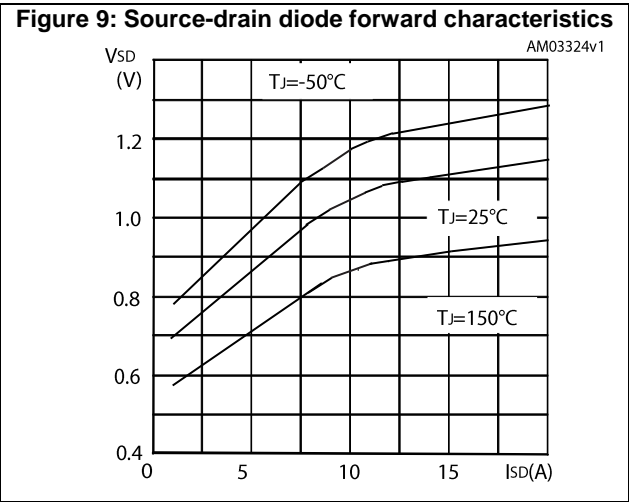
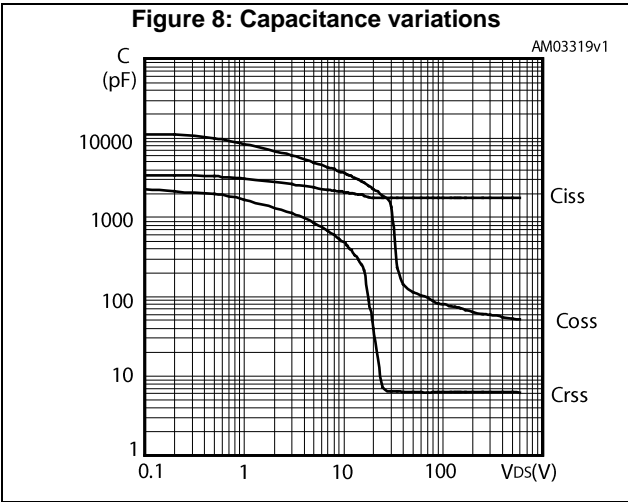

### 3 Test circuits

**Figure 13: Test circuit for resistive load switching times**

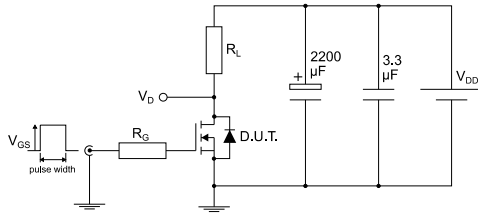

AM01468v1

**Figure 14: Test circuit for gate charge behavior**

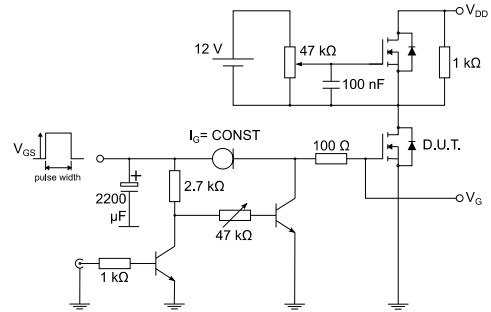

AM01469v1

**Figure 15: Test circuit for inductive load switching and diode recovery times**

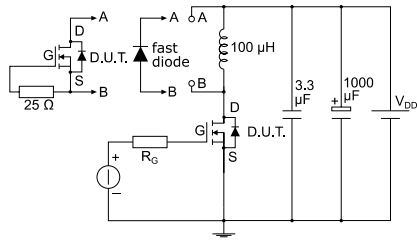

AM01470v1

**Figure 16: Unclamped inductive load test circuit**

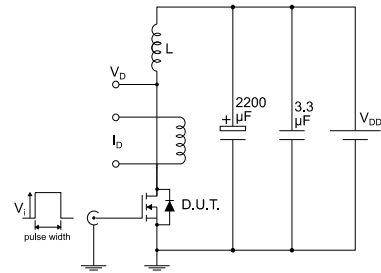

AM01471v1

**Figure 17: Unclamped inductive waveform**

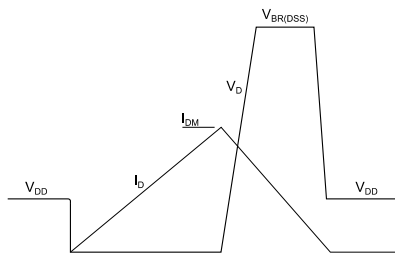

AM01472v1

**Figure 18: Switching time waveform**

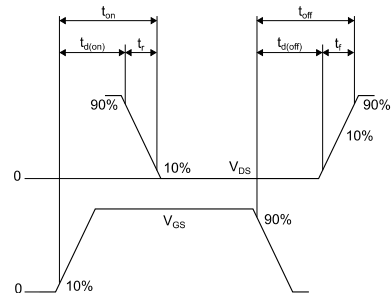

AM01473v1

## 4 Package information

In order to meet environmental requirements, ST offers these devices in different grades of ECOPACK® packages, depending on their level of environmental compliance. ECOPACK® specifications, grade definitions and product status are available at: [www.st.com](http://www.st.com). ECOPACK® is an ST trademark.

### 4.1 D2PAK (TO-263) type A package information

Figure 19: D<sup>2</sup>PAK (TO-263) type A package outline

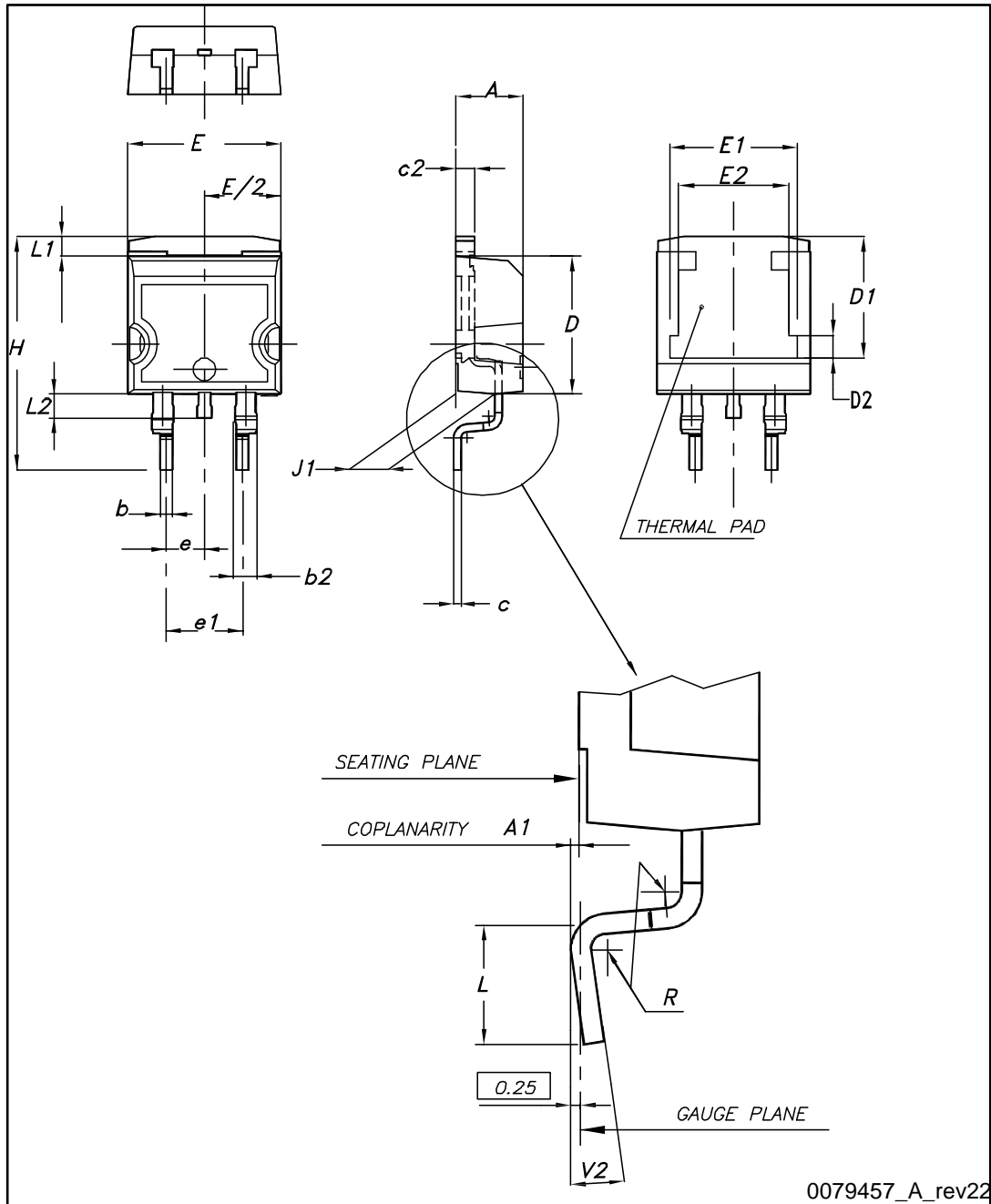
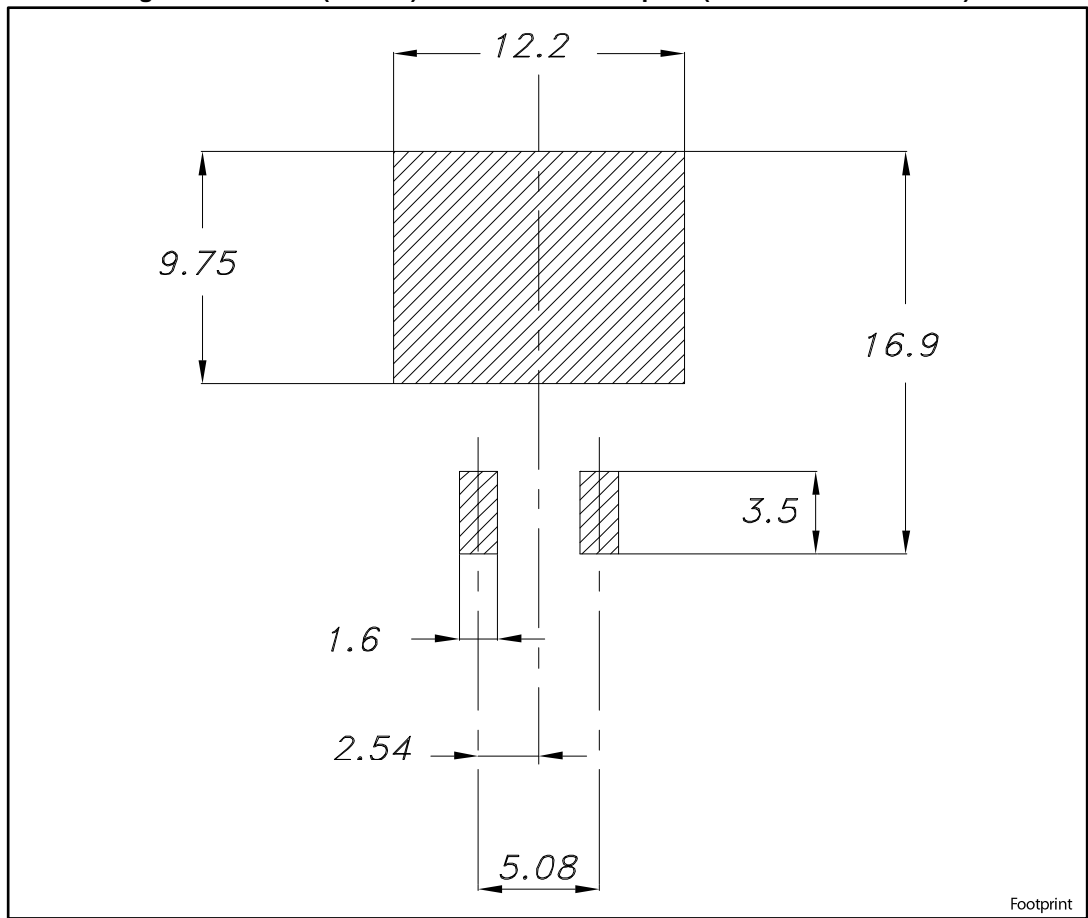

Table 9: D<sup>2</sup>PAK (TO-263) type A package mechanical data

Dim.	mm		
	Min.	Typ.	Max.
A	4.40		4.60
A1	0.03		0.23
b	0.70		0.93
b2	1.14		1.70
c	0.45		0.60
c2	1.23		1.36
D	8.95		9.35
D1	7.50	7.75	8.00
D2	1.10	1.30	1.50
E	10		10.40
E1	8.50	8.70	8.90
E2	6.85	7.05	7.25
e		2.54	
e1	4.88		5.28
H	15		15.85
J1	2.49		2.69
L	2.29		2.79
L1	1.27		1.40
L2	1.30		1.75
R		0.4	
V2	0°		8°

Figure 20: D<sup>2</sup>PAK (TO-263) recommended footprint (dimensions are in mm)



Footprint

### 4.2 D2PAK packaging information

Figure 21: Tape outline

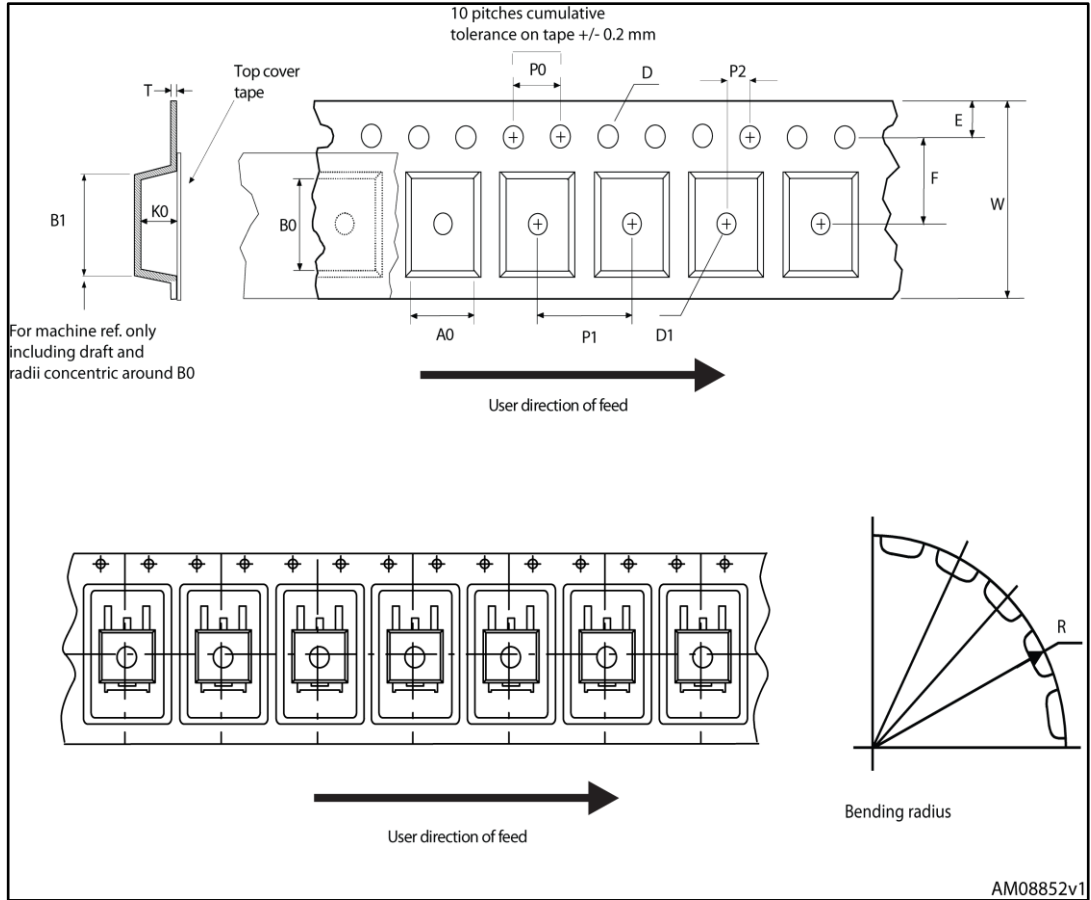
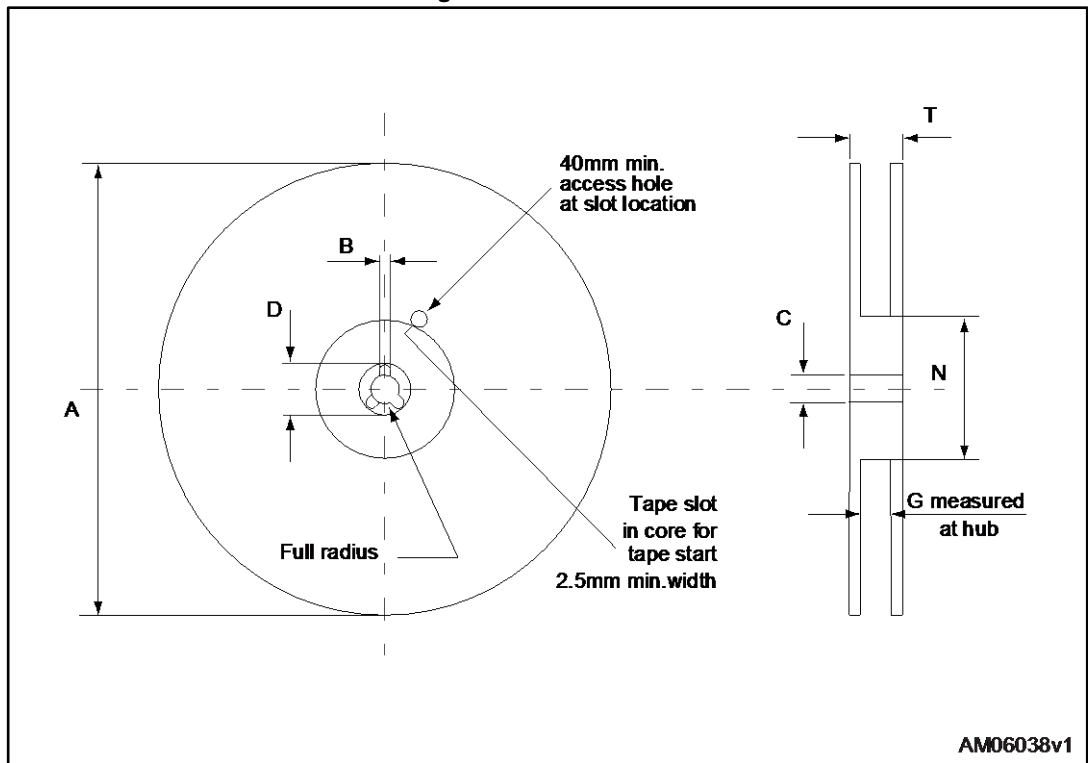

Figure 22: Reel outline



AM06038v1

Table 10: D<sup>2</sup>PAK tape and reel mechanical data

Tape			Reel		
Dim.	mm		Dim.	mm	
	Min.	Max.		Min.	Max.
A0	10.5	10.7	A		330
B0	15.7	15.9	B	1.5	
D	1.5	1.6	C	12.8	13.2
D1	1.59	1.61	D	20.2	
E	1.65	1.85	G	24.4	26.4
F	11.4	11.6	N	100	
K0	4.8	5.0	T		30.4
P0	3.9	4.1			
P1	11.9	12.1	Base quantity		1000
P2	1.9	2.1	Bulk quantity		1000
R	50				
T	0.25	0.35			
W	23.7	24.3			

### 4.3 TO-220 type A package information

Figure 23: TO-220 type A package outline

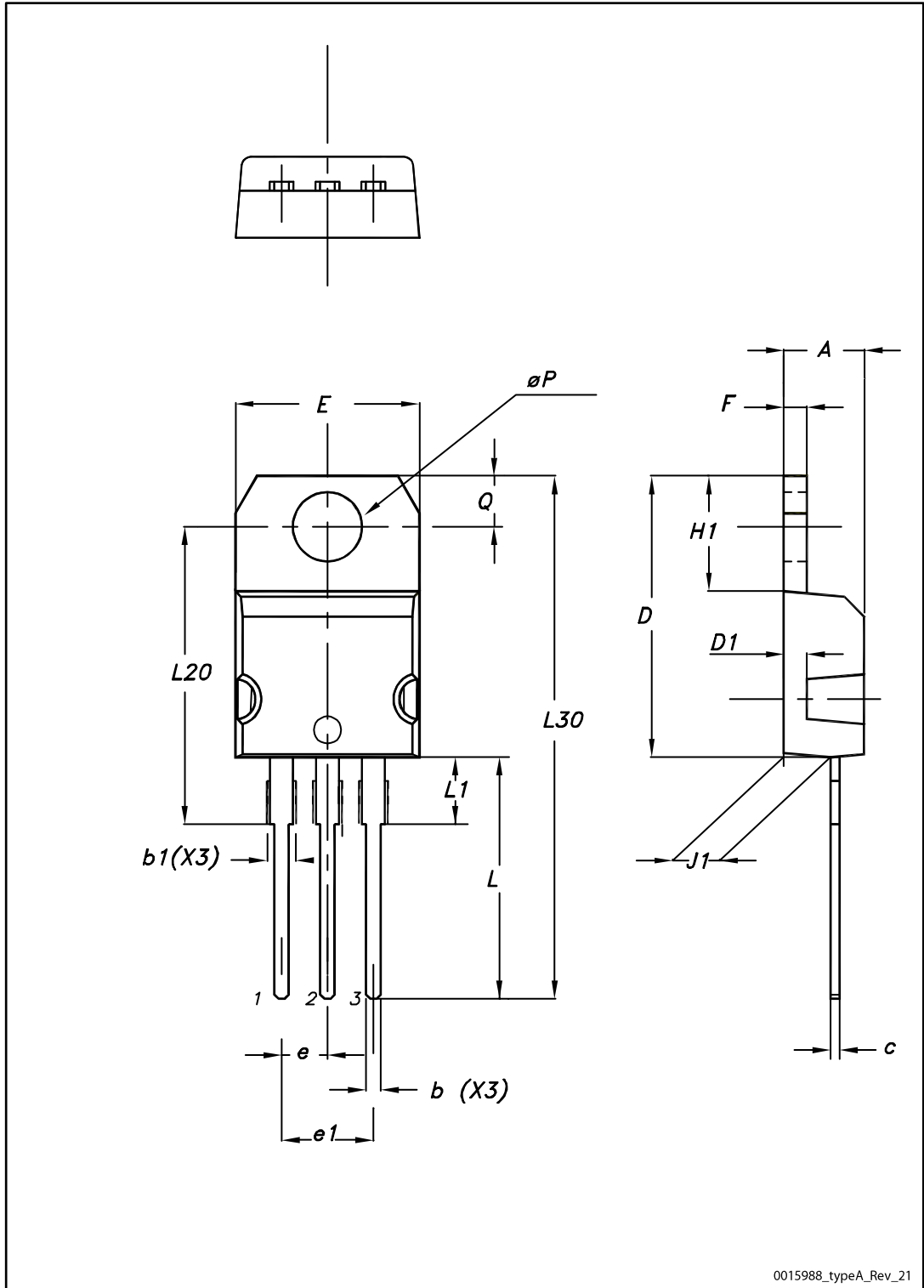

0015988\_typeA\_Rev\_21

Table 11: TO-220 type A mechanical data

Dim.	mm		
	Min.	Typ.	Max.
A	4.40		4.60
b	0.61		0.88
b1	1.14		1.55
c	0.48		0.70
D	15.25		15.75
D1		1.27	
E	10.00		10.40
e	2.40		2.70
e1	4.95		5.15
F	1.23		1.32
H1	6.20		6.60
J1	2.40		2.72
L	13.00		14.00
L1	3.50		3.93
L20		16.40	
L30		28.90	
øP	3.75		3.85
Q	2.65		2.95

## 5 Revision history

Table 12: Document revision history

Date	Revision	Changes
29-Apr-2009	1	First release.
17-Dec-2009	2	Added new package, mechanical data: D <sup>2</sup> PAK
20-Jun-2011	3	Inserted device in I <sup>2</sup> PAK.
13-Mar-2012	4	Updated P <sub>TOT</sub> and derating factor in <i>Table 2</i> . Update R <sub>thj-case</sub> for TO-220FP in <i>Table 3</i> . Update <i>Figure 10</i> and <i>Figure 15</i> . Update <i>Section 5: Packaging mechanical data</i> .
20-Jun-2012	5	Updated title on the cover page. Minor text changes.
09-Sep-2013	6	– The part numbers STI26NM60N and STW26NM60N have been moved to the separate datasheets – Modified: V <sub>GS</sub> value in <i>Table 2</i> .
12-Dec-2016	7	The part number STF26NM60N has been moved to a separate datasheet. Modified <i>Table 2: "Absolute maximum ratings"</i> , <i>Table 3: "Thermal data"</i> , <i>Table 5: "On/off states"</i> , <i>Table 6: "Dynamic"</i> and <i>Table 7: "Switching times"</i> . Modified <i>Section 2.1: "Electrical characteristics (curves)"</i> . Minor text changes.

**IMPORTANT NOTICE – PLEASE READ CAREFULLY**

STMicroelectronics NV and its subsidiaries ("ST") reserve the right to make changes, corrections, enhancements, modifications, and improvements to ST products and/or to this document at any time without notice. Purchasers should obtain the latest relevant information on ST products before placing orders. ST products are sold pursuant to ST's terms and conditions of sale in place at the time of order acknowledgement.

Purchasers are solely responsible for the choice, selection, and use of ST products and ST assumes no liability for application assistance or the design of Purchasers' products.

No license, express or implied, to any intellectual property right is granted by ST herein.

Resale of ST products with provisions different from the information set forth herein shall void any warranty granted by ST for such product.

ST and the ST logo are trademarks of ST. All other product or service names are the property of their respective owners.

Information in this document supersedes and replaces information previously supplied in any prior versions of this document.

© 2016 STMicroelectronics – All rights reserved

## Looking for pricing, stock, or lifecycle information?

Click below to explore more details on WIN SOURCE:

-  [View STP26NM60N on WIN SOURCE](#)
-  [STMicroelectronics Information](#)

## Optimize Your Supply Chain with WIN SOURCE Solutions

-  Global Sourcing Solution
-  Obsolete Management
-  Cost Control Management
-  Shortage Management
-  Alternative Solution
-  Excess Inventory Management