



THE DATASHEET OF STP8NK80ZFP





STP8NK80Z - STP8NK80ZFP STW8NK80Z

N-channel 800V - 1.3Ω - 6.2A - TO-220 /TO-220FP/TO-247
Zener-protected SuperMESH™ Power MOSFET

Features

| Type | V _{DSS} | R _{DS(on)} | I _D |
|-------------|------------------|---------------------|----------------|
| STP8NK80Z | 800 V | < 1.5 Ω | 6.2 A |
| STP8NK80ZFP | 800 V | < 1.5 Ω | 6.2 A |
| STW8NK80Z | 800 V | < 1.5 Ω | 6.2 A |

- Extremely high dv/dt capability
- 100% avalanche tested
- Gate charge minimized
- Very low intrinsic capacitances
- Very good manufacturing repeatability

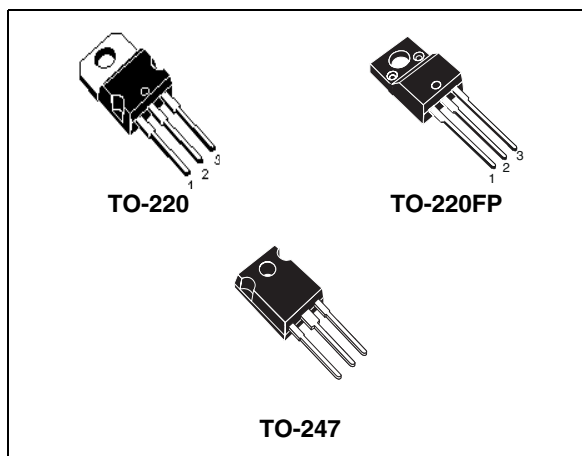

Description

The SuperMESH™ series is obtained through an extreme optimization of ST's well established strip-based PowerMESH™ layout. In addition to pushing on-resistance significantly down, special care is taken to ensure a very good dv/dt capability for the most demanding applications. Such series complements ST full range of high voltage MOSFETs including revolutionary MDmesh™ products.

Application

- Switching applications

Figure 1. Internal schematic diagram

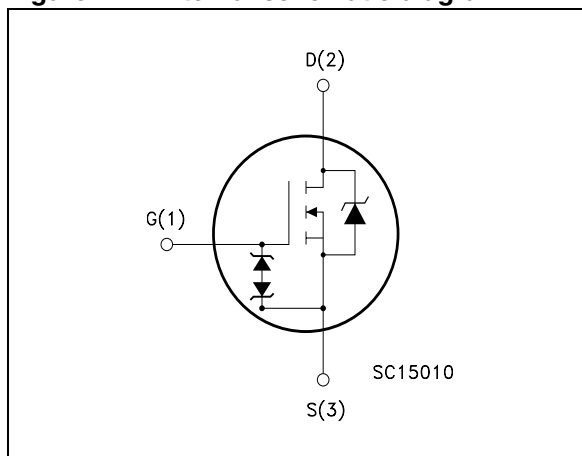

Table 1. Device summary

| Order codes | Marking | Package | Packaging |
|-------------|-----------|----------|-----------|
| STP8NK80Z | P8NK80Z | TO-220 | Tube |
| STP8NK80ZFP | P8NK80ZFP | TO-220FP | Tube |
| STW8NK80Z | W8NK80Z | TO-247 | Tube |

Contents

| | | |
|----------|---|-----------|
| 1 | Electrical ratings | 3 |
| 2 | Electrical characteristics | 4 |
| | 2.1 Electrical characteristics (curves) | 6 |
| 3 | Test circuit | 9 |
| 4 | Package mechanical data | 10 |
| 5 | Revision history | 14 |

1 Electrical ratings

Table 2. Absolute maximum ratings

| Symbol | Parameter | Value | | Unit |
|--------------------|---|-----------------|---------------------|---------------------|
| | | TO-220 - TO-247 | TO-220FP | |
| V_{DS} | Drain-source voltage ($V_{GS} = 0$) | 800 | | V |
| V_{GS} | Gate- source voltage | ± 30 | | V |
| I_D | Drain current (continuous) at $T_C = 25^\circ\text{C}$ | 6.2 | 6.2 ⁽¹⁾ | A |
| I_D | Drain current (continuous) at $T_C = 100^\circ\text{C}$ | 3.9 | 3.9 ⁽¹⁾ | A |
| $I_{DM}^{(2)}$ | Drain current (pulsed) | 24.8 | 24.8 ⁽¹⁾ | A |
| P_{TOT} | Total dissipation at $T_C = 25^\circ\text{C}$ | 140 | 30 | W |
| | Derating factor | 1.12 | 0.24 | W/ $^\circ\text{C}$ |
| $V_{ESD(G-S)}$ | Gate source ESD(HBM-C=100pF, R=1.5K Ω) | 4000 | | V |
| $dv/dt^{(3)}$ | Peak diode recovery voltage slope | 4.5 | | V/ns |
| V_{ISO} | Insulation withstand voltage (RMS) from all three leads to external heat sink (t=1s; $T_C = 25^\circ\text{C}$) | - | 2500 | V |
| T_j T_{stg} | Max operating Junction temperature Storage temperature | -55 to 150 | | $^\circ\text{C}$ |

1. Limited only by maximum temperature allowed
2. Pulse width limited by safe operating area
3. $I_{SD} \leq 6.2$ A, $di/dt \leq 200$ A/ μs , $V_{DD} \leq V_{(BR)DSS}$, $T_j \leq T_{JMAX}$.

Table 3. Thermal data

| Symbol | Parameter | Value | | | Unit |
|----------------|--|--------|----------|--------|---------------------------|
| | | TO-220 | TO-220FP | TO-247 | |
| $R_{thj-case}$ | Thermal resistance junction-case max | 0.89 | 4.2 | 0.89 | $^\circ\text{C}/\text{W}$ |
| $R_{thj-amb}$ | Thermal resistance junction-ambient max | 62.5 | | 50 | $^\circ\text{C}/\text{W}$ |
| T_l | Maximum lead temperature for soldering purpose | 300 | | | $^\circ\text{C}$ |

Table 4. Avalanche characteristics

| Symbol | Parameter | Value | Unit |
|----------|---|-------|------|
| I_{AR} | Avalanche current, repetitive or not-repetitive (pulse width limited by T_j Max) | 6.2 | A |
| E_{AS} | Single pulse avalanche energy (starting $T_j = 25^\circ\text{C}$, $I_d = I_{AR}$, $V_{dd} = 50\text{V}$) | 300 | mJ |

2 Electrical characteristics

($T_{CASE}=25^{\circ}C$ unless otherwise specified)

Table 5. On/off states

| Symbol | Parameter | Test conditions | Min. | Typ. | Max. | Unit |
|---------------|--|---|------|------|----------|--------------------|
| $V_{(BR)DSS}$ | Drain-source Breakdown voltage | $I_D = 1mA, V_{GS} = 0$ | 800 | | | V |
| I_{DSS} | Zero gate voltage Drain current ($V_{GS} = 0$) | $V_{DS} = \text{Max rating}$ $V_{DS} = \text{Max rating}, @125^{\circ}C$ | | | 1 50 | μA μA |
| I_{GSS} | Gate-body leakage Current ($V_{DS} = 0$) | $V_{GS} = \pm 20 V$ | | | ± 10 | μA |
| $V_{GS(th)}$ | Gate threshold voltage | $V_{DS} = V_{GS}, I_D = 100 \mu A$ | 3 | 3.75 | 4.5 | V |
| $R_{DS(on)}$ | Static drain-source on resistance | $V_{GS} = 10 V, I_D = 3.1 A$ | | 1.3 | 1.5 | Ω |

Table 6. Dynamic

| Symbol | Parameter | Test conditions | Min. | Typ. | Max. | Unit |
|---------------------|-------------------------------|---|------|------|------|------|
| $g_{fs}^{(1)}$ | Forward transconductance | $V_{DS} = 15V, I_D = 3.1 A$ | | 5.2 | | S |
| C_{iss} | Input capacitance | $V_{DS} = 25 V, f = 1 MHz,$ $V_{GS} = 0$ | | 1320 | | pF |
| C_{oss} | Output capacitance | | | 143 | | pF |
| C_{rss} | Reverse transfer capacitance | | | 27 | | pF |
| $C_{oss eq.}^{(2)}$ | Equivalent output capacitance | $V_{DS} = 0V, V_{DS} = 0V \text{ to } 640V$ | | 58 | | pF |
| $t_{d(on)}$ | Turn-on delay time | $V_{DD} = 400 V, I_D = 3.1 A,$ $R_G = 4.7 \Omega, V_{GS} = 10 V$ (see Figure 21) | | 17 | | ns |
| t_r | Rise time | | | 30 | | ns |
| $t_{r(off)}$ | Turn-off delay time | | | 48 | | ns |
| t_f | Fall time | | | 28 | | ns |
| Q_g | Total gate charge | $V_{DD} = 640 V, I_D = 6.2 A,$ $V_{GS} = 10 V$ | | 46 | | nC |
| Q_{gs} | Gate-source charge | | | 8.5 | | nC |
| Q_{gd} | Gate-drain charge | | | 25 | | nC |
| $t_{r(Voff)}$ | Off-voltage rise time | $V_{DD} = 640 V, I_D = 6.2 A,$ $R_G = 4.7 \Omega, V_{GS} = 10 V$ (see Figure 23) | | 9 | | ns |
| t_f | Fall time | | | 9 | | ns |
| t_c | Cross-over time | | | 18 | | ns |

1. Pulsed: pulse duration=300 μs , duty cycle 1.5%

2. $C_{oss eq.}$ is defined as a constant equivalent capacitance giving the same charging time as C_{oss} when V_{DS} increases from 0 to 80% V_{DSS} .

Table 7. Source drain diode

| Symbol | Parameter | Test conditions | Min. | Typ. | Max. | Unit |
|-----------------|-------------------------------|---|------|------|------|------|
| I_{SD} | Source-drain current | | | | 6.2 | A |
| $I_{SDM}^{(1)}$ | Source-drain current (pulsed) | | | | 24.8 | A |
| $V_{SD}^{(2)}$ | Forward on voltage | $I_{SD} = 6.2 \text{ A}, V_{GS} = 0$ | | | 1.6 | V |
| t_{rr} | Reverse recovery time | $I_{SD} = 6.2 \text{ A}, di/dt = 100 \text{ A}/\mu\text{s}$ | | 460 | | ns |
| Q_{rr} | Reverse recovery charge | $V_{DD} = 50 \text{ V}, T_j = 150^\circ\text{C}$ | | 2990 | | nC |
| I_{RRM} | Reverse recovery current | (see Figure 23) | | 13 | | A |

1. Pulsed: pulse duration=300 μs , duty cycle 1.5%
2. Pulse width limited by safe operating area

Table 8. Gate-source zener diode

| Symbol | Parameter | Test conditions | Min. | Typ. | Max. | Unit |
|------------------|-------------------------------|--|------|------|------|------|
| $BV_{GSO}^{(1)}$ | Gate-source breakdown voltage | $I_{gs} = \pm 1 \text{ mA}$ (Open Drain) | 30 | | | V |

1. The built-in back-to-back Zener diodes have specifically been designed to enhance not only the device's ESD capability, but also to make them safely absorb possible voltage transients that may occasionally be applied from gate to source. In this respect the Zener voltage is appropriate to achieve an efficient and cost-effective intervention to protect the device's integrity. These integrated Zener diodes thus avoid the usage of external components.

2.1 Electrical characteristics (curves)

Figure 2. Safe operating area for TO-220

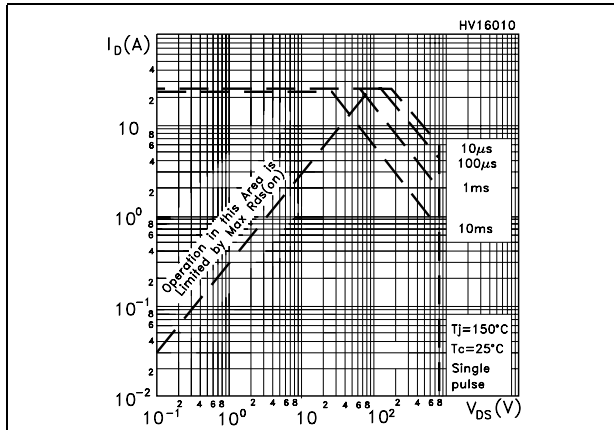

Figure 3. Thermal impedance for TO-220

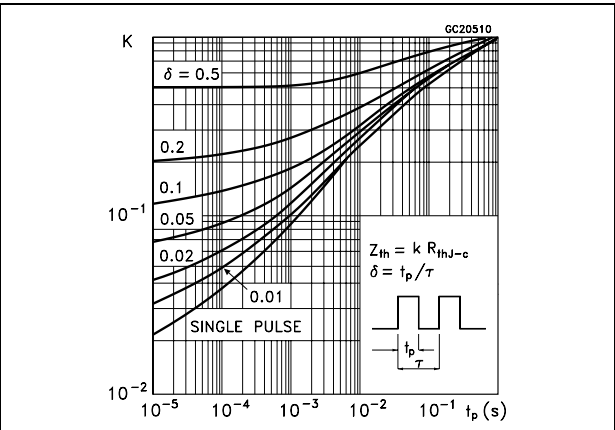

Figure 4. Safe operating area for TO-220FP

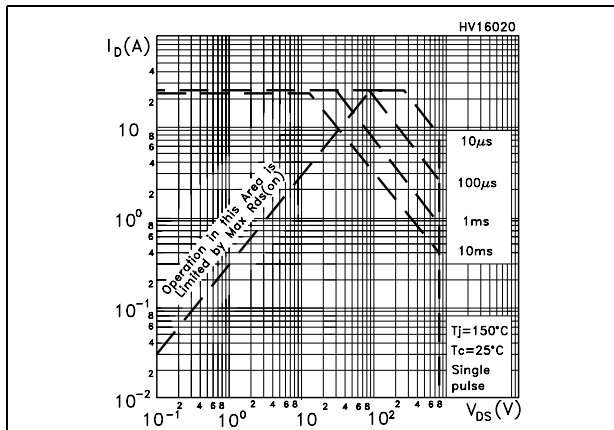

Figure 5. Thermal impedance for TO-220FP

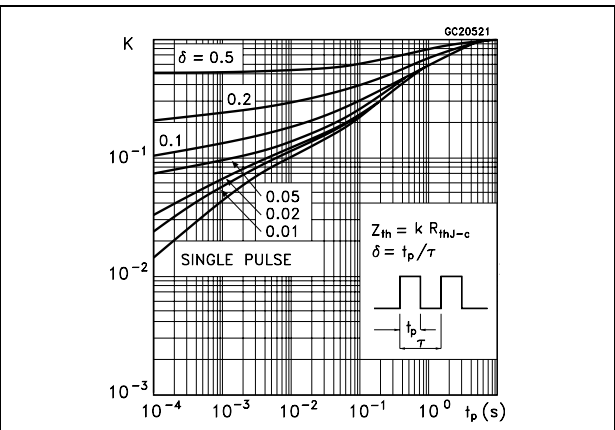

Figure 6. Safe operating area for TO-247

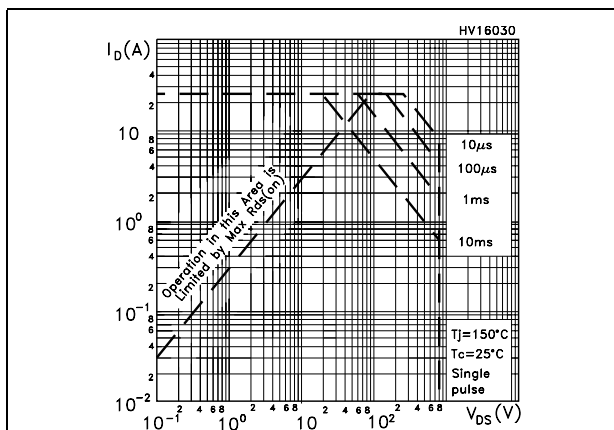

Figure 7. Thermal impedance for TO-247

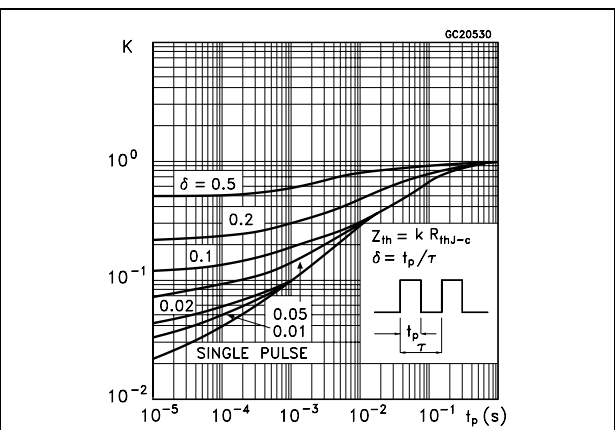

Figure 8. Output characteristics

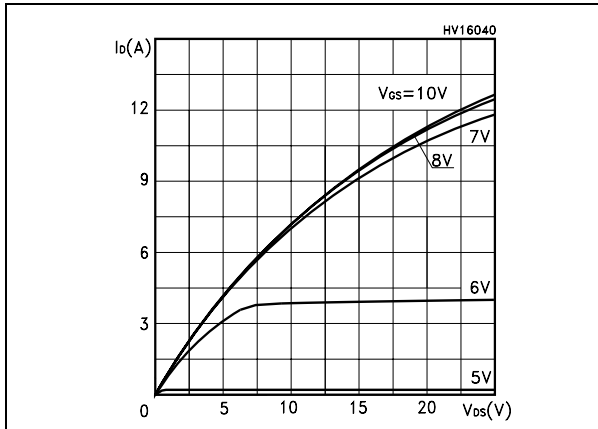

Figure 9. Transfer characteristics

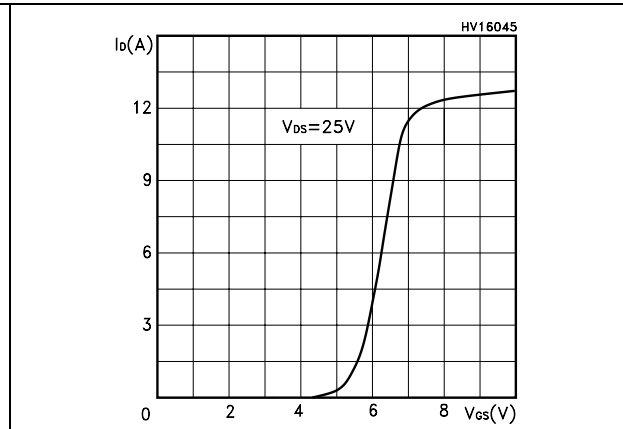

Figure 10. Transconductance

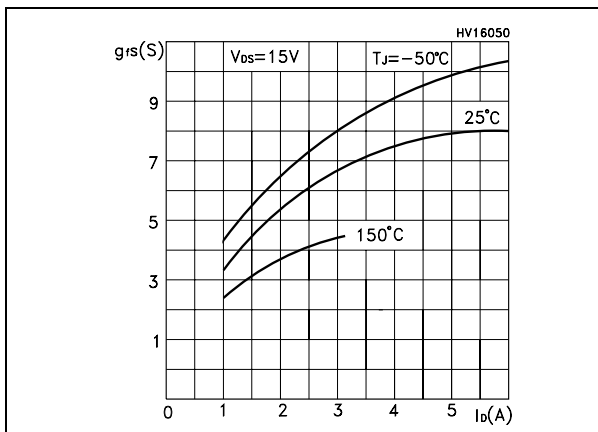

Figure 11. Static drain-source on resistance

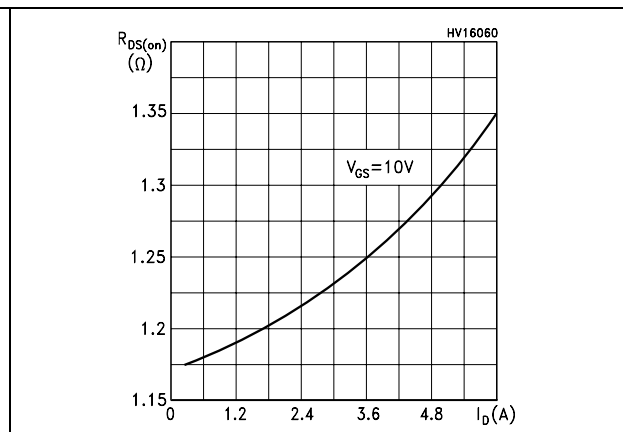

Figure 12. Gate charge vs gate-source voltage

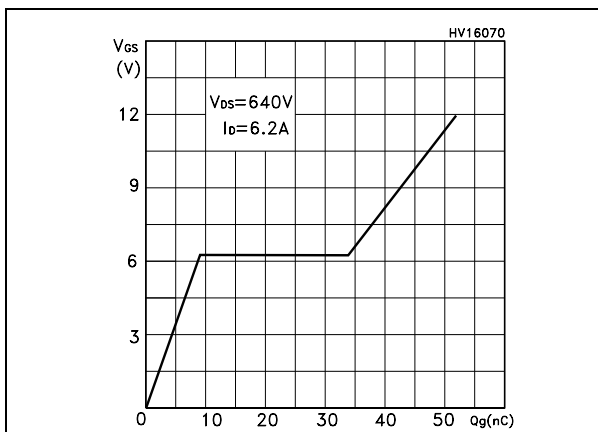

Figure 13. Capacitance variations

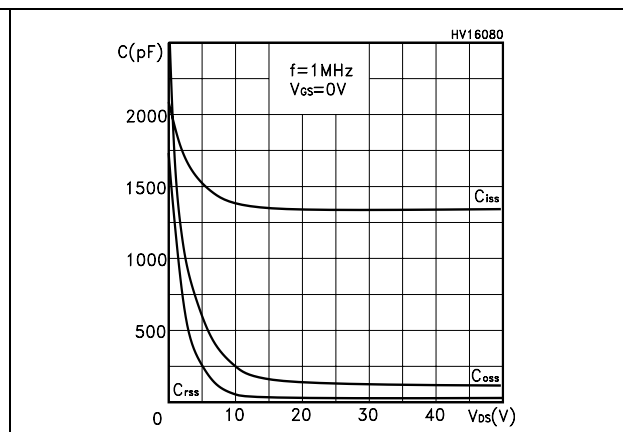

Figure 14. Normalized gate threshold voltage vs temperature

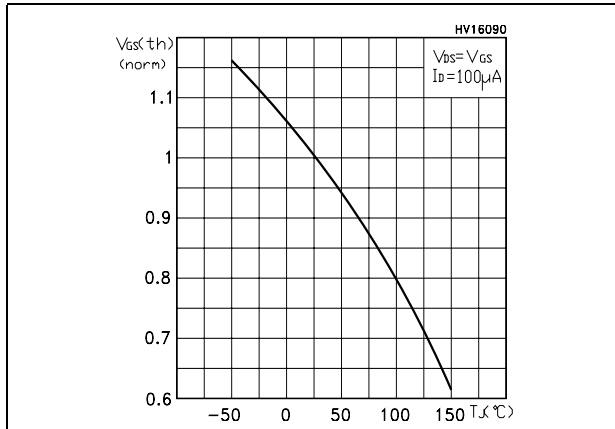

Figure 15. Normalized on resistance vs temperature

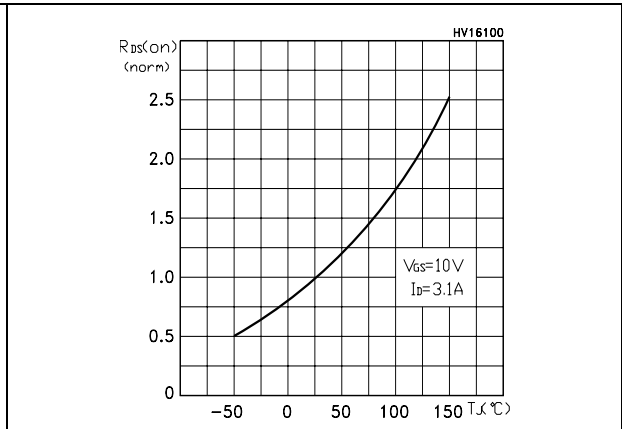

Figure 16. Source-drain diode forward characteristic

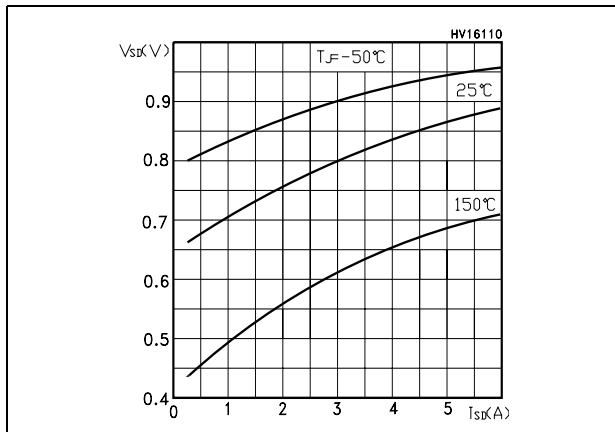

Figure 17. Normalized B_{VDS} vs temperature

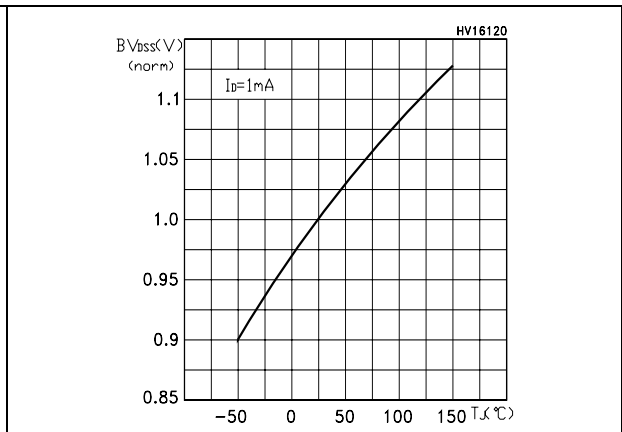
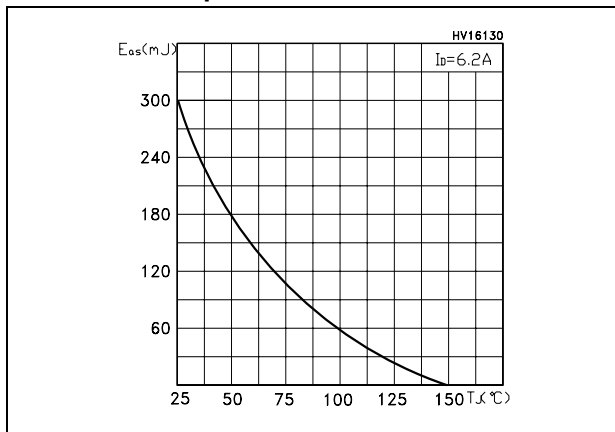

Figure 18. Maximum avalanche energy vs temperature



3 Test circuit

Figure 19. Unclamped inductive load test circuit

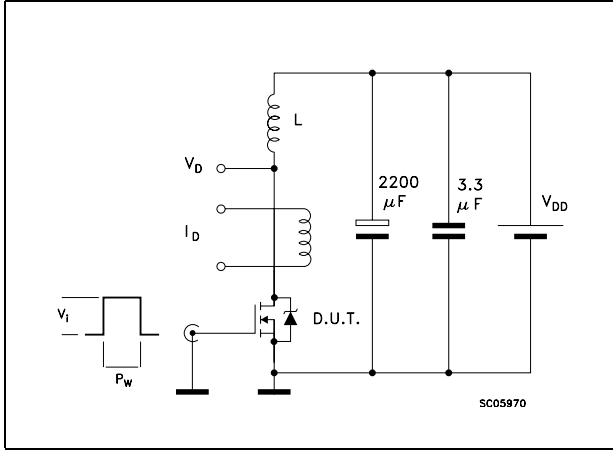

Figure 20. Unclamped inductive waveform

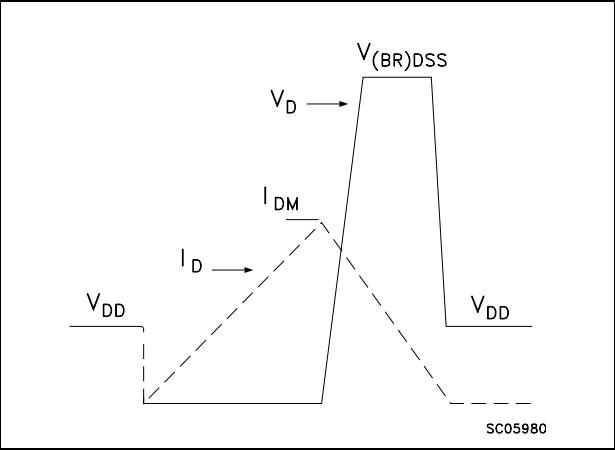

Figure 21. Switching times test circuit for resistive load

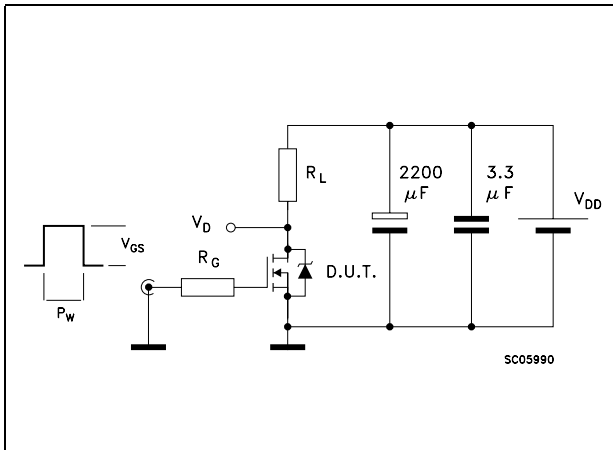

Figure 22. Gate charge test circuit

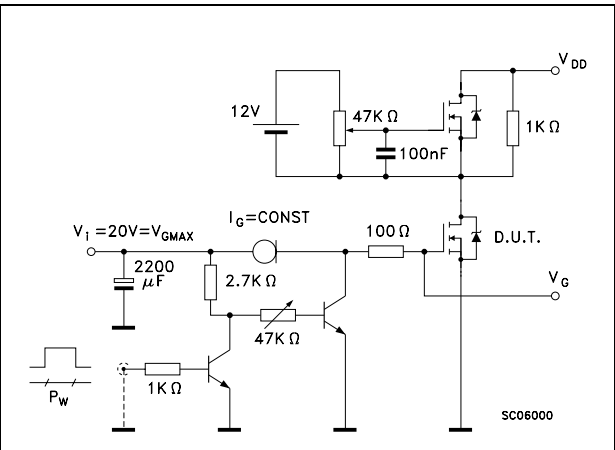
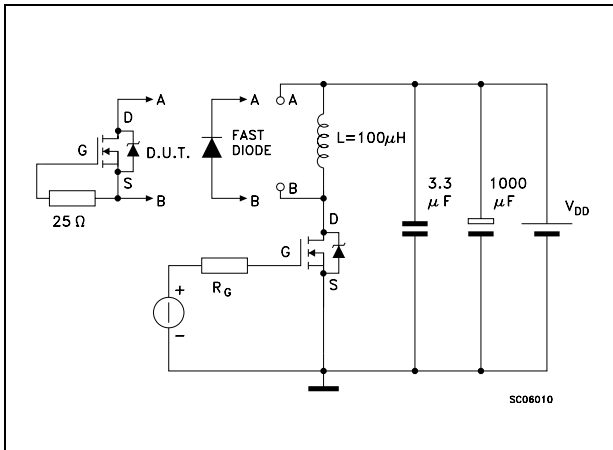

Figure 23. Test circuit for inductive load switching and diode recovery times



4 Package mechanical data

In order to meet environmental requirements, ST offers these devices in ECOPACK® packages. These packages have a Lead-free second level interconnect. The category of second level interconnect is marked on the package and on the inner box label, in compliance with JEDEC Standard JESD97. The maximum ratings related to soldering conditions are also marked on the inner box label. ECOPACK is an ST trademark. ECOPACK specifications are available at: www.st.com

TO-220 mechanical data

| Dim | mm | | | inch | | |
|-----|-------|-------|-------|-------|-------|-------|
| | Min | Typ | Max | Min | Typ | Max |
| A | 4.40 | | 4.60 | 0.173 | | 0.181 |
| b | 0.61 | | 0.88 | 0.024 | | 0.034 |
| b1 | 1.14 | | 1.70 | 0.044 | | 0.066 |
| c | 0.49 | | 0.70 | 0.019 | | 0.027 |
| D | 15.25 | | 15.75 | 0.6 | | 0.62 |
| D1 | | 1.27 | | | 0.050 | |
| E | 10 | | 10.40 | 0.393 | | 0.409 |
| e | 2.40 | | 2.70 | 0.094 | | 0.106 |
| e1 | 4.95 | | 5.15 | 0.194 | | 0.202 |
| F | 1.23 | | 1.32 | 0.048 | | 0.051 |
| H1 | 6.20 | | 6.60 | 0.244 | | 0.256 |
| J1 | 2.40 | | 2.72 | 0.094 | | 0.107 |
| L | 13 | | 14 | 0.511 | | 0.551 |
| L1 | 3.50 | | 3.93 | 0.137 | | 0.154 |
| L20 | | 16.40 | | | 0.645 | |
| L30 | | 28.90 | | | 1.137 | |
| ∅P | 3.75 | | 3.85 | 0.147 | | 0.151 |
| Q | 2.65 | | 2.95 | 0.104 | | 0.116 |

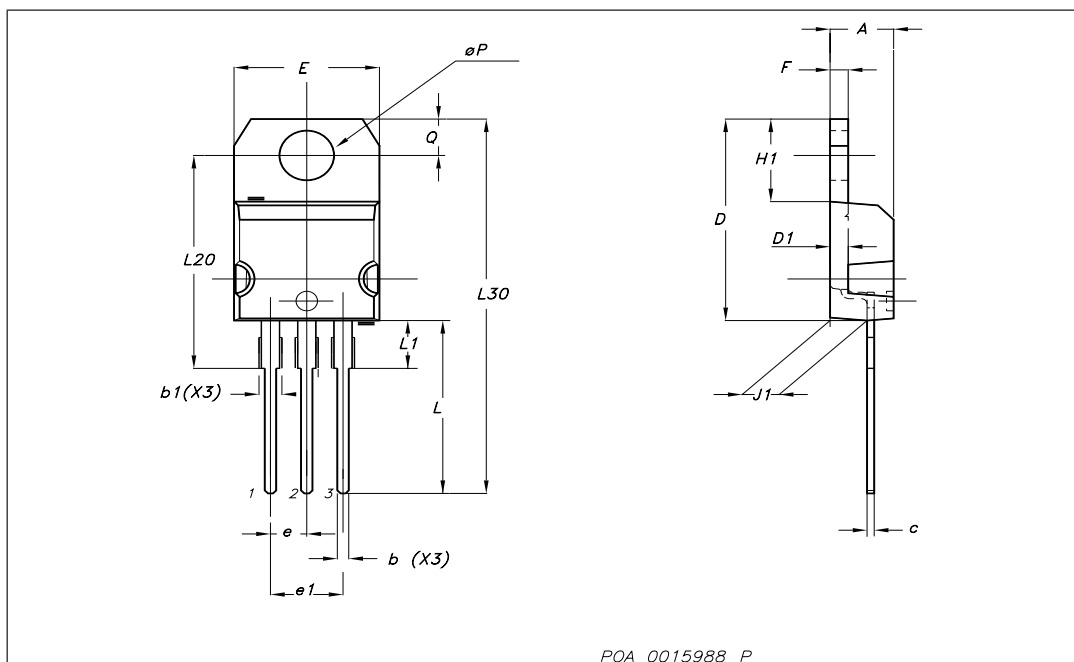

TO-220FP MECHANICAL DATA

| DIM. | mm. | | | inch | | |
|------|------|-----|------|-------|-------|-------|
| | MIN. | TYP | MAX. | MIN. | TYP. | MAX. |
| A | 4.4 | | 4.6 | 0.173 | | 0.181 |
| B | 2.5 | | 2.7 | 0.098 | | 0.106 |
| D | 2.5 | | 2.75 | 0.098 | | 0.108 |
| E | 0.45 | | 0.7 | 0.017 | | 0.027 |
| F | 0.75 | | 1 | 0.030 | | 0.039 |
| F1 | 1.15 | | 1.7 | 0.045 | | 0.067 |
| F2 | 1.15 | | 1.7 | 0.045 | | 0.067 |
| G | 4.95 | | 5.2 | 0.195 | | 0.204 |
| G1 | 2.4 | | 2.7 | 0.094 | | 0.106 |
| H | 10 | | 10.4 | 0.393 | | 0.409 |
| L2 | | 16 | | | 0.630 | |
| L3 | 28.6 | | 30.6 | 1.126 | | 1.204 |
| L4 | 9.8 | | 10.6 | .0385 | | 0.417 |
| L5 | 2.9 | | 3.6 | 0.114 | | 0.141 |
| L6 | 15.9 | | 16.4 | 0.626 | | 0.645 |
| L7 | 9 | | 9.3 | 0.354 | | 0.366 |
| Ø | 3 | | 3.2 | 0.118 | | 0.126 |

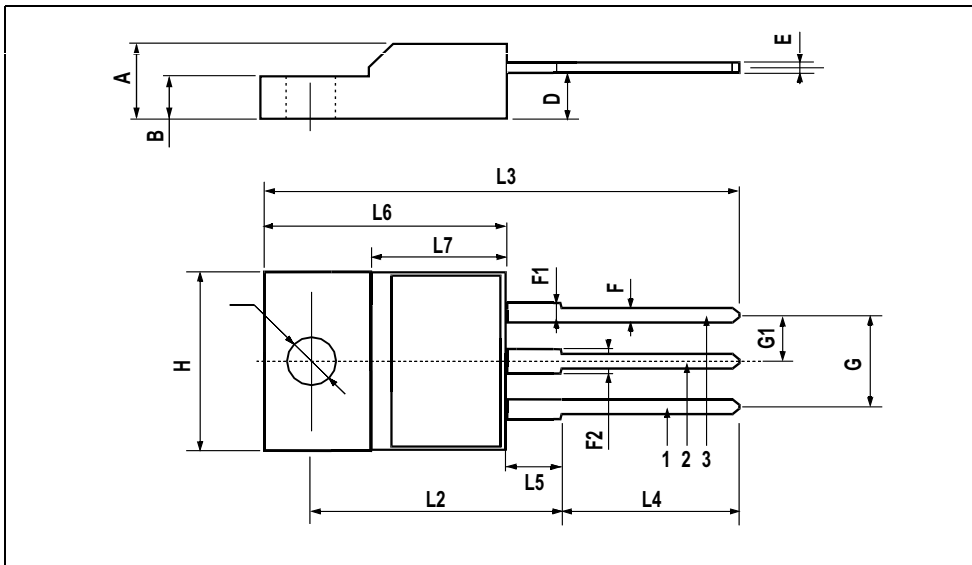

TO-247 MECHANICAL DATA

| DIM. | mm. | | | inch | | |
|------|-------|-------|-------|-------|-------|-------|
| | MIN. | TYP. | MAX. | MIN. | TYP. | MAX. |
| A | 4.85 | | 5.15 | 0.19 | | 0.20 |
| A1 | 2.20 | | 2.60 | 0.086 | | 0.102 |
| b | 1.0 | | 1.40 | 0.039 | | 0.055 |
| b1 | 2.0 | | 2.40 | 0.079 | | 0.094 |
| b2 | 3.0 | | 3.40 | 0.118 | | 0.134 |
| c | 0.40 | | 0.80 | 0.015 | | 0.03 |
| D | 19.85 | | 20.15 | 0.781 | | 0.793 |
| E | 15.45 | | 15.75 | 0.608 | | 0.620 |
| e | | 5.45 | | | 0.214 | |
| L | 14.20 | | 14.80 | 0.560 | | 0.582 |
| L1 | 3.70 | | 4.30 | 0.14 | | 0.17 |
| L2 | | 18.50 | | | 0.728 | |
| øP | 3.55 | | 3.65 | 0.140 | | 0.143 |
| øR | 4.50 | | 5.50 | 0.177 | | 0.216 |
| S | | 5.50 | | | 0.216 | |

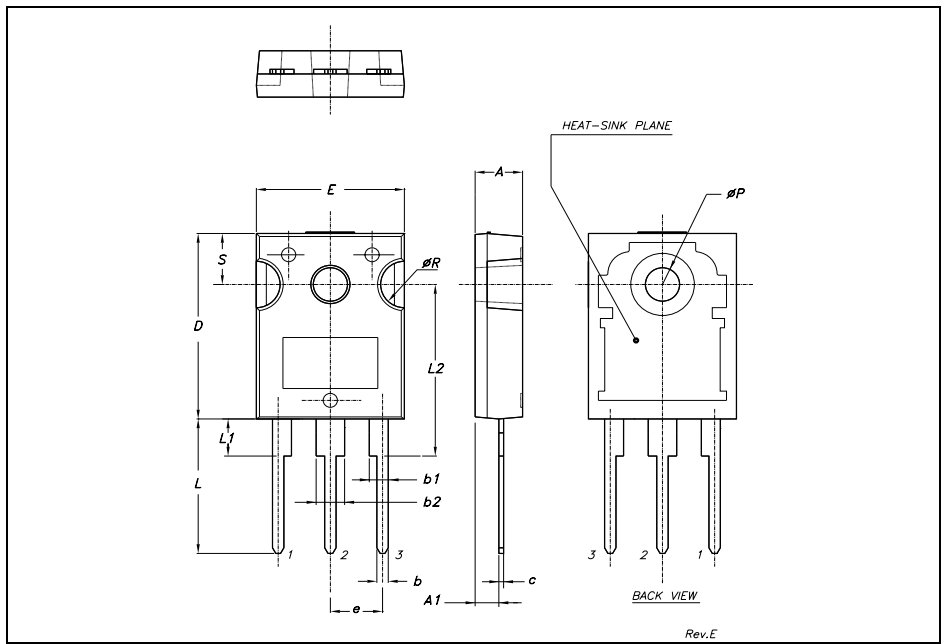

5 Revision history

Table 9. Revision history

| Date | Revision | Changes |
|-------------|----------|--|
| 09-Sep-2004 | 2 | Complete version |
| 17-Aug-2006 | 3 | New template, no content change |
| 20-Apr-2007 | 4 | Typo errors on Table 6 |
| 02-Jul-2007 | 5 | Table 2 has been updated |

Please Read Carefully:

Information in this document is provided solely in connection with ST products. STMicroelectronics NV and its subsidiaries ("ST") reserve the right to make changes, corrections, modifications or improvements, to this document, and the products and services described herein at any time, without notice.

All ST products are sold pursuant to ST's terms and conditions of sale.

Purchasers are solely responsible for the choice, selection and use of the ST products and services described herein, and ST assumes no liability whatsoever relating to the choice, selection or use of the ST products and services described herein.

No license, express or implied, by estoppel or otherwise, to any intellectual property rights is granted under this document. If any part of this document refers to any third party products or services it shall not be deemed a license grant by ST for the use of such third party products or services, or any intellectual property contained therein or considered as a warranty covering the use in any manner whatsoever of such third party products or services or any intellectual property contained therein.

UNLESS OTHERWISE SET FORTH IN ST'S TERMS AND CONDITIONS OF SALE ST DISCLAIMS ANY EXPRESS OR IMPLIED WARRANTY WITH RESPECT TO THE USE AND/OR SALE OF ST PRODUCTS INCLUDING WITHOUT LIMITATION IMPLIED WARRANTIES OF MERCHANTABILITY, FITNESS FOR A PARTICULAR PURPOSE (AND THEIR EQUIVALENTS UNDER THE LAWS OF ANY JURISDICTION), OR INFRINGEMENT OF ANY PATENT, COPYRIGHT OR OTHER INTELLECTUAL PROPERTY RIGHT.

UNLESS EXPRESSLY APPROVED IN WRITING BY AN AUTHORIZED ST REPRESENTATIVE, ST PRODUCTS ARE NOT RECOMMENDED, AUTHORIZED OR WARRANTED FOR USE IN MILITARY, AIR CRAFT, SPACE, LIFE SAVING, OR LIFE SUSTAINING APPLICATIONS, NOR IN PRODUCTS OR SYSTEMS WHERE FAILURE OR MALFUNCTION MAY RESULT IN PERSONAL INJURY, DEATH, OR SEVERE PROPERTY OR ENVIRONMENTAL DAMAGE. ST PRODUCTS WHICH ARE NOT SPECIFIED AS "AUTOMOTIVE GRADE" MAY ONLY BE USED IN AUTOMOTIVE APPLICATIONS AT USER'S OWN RISK.

Resale of ST products with provisions different from the statements and/or technical features set forth in this document shall immediately void any warranty granted by ST for the ST product or service described herein and shall not create or extend in any manner whatsoever, any liability of ST.

ST and the ST logo are trademarks or registered trademarks of ST in various countries.

Information in this document supersedes and replaces all information previously supplied.

The ST logo is a registered trademark of STMicroelectronics. All other names are the property of their respective owners.

© 2007 STMicroelectronics - All rights reserved



STMicroelectronics group of companies

Australia - Belgium - Brazil - Canada - China - Czech Republic - Finland - France - Germany - Hong Kong - India - Israel - Italy - Japan - Malaysia - Malta - Morocco - Singapore - Spain - Sweden - Switzerland - United Kingdom - United States of America

www.st.com

Looking for pricing, stock, or lifecycle information?

Click below to explore more details on WIN SOURCE:

-  [View STP8NK80ZFP](#) on WIN SOURCE
-  [STMicroelectronics](#) Information

Optimize Your Supply Chain with WIN SOURCE Solutions

-  Global Sourcing Solution
-  Obsolete Management
-  Cost Control Management
-  Shortage Management
-  Alternative Solution
-  Excess Inventory Management