



**THE DATASHEET OF
STQ1NC45R-AP**





STD2NC45-1 STQ1NC45R-AP

N-channel 450V - 4.1Ω - 1.5A - IPAK - TO-92
SuperMESH™ Power MOSFET

General features

Type	V _{DSS}	R _{DS(on)}	I _D	P _w
STD2NC45-1	450V	<4.5Ω	1.5A	30W
STQ1NC45R-AP	450V	<4.5Ω	0.5A	3.1W

- Extremely high dv/dt capability
- 100% avalanche tested
- Gate charge minimized
- New high voltage benchmark

Description

The SuperMESH™ series is obtained through an extreme optimization of ST's well established strip-based PowerMESH™ layout. In addition to pushing on-resistance significantly down, special care is taken to ensure a very good dv/dt capability for the most demanding applications. Such series complements ST full range of high voltage Power MOSFETs including revolutionary MDmesh™ products.

Applications

- Switching application
 - Switch mode low power supplies (SMPS)
 - Low power, low cost CFL (compact fluorescent lamps)
 - Low power battery chargers

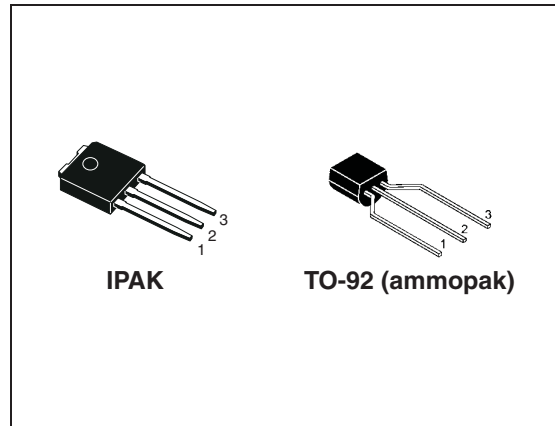

Internal schematic diagram

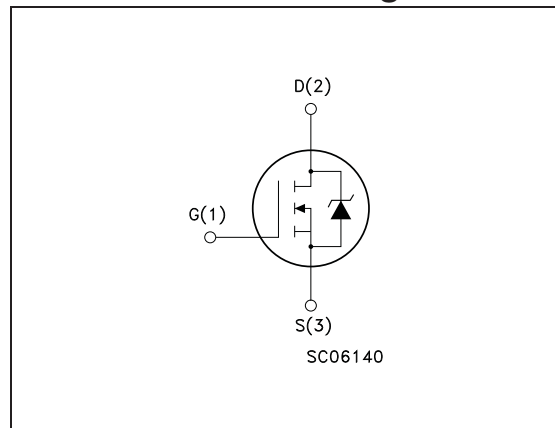

Order codes

Part number	Marking	Package	Packaging
STD2NC45-1	D2NC45	IPAK	Tube
STQ1NC45R-AP	Q1NC45R	TO-92	Ammopak

Contents

1	Electrical ratings	3
2	Electrical characteristics	4
	2.1 Electrical characteristics (curves)	6
3	Test circuit	9
4	Package mechanical data	10
5	Revision history	14

1 Electrical ratings

Table 1. Absolute maximum ratings

Symbol	Parameter	Value		Unit
		IPAK	TO-92	
V_{DS}	Drain-source voltage ($V_{GS} = 0$)	450		V
V_{GS}	Gate- source voltage	± 30		V
I_D	Drain current (continuous) at $T_C = 25^\circ\text{C}$	1.5	0.5	A
I_D	Drain current (continuous) at $T_C = 100^\circ\text{C}$	0.95	0.315	A
$I_{DM}^{(1)}$	Drain current (pulsed)	6	2	A
P_{TOT}	Total dissipation at $T_C = 25^\circ\text{C}$	30	3.1	W
	Derating factor	0.24	0.025	W/ $^\circ\text{C}$
$dv/dt^{(2)}$	Peak diode recovery voltage slope	3		V/ns
T_{stg}	Storage temperature	-65 to 150		$^\circ\text{C}$
T_j	Max. operating junction temperature			$^\circ\text{C}$

1. Pulse width limited by safe operating area

2. $I_{SD} \leq 0.5\text{A}$, $di/dt \leq 100\text{ A}/\mu\text{s}$, $V_{DD} = 80\% V_{(BR)DSS}$

Table 2. Thermal data

Symbol	Parameter	Value		Unit
		IPAK	TO-92	
$R_{thj-case}$	Thermal resistance junction-case max	4.1	--	$^\circ\text{C}/\text{W}$
$R_{thj-amb}$	Thermal resistance junction-ambient max	100	120	$^\circ\text{C}/\text{W}$
$R_{thj-lead}$	Thermal resistance junction-lead max	--	40	$^\circ\text{C}/\text{W}$
T_l	Maximum lead temperature for soldering purpose	275	260	$^\circ\text{C}$

Table 3. Avalanche characteristics

Symbol	Parameter	Value	Unit
I_{AS}	Avalanche current, repetitive or not-repetitive (pulse width limited by T_j Max)	1.5	A
E_{AS}	Single pulse avalanche energy (starting $T_j=25^\circ\text{C}$, $I_D=I_{AS}$, $V_{DD}=50\text{V}$)	25	mJ

2 Electrical characteristics

($T_{CASE} = 25^{\circ}C$ unless otherwise specified)

Table 4. On/off states

Symbol	Parameter	Test conditions	Min.	Typ.	Max.	Unit
$V_{(BR)DSS}$	Drain-source breakdown voltage	$I_D = 250\mu A, V_{GS} = 0$	450			V
I_{DSS}	Zero gate voltage Drain current ($V_{GS} = 0$)	$V_{DS} = \text{Max rating}$ $V_{DS} = \text{Max rating}, T_C = 125^{\circ}C$			1 50	μA μA
I_{GSS}	Gate-body leakage current ($V_{DS} = 0$)	$V_{GS} = \pm 30V$			± 100	nA
$V_{GS(th)}$	Gate threshold voltage	$V_{DS} = V_{GS}, I_D = 250\mu A$	2.3	3	3.7	V
$R_{DS(on)}$	Static drain-source on resistance	$V_{GS} = 10V, I_D = 0.5A$		4.1	4.5	Ω

Table 5. Dynamic

Symbol	Parameter	Test conditions	Min.	Typ.	Max.	Unit
$g_{fs}^{(1)}$	Forward transconductance	$V_{DS} > I_{D(on)} \times R_{DS(on)max},$ $I_D = 0.5A$		1.1		S
C_{iss} C_{oss} C_{rss}	Input capacitance Output capacitance Reverse transfer capacitance	$V_{DS} = 25V, f = 1 \text{ MHz}, V_{GS} = 0$		160 27.5 4.7		pF pF pF
Q_g Q_{gs} Q_{gd}	Total gate charge Gate-source charge Gate-drain charge	$V_{DD} = 360V, I_D = 1.5A,$ $V_{GS} = 10V, R_G = 4.7\Omega$ (see Figure 18)		7 1.3 3.2	10	nC nC nC

1. Pulsed: pulse duration = 300 μs , duty cycle 1.5 %

Table 6. Switching times

Symbol	Parameter	Test conditions	Min.	Typ.	Max.	Unit
$t_{d(on)}$	Turn-on delay time	$V_{DD} = 225V, I_D = 0.5A$ $R_G = 4.7\Omega, V_{GS} = 10V$ (see Figure 17)		6.7		ns
t_r	Rise time			4		ns
$t_{r(voff)}$	Off-voltage rise time	$V_{DD} = 360V, I_D = 1.5A,$ $R_G = 4.7\Omega, V_{GS} = 10V$ (see Figure 17)		8.5		ns
t_f	Fall time			12		ns
t_c	Cross-over time			18		ns

Table 7. Source drain diode

Symbol	Parameter	Test conditions	Min	Typ.	Max	Unit
I_{SD}	Source-drain current				1.5	A
$I_{SDM}^{(1)}$	Source-drain current (pulsed)				6.0	A
$V_{SD}^{(2)}$	Forward on voltage	$I_{SD} = 1.5A, V_{GS} = 0$			1.6	V
t_{rr}	Reverse recovery time	$I_{SD} = 1.5A, di/dt = 100A/\mu s$ $V_{DD} = 100V, T_j = 150^\circ C$ (see Figure 22)		225		ns
Q_{rr}	Reverse recovery charge			530		μC
I_{RRM}	Reverse recovery current			4.7		A

1. Pulse width limited by safe operating area.
2. Pulsed: pulse duration = 300 μs , duty cycle 1.5 %

2.1 Electrical characteristics (curves)

Figure 1. Safe operating area for IPAK

Figure 2. Thermal impedance for IPAK

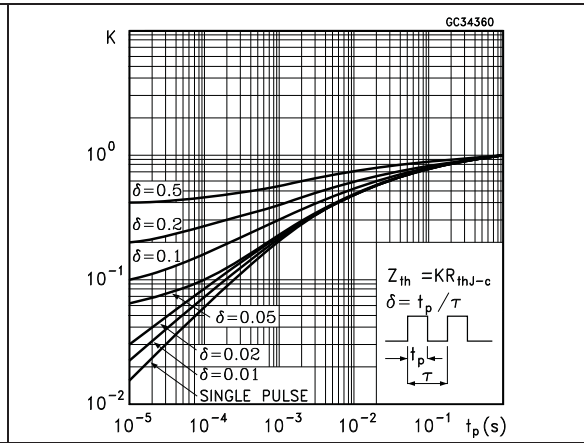
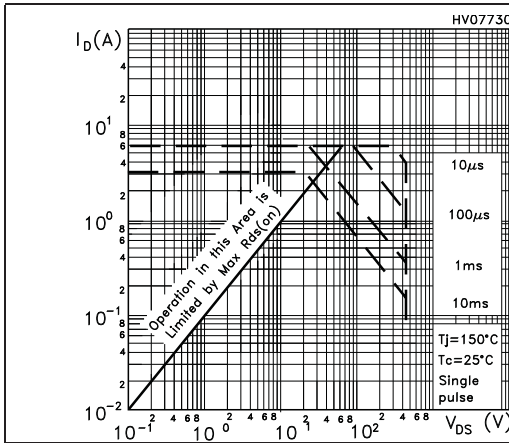

Figure 3. Safe operating area for TO-92

Figure 4. Thermal impedance for TO-92

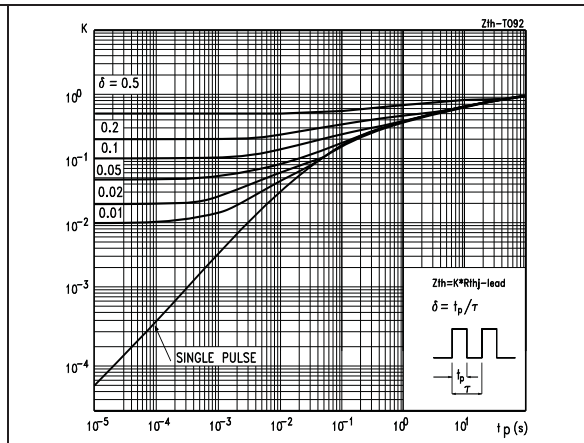
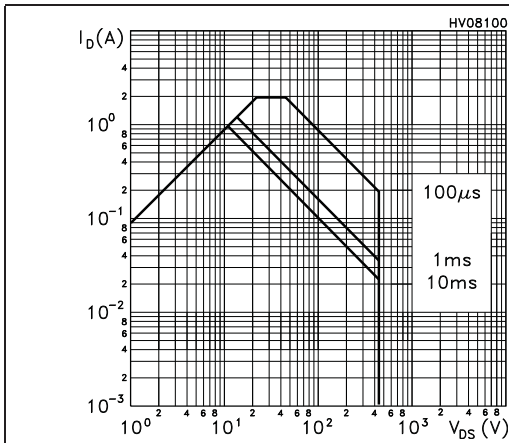

Figure 5. Output characteristics

Figure 6. Transfer characteristics

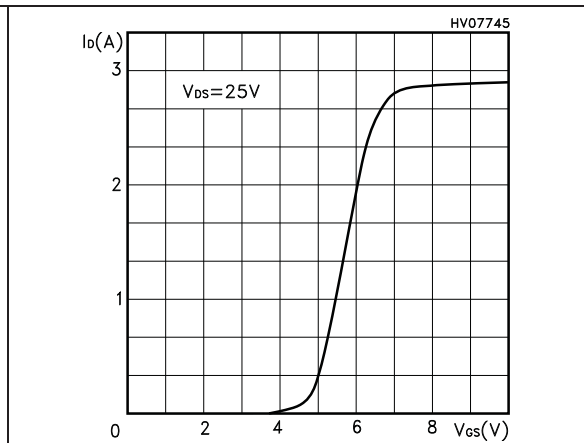
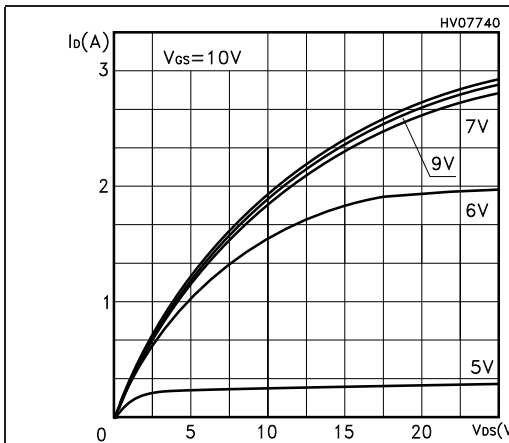

Figure 7. Transconductance

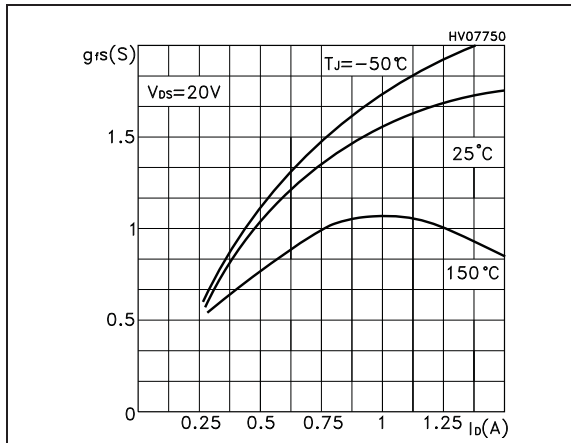

Figure 8. Static drain-source on resistance

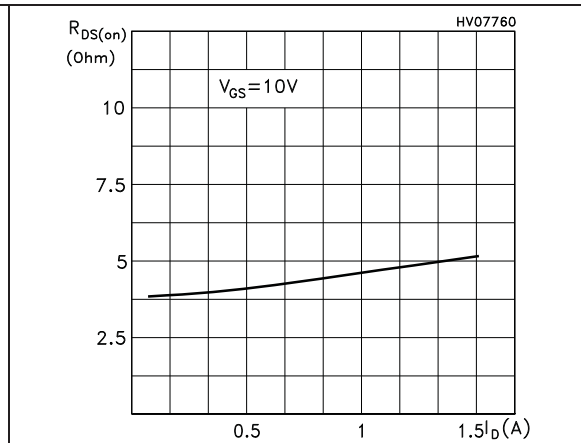

Figure 9. Gate charge vs gate-source voltage Figure 10. Capacitance variations

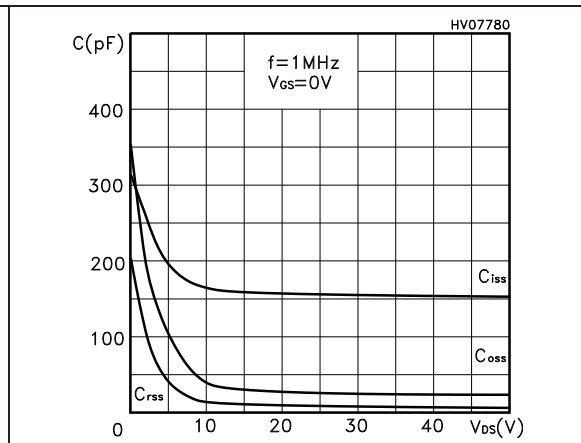
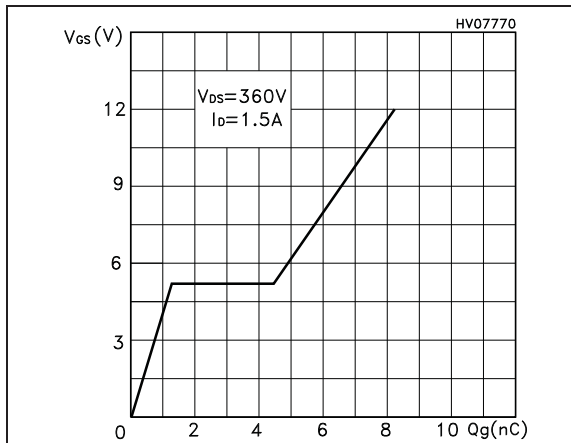

Figure 11. Normalized gate threshold voltage vs temperature

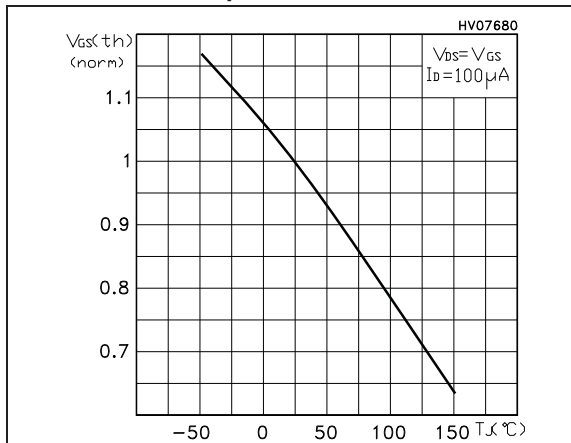

Figure 12. Normalized on resistance vs temperature

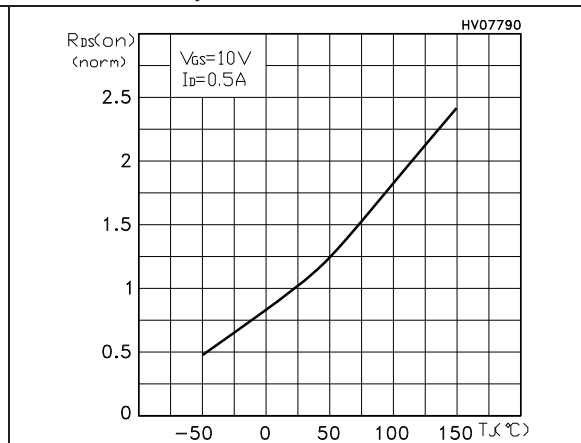

Figure 13. Source-drain diode forward characteristics

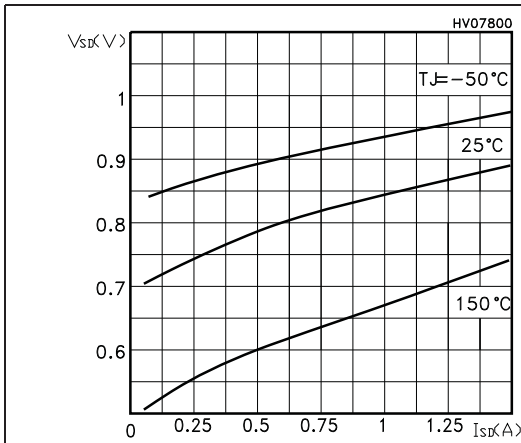

Figure 14. Normalized B_{VDSS} vs temperature

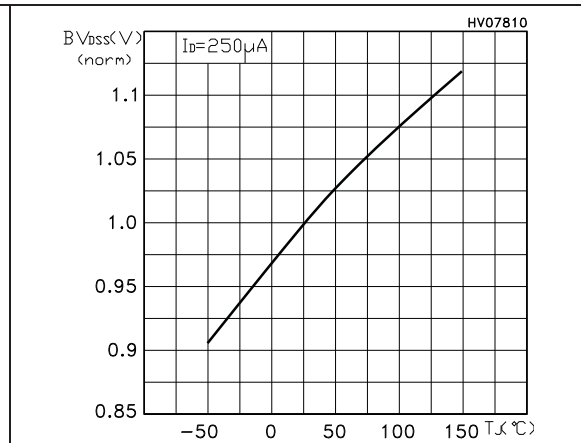

Figure 15. Max Id current vs Temperature

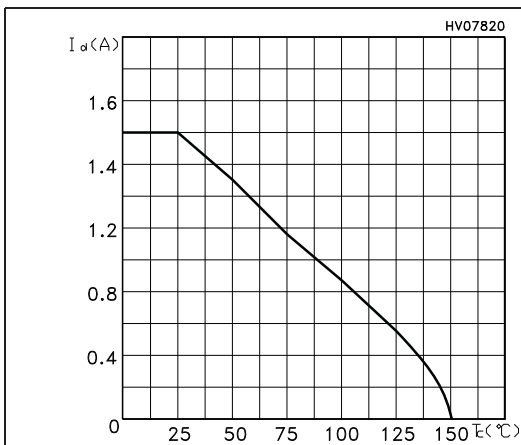
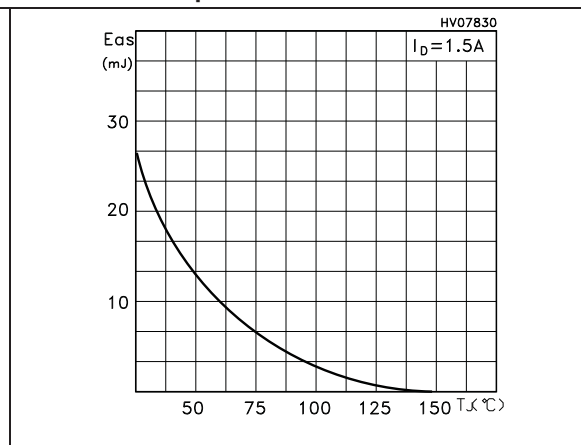

Figure 16. Maximum avalanche energy vs temperature



3 Test circuit

Figure 17. Switching times test circuit for resistive load

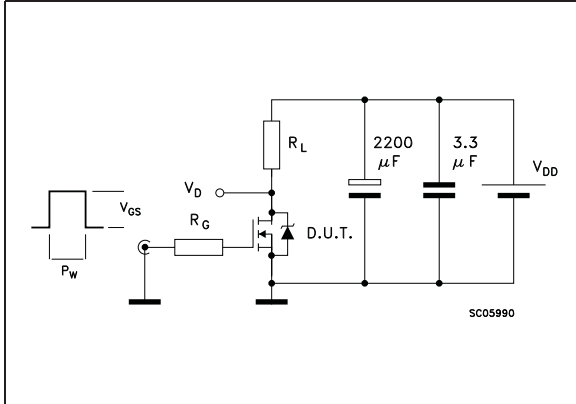

Figure 18. Gate charge test circuit

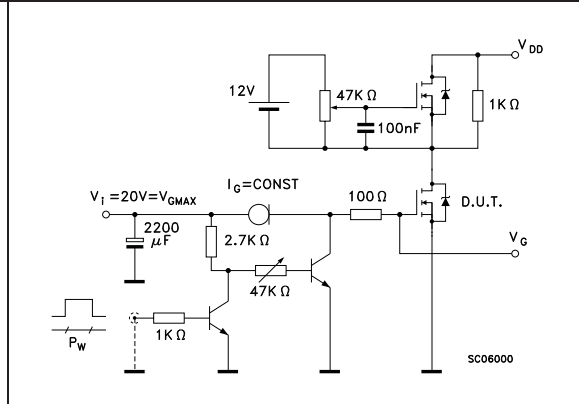

Figure 19. Test circuit for inductive load switching and diode recovery times

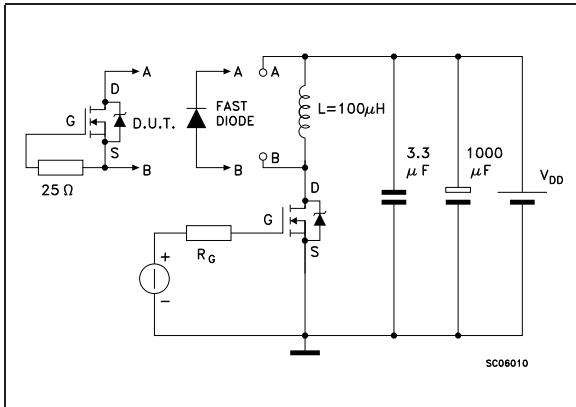

Figure 20. Unclamped Inductive load test circuit

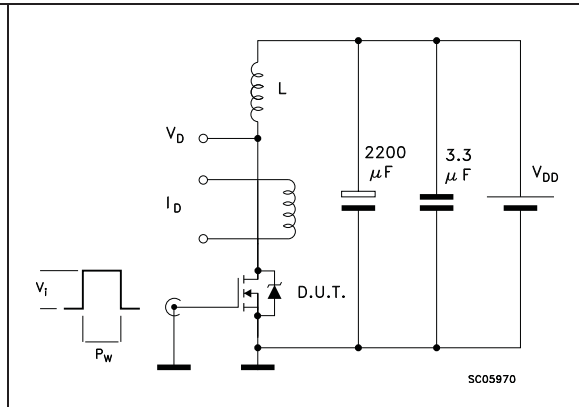
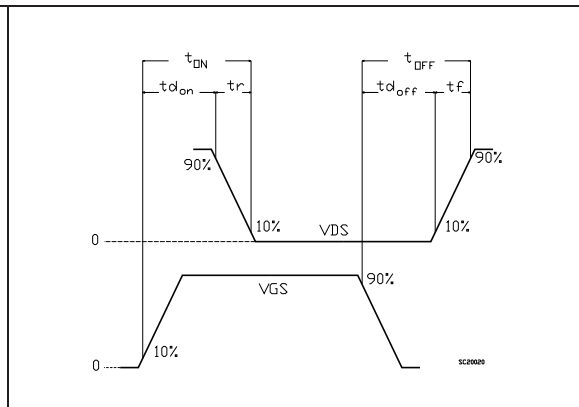
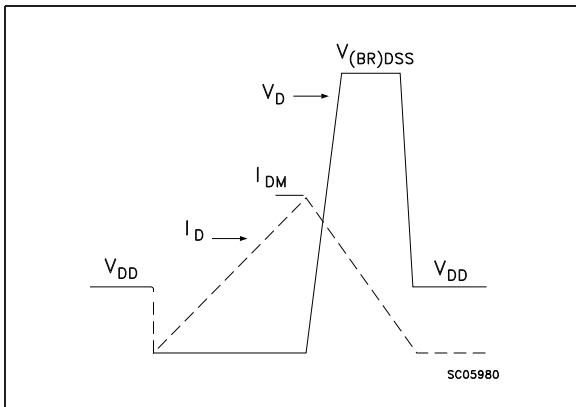

Figure 21. Unclamped inductive waveform

Figure 22. Switching time waveform



4 Package mechanical data

In order to meet environmental requirements, ST offers these devices in ECOPACK® packages. These packages have a Lead-free second level interconnect . The category of second level interconnect is marked on the package and on the inner box label, in compliance with JEDEC Standard JESD97. The maximum ratings related to soldering conditions are also marked on the inner box label. ECOPACK is an ST trademark. ECOPACK specifications are available at: www.st.com

TO-251 (IPAK) MECHANICAL DATA

DIM.	mm			inch		
	MIN.	TYP.	MAX.	MIN.	TYP.	MAX.
A	2.2		2.4	0.086		0.094
A1	0.9		1.1	0.035		0.043
A3	0.7		1.3	0.027		0.051
B	0.64		0.9	0.025		0.031
B2	5.2		5.4	0.204		0.212
B3			0.85			0.033
B5		0.3			0.012	
B6			0.95			0.037
C	0.45		0.6	0.017		0.023
C2	0.48		0.6	0.019		0.023
D	6		6.2	0.236		0.244
E	6.4		6.6	0.252		0.260
G	4.4		4.6	0.173		0.181
H	15.9		16.3	0.626		0.641
L	9		9.4	0.354		0.370
L1	0.8		1.2	0.031		0.047
L2		0.8	1		0.031	0.039

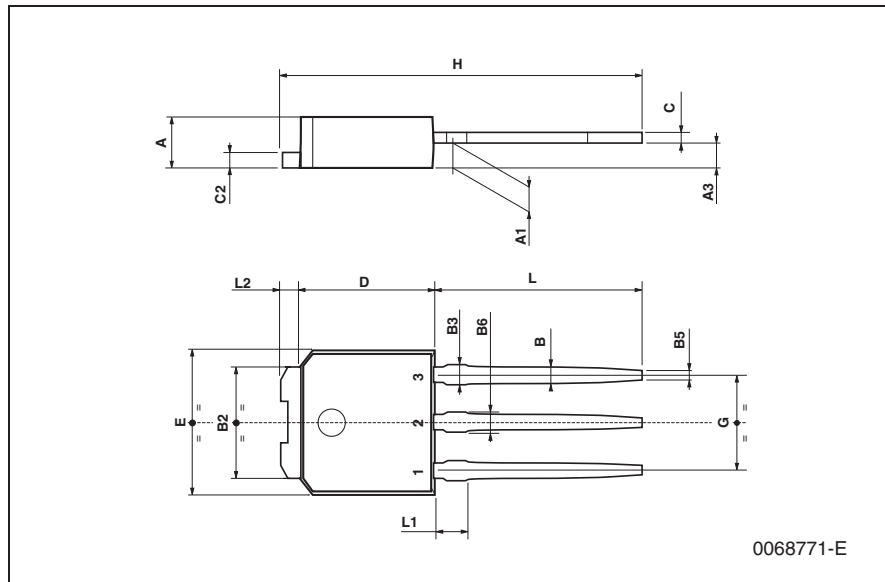

TO-92 MECHANICAL DATA

DIM.	mm.			inch		
	MIN.	TYP.	MAX.	MIN.	TYP.	MAX.
A	4.32		4.95	0.170		0.194
b	0.36		0.51	0.014		0.020
D	4.45		4.95	0.175		0.194
E	3.30		3.94	0.130		0.155
e	2.41		2.67	0.094		0.105
e1	1.14		1.40	0.044		0.055
L	12.70		15.49	0.50		0.610
R	2.16		2.41	0.085		0.094
S1	0.92		1.52	0.036		0.060
W	0.41		0.56	0.016		0.022
V		5°			5°	

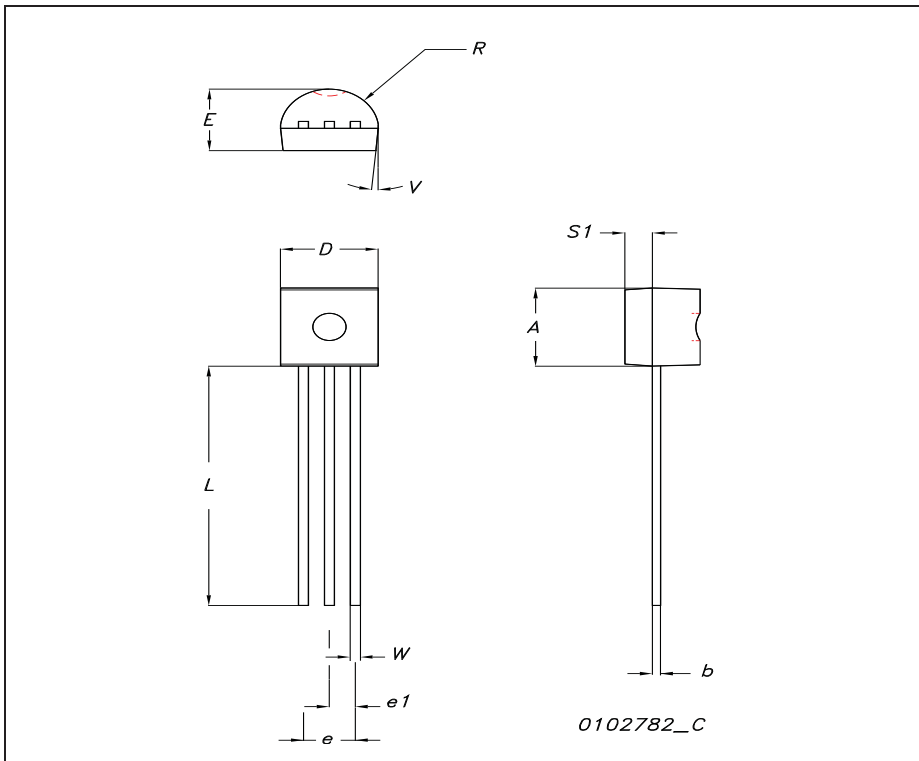

TO-92 AMMOPACK

DIM.	mm.			inch		
	MIN.	TYP.	MAX.	MIN.	TYP.	MAX.
A1	4.45		4.95	0.170		0.194
T	3.30		3.94	0.130		0.155
T1			1.6			0.06
T2			2.3			0.09
d	0.41		0.56	0.016		0.022
P0	12.5	12.7	12.9	0.49	0.5	0.51
P2	5.65	6.35	7.05	0.22	0.25	0.27
F1, F2	2.44	2.54	2.94	0.09	0.1	0.11
delta H	-2		2	-0.08		0.08
W	17.5	18	19	0.69	0.71	0.74
W0	5.7	6	6.3	0.22	0.23	0.24
W1	8.5	9	9.25	0.33	0.35	0.36
W2			0.5			0.02
H	18.5		20.5	0.72		0.80
H0	15.5	16	16.5	0.61	0.63	0.65
H1			25			0.98
D0	3.8	4	4.2	0.15	0.157	0.16
t			0.9			0.035
L			11			0.43
l1	3			0.11		
delta P	-1		1	-0.04		0.04

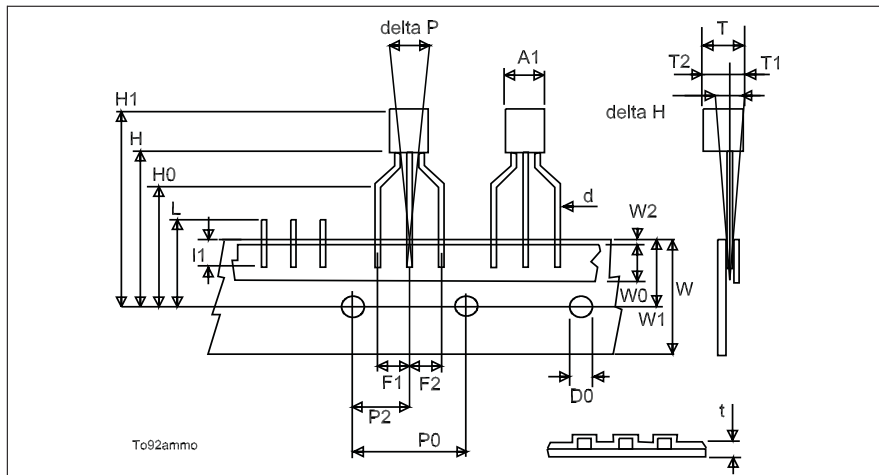

5 Revision history

Table 8. Revision history

Date	Revision	Changes
21-Jun-2004	2	Complete version
12-Jul-2006	3	New template

Please Read Carefully:

Information in this document is provided solely in connection with ST products. STMicroelectronics NV and its subsidiaries ("ST") reserve the right to make changes, corrections, modifications or improvements, to this document, and the products and services described herein at any time, without notice.

All ST products are sold pursuant to ST's terms and conditions of sale.

Purchasers are solely responsible for the choice, selection and use of the ST products and services described herein, and ST assumes no liability whatsoever relating to the choice, selection or use of the ST products and services described herein.

No license, express or implied, by estoppel or otherwise, to any intellectual property rights is granted under this document. If any part of this document refers to any third party products or services it shall not be deemed a license grant by ST for the use of such third party products or services, or any intellectual property contained therein or considered as a warranty covering the use in any manner whatsoever of such third party products or services or any intellectual property contained therein.

UNLESS OTHERWISE SET FORTH IN ST'S TERMS AND CONDITIONS OF SALE ST DISCLAIMS ANY EXPRESS OR IMPLIED WARRANTY WITH RESPECT TO THE USE AND/OR SALE OF ST PRODUCTS INCLUDING WITHOUT LIMITATION IMPLIED WARRANTIES OF MERCHANTABILITY, FITNESS FOR A PARTICULAR PURPOSE (AND THEIR EQUIVALENTS UNDER THE LAWS OF ANY JURISDICTION), OR INFRINGEMENT OF ANY PATENT, COPYRIGHT OR OTHER INTELLECTUAL PROPERTY RIGHT.

UNLESS EXPRESSLY APPROVED IN WRITING BY AN AUTHORIZED ST REPRESENTATIVE, ST PRODUCTS ARE NOT RECOMMENDED, AUTHORIZED OR WARRANTED FOR USE IN MILITARY, AIR CRAFT, SPACE, LIFE SAVING, OR LIFE SUSTAINING APPLICATIONS, NOR IN PRODUCTS OR SYSTEMS WHERE FAILURE OR MALFUNCTION MAY RESULT IN PERSONAL INJURY, DEATH, OR SEVERE PROPERTY OR ENVIRONMENTAL DAMAGE. ST PRODUCTS WHICH ARE NOT SPECIFIED AS "AUTOMOTIVE GRADE" MAY ONLY BE USED IN AUTOMOTIVE APPLICATIONS AT USER'S OWN RISK.

Resale of ST products with provisions different from the statements and/or technical features set forth in this document shall immediately void any warranty granted by ST for the ST product or service described herein and shall not create or extend in any manner whatsoever, any liability of ST.

ST and the ST logo are trademarks or registered trademarks of ST in various countries.

Information in this document supersedes and replaces all information previously supplied.

The ST logo is a registered trademark of STMicroelectronics. All other names are the property of their respective owners.

© 2006 STMicroelectronics - All rights reserved

STMicroelectronics group of companies

Australia - Belgium - Brazil - Canada - China - Czech Republic - Finland - France - Germany - Hong Kong - India - Israel - Italy - Japan - Malaysia - Malta - Morocco - Singapore - Spain - Sweden - Switzerland - United Kingdom - United States of America

www.st.com



Looking for pricing, stock, or lifecycle information?

Click below to explore more details on WIN SOURCE:

- ⊖ [View STQ1NC45R-AP on WIN SOURCE](#)
- ⊖ [STMicroelectronics Information](#)

Optimize Your Supply Chain with WIN SOURCE Solutions

- ✓ Global Sourcing Solution
- ✓ Obsolete Management
- ✓ Cost Control Management
- ✓ Shortage Management
- ✓ Alternative Solution
- ✓ Excess Inventory Management