

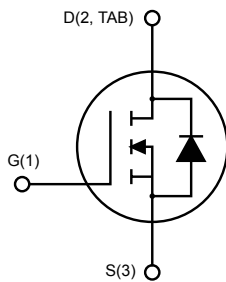

**THE DATASHEET OF
STW42N65M5**

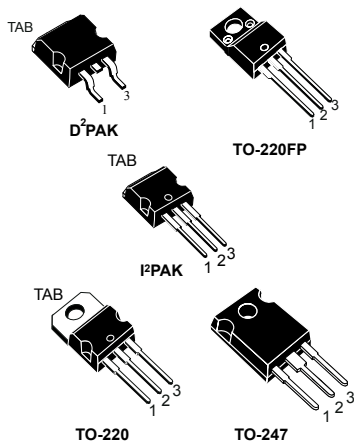

N-channel 650 V, 70 mΩ typ., 33 A, MDmesh M5 Power MOSFETs in D²PAK, TO-220FP, I²PAK, TO-220 and TO-247 packages



AM01475v1_noZen



Features

Order codes	V _{DS} @ T _{Jmax}	R _{DS(on)} max.	I _D	Package
STB42N65M5	710 V	79 mΩ	33 A	D ² PAK
STF42N65M5				TO-220FP
STI42N65M5				I ² PAK
STP42N65M5				TO-220
STW42N65M5				TO-247

- Extremely low R_{DS(on)}
- Low gate charge and input capacitance
- Excellent switching performance
- 100% avalanche tested

Applications

- Switching applications

Description

These devices are N-channel Power MOSFETs based on the MDmesh M5 innovative vertical process technology combined with the well-known PowerMESH horizontal layout. The resulting products offer extremely low on-resistance, making them particularly suitable for applications requiring high power and superior efficiency.

Product status

STB42N65M5
STF42N65M5
STI42N65M5
STP42N65M5
STW42N65M5

1 Electrical ratings

Table 1. Absolute maximum ratings

Symbol	Parameter	Value		Unit
		D ² PAK, I ² PAK, TO-220, TO-247	TO-220FP	
V _{GS}	Gate-source voltage	±25		V
I _D	Drain current (continuous) at T _C = 25 °C	33	33 ⁽¹⁾	A
	Drain current (continuous) at T _C = 100 °C	20.8	20.8 ⁽¹⁾	A
I _{DM} ⁽²⁾	Drain current (pulsed)	132	132	A
P _{TOT}	Total power dissipation at T _C = 25 °C	190	40	W
dv/dt ⁽³⁾	Peak diode recovery voltage slope	15		V/ns
V _{ISO}	Insulation withstand voltage (RMS) from all three leads to external heat sink (t = 1 s; T _C = 25 °C)	2500		V
T _J	Operating junction temperature range	-55 to 150		°C
T _{stg}	Storage temperature range			

- Limited by maximum junction temperature.
- Pulse width limited by safe operating area.
- I_{SD} ≤ 33 A, di/dt ≤ 400 A/μs, V_{DD} = 400 V, V_{DS(peak)} < V_{(BR)DSS}.

Table 2. Thermal data

Symbol	Parameter	Value					Unit
		D ² PAK	I ² PAK	TO-220	TO-247	TO-220FP	
R _{thj-case}	Thermal resistance junction-case	0.66			3.1	°C/W	
R _{thj-amb}	Thermal resistance junction-ambient		62.5	50	62.5	°C/W	
R _{thj-pcb} ⁽¹⁾	Thermal resistance junction-pcb	30				°C/W	

- When mounted on an 1 inch² FR-4, 2 Oz copper board.

Table 3. Avalanche characteristics

Symbol	Parameter	Value	Unit
I _{AR}	Avalanche current, repetitive or non-repetitive (pulse width limited by T _{Jmax})	11	A
E _{AS}	Single pulse avalanche energy (starting T _J = 25 °C, I _D = I _{AR} , V _{DD} = 50 V)	950	mJ

2 Electrical characteristics

($T_{CASE} = 25\text{ °C}$ unless otherwise specified)

Table 4. On/off states

Symbol	Parameter	Test conditions	Min.	Typ.	Max.	Unit
$V_{(BR)DSS}$	Drain-source breakdown voltage	$I_D = 1\text{ mA}$, $V_{GS} = 0\text{ V}$	650			V
I_{DSS}	Zero gate voltage drain current	$V_{GS} = 0\text{ V}$, $V_{DS} = 650\text{ V}$			1	μA
		$V_{GS} = 0\text{ V}$, $V_{DS} = 650\text{ V}$, $T_C = 125\text{ °C}$ ⁽¹⁾			100	μA
I_{GSS}	Gate body leakage current	$V_{GS} = \pm 25\text{ V}$, $V_{DS} = 0\text{ V}$			100	nA
$V_{GS(th)}$	Gate threshold voltage	$V_{DS} = V_{GS}$, $I_D = 250\text{ }\mu\text{A}$	3	4	5	V
$R_{DS(on)}$	Static drain-source on- resistance	$V_{GS} = 10\text{ V}$, $I_D = 16.5\text{ A}$		70	79	m Ω

1. Defined by design, not subject to production test.

Table 5. Dynamic

Symbol	Parameter	Test conditions	Min.	Typ.	Max.	Unit
C_{iss}	Input capacitance	$V_{DS} = 100\text{ V}$, $f = 1\text{ MHz}$, $V_{GS} = 0\text{ V}$	-	4650	-	pF
C_{oss}	Output capacitance			110		
C_{rss}	Reverse transfer capacitance			3.2		
$C_{o(tr)}$ ⁽¹⁾	Equivalent capacitance time related	$V_{DS} = 0\text{ to }520\text{ V}$, $V_{GS} = 0\text{ V}$	-	100	-	pF
$C_{o(er)}$ ⁽²⁾	Equivalent capacitance energy related			285		
R_g	Gate input resistance	$f = 1\text{ MHz}$, $I_D = 0\text{ A}$	-	1.1	-	Ω
Q_g	Total gate charge	$V_{DD} = 520\text{ V}$, $I_D = 33\text{ A}$,	-	98	-	nC
Q_{gs}	Gate-source charge	$V_{GS} = 0\text{ to }10\text{ V}$		28		
Q_{gd}	Gate-drain charge	(see Figure 20. Test circuit for gate charge behavior)		39		

1. $C_{o(tr)}$ is a constant capacitance value that gives the same charging time as C_{oss} while V_{DS} is rising from 0 to 80% V_{DSS} .

2. $C_{o(er)}$ is a constant capacitance value that gives the same stored energy as C_{oss} while V_{DS} is rising from 0 to 80% V_{DSS} .

Table 6. Switching times

Symbol	Parameter	Test conditions	Min.	Typ.	Max.	Unit
$t_{d(v)}$	Voltage delay time	$V_{DD} = 400\text{ V}$, $I_D = 20\text{ A}$, $R_G = 4.7\text{ }\Omega$, $V_{GS} = 10\text{ V}$	-	52	-	ns
$t_{r(v)}$	Voltage rise time			8.4		
$t_{f(i)}$	Current fall time	(see Figure 21. Test circuit for inductive load switching and diode recovery times and Figure 24. Switching time waveform)	-	8.7	-	ns
$t_{c(off)}$	Crossing time			14		

Table 7. Source-drain diode

Symbol	Parameter	Test conditions	Min.	Typ.	Max.	Unit
I_{SD}	Source-drain current		-		33	A
$I_{SDM}^{(1)}$	Source-drain current (pulsed)				132	
$V_{SD}^{(2)}$	Forward on voltage	$I_{SD} = 33 \text{ A}$, $V_{GS} = 0 \text{ V}$	-		1.5	V
t_{rr}	Reverse recovery time	$I_{SD} = 33 \text{ A}$, $di/dt = 100 \text{ A}/\mu\text{s}$	-	400		ns
Q_{rr}	Reverse recovery charge	$V_{DD} = 100 \text{ V}$		7		μC
I_{RRM}	Reverse recovery current	(see Figure 21. Test circuit for inductive load switching and diode recovery times)		35		A
t_{rr}	Reverse recovery time	$I_{SD} = 33 \text{ A}$, $di/dt = 100 \text{ A}/\mu\text{s}$	-	532		ns
Q_{rr}	Reverse recovery charge	$V_{DD} = 100 \text{ V}$, $T_j = 150 \text{ }^\circ\text{C}$		10		μC
I_{RRM}	Reverse recovery current	(see Figure 21. Test circuit for inductive load switching and diode recovery times)		38		A

1. Pulse width limited by safe operating area.
2. Pulsed: pulse duration = 300 μs , duty cycle 1.5%.

2.1 Electrical characteristics (curves)

Figure 1. Safe operating area for D²PAK, I²PAK, TO-220

Figure 2. Thermal impedance for D²PAK, I²PAK, TO-220

Figure 3. Safe operating area for TO-247

Figure 4. Thermal impedance for TO-247

Figure 5. Safe operating area for TO-220FP

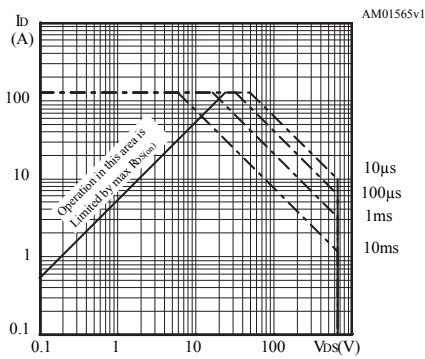
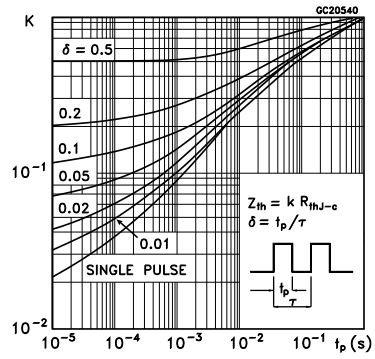
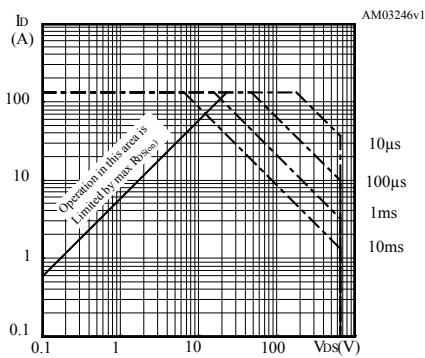
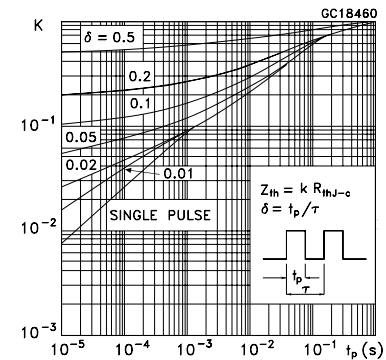
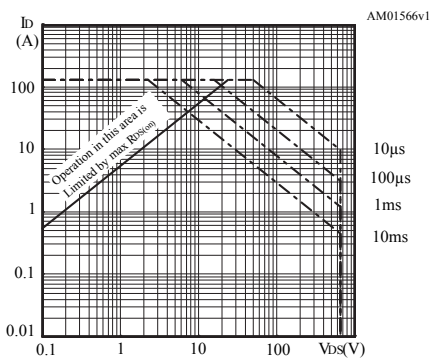
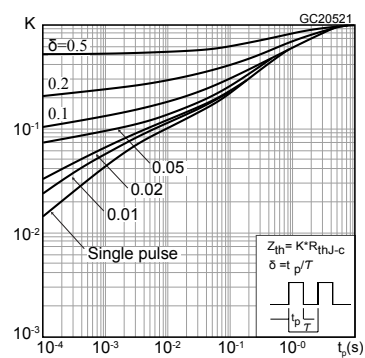
Figure 6. Thermal impedance for TO-220FP

Figure 7. Output characteristics

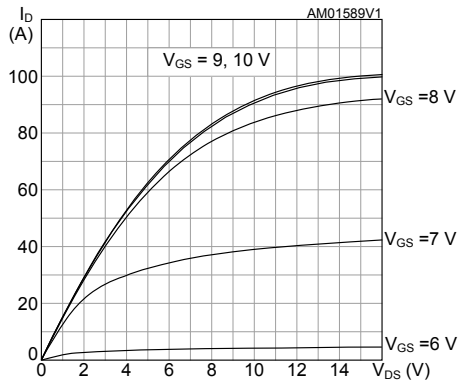

Figure 8. Transfer characteristics

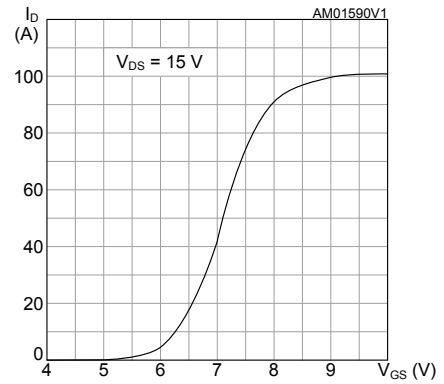

Figure 9. Gate charge vs gate-source voltage

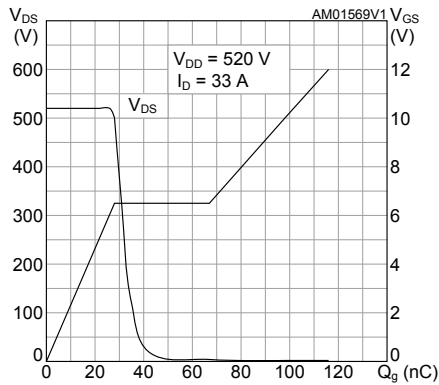

Figure 10. Static drain-source on-resistance

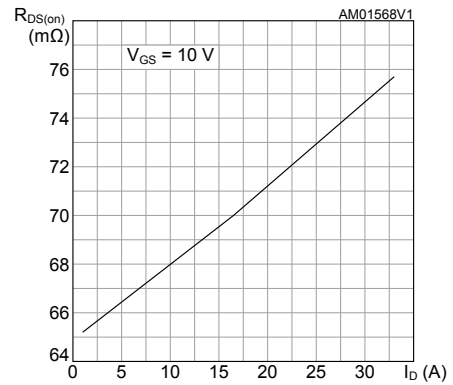

Figure 11. Capacitance variations

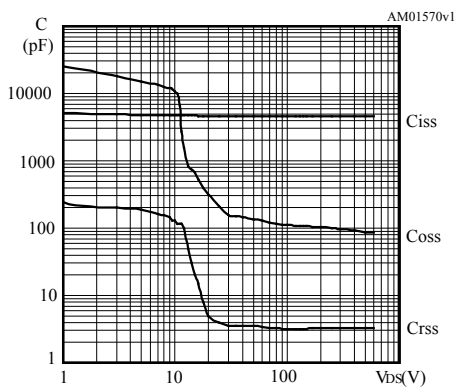

Figure 12. Output capacitance stored energy

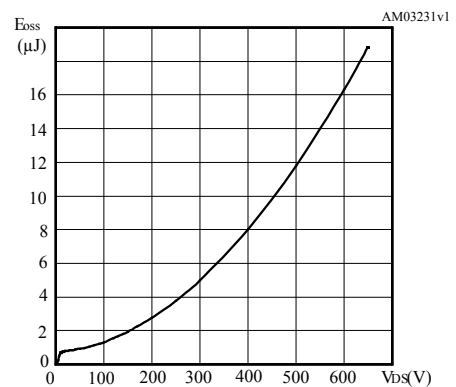
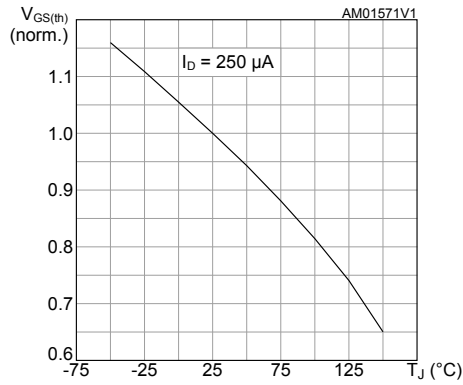
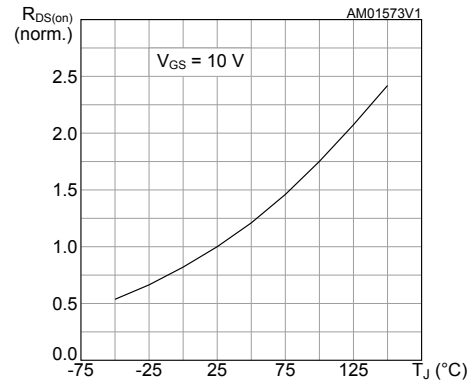
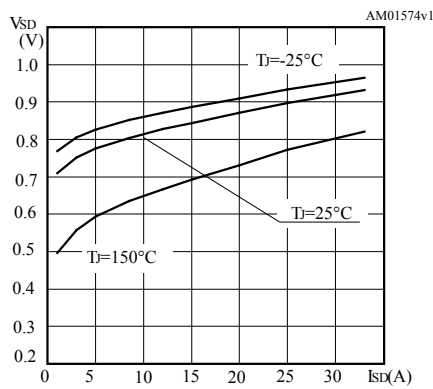
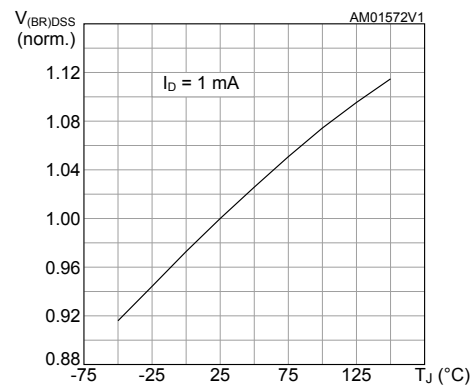
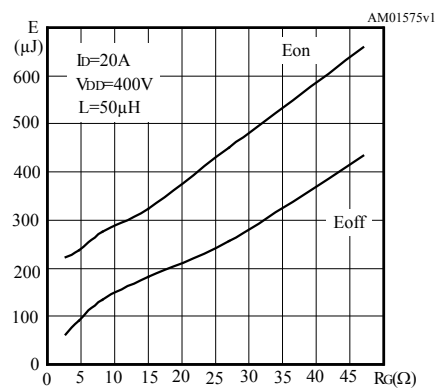
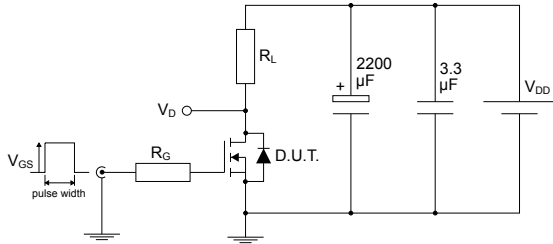

Figure 13. Normalized gate threshold voltage vs temperature

Figure 14. Normalized on-resistance vs temperature

Figure 15. Source-drain diode forward characteristics

Figure 16. Normalized $V_{(BR)DSS}$ vs temperature

Figure 17. Switching energy vs gate resistance

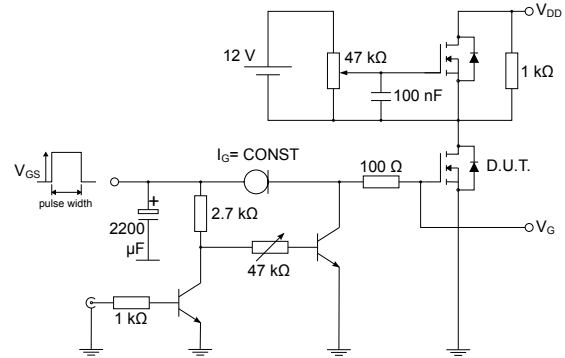
Note: E_{on} including reverse recovery of a SiC diode.

3 Test circuits

Figure 19. Test circuit for resistive load switching times

AM01468v1

Figure 20. Test circuit for gate charge behavior

AM01469v1

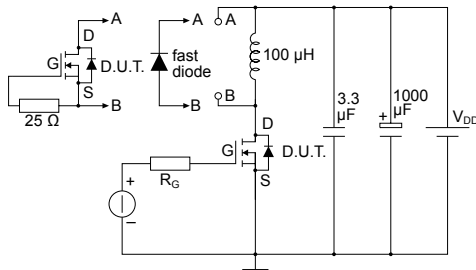
Figure 21. Test circuit for inductive load switching and diode recovery times

AM01470v1

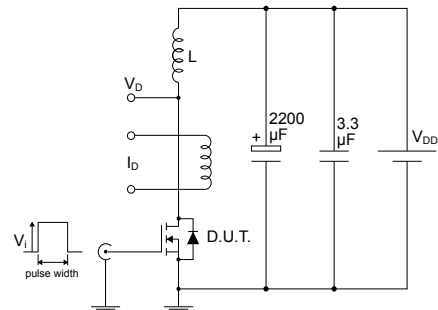
Figure 22. Unclamped inductive load test circuit

AM01471v1

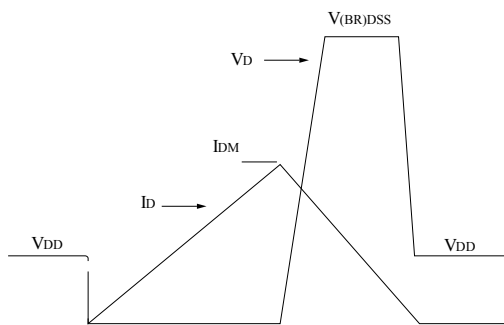
Figure 23. Unclamped inductive waveform

AM01472v1

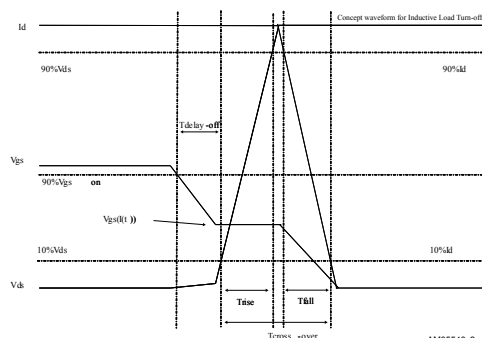
Figure 24. Switching time waveform

AM05540v2



4 Package information

In order to meet environmental requirements, ST offers these devices in different grades of **ECOPACK** packages, depending on their level of environmental compliance. ECOPACK specifications, grade definitions and product status are available at: www.st.com. ECOPACK is an ST trademark.

4.1 D²PAK (TO-263) type A2 package information

Figure 25. D²PAK (TO-263) type A2 package outline

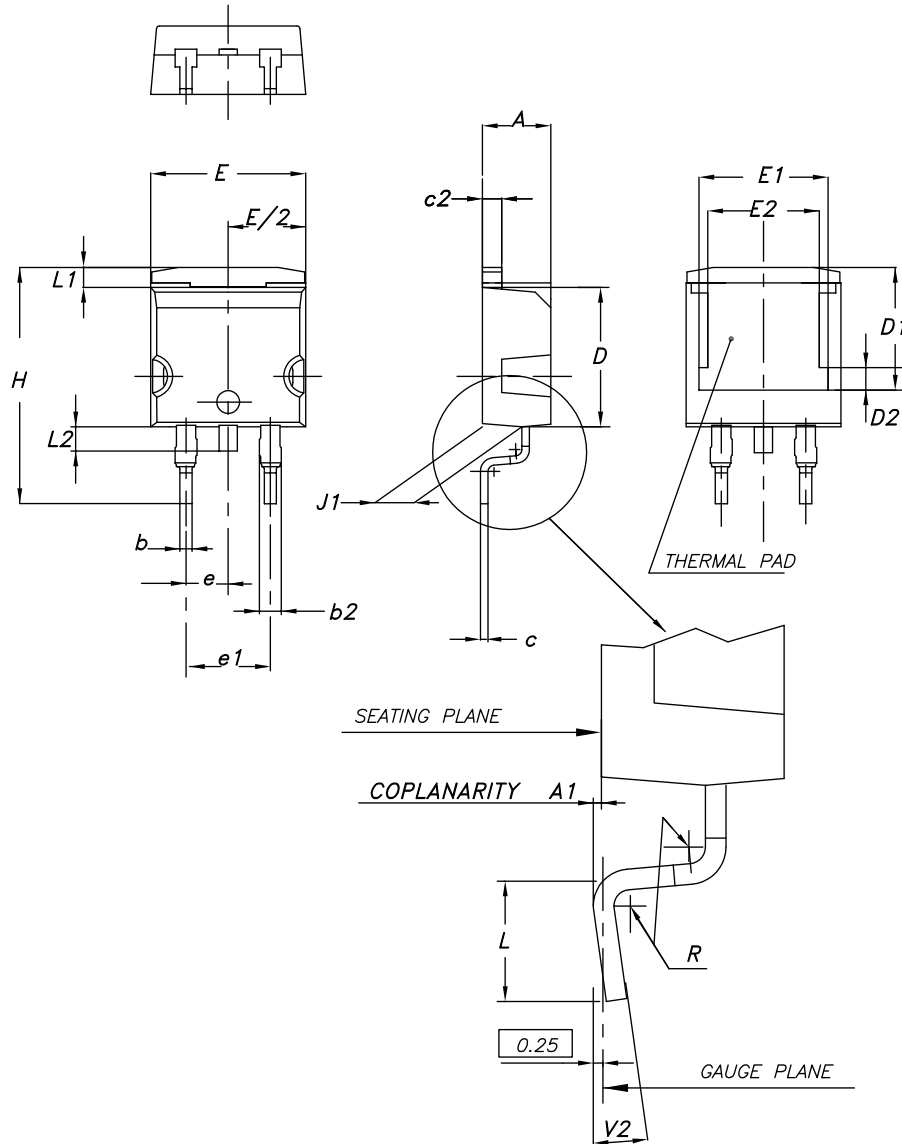

0079457_A2_26

Table 8. D²PAK (TO-263) type A2 package mechanical data

Dim.	mm		
	Min.	Typ.	Max.
A	4.40		4.60
A1	0.03		0.23
b	0.70		0.93
b2	1.14		1.70
c	0.45		0.60
c2	1.23		1.36
D	8.95		9.35
D1	7.50	7.75	8.00
D2	1.10	1.30	1.50
E	10.00		10.40
E1	8.70	8.90	9.10
E2	7.30	7.50	7.70
e		2.54	
e1	4.88		5.28
H	15.00		15.85
J1	2.49		2.69
L	2.29		2.79
L1	1.27		1.40
L2	1.30		1.75
R		0.40	
V2	0°		8°

Figure 26. D²PAK (TO-263) recommended footprint (dimensions are in mm)

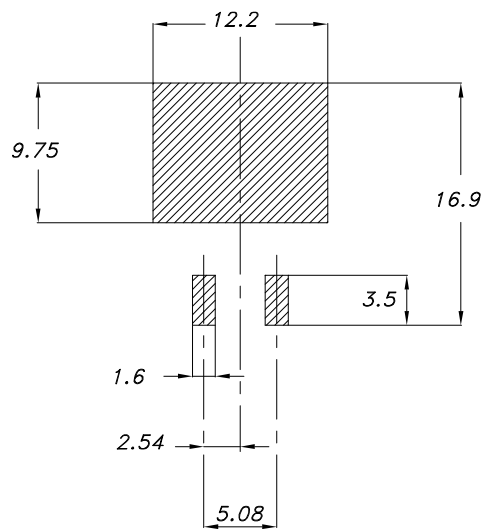

Footprint

4.2 D²PAK packing information

Figure 27. D²PAK tape outline

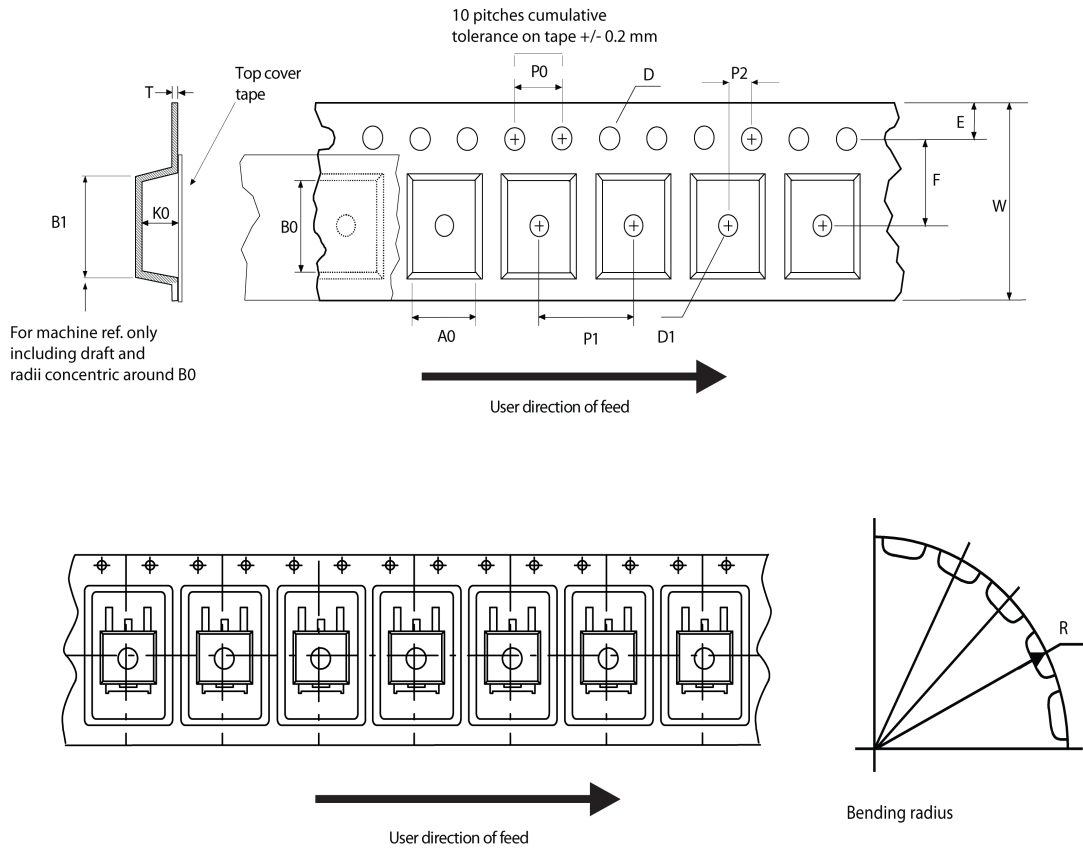

AM08852v1

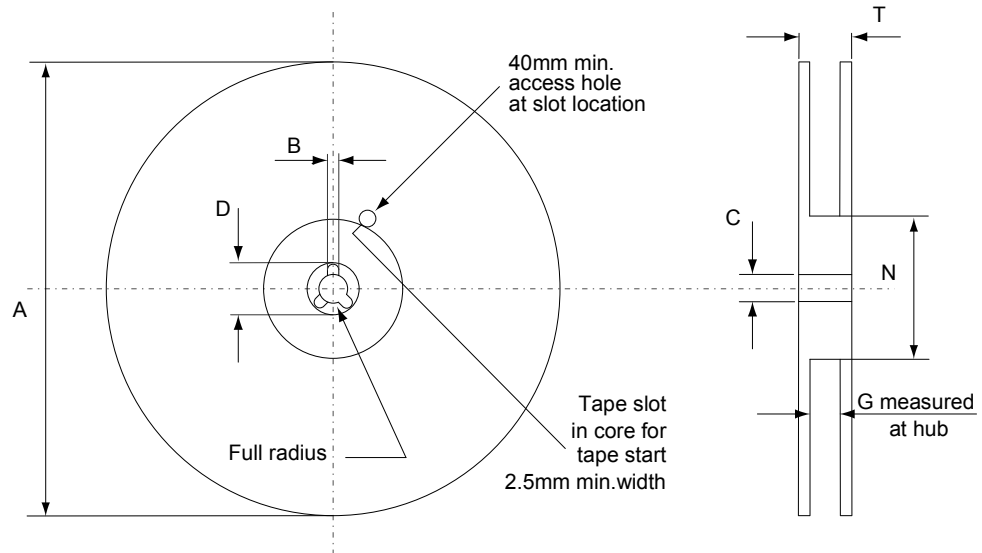
Figure 28. D²PAK reel outline

AM06038v1

Table 9. D²PAK tape and reel mechanical data

Tape			Reel			
Dim.	mm		Dim.	mm		
	Min.	Max.		Min.	Max.	
A0	10.5	10.7	A		330	
B0	15.7	15.9	B	1.5		
D	1.5	1.6	C	12.8	13.2	
D1	1.59	1.61	D	20.2		
E	1.65	1.85	G	24.4	26.4	
F	11.4	11.6	N	100		
K0	4.8	5.0	T		30.4	
P0	3.9	4.1	Base quantity Bulk quantity			
P1	11.9	12.1				1000
P2	1.9	2.1				1000
R	50					
T	0.25	0.35				
W	23.7	24.3				

4.3 TO-220FP package information

Figure 29. TO-220FP package outline

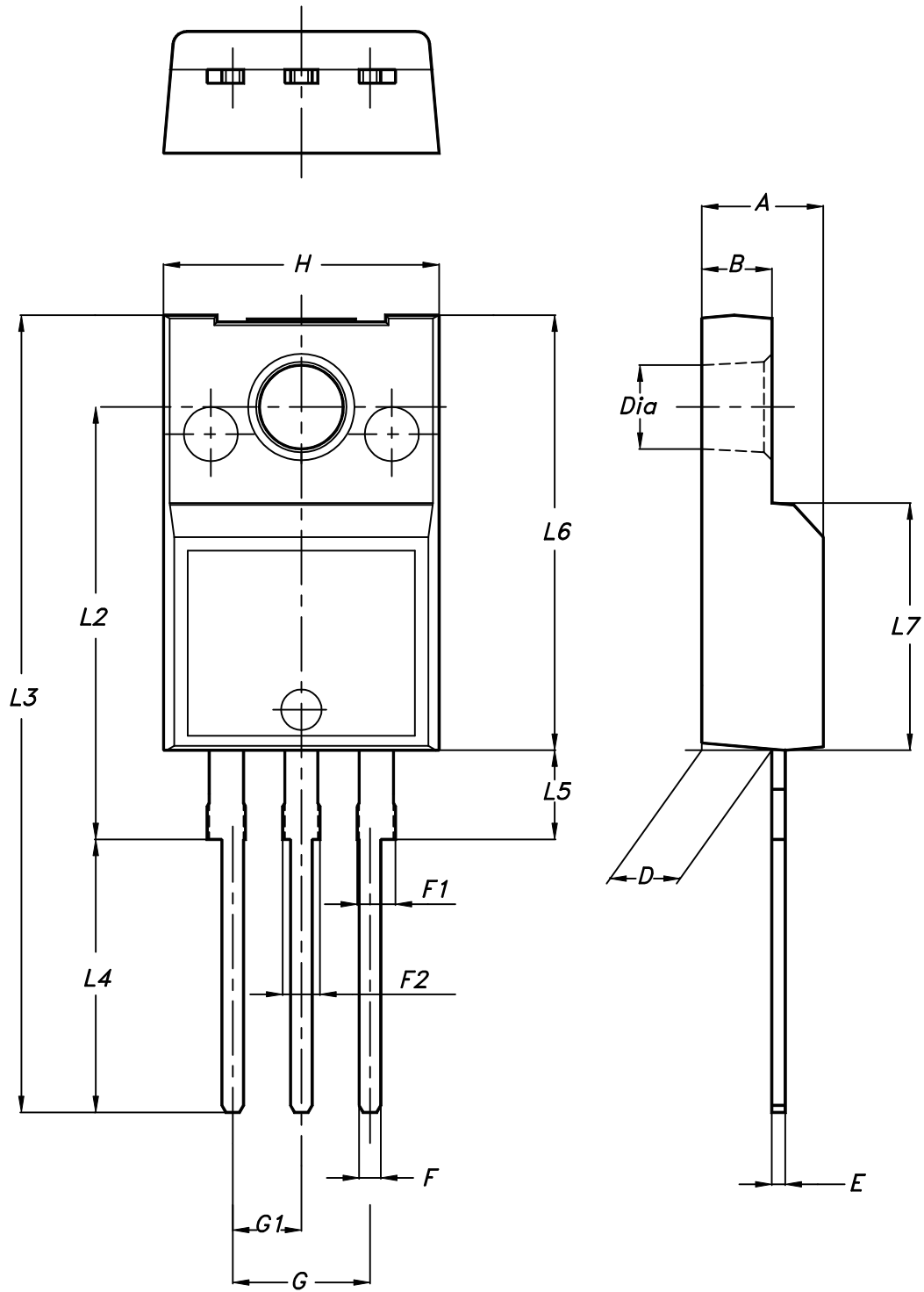

7012510_Rev_12_B

Table 10. TO-220FP package mechanical data

Dim.	mm		
	Min.	Typ.	Max.
A	4.4		4.6
B	2.5		2.7
D	2.5		2.75
E	0.45		0.7
F	0.75		1
F1	1.15		1.70
F2	1.15		1.70
G	4.95		5.2
G1	2.4		2.7
H	10		10.4
L2		16	
L3	28.6		30.6
L4	9.8		10.6
L5	2.9		3.6
L6	15.9		16.4
L7	9		9.3
Dia	3		3.2

4.4 I²PAK package information

Figure 30. I²PAK package outline

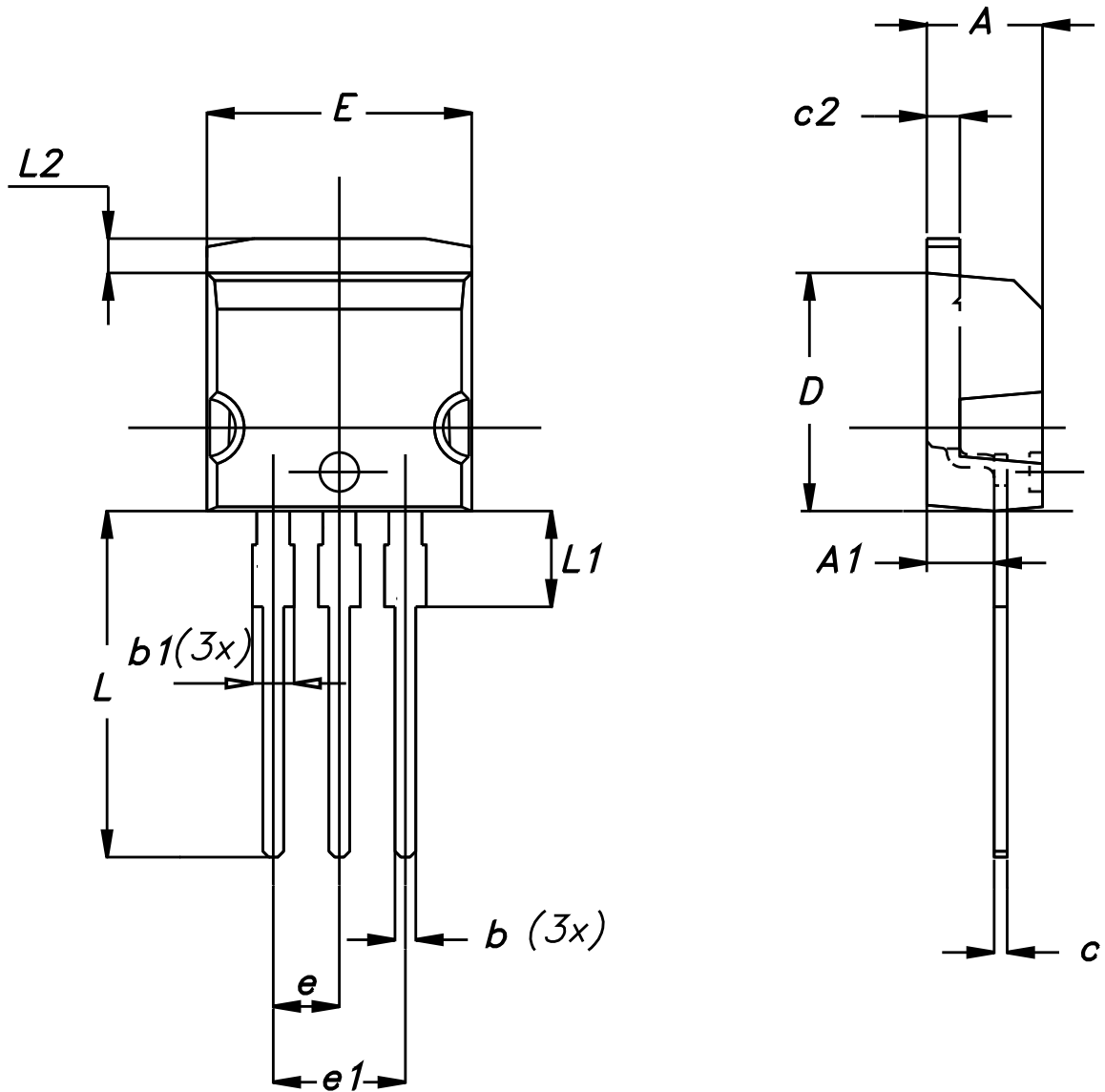

0004982_Rev_H

Table 11. I²PAK package mechanical data

Dim.	mm		
	Min.	Typ.	Max.
A	4.40	-	4.60
A1	2.40	-	2.72
b	0.61	-	0.88
b1	1.14	-	1.70
c	0.49	-	0.70
c2	1.23	-	1.32
D	8.95	-	9.35
e	2.40	-	2.70
e1	4.95	-	5.15
E	10	-	10.40
L	13	-	14
L1	3.50	-	3.93
L2	1.27	-	1.40

4.5 TO-220 type A package information

Figure 31. TO-220 type A package outline

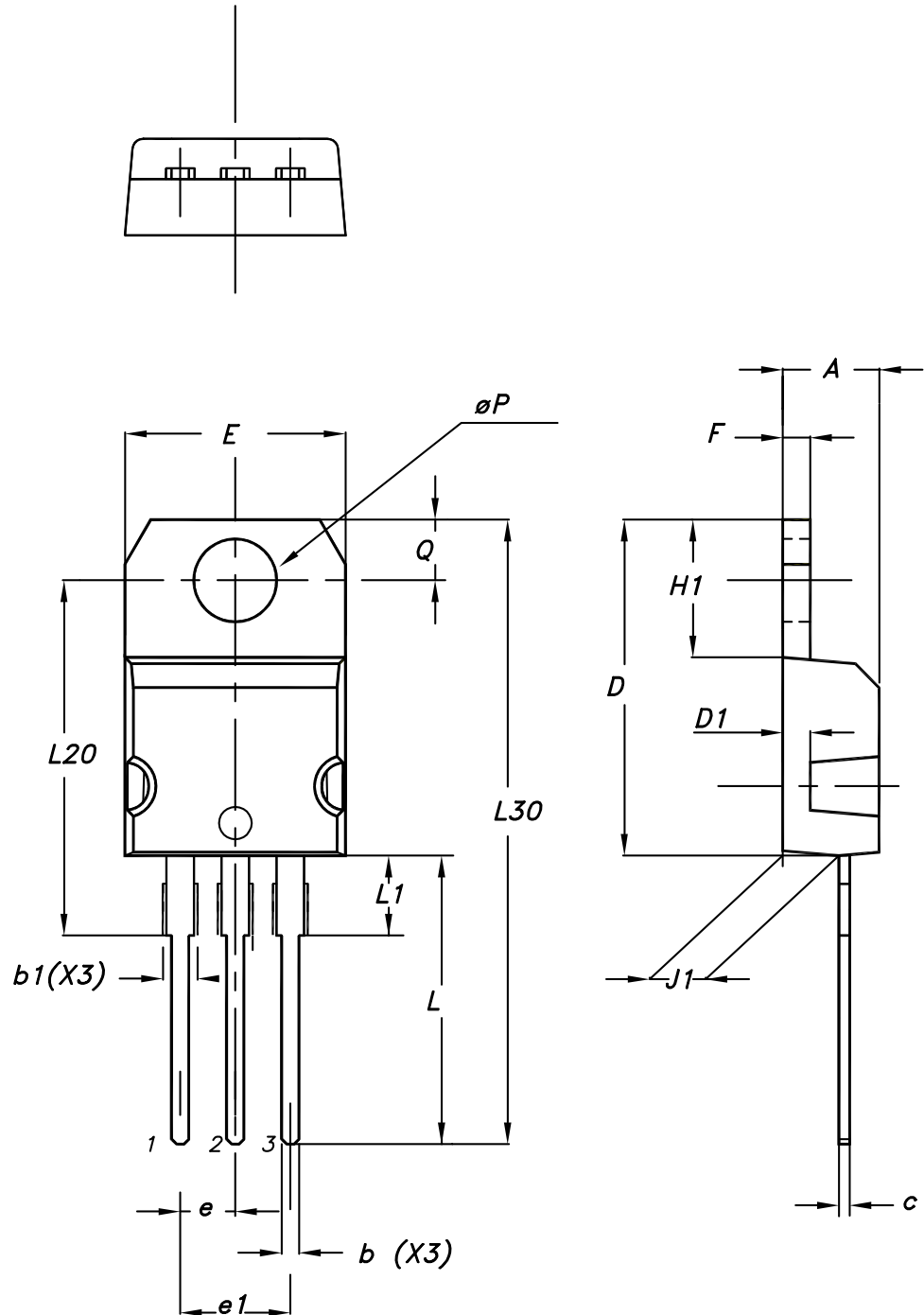

0015988_typeA_Rev_22

Table 12. TO-220 type A package mechanical data

Dim.	mm		
	Min.	Typ.	Max.
A	4.40		4.60
b	0.61		0.88
b1	1.14		1.55
c	0.48		0.70
D	15.25		15.75
D1		1.27	
E	10.00		10.40
e	2.40		2.70
e1	4.95		5.15
F	1.23		1.32
H1	6.20		6.60
J1	2.40		2.72
L	13.00		14.00
L1	3.50		3.93
L20		16.40	
L30		28.90	
øP	3.75		3.85
Q	2.65		2.95

4.6 TO-247 package information

Figure 32. TO-247 package outline

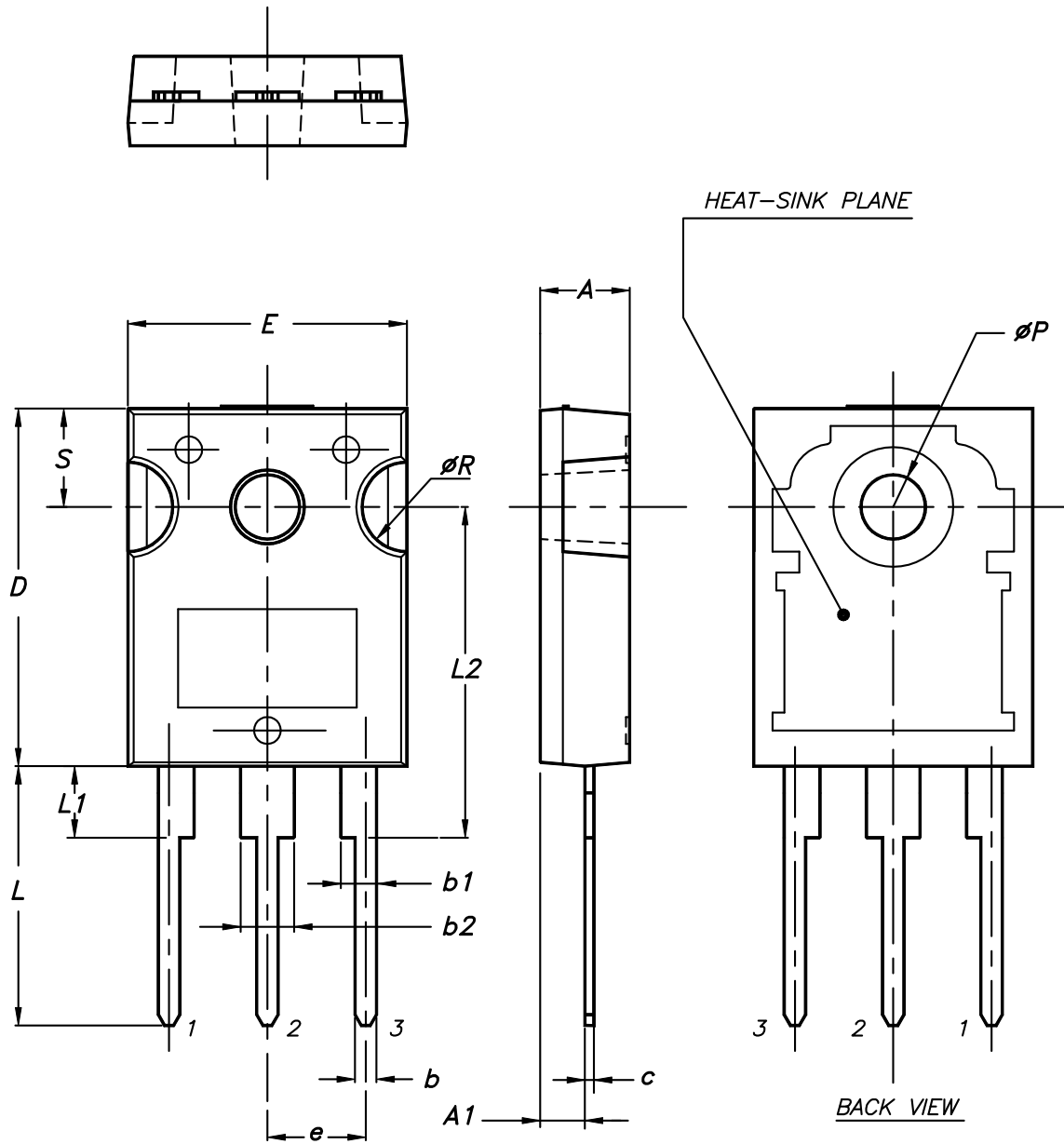

0075325_9

Table 13. TO-247 package mechanical data

Dim.	mm		
	Min.	Typ.	Max.
A	4.85		5.15
A1	2.20		2.60
b	1.0		1.40
b1	2.0		2.40
b2	3.0		3.40
c	0.40		0.80
D	19.85		20.15
E	15.45		15.75
e	5.30	5.45	5.60
L	14.20		14.80
L1	3.70		4.30
L2		18.50	
ØP	3.55		3.65
ØR	4.50		5.50
S	5.30	5.50	5.70

5 Ordering information

Table 14. Order codes

Order code	Marking	Package	Packing
STB42N65M5	42N65M5	D ² PAK	Tape and reel
STF42N65M5		TO-220FP	Tube
STI42N65M5		I ² PAK	
STP42N65M5		TO-220	
STW42N65M5		TO-247	

Revision history

Table 15. Document revision history

Date	Version	Changes
16-Jan-2009	1	First release.
15-May-2009	2	Updated <i>figures 9, 10, 11</i> and <i>17</i>
12-Jun-2009	3	<i>Figure 15</i> has been updated
02-May-2019	4	Modified features and description on cover page. Updated Section 4 Package information . Minor text changes.

Contents

1	Electrical ratings	2
2	Electrical characteristics	3
2.1	Electrical characteristics (curves)	5
3	Test circuits	8
4	Package information	9
4.1	D ² PAK (TO-263) type A2 package information	9
4.2	D ² PAK packing information	11
4.3	TO-220FP package information	13
4.4	I ² PAK package information	15
4.5	TO-220 type A package information	17
4.6	TO-247 package information	19
5	Ordering information	22
	Revision history	23



IMPORTANT NOTICE – PLEASE READ CAREFULLY

STMicroelectronics NV and its subsidiaries (“ST”) reserve the right to make changes, corrections, enhancements, modifications, and improvements to ST products and/or to this document at any time without notice. Purchasers should obtain the latest relevant information on ST products before placing orders. ST products are sold pursuant to ST’s terms and conditions of sale in place at the time of order acknowledgement.

Purchasers are solely responsible for the choice, selection, and use of ST products and ST assumes no liability for application assistance or the design of Purchasers’ products.

No license, express or implied, to any intellectual property right is granted by ST herein.

Resale of ST products with provisions different from the information set forth herein shall void any warranty granted by ST for such product.

ST and the ST logo are trademarks of ST. For additional information about ST trademarks, please refer to www.st.com/trademarks. All other product or service names are the property of their respective owners.

Information in this document supersedes and replaces information previously supplied in any prior versions of this document.





© 2019 STMicroelectronics – All rights reserved

Looking for pricing, stock, or lifecycle information?

Click below to explore more details on WIN SOURCE:

-  [View STW42N65M5 on WIN SOURCE](#)
-  [STMicroelectronics Information](#)

Optimize Your Supply Chain with WIN SOURCE Solutions

-  Global Sourcing Solution
-  Obsolete Management
-  Cost Control Management
-  Shortage Management
-  Alternative Solution
-  Excess Inventory Management