

TB6066FNG

Shock Sensor IC

TB6066FNG detects an existence of external shock through the shock sensor and output Low-level signal at 7 pin.

It has so excellent characteristic in S/N ratio that user can use Analog signal for mechanical control systems, like servo control.

Features

- TB6066FNG operates from 2.7 to 5.5 V DC single power supply voltage.
- Signal from the shock sensor is amplified according to setting gain, and is detected through the internal window comparator.
- Input terminal of sensor signal is designed high impedance. Differential input impedance = 100 M Ω (typ.)
- Three Operational Amplifier is built in for design flexibility. (*Note 1)
- Sensitivity of shock detection can be adjusted by external devices.
- Small package: SSOP16-P-225-0.65B (0.65 mm pitch)
- Excellent S/N ratio: Improved 10dB compared with our TA6038FN/FNG

*Note 1: LPF (low pass filter) circuitry is not built in. User needs to make some filter with one operational amplifier to cancel the signal of resonant frequency of piezo sensor

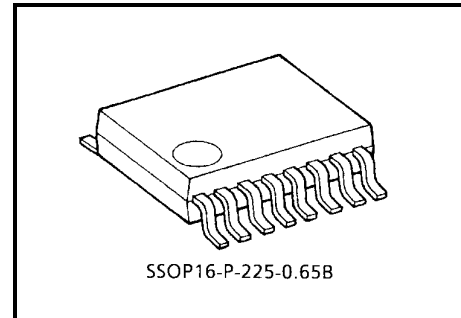

Weight: 0.07 g (typ.)

Block Diagram

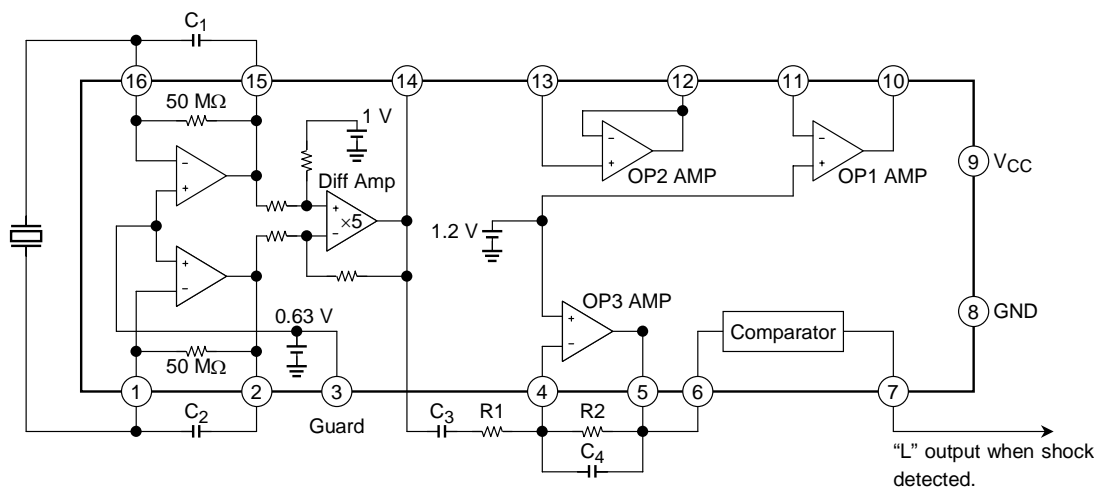

Pin Function

Pin No.	Pin Name	Function
1	SIA	Connection terminal of shock sensor
2	SOA	Amp (A) output terminal
3	VR	Guard terminal. Reference voltage to protect (1, 16 pin)
4	A3I	OP-AMP (3) input terminal
5	A3O	OP-AMP (3) output terminal
6	CMI	Comparator Input terminal
7	CMO	Comparator Output terminal (output = "L" when shock is detected.)
8	GND	Ground terminal
9	V _{CC}	Power supply voltage
10	A1O	OP-AMP (1) output terminal
11	A1I	OP-AMP (1) input terminal
12	A2O	OP-AMP (2) output terminal
13	A2I	OP-AMP (2) input terminal
14	DO	Differential-Amp output terminal
15	SOB	Amp (B) output terminal
16	SIB	Connection terminal of shock sensor

Pin Connection (top view)

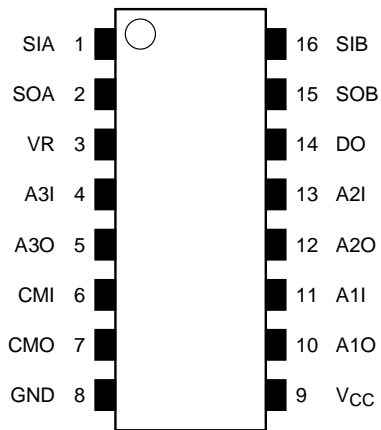

Maximum Ratings (Ta = 25°C)

Characteristics	Symbol	Rating	Unit
Power supply voltage	V _{CC}	6	V
Input voltage	V _{IN}	-0.3 to V _{CC} + 0.3	V
Power dissipation	P _D	300	mW
Storage temperature	T _{stg}	-55 to 150	°C

Recommend Operating Condition

Characteristics	Symbol	Rating	Unit
Power supply voltage	V _{CC}	2.7 to 5.5	V
Operating temperature	T _{opr}	-25 to 85	°C

Note: The IC may be destroyed due to short circuit between adjacent pins, incorrect orientation of device's mounting, connecting positive and negative power supply pins wrong way round, air contamination fault, or fault by improper grounding.

Electrical Characteristics (1) --- Guaranteed data (unless otherwise specified, $V_{CC} = 3.3\text{ V}$, $T_a = 25^\circ\text{C}$)

Characteristics	Symbol	Test Circuit	Test Condition	Min	Typ.	Max	Unit
Supply voltage	V_{CC}	—	—	2.7	3.3	5.5	V
Supply current	I_{CC}	1	$V_{CC} = 3.3\text{ V}$	—	3.5	5	mA
			$V_{CC} = 5.0\text{ V}$	—	3.6	5	

(DIFF-AMP)

Characteristics	Symbol	Test Circuit	Test Condition	Min	Typ.	Max	Unit
Gain	G_{VBuf}	2	—	13.6	14	14.4	dB
Output DC voltage	V_{oBuf}	3	Connect C = 1000 pF between 1 pin and 2 pin, 15 pin and 16 pin,	0.7	1	1.3	V
Output source current	$I_{B_{SO}}$	4	$V_{oh} = V_{CC} - 1\text{ V}$	0.6	1.9	—	mA
Output sink current	$I_{B_{Si}}$	5	$V_{ol} = 0.3\text{ V}$	70	150	—	μA

(OP-AMP1)

Characteristics	Symbol	Test Circuit	Test Condition	Min	Typ.	Max	Unit
Input voltage 1	V_{in1}	6	—	1.135	1.2	1.265	V
Input current	I_{in}	7	—	—	40	100	nA
Output voltage range (Low side)	V_{ol}	—	—	0.3	—	—	V
Output voltage range (High side)	V_{oh}	—	—	—	—	$V_{CC} - 1$	V
Output source current	$I_{A_{SO}}$	8	$V_{oh} = V_{CC} - 1\text{ V}$	200	800	—	μA
Output sink current	$I_{A_{Si}}$	9	$V_{ol} = 0.3\text{ V}$	100	200	—	μA

(OP-AMP2)

Characteristics	Symbol	Test Circuit	Test Condition	Min	Typ.	Max	Unit
Input voltage range (Low side)	V_{il}	—	—	0	—	—	V
Input voltage range (High side)	V_{ih}	—	—	—	—	$V_{CC} - 1$	V
Input current	I_{in}	10	Input voltage 1.0 V	-100	—	100	nA
Output voltage range (Low side)	V_{ol}	—	—	0.3	—	—	V
Output voltage range (High side)	V_{oh}	—	—	—	—	$V_{CC} - 1$	V
Output source current	$I_{A_{SO}}$	11	$V_{oh} = V_{CC} - 1\text{ V}$	200	800	—	μA
Output sink current	$I_{A_{Si}}$	12	$V_{ol} = 0.3\text{ V}$	100	200	—	μA

(OP-AMP3)

Characteristics	Symbol	Test Circuit	Test Condition	Min	Typ.	Max	Unit
Input voltage 1	V _{in1}	13	—	1.135	1.2	1.265	V
Input current	I _{in}	14	—	—	40	100	nA
Output voltage range (Low side)	V _{ol}	—	—	0.3	—	—	V
Output voltage range (High side)	V _{oh}	—	—	—	—	V _{CC} - 1	V
Output source current	I _{Aso}	15	V _{oh} = V _{CC} - 1 V	200	800	—	μA
Output sink current	I _{Asi}	16	V _{ol} = 0.3 V	100	200	—	μA

(Window-Comparator)

Characteristics	Symbol	Test Circuit	Test Condition	Min	Typ.	Max	Unit
Output pull-up resistance	R _{W_u}	17	—	21	27	33	kΩ
Output sink current	I _{W_{si}}	18	V _{ol} = 0.3 V	1.0	3.0	—	mA

(Guard Terminal)

Characteristics	Symbol	Test Circuit	Test Condition	Min	Typ.	Max	Unit
Reference Voltage	V _{ref}	—	—	0.50	0.63	0.80	V

Note: This terminal should be used to make guard ring for (1, 16 pin). Please don't use for any other usage.

Electrical Characteristics (2) --- Reference data for application (Note)

(DIFF-AMP)

Characteristics	Symbol	Test Circuit	Test Condition	Min	Typ.	Max	Unit
Input impedance	Zin	—	—	30	100	—	MΩ

(OP-AMP1/2/3)

Characteristics	Symbol	Test Circuit	Test Condition	Min	Typ.	Max	Unit
Cut-off frequency	fT	—	—	500	—	—	kHz
Openloop gain	Gvo	—	—	80	90	—	dB
Offset voltage (OP-AMP1/3)	Voff	—	—	-5	0	5	mV
Offset voltage (OP-AMP2)	Voff	—	—	-15	0	15	mV

(Window-Comparator)

Characteristics	Symbol	Test Circuit	Test Condition	Min	Typ.	Max	Unit
Trip voltage 1	Vtrp1	—	—	Vin1 ±0.37	Vin1 ±0.4	Vin1 ±0.43	V

Note: Toshiba can not test these tables of characteristics for all samples. Therefore Toshiba does not guarantee the data. Please use the data as reference data for customer's application.

Application Note

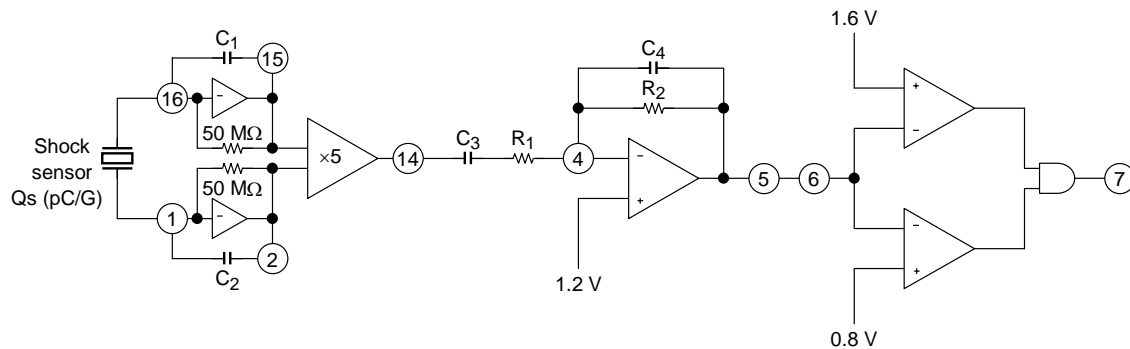

Figure 1 The Configuration of G-Force Sensor Amplifier

Figure 1 shows the configuration of G-Force sensor amplifier.
The shock sensor is connected between the pins 1 and 16.

< How to output 0 or 1 from the pin 7 to detect whether there is a shock or not. >
– Using a sensor with the sensitivity Q_s (pC/G) to detect the shock g (G). –

a. Setting gain: $C_1 = C_2$ (pF), R_1 (kΩ), R_2 (kΩ)

$$\frac{Q_s \times g}{C_1} \times 2 \times 5 \times \frac{R_2}{R_1} = 0.4 \text{ (V)}$$

$$C_1 = C_2 = \frac{Q_s \times g}{0.04} \times \frac{R_2}{R_1}$$

Example: Detecting 5 (G)-shock using a sensor with $Q_s = 0.34$ (pC/G), $R_1 = 10$ (kΩ), $R_2 = 100$ (kΩ).

$$C_1 = C_2 = \frac{0.34 \times 5}{0.04} \times \frac{100}{10} = 425 \text{ (pF)}$$

b. Setting the frequency (Hz) of HPF: Setting C_3 (μF), R_1 (kΩ)

$$f_c \text{ (Hz)} = \frac{1}{2 \times \pi \times R_1 \times C_3} \times 10^3$$

Example: Setting the frequency to 20 Hz with $R_1 = 10$ (kΩ).

$$C_3 = \frac{1}{2 \times \pi \times 10 \times 20} \times 10^3 = 0.8 \text{ (μF)}$$

c. Setting the frequency (kHz) of LPF: Setting C_4 (pF), R_2 (kΩ)

$$f_c \text{ (kHz)} = \frac{1}{2 \times \pi \times R_2 \times C_4} \times 10^6$$

Example: Setting the frequency to 5 kHz with $R_2 = 100$ (kΩ).

$$C_4 = \frac{1}{2 \times \pi \times 100 \times 5} \times 10^6 = 318 \text{ (pF)}$$

< How to output the voltage according to the shock through the pin 5. >

– Using a sensor with the sensitivity Q_s (pC/G), and assuming the shock sensitivity of the system is V_{system} (mV/G). –

a. Setting gain: $C_1 = C_2$ (pF), R_1 (kΩ), R_2 (kΩ)

$$\frac{Q_s}{C_1} \times 2 \times 5 \times \frac{R_2}{R_1} = V_{\text{system}} \times 10^3 \text{ (mV/G)}$$

Example: Designing the system with 200 (mV/G) by using a sensor that $Q_s = 0.34$ (pC/G), $R_1 = 10$ (kΩ), $R_2 = 100$ (kΩ).

$$C_1 = C_2 = \frac{Q_s}{V_{\text{system}}} \times \frac{R_2}{R_1} \times 10^4 \text{ (pF)}$$

$$C_1 = C_2 = \frac{0.34}{200} \times \frac{100}{10} \times 10^4 = 170 \text{ (pF)}$$

Equivalent Circuit

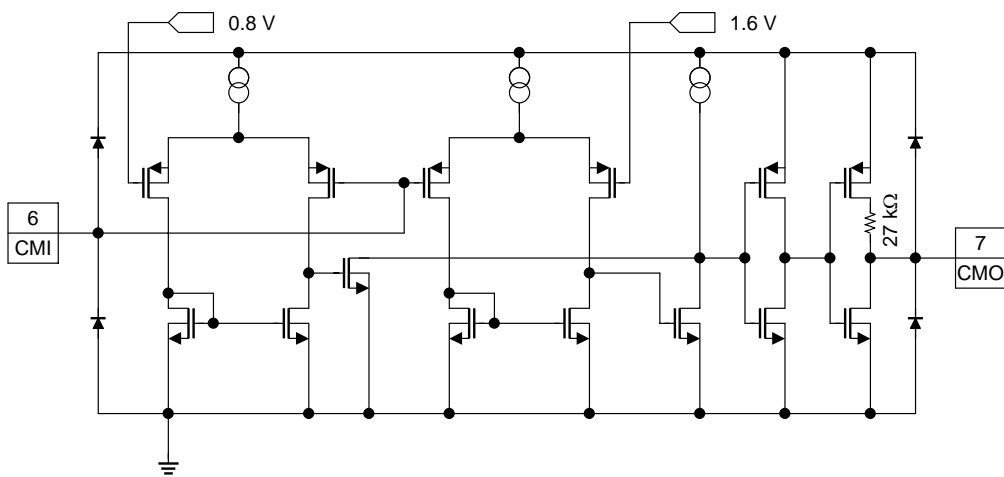
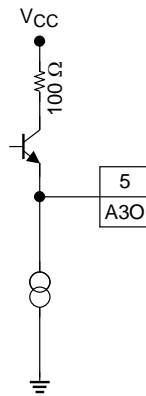
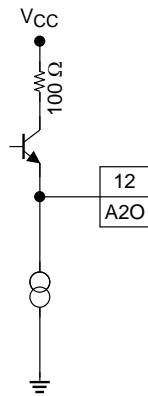
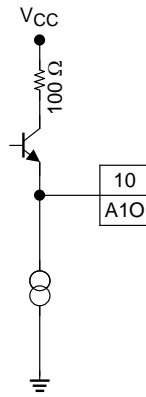
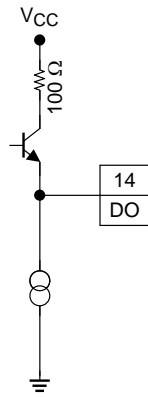

Test Circuit

(1) Supply current: **ICC**

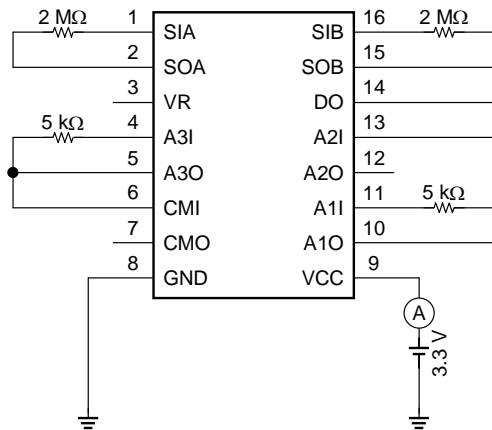

(2) DIFF-AMP

Gain: **GvBuf**

Step 1

$$\text{Gain} = (M2 \cdot M1) / (0.63 - 0.47)$$

Step 2

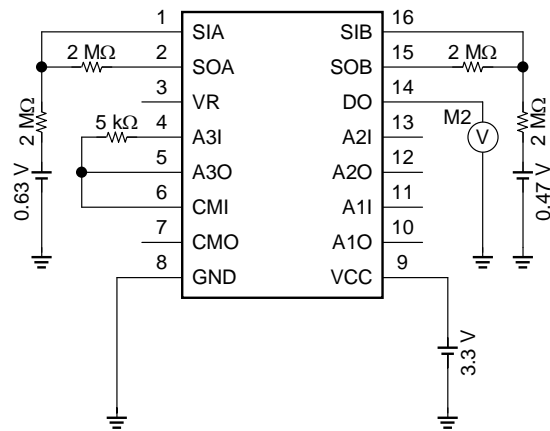
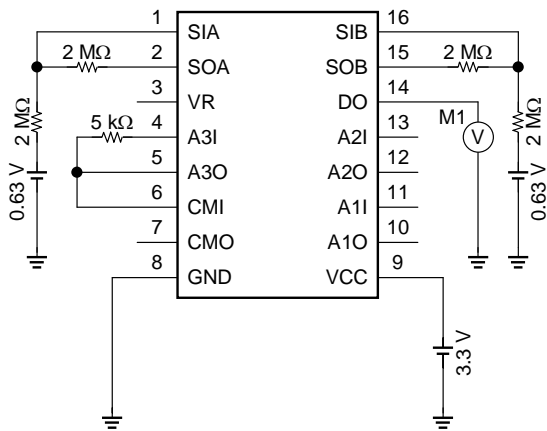

(3) DIFF-AMP

Output DC voltage: **VoBuf**

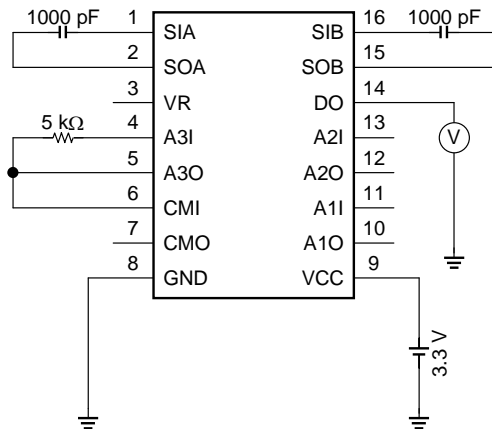

(4) DIFF-AMP
Output source current: **IBso**

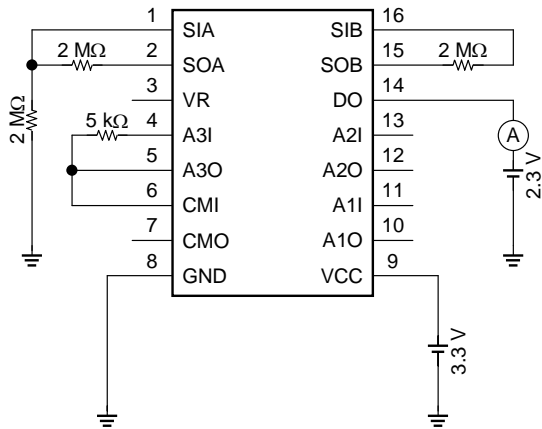

(5) DIFF-AMP
Output sink current: **IBsi**

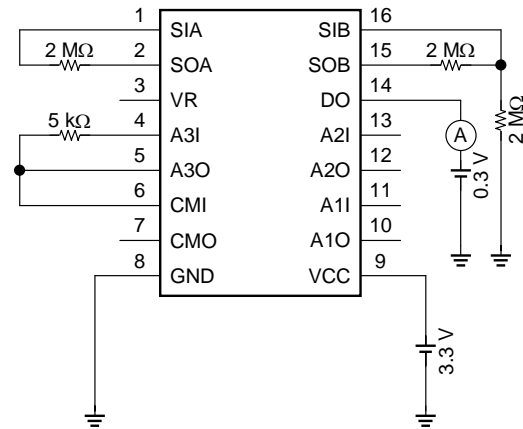

(6) OP-AMP1
Input voltage 1: **Vin1**

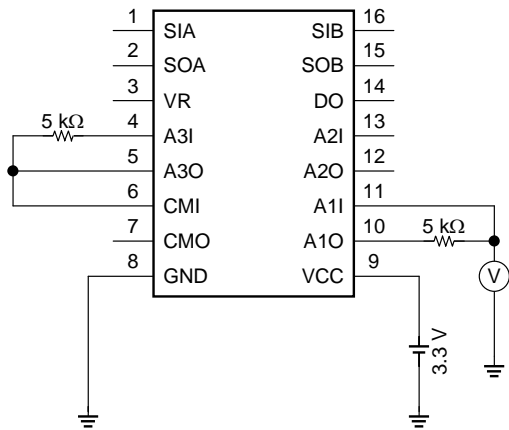

(7) OP-AMP1
Input current: **Iin**

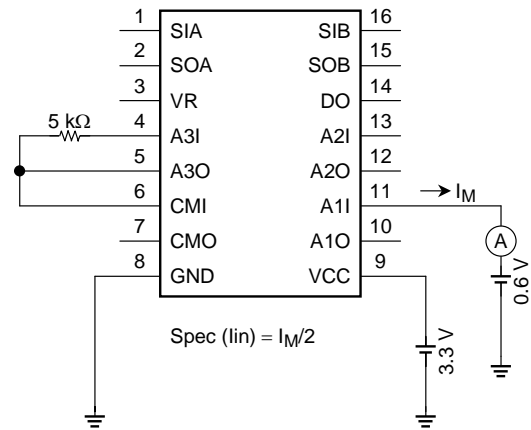

(8) OP-AMP1
Output source current: **IAso**

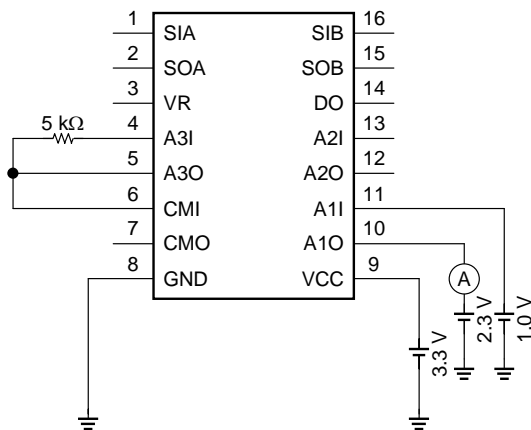

(9) OP-AMP1
Output sink current: **IAsi**

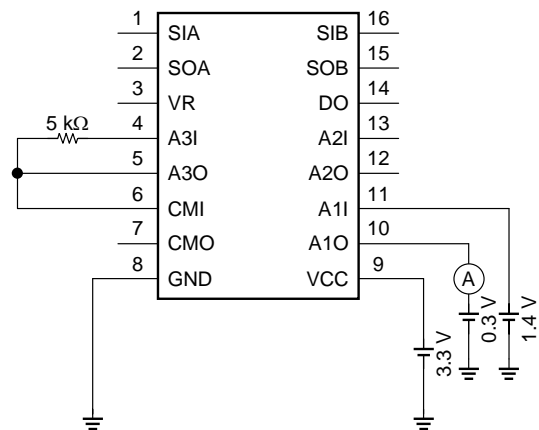

(10) OP-AMP2

Input current: I_{in}

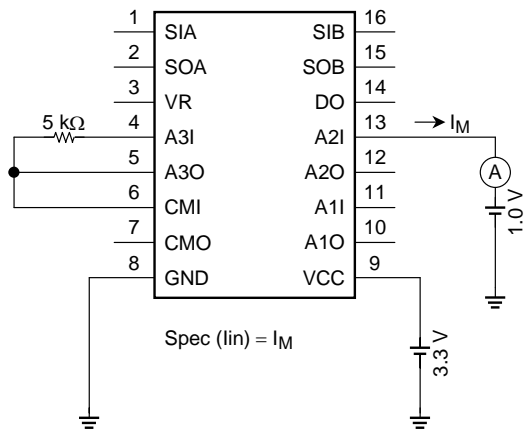

(11) OP-AMP2

Output source current: I_{Aso}

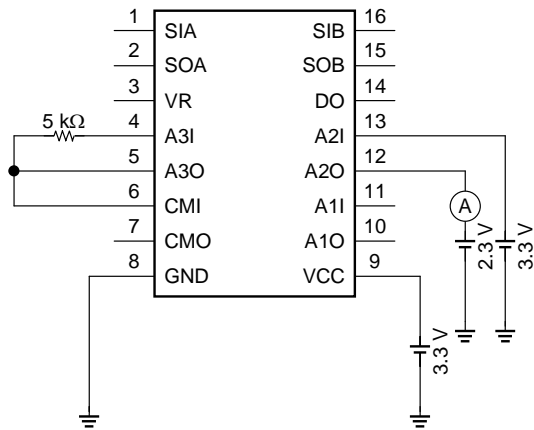

(12) OP-AMP2

Output sink current: I_{Asi}

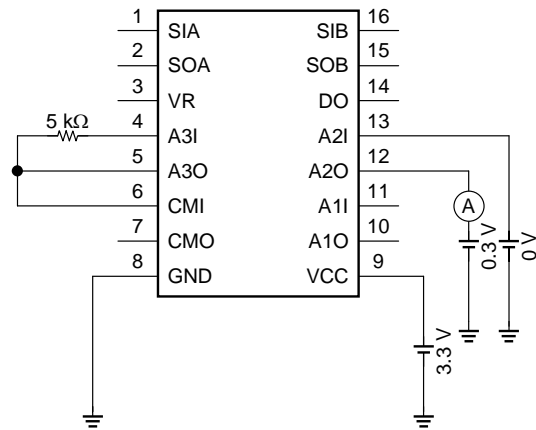

(13) OP-AMP3

Input voltage 1: V_{in1}

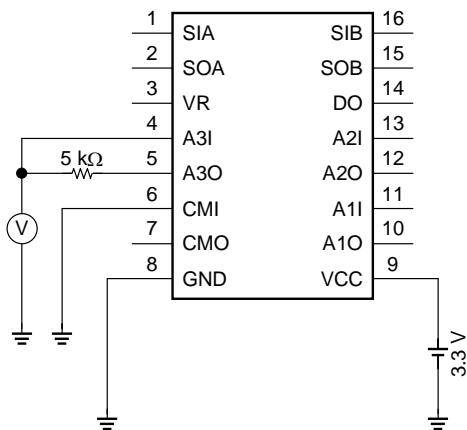

(14) OP-AMP3

Input current: I_{in}

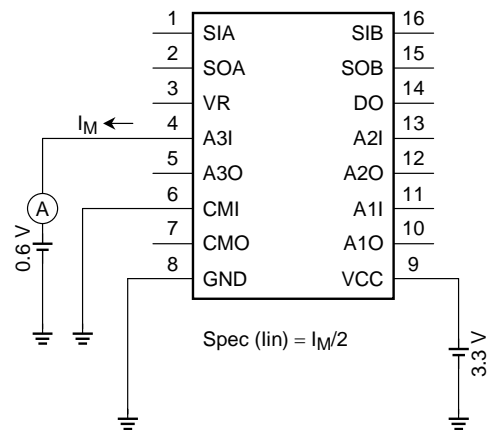

(15) OP-AMP3

Output source current: **I_{Aso}**

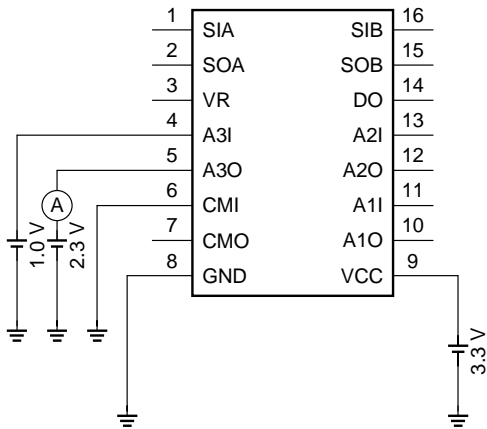

(16) OP-AMP3

Output sink current: **I_{A_{si}}**

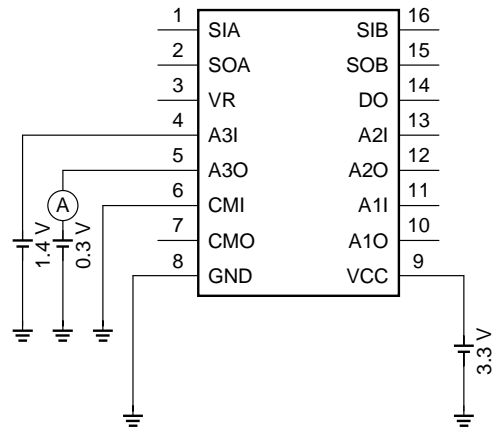

(17) Window comparator

Output pull-up resistance: **R_{Wu}**

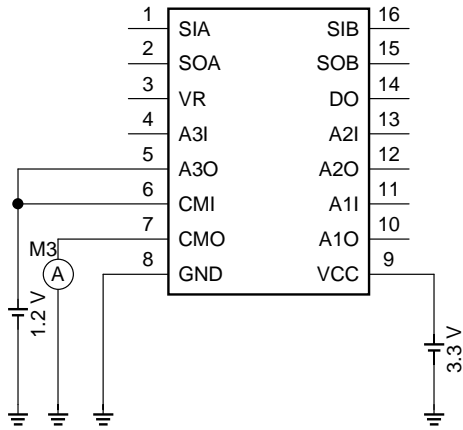

$$R_{Wu} = 3.3/M3$$

(18) Window comparator

Output sink current: **I_{w_{si}}**

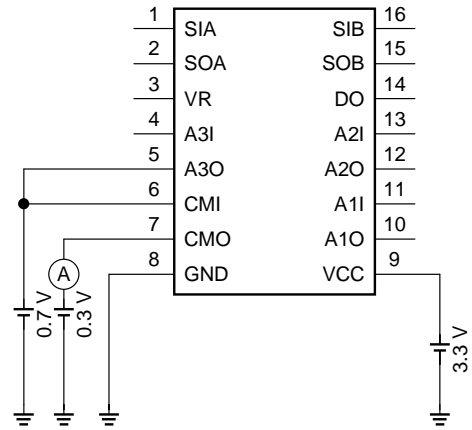

Package Dimensions

SSOP16-P-225-0.65B

Unit : mm

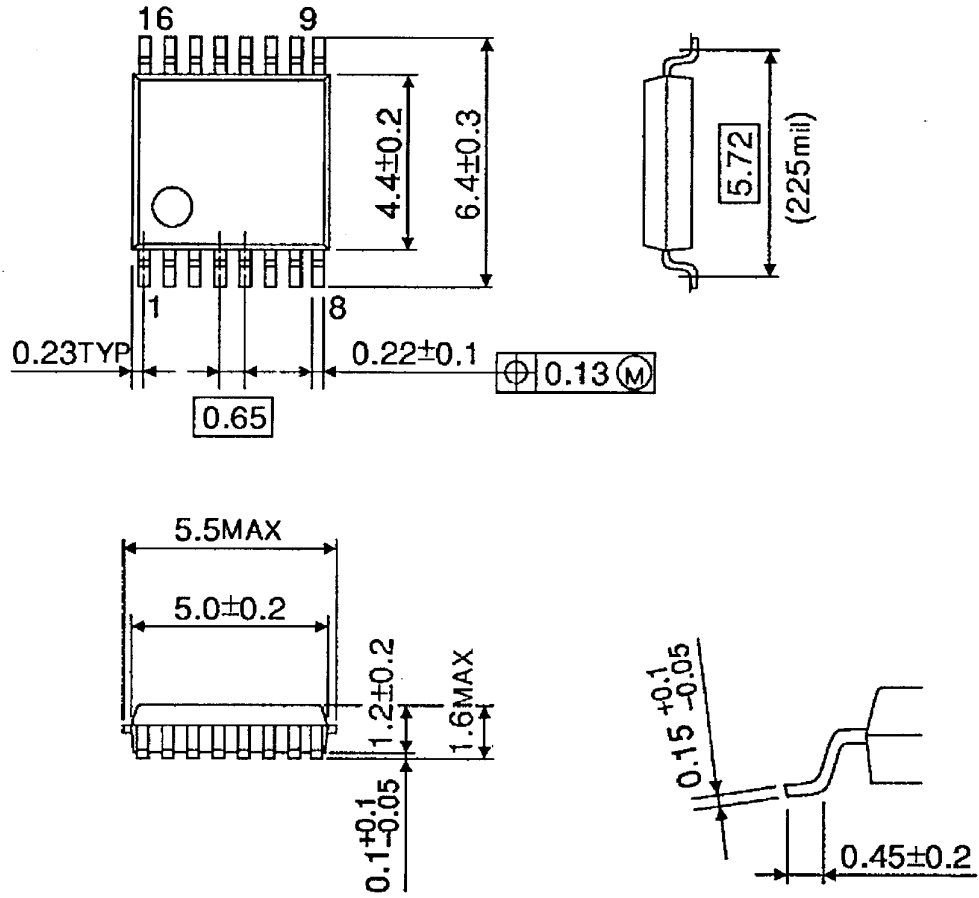

Weight: 0.07 g (typ.)

RESTRICTIONS ON PRODUCT USE

000707EAA

- TOSHIBA is continually working to improve the quality and reliability of its products. Nevertheless, semiconductor devices in general can malfunction or fail due to their inherent electrical sensitivity and vulnerability to physical stress. It is the responsibility of the buyer, when utilizing TOSHIBA products, to comply with the standards of safety in making a safe design for the entire system, and to avoid situations in which a malfunction or failure of such TOSHIBA products could cause loss of human life, bodily injury or damage to property.
In developing your designs, please ensure that TOSHIBA products are used within specified operating ranges as set forth in the most recent TOSHIBA products specifications. Also, please keep in mind the precautions and conditions set forth in the "Handling Guide for Semiconductor Devices," or "TOSHIBA Semiconductor Reliability Handbook" etc..
- The TOSHIBA products listed in this document are intended for usage in general electronics applications (computer, personal equipment, office equipment, measuring equipment, industrial robotics, domestic appliances, etc.). These TOSHIBA products are neither intended nor warranted for usage in equipment that requires extraordinarily high quality and/or reliability or a malfunction or failure of which may cause loss of human life or bodily injury ("Unintended Usage"). Unintended Usage include atomic energy control instruments, airplane or spaceship instruments, transportation instruments, traffic signal instruments, combustion control instruments, medical instruments, all types of safety devices, etc.. Unintended Usage of TOSHIBA products listed in this document shall be made at the customer's own risk.
- The information contained herein is presented only as a guide for the applications of our products. No responsibility is assumed by TOSHIBA CORPORATION for any infringements of intellectual property or other rights of the third parties which may result from its use. No license is granted by implication or otherwise under any intellectual property or other rights of TOSHIBA CORPORATION or others.
- The information contained herein is subject to change without notice.

Looking for pricing, stock, or lifecycle information?

Click below to explore more details on WIN SOURCE:

- [View TB6066FNG\(EL\) on WIN SOURCE](#)
- [Toshiba Semiconductor and Storage Information](#)

Optimize Your Supply Chain with WIN SOURCE Solutions

- ✓ Global Sourcing Solution
- ✓ Obsolete Management
- ✓ Cost Control Management
- ✓ Shortage Management
- ✓ Alternative Solution
- ✓ Excess Inventory Management