

TDA3663

Very low dropout voltage/quiescent current 3.3 V voltage regulator

Rev. 06 — 26 June 2007

Product data sheet

1. General description

The TDA3663 is a fixed 3.3 V voltage regulator with a very low dropout voltage and quiescent current, which operates over a wide supply voltage range.

2. Features

- Fixed 3.3 V, 100 mA regulator
- Supply voltage range up to 45 V
- Very low quiescent current of 15 μ A (typical value)
- Very low dropout voltage
- High ripple rejection
- Protections:
 - ◆ Reverse polarity safe (down to -25 V without high reverse current)
 - ◆ Negative transient of 50 V ($R_S = 10 \Omega$, $t < 100$ ms)
 - ◆ Able to withstand voltages up to 18 V at the output (supply line may be short-circuited)
 - ◆ ESD protection on all pins
 - ◆ DC short-circuit safe to ground and V_P of the regulator output
 - ◆ Temperature protection (at $T_j > 150$ °C)

3. Quick reference data

Table 1: Quick reference data

$V_P = 14.4\text{ V}$; $T_{amb} = 25\text{ °C}$; measured with test circuit of [Figure 15](#); unless otherwise specified.

Symbol	Parameter	Conditions	Min	Typ	Max	Unit
Supply voltage: pin V_P						
V_P	supply voltage	regulator operating	[1] 3	14.4	45	V
I_q	quiescent current	$V_P = 4.5\text{ V}$; $I_{REG} = 0\text{ mA}$	-	10	-	μA
		$V_P = 14.4\text{ V}$; $I_{REG} = 0\text{ mA}$	-	15	30	μA
		$6\text{ V} \leq V_P \leq 22\text{ V}$; $I_{REG} = 10\text{ mA}$	-	0.2	0.5	mA
		$6\text{ V} \leq V_P \leq 22\text{ V}$; $I_{REG} = 50\text{ mA}$	-	1.4	2.5	mA
Regulator output: pin REG						
V_{REG}	output voltage	$8\text{ V} \leq V_P \leq 22\text{ V}$; $I_{REG} = 0.5\text{ mA}$	3.16	3.3	3.44	V
		$0.5\text{ mA} \leq I_{REG} \leq 100\text{ mA}$	3.13	3.3	3.47	V
		$6\text{ V} \leq V_P \leq 45\text{ V}$; $I_{REG} = 0.5\text{ mA}$;	3.13	3.3	3.47	V
$V_{REG(drop)}$	dropout voltage	$V_P = 3.1\text{ V}$; $T_{amb} \leq 85\text{ °C}$; $I_{REG} = 50\text{ mA}$;	-	0.18	0.3	V

[1] The regulator output will follow V_P if $V_P < V_{REG} + V_{REG(drop)}$.

4. Ordering information

Table 2: Ordering information

Type number	Package		Version
	Name	Description	
TDA3663	SO4	plastic small outline package; 4 leads; body width 3.5 mm	SOT223-1
TDA3663AT	SO8	plastic small outline package; 8 leads; body width 3.9 mm	SOT96-1

5. Block diagram

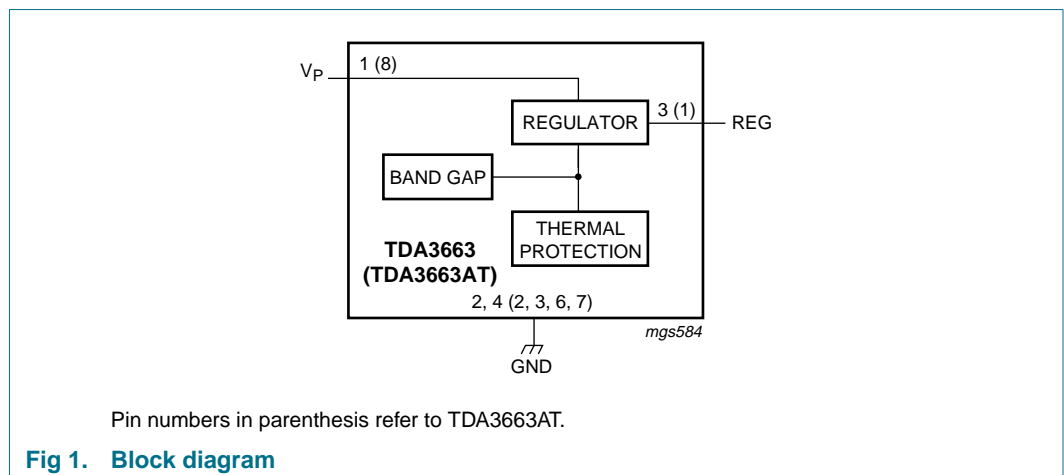

6. Pinning information

6.1 Pinning

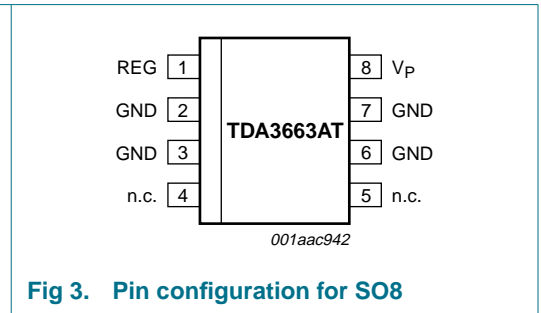
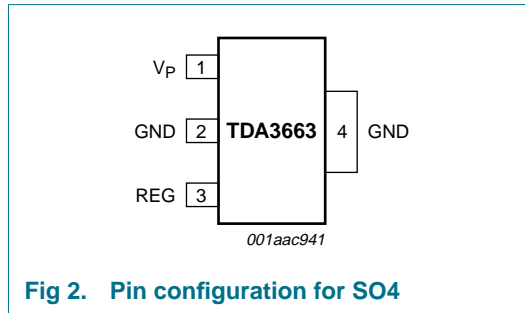

6.2 Pin description

Table 3: Pin description

Symbol	Pin		Description
	SO4	SO8	
V _P	1	8	supply voltage
GND	2 and 4	2, 3, 6 and 8	ground ^[1]
REG	3	1	regulator output
n.c.	-	4 and 5	not connected

[1] For the SO8 package all GND pins are connected to the lead frame and can also be used to reduce the total thermal resistance $R_{th(j-a)}$ by soldering these pins to a ground plane. The ground plane on the top side of the PCB acts like a heat spreader.

7. Functional description

The TDA3663 is a fixed 3.3 V regulator which can deliver output currents up to 100 mA. The regulator is available in SO8 and SO4 packages. The regulator is intended for portable, mains and telephone applications. To increase the lifetime of batteries, a specially built-in clamp circuit keeps the quiescent current of this regulator very low, also in dropout and full load conditions.

The device remains operational down to very low supply voltages and below this voltage it switches off.

A temperature protection circuit is included which switches off the regulator output at a junction temperature above 150 °C.

8. Limiting values

Table 4: Limiting values

In accordance with the Absolute Maximum Rating System (IEC 60134).

Symbol	Parameter	Conditions	Min	Max	Unit
V _P	supply voltage		-	45	V
V _{P(rp)}	reverse polarity supply voltage	non-operating	-	-25	V
P _{tot}	total power dissipation				
	TDA3663	temperature of copper area is 25 °C	-	4.1	W
	TDA3663AT	T _{amb} = 25 °C	-	5	W
T _{stg}	storage temperature	non-operating	-55	+150	°C
T _{amb}	ambient temperature	operating	-40	+125	°C
T _j	junction temperature	operating	-40	+150	°C

9. Thermal characteristics

Table 5: Thermal characteristics

Symbol	Parameter	Conditions	Typ	Unit
$R_{th(j-a)}$	thermal resistance from junction to ambient			
	SO4	in free air; soldered	100	K/W
	SO8	in free air; soldered	155	K/W
$R_{th(j-c)}$	thermal resistance from junction to case			
	SO4	to center pins; soldered	25	K/W
	SO8	to center pins; soldered	30	K/W

10. Characteristics

Table 6: Characteristics

$V_P = 14.4\text{ V}$; $T_{amb} = 25\text{ °C}$; measured with test circuit of [Figure 15](#); unless otherwise specified.

Symbol	Parameter	Conditions	Min	Typ	Max	Unit
Supply voltage: pin V_P						
V_P	supply voltage	regulator operating	[1] 3	14.4	45	V
I_q	quiescent current	$V_P = 4.5\text{ V}$; $I_{REG} = 0\text{ mA}$	-	10	-	μA
		$V_P = 14.4\text{ V}$; $I_{REG} = 0\text{ mA}$	-	15	30	μA
		$6\text{ V} \leq V_P \leq 22\text{ V}$; $I_{REG} = 10\text{ mA}$	-	0.2	0.5	mA
		$6\text{ V} \leq V_P \leq 22\text{ V}$; $I_{REG} = 50\text{ mA}$	-	1.4	2.5	mA
Regulator output: pin REG						
V_{REG}	output voltage	$8\text{ V} \leq V_P \leq 22\text{ V}$; $I_{REG} = 0.5\text{ mA}$	3.16	3.3	3.44	V
		$0.5\text{ mA} \leq I_{REG} \leq 100\text{ mA}$	3.13	3.3	3.47	V
		$6\text{ V} \leq V_P \leq 45\text{ V}$; $I_{REG} = 0.5\text{ mA}$	3.13	3.3	3.47	V
$V_{REG(drop)}$	dropout voltage	$V_P = 3.1\text{ V}$; $T_{amb} \leq 85\text{ °C}$; $I_{REG} = 50\text{ mA}$	-	0.18	0.3	V
$V_{REG(stab)}$	output voltage long-term stability	per 1000 h	-	20	-	mV
$\Delta V_{REG(line)}$	line input regulation voltage	$7\text{ V} \leq V_P \leq 22\text{ V}$; $I_{REG} = 0.5\text{ mA}$	-	1	30	mV
		$7\text{ V} \leq V_P \leq 45\text{ V}$; $I_{REG} = 0.5\text{ mA}$	-	1	50	mV
$\Delta V_{REG(load)}$	load output regulation voltage	$0.5\text{ mA} \leq I_{REG} \leq 50\text{ mA}$	-	10	50	mV
SVRR	supply voltage ripple rejection	$f_i = 120\text{ Hz}$; $V_{i(ripple)} = 1\text{ V (RMS)}$; $I_{REG} = 0.5\text{ mA}$	50	60	-	dB
$I_{REG(crl)}$	output current limit	$V_{REG} > 2.8\text{ V}$	0.17	0.25	-	A
$I_{LO(rp)}$	output leakage current at reverse polarity	$V_P = -15\text{ V}$; $V_{REG} \leq 0.3\text{ V}$	-	1	500	μA

[1] The regulator output will follow V_P if $V_P < V_{REG} + V_{REG(drop)}$.

11. Application information

11.1 Noise

The output noise is determined by the value of the output capacitor. The noise figure is measured at a bandwidth of 10 Hz to 100 kHz (see [Table 7](#)).

Table 7: Noise figures

Output current I_{REG} (mA)	Noise figure (μ V)		
	C2 = 10 μ F	C2 = 47 μ F	C2 = 100 μ F
0.5	550	320	300
50	650	400	400

11.2 Stability

For stable operation:

- The maximum output capacitor ESR should not exceed 22 Ω (worst-case) and for the minimum ESR, see [Table 8](#).
- The ESR of the output capacitor is limited.
- See [Table 8](#) for the minimum ESR values of the output capacitor, at T_{amb} given the load and output capacitance.

Remark: In the event of using different types of capacitors, a minimum ESR needs to be created by using an additional resistor that is placed in series with the output capacitor, see [Figure 4](#).

- It is recommended not to use below 1 mA output current because of reduced phase margin.

Table 8: Minimum ESR values required

I_{REG} (mA) max	C2 = 100 nF	C2 = 1 μ F	C2 = 10 μ F	C2 = 100 μ F
1	> 0 Ω	> 1.5 Ω	> 2.5 Ω	> 0 Ω
5	> 1 Ω	> 0.5 Ω	> 1 Ω	> 0 Ω
10	> 0 Ω	> 0.5 Ω	> 4 Ω	> 0 Ω
100	> 0 Ω	> 0.5 Ω	> 4 Ω	> 0 Ω

11.3 Application circuits

The maximum output current of the regulator equals:

$$I_{REG(max)} = \frac{150 - T_{amb}}{R_{th(j-a)} \times (V_P - V_{REG})} = \frac{150 - T_{amb}}{100 \times (V_P - 3.3)} (mA)$$

When $T_{amb} = 21$ °C and $V_P = 14$ V the maximum output current equals 116 mA.

The total thermal resistance of the TDA3663 can be decreased from 155 K/W to 30 K/W for the SO8 version. For the SO4 version it can be decreased from 100 K/W to 25 K/W when GND pins 2 and 4 of the package are soldered to the printed-circuit board.

11.3.1 Application circuit with backup function

Sometimes a backup function is needed to supply, for example, a microcontroller for a short period of time when the supply voltage spikes to 0 V (or even -1 V).

This function can easily be built with the TDA3663 by using an output capacitor with a large value. When the supply voltage is 0 V (or -1 V), only a small current will flow into pin REG from this output capacitor (a few μA).

The application circuit is given in [Figure 4](#).

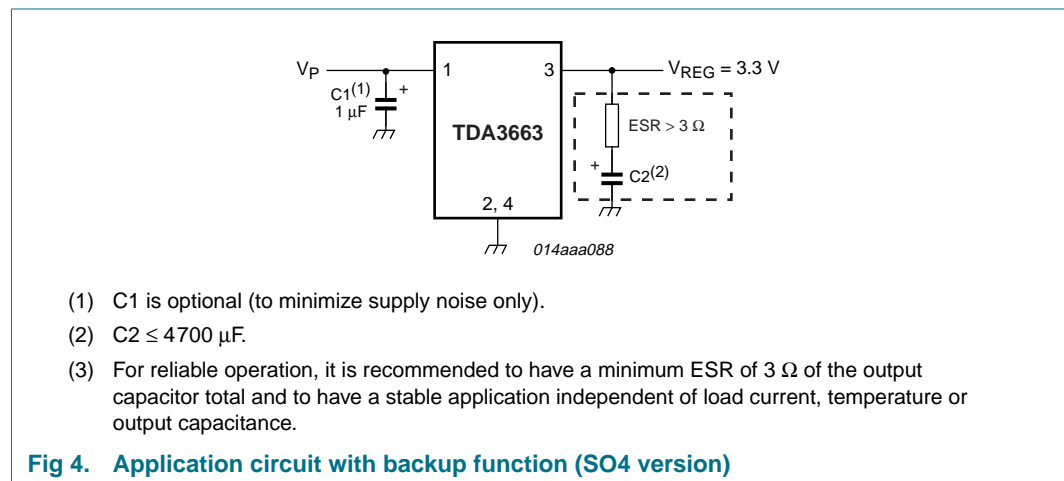

11.4 Additional application information

This section gives typical curves for various parameters measured on the TDA3663AT. Standard test conditions are: $V_P = 14.4\text{ V}$; $T_{amb} = 25\text{ }^\circ\text{C}$.

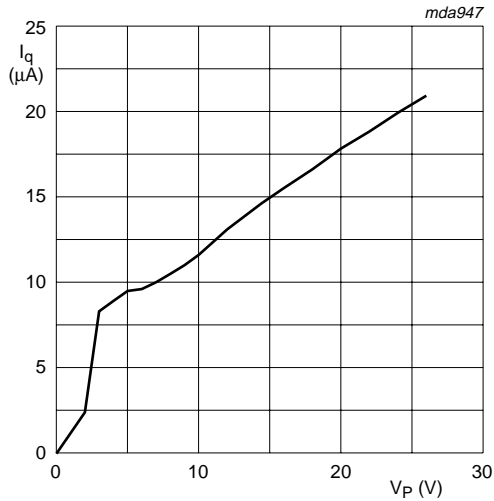

$I_{REG} = 0\text{ mA}$.

Fig 5. Quiescent current as a function of the supply voltage

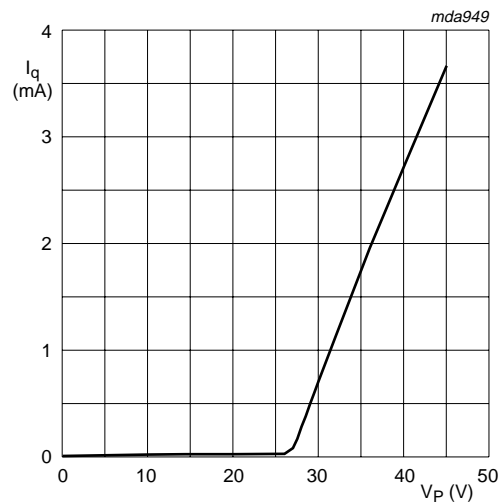
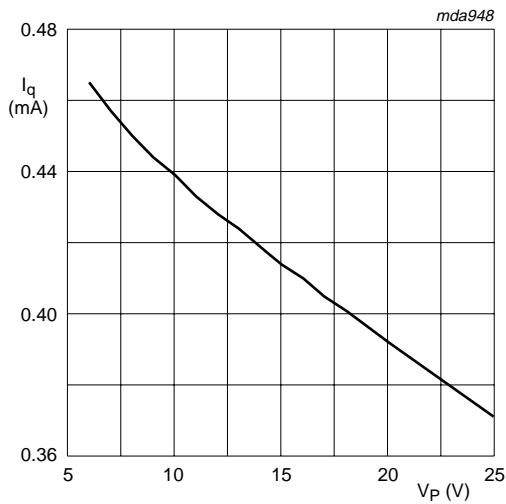
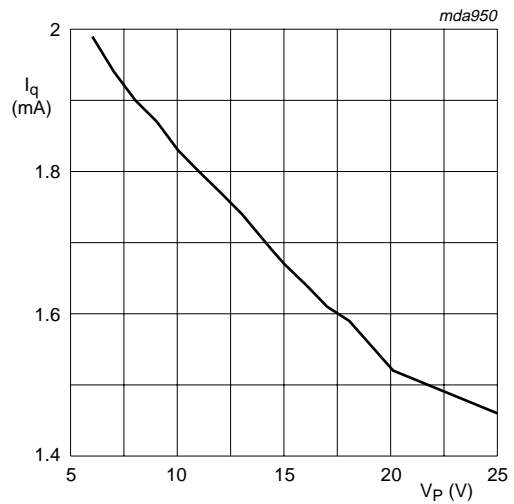

Fig 6. Quiescent current increase as a function of the high supply voltage



$I_{REG} = 10\text{ mA}$.

Fig 7. Quiescent current as a function of the supply voltage



$I_{REG} = 50\text{ mA}$.

Fig 8. Quiescent current as a function of the supply voltage

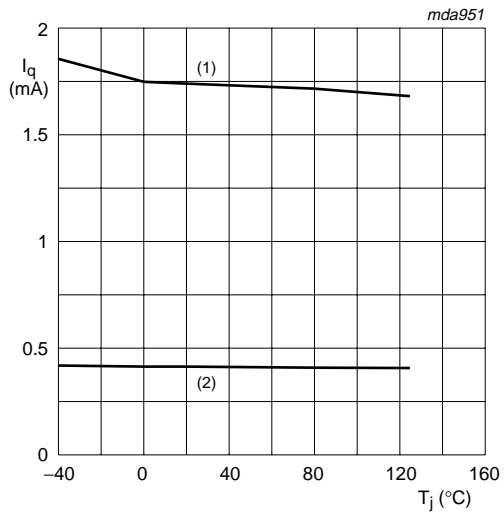

(1) I_q at 50 mA load.
 (2) I_q at 10 mA load.

Fig 9. Quiescent current as a function of the junction temperature

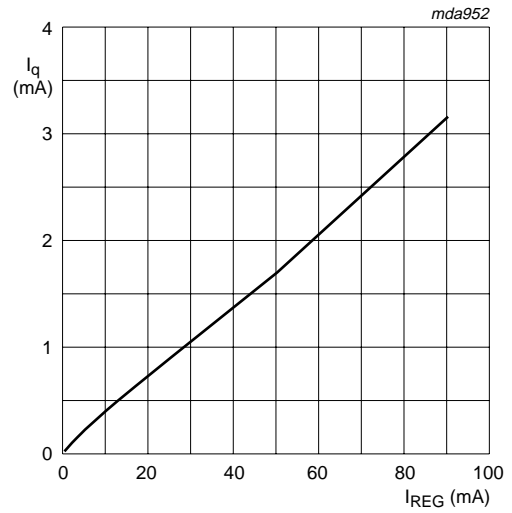
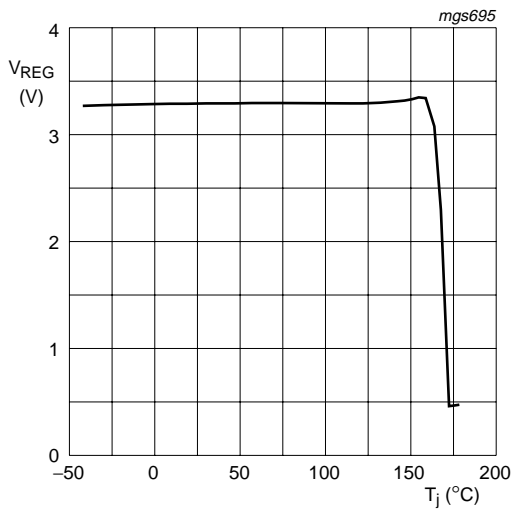

Fig 10. Quiescent current as a function of the output current



$I_{REG} = 0$ mA.

Fig 11. Output voltage thermal protection as a function of the junction temperature

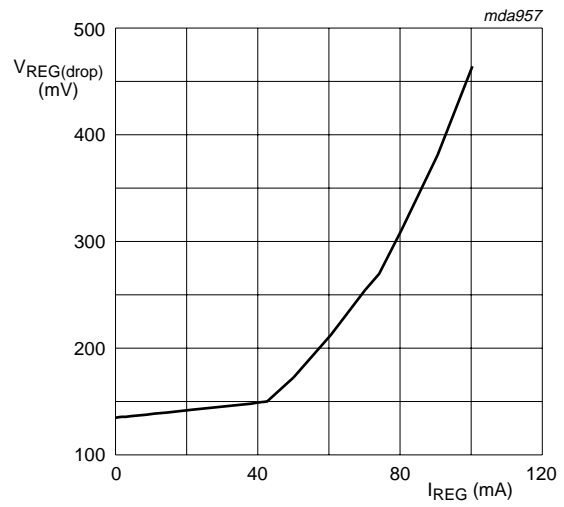
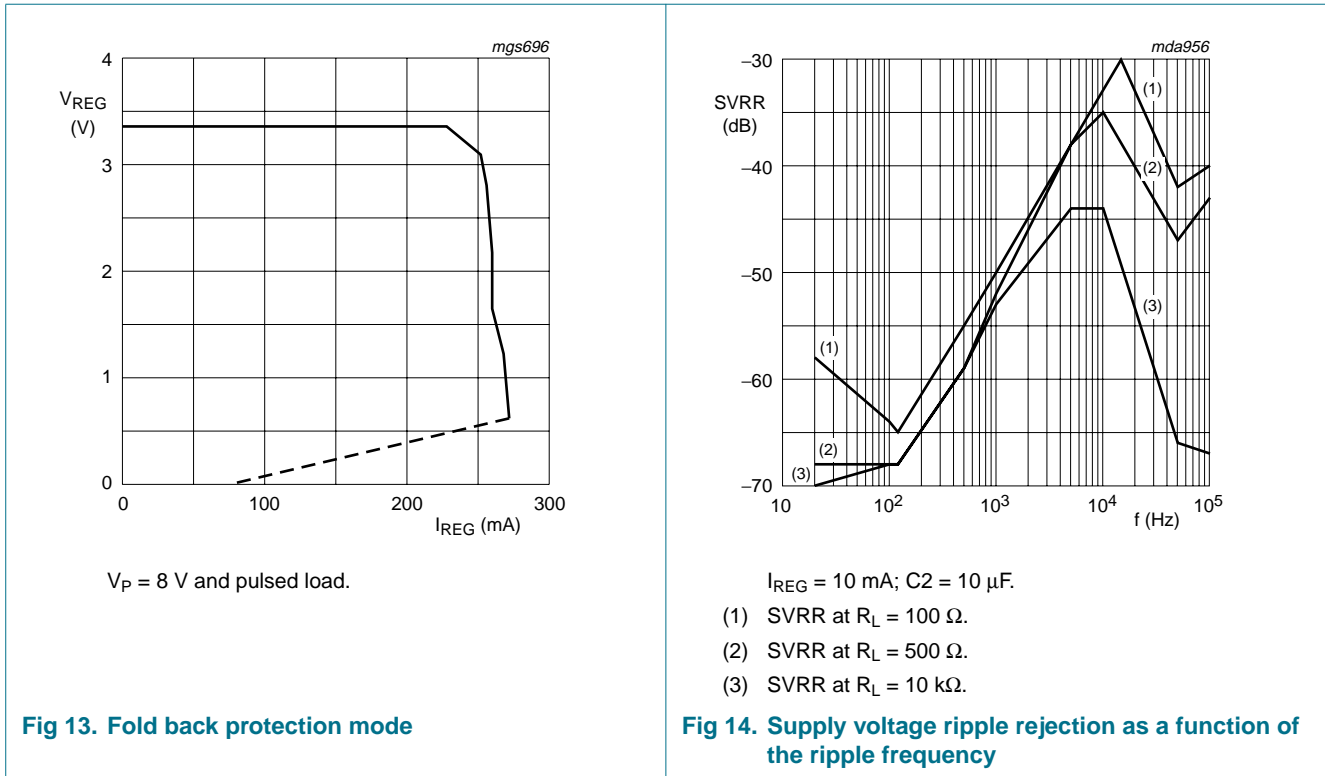
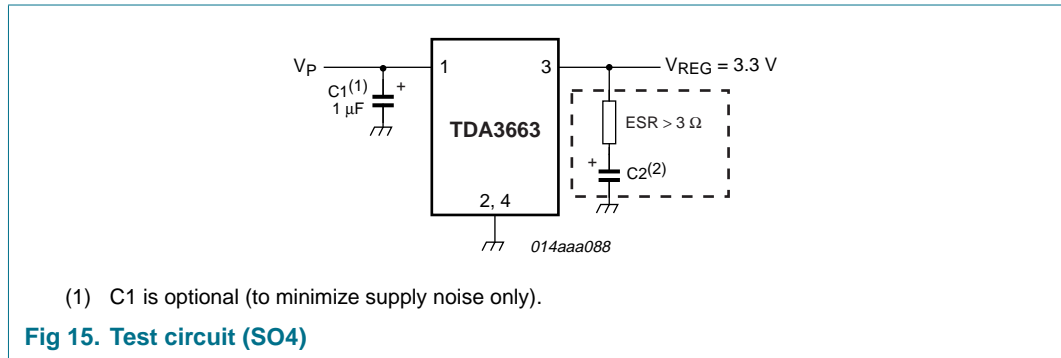

Fig 12. Dropout voltage as a function of the output current



12. Test information



12.1 Quality information

The *General Quality Specification for Integrated Circuits, SNW-FQ-611* is applicable.

13. Package outline

SO4: plastic small outline package; 4 leads; body width 3.5 mm

SOT223-1

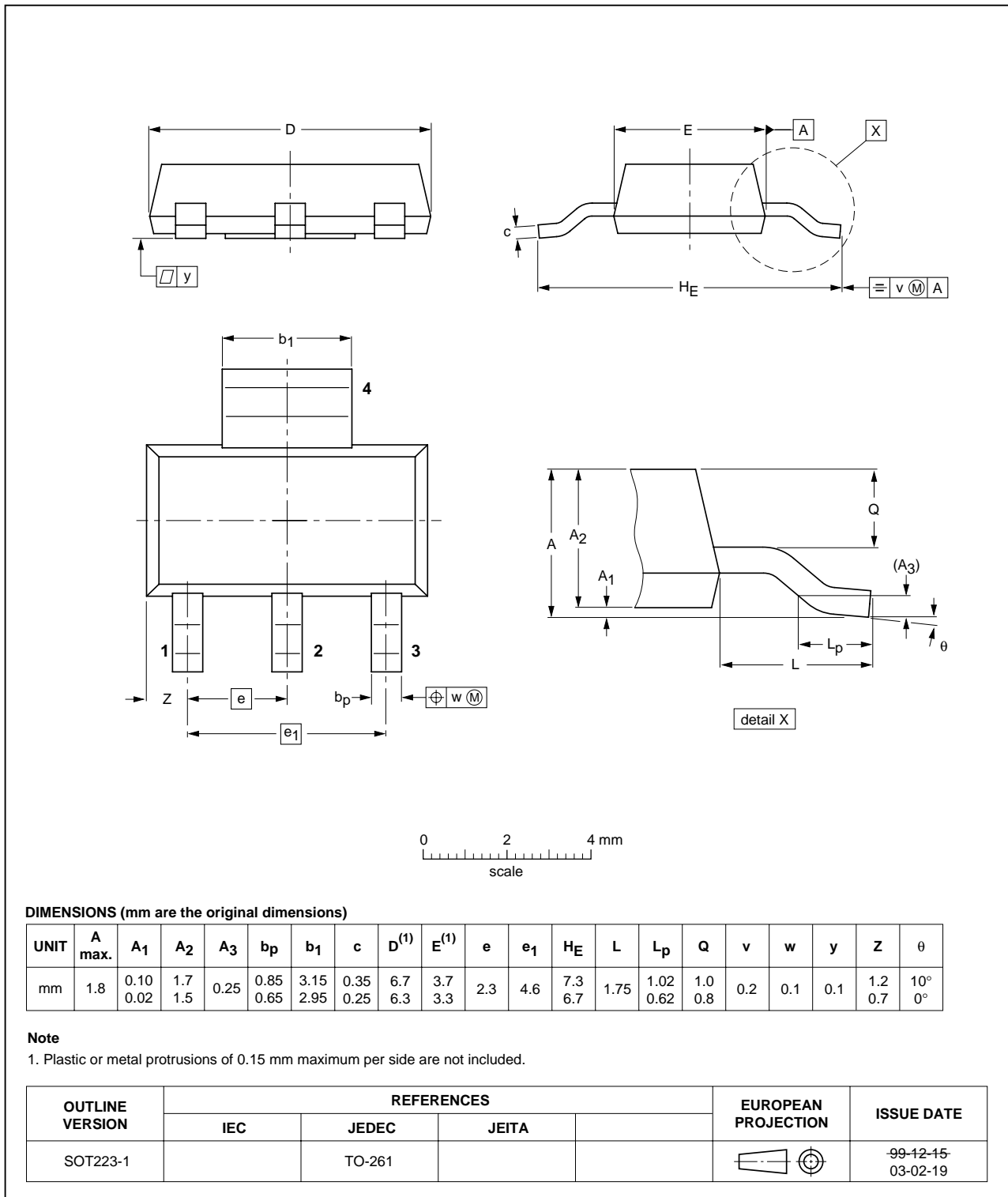

Fig 16. Package outline SOT223-1 (SO4)

SO8: plastic small outline package; 8 leads; body width 3.9 mm

SOT96-1

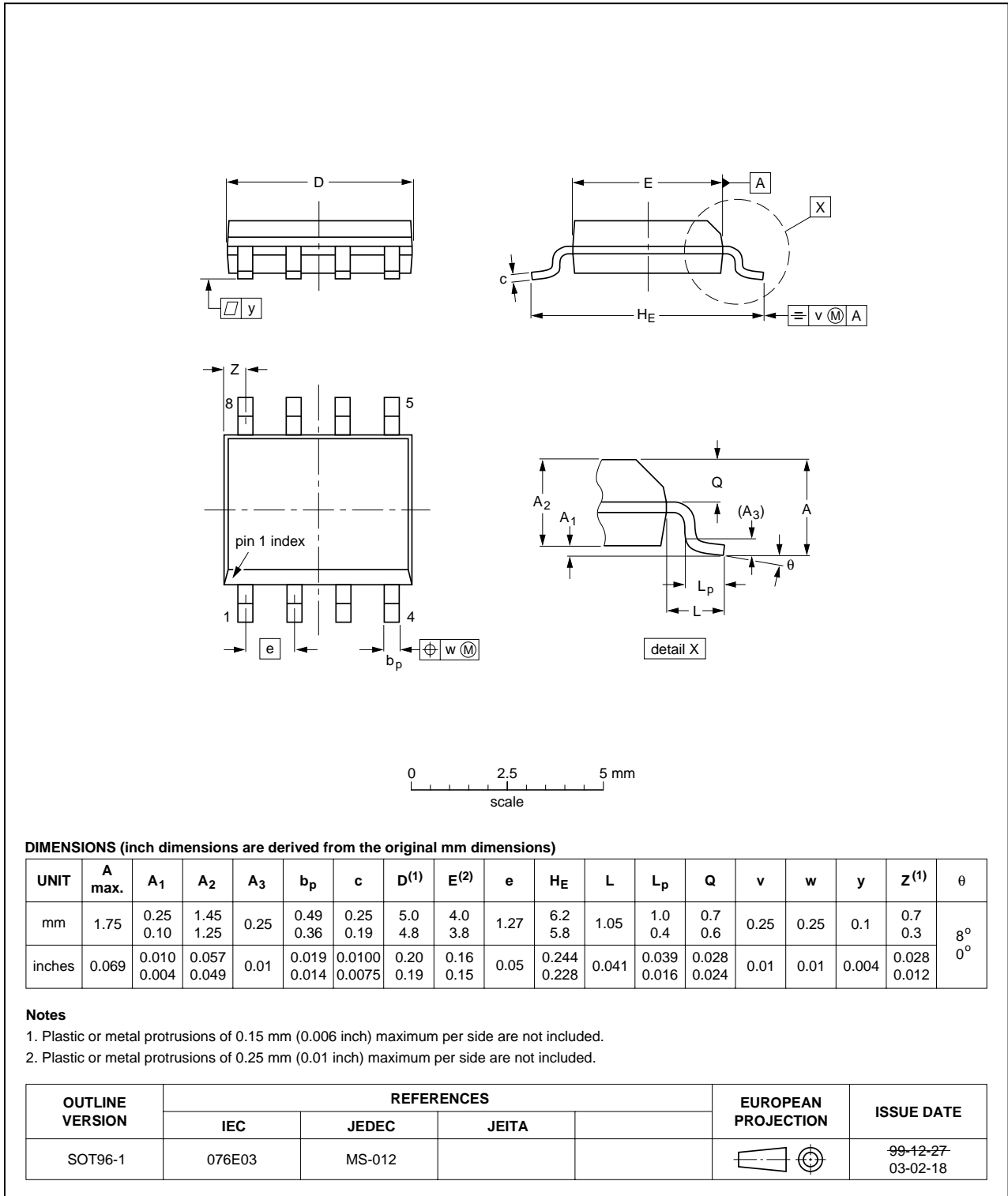

Fig 17. Package outline SOT96-1 (SO8)

14. Revision history

Table 9: Revision history

Document ID	Release date	Data sheet status	Change notice	Doc. number	Supersedes
TDA3663_6	20070626	Product data sheet	-	-	TDA3663_5
Modifications	<ul style="list-style-type: none"> • The format of this data sheet has been redesigned to comply with the new identity guidelines of NXP Semiconductors. • Legal texts have been adapted to the new company name where appropriate. • Minor changes made to bulleted list in Section 11.2 • Minor changes made to Table 8 • Component additions to Figure 4 and Figure 15. 				
TDA3663_5	20050613	Product data sheet	-	9397 750 15047	TDA3663_4
TDA3663_4	20001214	Product specification	-	9397 750 07864	TDA3663_3
TDA3663_3	20001208	Preliminary specification	-	9397 750 07555	TDA3663_2
TDA3663_2	20000201	Preliminary specification	-	9397 750 06798	TDA3663_1
TDA3663_1	19990929	Preliminary specification	-	9397 750 06068	-

15. Legal information

15.1 Data sheet status

Document status ^{[1][2]}	Product status ^[3]	Definition
Objective [short] data sheet	Development	This document contains data from the objective specification for product development.
Preliminary [short] data sheet	Qualification	This document contains data from the preliminary specification.
Product [short] data sheet	Production	This document contains the product specification.

[1] Please consult the most recently issued document before initiating or completing a design.

[2] The term 'short data sheet' is explained in section "Definitions".

[3] The product status of device(s) described in this document may have changed since this document was published and may differ in case of multiple devices. The latest product status information is available on the Internet at URL <http://www.nxp.com>.

15.2 Definitions

Draft — The document is a draft version only. The content is still under internal review and subject to formal approval, which may result in modifications or additions. NXP Semiconductors does not give any representations or warranties as to the accuracy or completeness of information included herein and shall have no liability for the consequences of use of such information.

Short data sheet — A short data sheet is an extract from a full data sheet with the same product type number(s) and title. A short data sheet is intended for quick reference only and should not be relied upon to contain detailed and full information. For detailed and full information see the relevant full data sheet, which is available on request via the local NXP Semiconductors sales office. In case of any inconsistency or conflict with the short data sheet, the full data sheet shall prevail.

15.3 Disclaimers

General — Information in this document is believed to be accurate and reliable. However, NXP Semiconductors does not give any representations or warranties, expressed or implied, as to the accuracy or completeness of such information and shall have no liability for the consequences of use of such information.

Right to make changes — NXP Semiconductors reserves the right to make changes to information published in this document, including without limitation specifications and product descriptions, at any time and without notice. This document supersedes and replaces all information supplied prior to the publication hereof.

Suitability for use — NXP Semiconductors products are not designed, authorized or warranted to be suitable for use in medical, military, aircraft, space or life support equipment, nor in applications where failure or

malfunction of a NXP Semiconductors product can reasonably be expected to result in personal injury, death or severe property or environmental damage. NXP Semiconductors accepts no liability for inclusion and/or use of NXP Semiconductors products in such equipment or applications and therefore such inclusion and/or use is at the customer's own risk.

Applications — Applications that are described herein for any of these products are for illustrative purposes only. NXP Semiconductors makes no representation or warranty that such applications will be suitable for the specified use without further testing or modification.

Limiting values — Stress above one or more limiting values (as defined in the Absolute Maximum Ratings System of IEC 60134) may cause permanent damage to the device. Limiting values are stress ratings only and operation of the device at these or any other conditions above those given in the Characteristics sections of this document is not implied. Exposure to limiting values for extended periods may affect device reliability.

Terms and conditions of sale — NXP Semiconductors products are sold subject to the general terms and conditions of commercial sale, as published at <http://www.nxp.com/profile/terms>, including those pertaining to warranty, intellectual property rights infringement and limitation of liability, unless explicitly otherwise agreed to in writing by NXP Semiconductors. In case of any inconsistency or conflict between information in this document and such terms and conditions, the latter will prevail.

No offer to sell or license — Nothing in this document may be interpreted or construed as an offer to sell products that is open for acceptance or the grant, conveyance or implication of any license under any copyrights, patents or other industrial or intellectual property rights.

15.4 Trademarks

Notice: All referenced brands, product names, service names and trademarks are the property of their respective owners.

16. Contact information

For additional information, please visit: <http://www.nxp.com>

For sales office addresses, send an email to: salesaddresses@nxp.com

17. Contents

1 **General description** 1

2 **Features** 1

3 **Quick reference data** 2

4 **Ordering information** 2

5 **Block diagram** 2

6 **Pinning information** 3

6.1 Pinning 3

6.2 Pin description 4

7 **Functional description** 4

8 **Limiting values** 4

9 **Thermal characteristics** 5

10 **Characteristics** 5

11 **Application information** 6

11.1 Noise 6

11.2 Stability 6

11.3 Application circuits 6

11.3.1 Application circuit with backup function 7

11.4 Additional application information 8

12 **Test information** 10

12.1 Quality information 10

13 **Package outline** 11

14 **Revision history** 13

15 **Legal information** 14

15.1 Data sheet status 14

15.2 Definitions 14

15.3 Disclaimers 14

15.4 Trademarks 14

16 **Contact information** 14

17 **Contents** 15

Please be aware that important notices concerning this document and the product(s) described herein, have been included in section 'Legal information'.



© NXP B.V. 2007.



All rights reserved.

For more information, please visit: <http://www.nxp.com>
 For sales office addresses, please send an email to: salesaddresses@nxp.com

Date of release: 26 June 2007
 Document identifier: TDA3663_6

Looking for pricing, stock, or lifecycle information?

Click below to explore more details on WIN SOURCE:

-  [View TDA3663 on WIN SOURCE](#)
-  [NXP / Nexperia Information](#)

Optimize Your Supply Chain with WIN SOURCE Solutions

-  Global Sourcing Solution
-  Obsolete Management
-  Cost Control Management
-  Shortage Management
-  Alternative Solution
-  Excess Inventory Management