



**THE DATASHEET OF
TDA8579T/N1SJ**



TDA8579T

Dual common-mode rejection differential line receiver

Rev. 4 — 23 September 2013

Product data sheet

1. General description

The TDA8579T is a two channel differential amplifier with 0 dB gain and low distortion. The device has been primarily developed for car radio applications where long connections between signal sources and amplifiers (or boosters) are necessary and where ground noise has to be eliminated. The device is intended to be used to receive line inputs in audio applications that require a high level of common-mode rejection. The device is contained in an 8-pin Small Outline (SO) package.

2. Features and benefits

- Excellent common-mode rejection, up to high frequencies
- Elimination of source resistance dependency in the common-mode rejection
- Few external components
- High supply voltage ripple rejection
- Low noise
- Low distortion
- All pins protected against electrostatic discharge
- AC and DC short-circuit safe to ground and V_{CC}
- Fast DC settling

3. Quick reference data

Table 1. Quick reference data

Symbol	Parameter	Conditions	Min	Typ	Max	Unit
V_{CC}	supply voltage		5.0	8.5	18	V
I_{CC}	supply current	$V_{CC} = 8.5\text{ V}$	-	11	14	mA
G_V	voltage gain		-0.5	0	+0.5	dB
SVRR	supply voltage ripple rejection		55	60	-	dB
V_{no}	noise output voltage		-	3.7	5.0	μV
$ Z_i $	input impedance		100	240	-	k Ω
CMRR	common-mode rejection ratio	$R_s = 0\ \Omega$	-	80	-	dB



4. Ordering information

Table 2. Ordering information

Type number	Package		Version
	Name	Description	
TDA8579T	SO8	plastic small outline package; 8 leads; body width 3.9 mm	SOT96-1

5. Block diagram

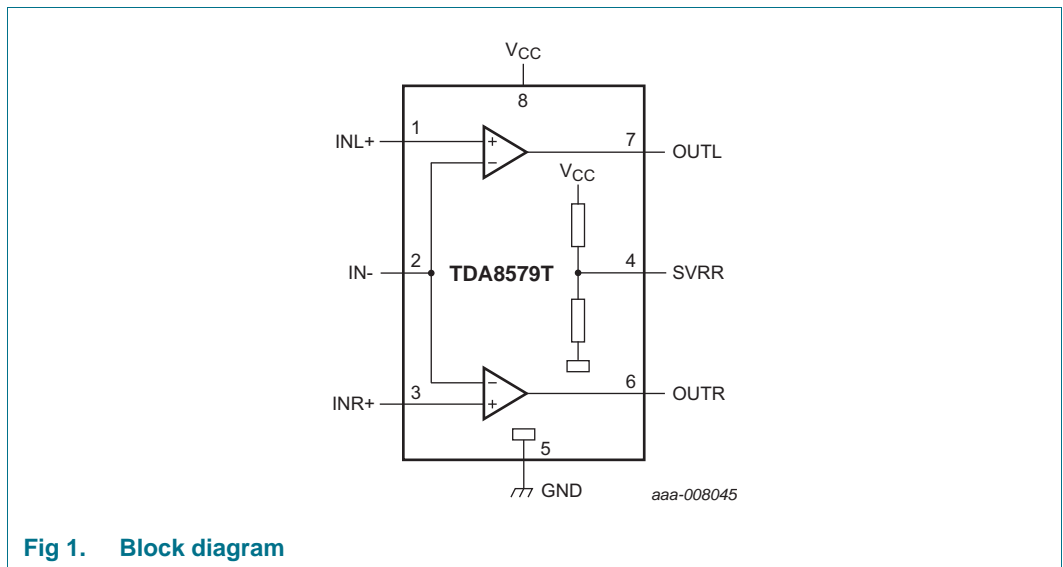

6. Pinning information

6.1 Pinning

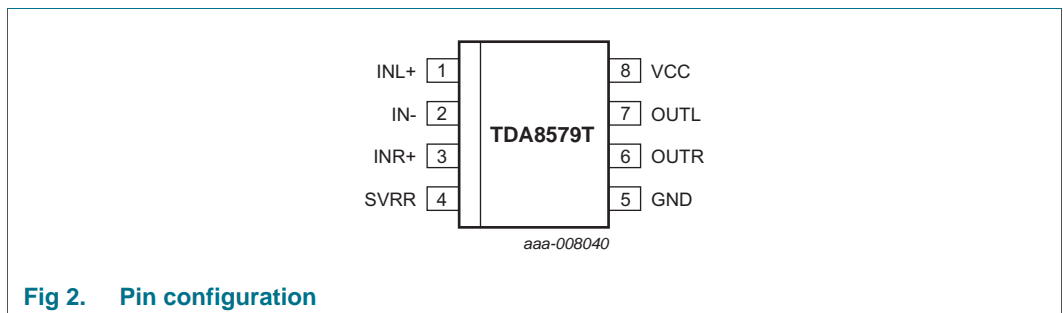

6.2 Pin description

Table 3. Pin description

Symbol	Pin	Description
INL+	1	positive input left
IN-	2	common negative input
INR+	3	positive input right
SVRR	4	half supply voltage
GND	5	ground
OUTR	6	output right
OUTL	7	output left
V _{cc}	8	supply voltage

7. Functional description

The TDA8579T contains two identical differential amplifiers with a voltage gain of 0 dB. The device is intended to receive line input signals for audio applications. The TDA8579T has a very high level of common-mode rejection and thus eliminates ground noise. The common-mode rejection remains constant up to high frequencies (the amplifier gain is fixed at 0 dB). The inputs have a high input impedance. The output stage is a class AB stage with a low output impedance. For a large common-mode rejection, also at low frequencies, an electrolytic capacitor connected to the negative input is advised. Because the input impedance is relatively high, this results in a large settling time of the DC input voltage. Therefore a quick-charge circuit is included to charge the input capacitor within 0.2 seconds.

All input and output pins are protected against high electrostatic discharge conditions (4000 V, 150 pF, 150 Ω).

8. Limiting values

Table 4. Limiting values

In accordance with the Absolute Maximum Rating System (IEC 60134). All voltages and currents are referenced to GND unless otherwise specified.

Symbol	Parameter	Conditions	Min	Max	Unit
V_{CC}	supply voltage		-	18	V
I_{ORM}	repetitive peak output current		-	40	mA
V_{sc}	AC and DC short-circuit safe voltage		-	18	V
T_{stg}	storage temperature		-55	+150	°C
T_{amb}	ambient temperature		-40	+85	°C
T_j	maximum junction temperature		-	150	°C

9. Thermal characteristics

Table 5. Thermal characteristics

According to IEC 60747-1.

Symbol	Parameter	Conditions	Value	Unit
$R_{th(j-a)}$	thermal resistance from junction to ambient	in free air	160	K/W

10. Characteristics

Table 6. Electrical characteristics

$V_{CC} = 8.5\text{ V}$; $T_{amb} = 25\text{ °C}$; test circuit (see [Figure 3](#)); unless otherwise specified.

Symbol	Parameter	Conditions	Min	Typ	Max	Unit
V_{CC}	supply voltage		5.0	8.5	18	V
I_{CC}	supply current		-	11	14	mA
V_O	output voltage		[1] -	4.3	-	V
t_{set}	DC input voltage settling time		-	0.2	-	s
G_V	voltage gain		-0.5	0	+0.5	dB
α_{cs}	channel separation	$R_s = 5\text{ k}\Omega$	70	80	-	dB
$ \Delta G_V $	channel unbalance		-	-	0.5	dB
f_L	LOW frequency roll-off	-1 dB	[2] 20	-	-	Hz
f_H	HIGH frequency roll-off	-1 dB	20	-	-	kHz
$ Z_i $	input impedance		100	240	-	k Ω
$ Z_o $	output impedance		-	-	10	Ω
$V_{i(max)}$	maximum input voltage	THD = 1 %	-	2.0	-	V
V_{no}	noise output voltage	$R_s = 0\ \Omega$	[3] -	3.7	5.0	μV
$V_{CM(rms)}$	common-mode input voltage (RMS value)		-	-	1.0	V
CMRR	common-mode rejection ratio	$R_s = 5\text{ k}\Omega$	66	70	-	dB
		$R_s = 0\ \Omega$	[4] -	80	-	dB
SVRR	supply voltage ripple rejection		[5] 55	65	-	dB
			[6] -	60	-	dB
THD	total harmonic distortion	$V_i = 1\text{ V}$;	-	0.02	-	%
		$V_i = 1\text{ V}$; $f = 20\text{ Hz to }20\text{ kHz}$	-	-	0.1	%
THD _{max}	total harmonic distortion at maximum output current	$V_i = 1\text{ V}$; $R_L = 150\ \Omega$	-	-	1	%

[1] The DC output voltage with respect to ground is approximately $0.5V_{CC}$.

[2] The input coupling capacitors set the frequency response externally.

[3] The noise output voltage is measured in a bandwidth of 20 Hz to 20 kHz (unweighted).

[4] The common-mode rejection ratio is measured at the output with a voltage source 1 V (RMS) in accordance with the test circuit (see [Figure 3](#)). V_{iNL} and V_{iNR} are short-circuited. Frequencies are between 100 Hz and 100 kHz.

[5] The ripple rejection is measured at the output, with $R_s = 2\text{ k}\Omega$, $f = 1\text{ kHz}$ and a ripple amplitude of 2 V (p-p).

[6] The ripple rejection is measured at the output. $R_s = 0\ \Omega$ to $2\text{ k}\Omega$, $f = 100\text{ Hz to }20\text{ kHz}$ and a maximum ripple amplitude of 2 V (p-p).

11. Application information

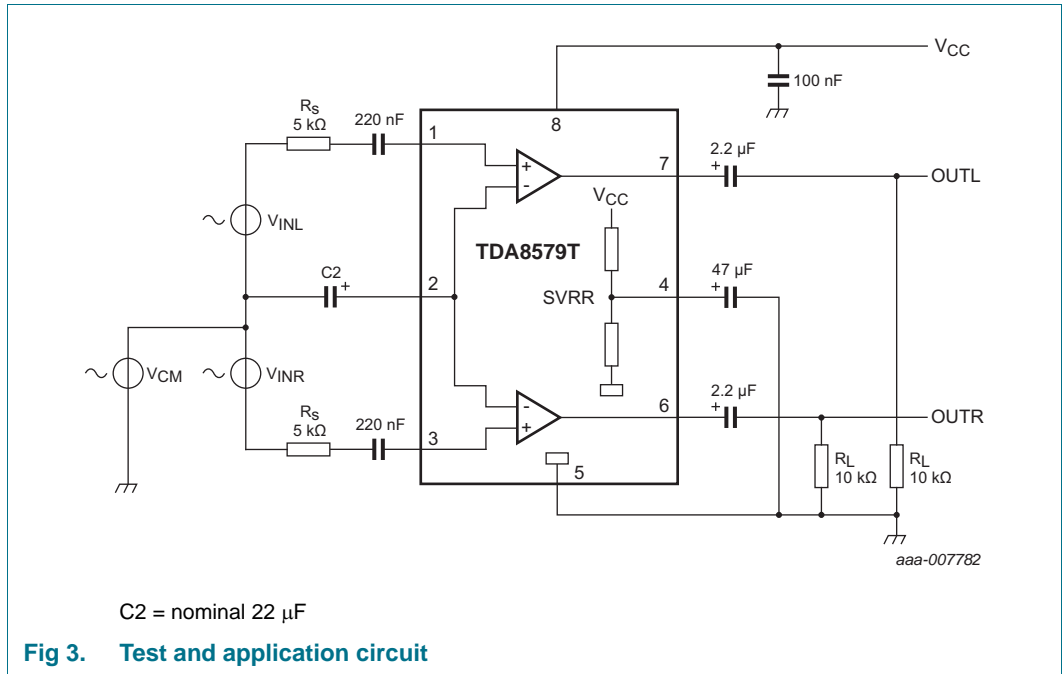

Fig 3. Test and application circuit

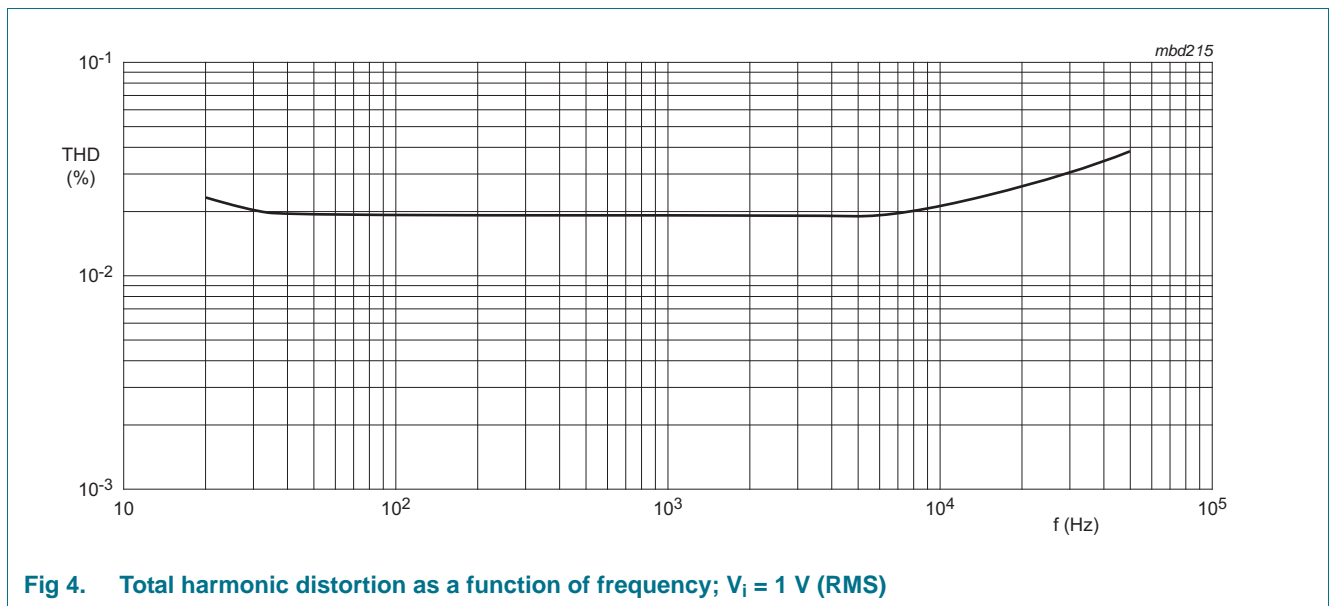
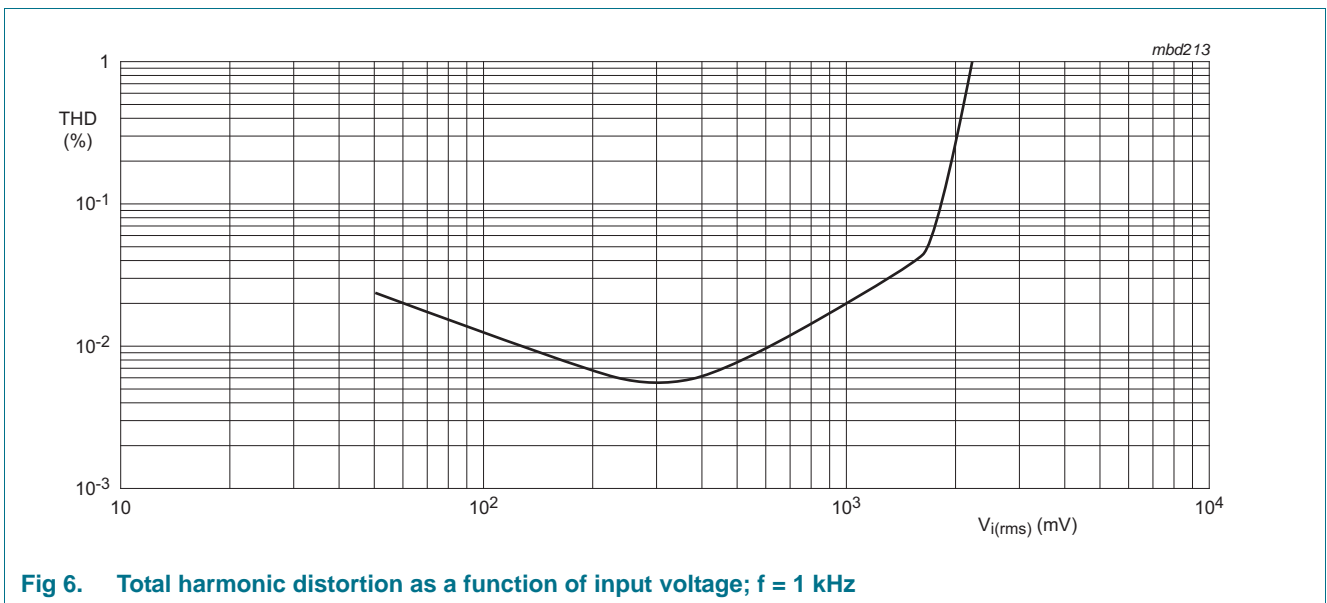
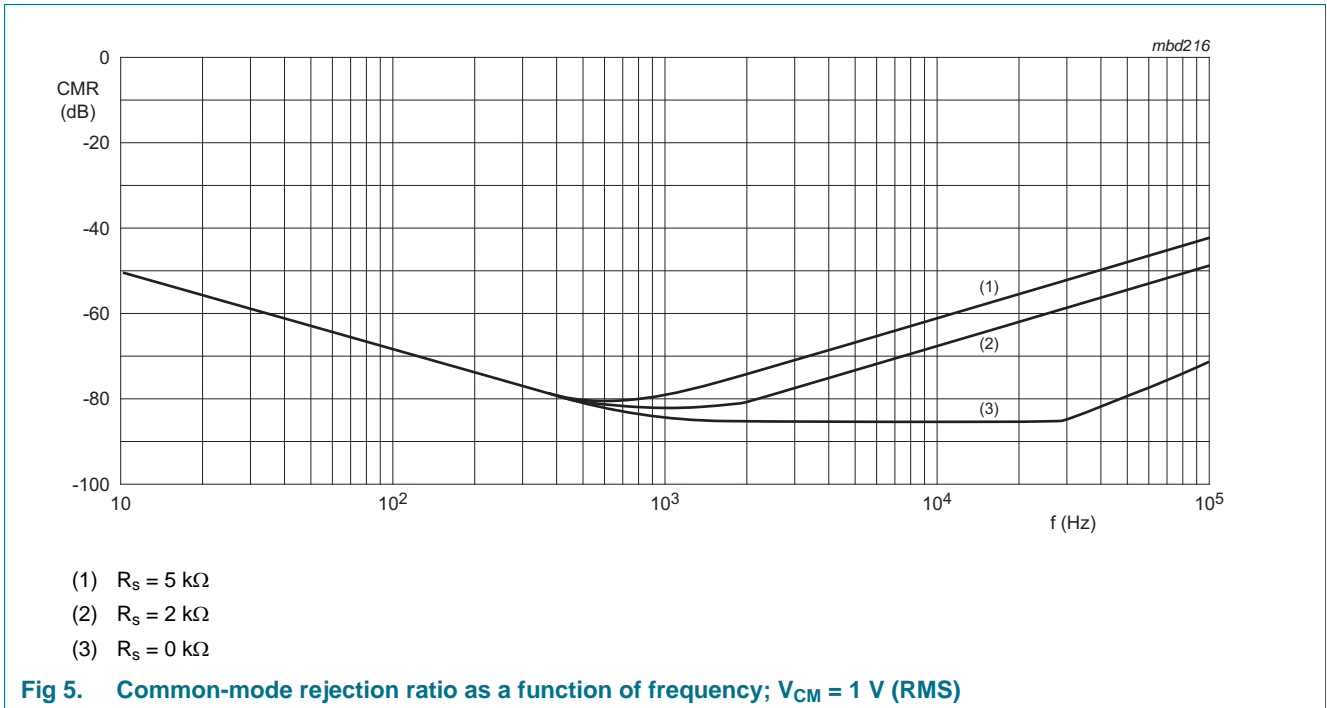

Fig 4. Total harmonic distortion as a function of frequency; $V_i = 1$ V (RMS)



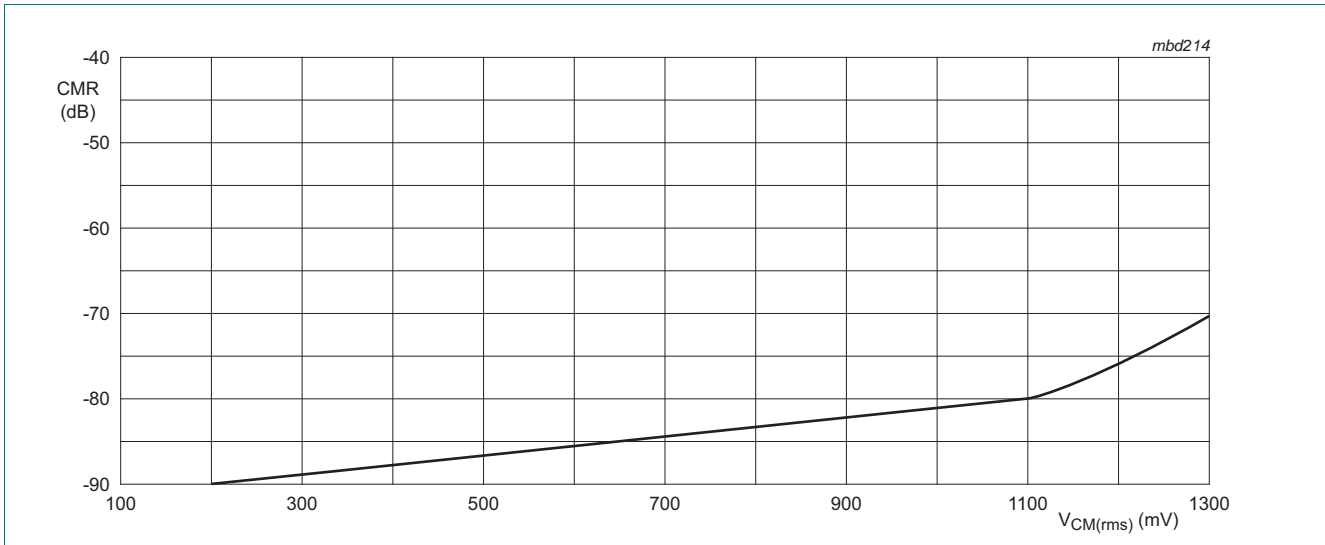
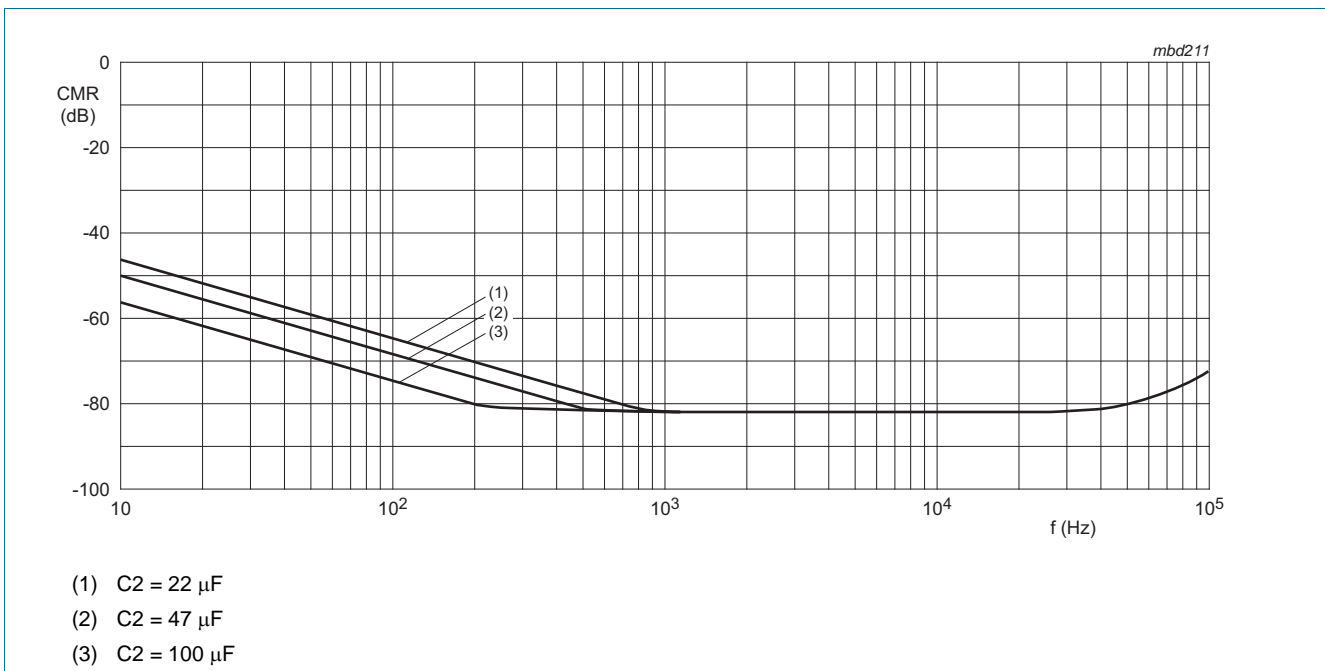
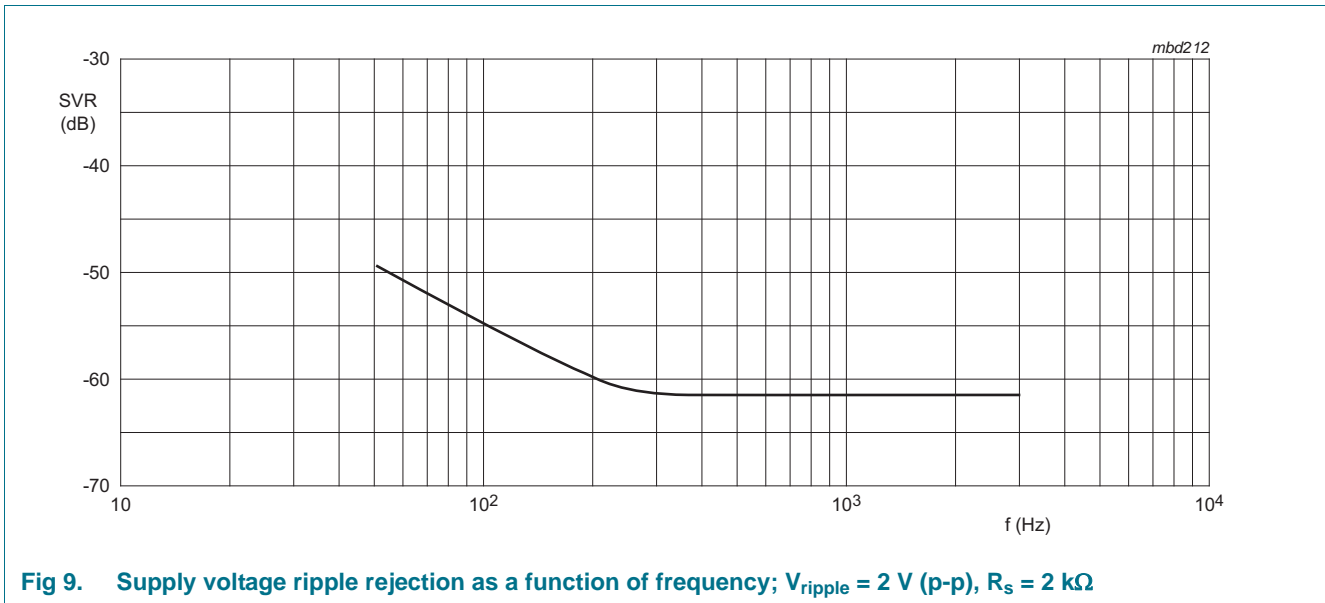

Fig 7. Common-mode rejection ratio as a function of common-mode input voltage; $f = 1 \text{ kHz}$, $R_s = 0 \Omega$



- (1) $C_2 = 22 \mu\text{F}$
- (2) $C_2 = 47 \mu\text{F}$
- (3) $C_2 = 100 \mu\text{F}$

Fig 8. Common-mode rejection ratio as a function of frequency; $V_{CM} = 1 \text{ V (RMS)}$



12. Package outline

SO8: plastic small outline package; 8 leads; body width 3.9 mm

SOT96-1

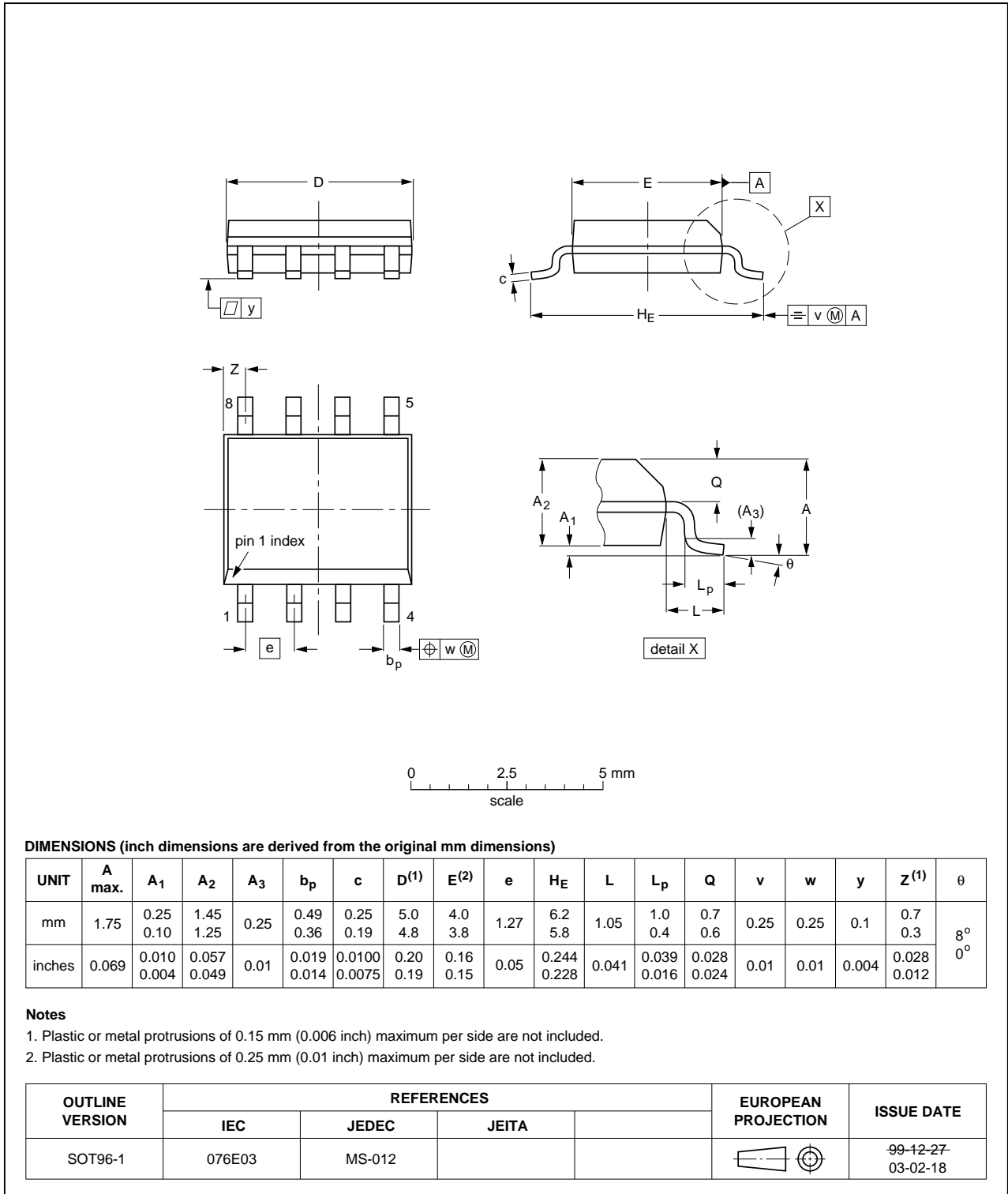

Fig 10. Package outline SOT96-1 (SO8)

13. Handling information

All input and output pins are protected against ElectroStatic Discharge (ESD) under normal handling. When handling ensure that the appropriate precautions are taken as described in *JESD625-A* or equivalent standards.

14. Soldering of SMD packages

This text provides a very brief insight into a complex technology. A more in-depth account of soldering ICs can be found in Application Note *AN10365 "Surface mount reflow soldering description"*.

14.1 Introduction to soldering

Soldering is one of the most common methods through which packages are attached to Printed Circuit Boards (PCBs), to form electrical circuits. The soldered joint provides both the mechanical and the electrical connection. There is no single soldering method that is ideal for all IC packages. Wave soldering is often preferred when through-hole and Surface Mount Devices (SMDs) are mixed on one printed wiring board; however, it is not suitable for fine pitch SMDs. Reflow soldering is ideal for the small pitches and high densities that come with increased miniaturization.

14.2 Wave and reflow soldering

Wave soldering is a joining technology in which the joints are made by solder coming from a standing wave of liquid solder. The wave soldering process is suitable for the following:

- Through-hole components
- Leaded or leadless SMDs, which are glued to the surface of the printed circuit board

Not all SMDs can be wave soldered. Packages with solder balls, and some leadless packages which have solder lands underneath the body, cannot be wave soldered. Also, leaded SMDs with leads having a pitch smaller than ~0.6 mm cannot be wave soldered, due to an increased probability of bridging.

The reflow soldering process involves applying solder paste to a board, followed by component placement and exposure to a temperature profile. Leaded packages, packages with solder balls, and leadless packages are all reflow solderable.

Key characteristics in both wave and reflow soldering are:

- Board specifications, including the board finish, solder masks and vias
- Package footprints, including solder thieves and orientation
- The moisture sensitivity level of the packages
- Package placement
- Inspection and repair
- Lead-free soldering versus SnPb soldering

14.3 Wave soldering

Key characteristics in wave soldering are:

- Process issues, such as application of adhesive and flux, clinching of leads, board transport, the solder wave parameters, and the time during which components are exposed to the wave
- Solder bath specifications, including temperature and impurities

14.4 Reflow soldering

Key characteristics in reflow soldering are:

- Lead-free versus SnPb soldering; note that a lead-free reflow process usually leads to higher minimum peak temperatures (see [Figure 11](#)) than a SnPb process, thus reducing the process window
- Solder paste printing issues including smearing, release, and adjusting the process window for a mix of large and small components on one board
- Reflow temperature profile; this profile includes preheat, reflow (in which the board is heated to the peak temperature) and cooling down. It is imperative that the peak temperature is high enough for the solder to make reliable solder joints (a solder paste characteristic). In addition, the peak temperature must be low enough that the packages and/or boards are not damaged. The peak temperature of the package depends on package thickness and volume and is classified in accordance with [Table 7](#) and [8](#)

Table 7. SnPb eutectic process (from J-STD-020D)

Package thickness (mm)	Package reflow temperature (°C)	
	Volume (mm ³)	
	< 350	≥ 350
< 2.5	235	220
≥ 2.5	220	220

Table 8. Lead-free process (from J-STD-020D)

Package thickness (mm)	Package reflow temperature (°C)		
	Volume (mm ³)		
	< 350	350 to 2000	> 2000
< 1.6	260	260	260
1.6 to 2.5	260	250	245
> 2.5	250	245	245

Moisture sensitivity precautions, as indicated on the packing, must be respected at all times.

Studies have shown that small packages reach higher temperatures during reflow soldering, see [Figure 11](#).

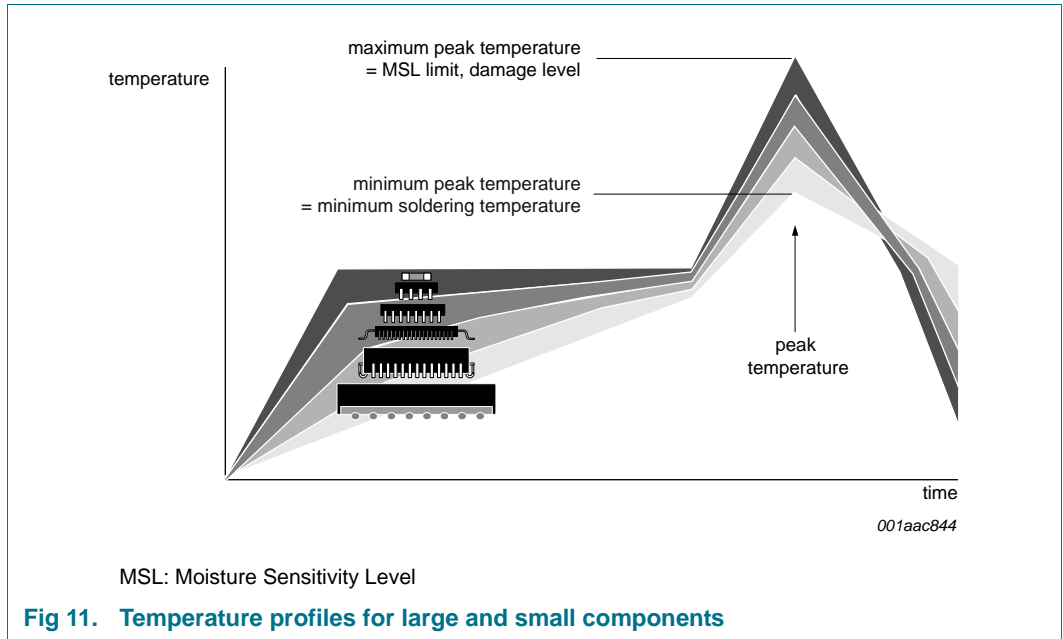

For further information on temperature profiles, refer to Application Note AN10365 “Surface mount reflow soldering description”.

15. Revision history

Table 9. Revision history

Document ID	Release date	Data sheet status	Change notice	Supersedes
TDA8579T v.4	20130923	Product data sheet	-	TDA8579 v.3
Modifications:	<ul style="list-style-type: none"> Security status changed from company confidential to company public. 			
TDA8579T v.3	20130606	Product data sheet	-	TDA8579 v.2
Modifications:	<ul style="list-style-type: none"> The format of this document has been redesigned to comply with the new identity guidelines of NXP Semiconductors. Legal texts have been adapted to the new company name where appropriate. 			
TDA8579 v.2	19951215	Product data sheet	-	TDA8579 v.1
TDA8579 v.1	19940125	Product data sheet	-	-

16. Legal information

16.1 Data sheet status

Document status ^{[1][2]}	Product status ^[3]	Definition
Objective [short] data sheet	Development	This document contains data from the objective specification for product development.
Preliminary [short] data sheet	Qualification	This document contains data from the preliminary specification.
Product [short] data sheet	Production	This document contains the product specification.

[1] Please consult the most recently issued document before initiating or completing a design.

[2] The term 'short data sheet' is explained in section "Definitions".

[3] The product status of device(s) described in this document may have changed since this document was published and may differ in case of multiple devices. The latest product status information is available on the Internet at URL <http://www.nxp.com>.

16.2 Definitions

Draft — The document is a draft version only. The content is still under internal review and subject to formal approval, which may result in modifications or additions. NXP Semiconductors does not give any representations or warranties as to the accuracy or completeness of information included herein and shall have no liability for the consequences of use of such information.

Short data sheet — A short data sheet is an extract from a full data sheet with the same product type number(s) and title. A short data sheet is intended for quick reference only and should not be relied upon to contain detailed and full information. For detailed and full information see the relevant full data sheet, which is available on request via the local NXP Semiconductors sales office. In case of any inconsistency or conflict with the short data sheet, the full data sheet shall prevail.

Product specification — The information and data provided in a Product data sheet shall define the specification of the product as agreed between NXP Semiconductors and its customer, unless NXP Semiconductors and customer have explicitly agreed otherwise in writing. In no event however, shall an agreement be valid in which the NXP Semiconductors product is deemed to offer functions and qualities beyond those described in the Product data sheet.

16.3 Disclaimers

Limited warranty and liability — Information in this document is believed to be accurate and reliable. However, NXP Semiconductors does not give any representations or warranties, expressed or implied, as to the accuracy or completeness of such information and shall have no liability for the consequences of use of such information. NXP Semiconductors takes no responsibility for the content in this document if provided by an information source outside of NXP Semiconductors.

In no event shall NXP Semiconductors be liable for any indirect, incidental, punitive, special or consequential damages (including - without limitation - lost profits, lost savings, business interruption, costs related to the removal or replacement of any products or rework charges) whether or not such damages are based on tort (including negligence), warranty, breach of contract or any other legal theory.

Notwithstanding any damages that customer might incur for any reason whatsoever, NXP Semiconductors' aggregate and cumulative liability towards customer for the products described herein shall be limited in accordance with the *Terms and conditions of commercial sale* of NXP Semiconductors.

Right to make changes — NXP Semiconductors reserves the right to make changes to information published in this document, including without limitation specifications and product descriptions, at any time and without notice. This document supersedes and replaces all information supplied prior to the publication hereof.

Suitability for use — NXP Semiconductors products are not designed, authorized or warranted to be suitable for use in life support, life-critical or safety-critical systems or equipment, nor in applications where failure or malfunction of an NXP Semiconductors product can reasonably be expected to result in personal injury, death or severe property or environmental damage. NXP Semiconductors and its suppliers accept no liability for inclusion and/or use of NXP Semiconductors products in such equipment or applications and therefore such inclusion and/or use is at the customer's own risk.

Applications — Applications that are described herein for any of these products are for illustrative purposes only. NXP Semiconductors makes no representation or warranty that such applications will be suitable for the specified use without further testing or modification.

Customers are responsible for the design and operation of their applications and products using NXP Semiconductors products, and NXP Semiconductors accepts no liability for any assistance with applications or customer product design. It is customer's sole responsibility to determine whether the NXP Semiconductors product is suitable and fit for the customer's applications and products planned, as well as for the planned application and use of customer's third party customer(s). Customers should provide appropriate design and operating safeguards to minimize the risks associated with their applications and products.

NXP Semiconductors does not accept any liability related to any default, damage, costs or problem which is based on any weakness or default in the customer's applications or products, or the application or use by customer's third party customer(s). Customer is responsible for doing all necessary testing for the customer's applications and products using NXP Semiconductors products in order to avoid a default of the applications and the products or of the application or use by customer's third party customer(s). NXP does not accept any liability in this respect.

Limiting values — Stress above one or more limiting values (as defined in the Absolute Maximum Ratings System of IEC 60134) will cause permanent damage to the device. Limiting values are stress ratings only and (proper) operation of the device at these or any other conditions above those given in the Recommended operating conditions section (if present) or the Characteristics sections of this document is not warranted. Constant or repeated exposure to limiting values will permanently and irreversibly affect the quality and reliability of the device.

Terms and conditions of commercial sale — NXP Semiconductors products are sold subject to the general terms and conditions of commercial sale, as published at <http://www.nxp.com/profile/terms>, unless otherwise agreed in a valid written individual agreement. In case an individual agreement is concluded only the terms and conditions of the respective agreement shall apply. NXP Semiconductors hereby expressly objects to applying the customer's general terms and conditions with regard to the purchase of NXP Semiconductors products by customer.

No offer to sell or license — Nothing in this document may be interpreted or construed as an offer to sell products that is open for acceptance or the grant, conveyance or implication of any license under any copyrights, patents or other industrial or intellectual property rights.

Export control — This document as well as the item(s) described herein may be subject to export control regulations. Export might require a prior authorization from competent authorities.

Non-automotive qualified products — Unless this data sheet expressly states that this specific NXP Semiconductors product is automotive qualified, the product is not suitable for automotive use. It is neither qualified nor tested in accordance with automotive testing or application requirements. NXP Semiconductors accepts no liability for inclusion and/or use of non-automotive qualified products in automotive equipment or applications.

In the event that customer uses the product for design-in and use in automotive applications to automotive specifications and standards, customer (a) shall use the product without NXP Semiconductors' warranty of the product for such automotive applications, use and specifications, and (b) whenever customer uses the product for automotive applications beyond NXP Semiconductors' specifications such use shall be solely at customer's own risk, and (c) customer fully indemnifies NXP Semiconductors for any

liability, damages or failed product claims resulting from customer design and use of the product for automotive applications beyond NXP Semiconductors' standard warranty and NXP Semiconductors' product specifications.

Quick reference data — The Quick reference data is an extract of the product data given in the Limiting values and Characteristics sections of this document, and as such is not complete, exhaustive or legally binding.

Translations — A non-English (translated) version of a document is for reference only. The English version shall prevail in case of any discrepancy between the translated and English versions.

16.4 Trademarks

Notice: All referenced brands, product names, service names and trademarks are the property of their respective owners.

17. Contact information

For more information, please visit: <http://www.nxp.com>

For sales office addresses, please send an email to: salesaddresses@nxp.com

18. Contents

1 **General description** 1

2 **Features and benefits** 1

3 **Quick reference data** 1

4 **Ordering information** 2

5 **Block diagram** 2

6 **Pinning information** 2

6.1 Pinning 2

6.2 Pin description 3

7 **Functional description** 3

8 **Limiting values** 4

9 **Thermal characteristics** 4

10 **Characteristics** 5

11 **Application information** 6

12 **Package outline** 10

13 **Handling information** 11

14 **Soldering of SMD packages** 11

14.1 Introduction to soldering 11

14.2 Wave and reflow soldering 11

14.3 Wave soldering 11

14.4 Reflow soldering 12

15 **Revision history** 13

16 **Legal information** 14

16.1 Data sheet status 14

16.2 Definitions 14

16.3 Disclaimers 14

16.4 Trademarks 15

17 **Contact information** 15

18 **Contents** 16

Please be aware that important notices concerning this document and the product(s) described herein, have been included in section 'Legal information'.

Looking for pricing, stock, or lifecycle information?

Click below to explore more details on WIN SOURCE:

- ⊖ [View TDA8579T/N1SJ on WIN SOURCE](#)
- ⊖ [NXP / Nexperia Information](#)

Optimize Your Supply Chain with WIN SOURCE Solutions

- ✓ Global Sourcing Solution
- ✓ Obsolete Management
- ✓ Cost Control Management
- ✓ Shortage Management
- ✓ Alternative Solution
- ✓ Excess Inventory Management