



**THE DATASHEET OF  
840S07BYILF**



## General Description

The 840S071 is a seven output LVCMOS/LVTTL Frequency Synthesizer accepting crystal or single-ended reference clock inputs. The 840S071 uses a 25MHz parallel resonant crystal to generate 33.33MHz – 166.67MHz clock signals, replacing solutions requiring multiple oscillator and fanout buffer solutions. The device supports output slew rate control with two slew select pins (SLEW[1:0]). The VCO operates at a frequency of 2GHz. The device has 3 output banks, output QAA with one 33.33MHz – 166.67MHz LVCMOS/LVTTL output, output QAB with one 125MHz LVCMOS/LVTTL output and Bank B with three 33.33MHz – 166.67MHz LVCMOS/LVTTL outputs.

Output QAA and Bank B have their own dedicated frequency select pins and can be independently set for the frequencies mentioned above. Designed for networking and industrial applications, the 840S071 can also drive the high-speed clock inputs of communication processors, DSPs, switches and bridges.

## Features

- Five single-ended LVCMOS/LVTTL outputs
- Two REF\_OUT LVCMOS/LVTTL clock outputs
- Selectable crystal oscillator interface, 25MHz, 18pF parallel resonant crystal or LVCMOS/LVTTL single-ended reference input
- Supports the following output frequencies:  
**Output QAA/Bank B:** 33.33MHz, 50MHz, 66.67MHz, 83.33MHz, 100MHz, 125MHz, 133.33MHz and 166.67MHz  
**Output QAB:** 125MHz
- VCO frequency: 2GHz
- Slew rate control
- Voltage supply modes:  
 Core/Output  
 3.3V/3.3V  
 3.3V/2.5V
- -40°C to 85°C ambient operating temperature
- Available in lead-free (RoHS 6) package

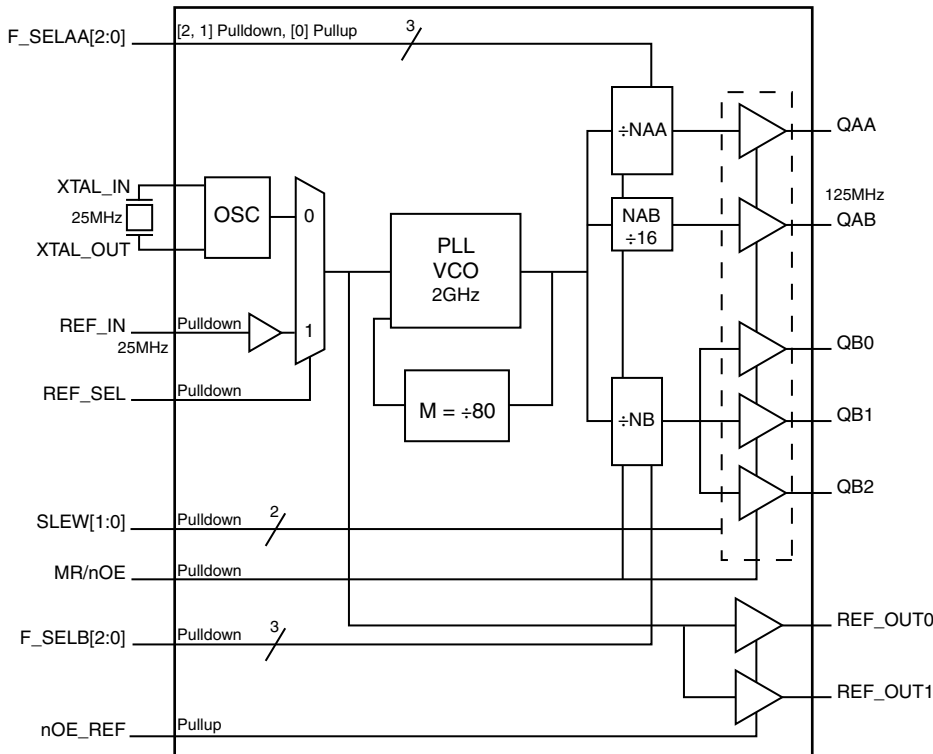

## Pin Assignment

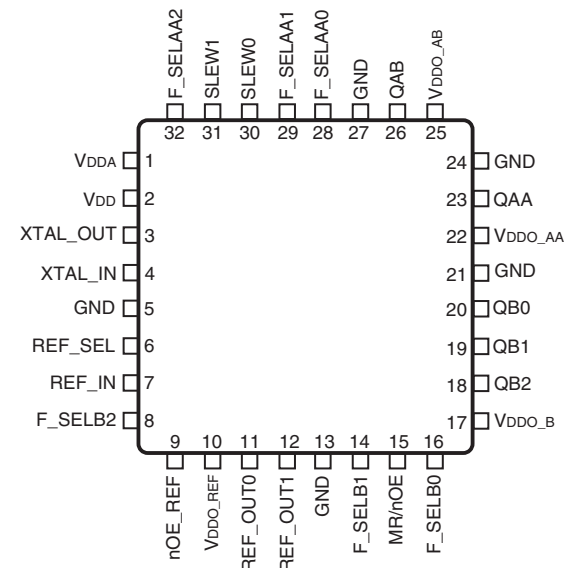

### 840S071

32-Lead TQFP, E-Pad  
 7mm x 7mm x 1mm package body  
 Y Package  
 Top View

**Table 1. Pin Descriptions**

Number	Name	Type		Description
1	V <sub>DDA</sub>	Power		Analog supply pin.
2	V <sub>DD</sub>	Power		Core supply pin.
3, 4	XTAL_OUT, XTAL_IN	Input		Crystal oscillator interface. XTAL_IN is the input. XTAL_OUT is the output.
5, 13, 21, 24, 27	GND	Power		Power supply ground.
6	REF_SEL	Input	Pulldown	Reference select pin. When HIGH selects REF_IN. When LOW, selects crystal. See Table 3D. LVCMOS/LVTTL interface levels.
7	REF_IN	Input	Pulldown	Single-ended reference clock input. Table 3B. LVCMOS/LVTTL interface levels.
8, 14, 16	F_SELB2, F_SELB1, F_SELB0	Input	Pulldown	Frequency select pins for Bank B outputs. See Table 3C. LVCMOS/LVTTL interface levels.
9	nOE_REF	Input	Pullup	Active low REF_OUT enable/disable pin. See Table 3F. LVCMOS/LVTTL interface levels.
10	V <sub>DDO_REF</sub>	Power		Output supply pin for REF_OUTx clock outputs.
11, 12	REF_OUT0, REF_OUT1	Output		Single-ended reference clock outputs. LVCMOS/LVTTL interface levels.
15	MR/nOE	Input	Pulldown	Active HIGH Master Reset. Active LOW output enable. When logic HIGH, the internal dividers are reset and the outputs are in high impedance (HI-Z). When logic LOW, the internal dividers and the outputs are enabled. See Table 3E. LVCMOS/LVTTL interface levels.
17	V <sub>DDO_B</sub>	Power		Output supply pin for QBx outputs.
18, 19, 20	QB2, QB1, QB0	Output		Single-ended Bank QBx clock outputs. LVCMOS/ LVTTL interface levels.
22	V <sub>DDO_AA</sub>	Power		Output supply pin for QAA output.
23	QAA	Output		Single-ended QAA clock output. LVCMOS/LVTTL interface levels.
25	V <sub>DDO_AB</sub>	Power		Output supply pin for QAB output.
26	QAB	Output		Single-ended QAB clock output. LVCMOS/LVTTL interface levels.
28	F_SELAA0	Input	Pullup	Frequency select pin for QAA output. See Table 3A. LVCMOS/LVTTL interface levels.
29, 32	F_SELAA1, F_SELAA2	Input	Pulldown	Frequency select pins for QAA output. See Table 3A. LVCMOS/LVTTL interface levels.
30, 31	SLEW0, SLEW1	Input	Pulldown	Slew rate select pins for LVCMOS/LVTTL clock output. LVCMOS/LVTTL interface levels.

NOTE: *Pullup and Pulldown* refer to internal input resistors. See Table 2, *Pin Characteristics*, for typical values.

**Table 2. Pin Characteristics**

Symbol	Parameter	Test Conditions	Minimum	Typical	Maximum	Units
$C_{IN}$	Input Capacitance			2		pF
$C_{PD}$	Power Dissipation Capacitance	SLEW[1:0] = 00 $V_{DD}, V_{DDO\_REF}, V_{DDO\_AA}, V_{DDO\_AB}, V_{DDO\_B} = 3.465V$		4		pF
		SLEW[1:0] = 11 $V_{DD}, V_{DDO\_REF}, V_{DDO\_AA}, V_{DDO\_AB}, V_{DDO\_B} = 3.465V$		10		pF
		SLEW[1:0] = 00, $V_{DD} = 3.465V$ , $V_{DDO\_REF}, V_{DDO\_AA}, V_{DDO\_AB}, V_{DDO\_B} = 2.625V$		2.65		pF
		SLEW[1:0] = 11, $V_{DD} = 3.465V$ , $V_{DDO\_REF}, V_{DDO\_AA}, V_{DDO\_AB}, V_{DDO\_B} = 2.625V$		3		pF
$R_{PULLUP}$	Input Pullup Resistor			51		k $\Omega$
$R_{PULLDOWN}$	Input Pulldown Resistor			51		k $\Omega$
$R_{OUT}$	Output Impedance	QAA, QAB, QBx $V_{DDO\_AA}, V_{DDO\_AB}, V_{DDO\_B} = 3.3V$		26		$\Omega$
		$V_{DDO\_AA}, V_{DDO\_AB}, V_{DDO\_B} = 2.5V$		28		$\Omega$
		REF_OUTx $V_{DDO\_REF} = 3.3V$		35		$\Omega$
		$V_{DDO\_REF} = 2.5V$		34		$\Omega$

## Function Tables

**Table 3A. Output QAA Frequency Select Function Table**

Inputs				Output Frequencies
F_SELAA2	F_SELAA1	F_SELAA0	NAA Divider Value	QAA (MHz)
L	L	L	60	33.33
L	L	H	40	50 (default)
L	H	L	30	66.67
L	H	H	24	83.33
H	L	L	20	100
H	L	H	16	125
H	H	L	15	133.33
H	H	H	12	166.67

NOTE: Using 25MHz reference.

**Table 3B. Output QAB Frequency Select Function Table**

Inputs			Output Frequency
XTAL_IN, REF_IN (MHz)	M Divider Value	NAB Divider Value	QAB (MHz)
25	80	16	125

**Table 3C. Bank QB Frequency Select Function Table**

Inputs				Output Frequencies
F_SEL B2	F_SEL B1	F_SEL B0	NB Divider Value	QB[0:2] (MHz)
L	L	L	60	33.33 (default)
L	L	H	40	50
L	H	L	30	66.67
L	H	H	24	83.33
H	L	L	20	100
H	L	H	16	125
H	H	L	15	133.33
H	H	H	12	166.67

NOTE: Using 25MHz reference.

**Table 3D. REF\_SEL Function Table**

Input	
REF_SEL	Input Reference
0 (default)	XTAL_IN
1	REF_IN

**Table 3E. MR/nOE Function Table**

Input	
MR/nOE	Function
0 (default)	Output Enabled
1	Device reset, outputs disabled (LOW)

NOTE: The device requires a reset signal after power-up to function properly.

**Table 3F. nOE\_REF Function Table**

Input	
nOE_REF	Function
0	REF_OUT [1:0] enabled
1 (default)	REF_OUT [1:0] disabled (LOW)

## Absolute Maximum Ratings

NOTE: Stresses beyond those listed under *Absolute Maximum Ratings* may cause permanent damage to the device. These ratings are stress specifications only. Functional operation of product at these conditions or any conditions beyond those listed in the *DC Characteristics* or *AC Characteristics* is not implied. Exposure to absolute maximum rating conditions for extended periods may affect product reliability.

Item	Rating
Supply Voltage, $V_{DD}$	4.6V
Inputs, $V_I$ XTAL_IN Other Inputs	0V to $V_{DD}$ -0.5V to $V_{DD} + 0.5V$
Outputs, $V_O$	-0.5V to $V_{DD} + 0.5V$
Package Thermal Impedance, $\theta_{JA}$	36.2°C/W (0 mps)
Storage Temperature, $T_{STG}$	-65°C to 150°C

## DC Electrical Characteristics

**Table 4A. Power Supply DC Characteristics,  $V_{DD} = V_{DDO\_REF} = V_{DDO\_AA} = V_{DDO\_AB} = V_{DDO\_B} = 3.3V \pm 5\%$ ,  $T_A = -40^\circ C$  to  $85^\circ C$**

Symbol	Parameter	Test Conditions	Minimum	Typical	Maximum	Units
$V_{DD}$	Core Supply Voltage		3.135	3.3	3.465	V
$V_{DDA}$	Analog Supply Voltage		$V_{DD} - 0.23$	3.3	$V_{DD}$	V
$V_{DDO\_X}$	Output Supply Voltage		3.135	3.3	3.465	V
$I_{DD}$	Power Supply Current	SLEW[1:0] = 11, QAA = QB[0:2] = 166.67MHz, QAB = 125MHz, REF_OUT[0:1] = 25MHz, Outputs Not Loaded			180	mA
$I_{DDA}$	Analog Supply Current				23	mA
$I_{DDO\_X}$	Output Supply Current				71	mA

NOTE:  $V_{DDO\_X}$  denotes  $V_{DDO\_AA}$ ,  $V_{DDO\_AB}$ ,  $V_{DDO\_B}$ ,  $V_{DDO\_REF}$ .

NOTE:  $I_{DDO\_X}$  denotes  $I_{DDO\_AA} + I_{DDO\_AB} + I_{DDO\_B} + I_{DDO\_REF}$ .

**Table 4B. Power Supply DC Characteristics,  $V_{DD} = 3.3V \pm 5\%$ ,  $V_{DDO\_REF} = V_{DDO\_AA} = V_{DDO\_AB} = V_{DDO\_B} = 2.5V \pm 5\%$ ,  $T_A = -40^\circ C$  to  $85^\circ C$**

Symbol	Parameter	Test Conditions	Minimum	Typical	Maximum	Units
$V_{DD}$	Core Supply Voltage		3.135	3.3	3.465	V
$V_{DDA}$	Analog Supply Voltage		$V_{DD} - 0.23$	3.3	$V_{DD}$	V
$V_{DDO\_X}$	Output Supply Voltage		2.375	2.5	2.625	V
$I_{DD}$	Power Supply Current	SLEW[1:0] = 11, QAA = QB[0:2] = 166.67MHz, QAB = 125MHz, REF_OUT[0:1] = 25MHz, Outputs Not Loaded			180	mA
$I_{DDA}$	Analog Supply Current				23	mA
$I_{DDO\_X}$	Output Supply Current				21	mA

NOTE:  $V_{DDO\_X}$  denotes  $V_{DDO\_AA}$ ,  $V_{DDO\_AB}$ ,  $V_{DDO\_B}$ ,  $V_{DDO\_REF}$ .

NOTE:  $I_{DDO\_X}$  denotes  $I_{DDO\_AA} + I_{DDO\_AB} + I_{DDO\_B} + I_{DDO\_REF}$ .

**Table 4C. LVC MOS/LVTTL DC Characteristics,  $V_{DD} = 3.3V \pm 5\%$ ,  $V_{DDO} = 3.3V \pm 5\%$  or  $2.5V \pm 5\%$ ,  $T_A = -40^\circ C$  to  $85^\circ C$** 

Symbol	Parameter	Test Conditions	Minimum	Typical	Maximum	Units
$V_{IH}$	Input High Voltage	$V_{DD} = 3.465V$	2.2		$V_{DD} + 0.3$	V
$V_{IL}$	Input Low Voltage	$V_{DD} = 3.465V$	-0.3		0.8	V
$I_{IH}$	Input High Current	nOE_REF, F_SELAA0	$V_{DD} = V_{IN} = 3.465V$		10	$\mu A$
		F_SELB[2:0], F_SELAA[1:2], REF_IN, REF_SEL, SLEW[1:0], MR/nOE	$V_{DD} = V_{IN} = 3.465V$		150	$\mu A$
$I_{IL}$	Input Low Current	nOE_REF, F_SELAA0	$V_{DD} = 3.465V, V_{IN} = 0V$	-150		$\mu A$
		F_SELB[2:0], F_SELAA[1:2], REF_IN, REF_SEL, SLEW[1:0], MR/nOE	$V_{DD} = 3.465V, V_{IN} = 0V$	-10		$\mu A$
$V_{OH}$	Output High Voltage; NOTE 1	QAA, QB[0:2], REF_OUT[0:1]	SLEW[1:0] = 00, QAA, QB[0:2] = 33.33MHz, REF_OUT[0:1] = 25MHz	2.45		V
			1.8		V	
$V_{OL}$	Output Low Voltage; NOTE 1	QAA, QB[0:2], REF_OUT[0:1]	SLEW[1:0] = 00, QAA, QB[0:2] = 33.33MHz, REF_OUT[0:1] = 25MHz		0.8	V
					0.65	V

 NOTE:  $V_{DDO\_X}$  denotes  $V_{DDO\_AA}$ ,  $V_{DDO\_AB}$ ,  $V_{DDO\_B}$ ,  $V_{DDO\_REF}$ .

 NOTE 1: Outputs terminated with  $50\Omega$  to  $V_{DDO\_X}/2$ . See Parameter Measurement Information Section, *Load Test Circuit diagrams*.

**Table 5. Crystal Characteristics**

Parameter	Test Conditions	Minimum	Typical	Maximum	Units
Mode of Oscillation		Fundamental			
Frequency			25		MHz
Equivalent Series Resistance (ESR)				50	$\Omega$
Shunt Capacitance				7	pF

NOTE: Characterized using an 18pF parallel resonant crystal.

## AC Electrical Characteristics

**Table 6A. AC Characteristics,  $V_{DD} = V_{DDO\_REF} = V_{DDO\_AA} = V_{DDO\_AB} = V_{DDO\_B} = 3.3V \pm 5\%$ ,  $T_A = -40^{\circ}C$  to  $85^{\circ}C$** 

Symbol	Parameter	Test Conditions	Minimum	Typical	Maximum	Units
$f_{OUT}$	Output Frequency	QAB		125		MHz
		QAA, QB[0:2]	33.33		166.67	MHz
$t_{sk(o)}$	Output Skew; NOTE 1, 2	$f_{OUT} = 125MHz$ ; SLEW[1:0] = 00			485	ps
$t_{sk(b)}$	Bank Skew; NOTE 2, 3	QB[0:2] $f_{OUT} = 125MHz$ ; SLEW[1:0] = 00			110	ps
$t_{jit(per)}$	Period Jitter, RMS; NOTE 4	$f_{OUT} = 125MHz$ ; SLEW[1:0] = 00			7	ps
$t_{jit(cc)}$	Cycle-to-Cycle Jitter; NOTE 2	$f_{OUT} = 125MHz$ ; SLEW[1:0] = 00			90	ps
$t_{SLEW}$	Slew Rate, Single-ended Output Clock; NOTE 5	QAA	SLEW[1:0] = 00, Rise/Fall Time: 20% to 80%	1.93	3.0	V/ns
		QAB		2.84	4.75	V/ns
		QB[0:2]		2.59	4.25	V/ns
		QAA	SLEW[1:0] = 01, Rise/Fall Time: 20% to 80%	1.76	2.75	V/ns
		QAB		2.45	4.25	V/ns
		QB[0:2]		2.23	3.75	V/ns
		QAA	SLEW[1:0] = 10, Rise/Fall Time: 20% to 80%	1.58	2.50	V/ns
		QAB		1.88	3.0	V/ns
		QB[0:2]		1.80	2.95	V/ns
		QAA	SLEW[1:0] = 11, Rise/Fall Time: 20% to 80%	0.98	1.65	V/ns
		QAB		1.03	1.75	V/ns
		QB[0:2]		1.01	1.75	V/ns
$t_{LOCK}$	PLL Lock Time	SLEW[1:0] = 00			20	ms
odc	Output Duty Cycle	$f_{OUT} \leq 125MHz$ ; SLEW[1:0] = 00	47		53	%
		$f_{OUT} > 125MHz$ ; SLEW[1:0] = 00	45		55	%

NOTE: Electrical parameters are guaranteed over the specified ambient operating temperature range, which is established when device is mounted in a test socket with maintained transverse airflow greater than 500 lfm. Device will meet specifications after thermal equilibrium has been reached under these conditions.

NOTE 1: Defined as skew between outputs at the same supply voltage and with equal load conditions. Measured at  $V_{DDO\_X}/2$ .

NOTE 2: This parameter is defined in accordance with JEDEC Standard 65.

NOTE 3: Defined as skew within a bank of outputs at the same supply voltage and with equal load conditions.

NOTE 4: Jitter performance using XTAL inputs.

NOTE 5: A slew rate of 2V/ns or greater should be selected for output frequencies of 100MHz and higher.

**Table 6B. AC Characteristics,  $V_{DD} = 3.3V \pm 5\%$ ,  $V_{DDO\_REF} = V_{DDO\_AA} = V_{DDO\_AB} = V_{DDO\_B} = 2.5V \pm 5\%$ ,  $T_A = -40^{\circ}C$  to  $85^{\circ}C$** 

Symbol	Parameter	Test Conditions	Minimum	Typical	Maximum	Units
$f_{OUT}$	Output Frequency	QAB		125		MHz
		QAA, QB[0:2]	33.33		166.67	MHz
$t_{sk(o)}$	Output Skew; NOTE 1, 2	$f_{OUT} = 125MHz$ ; SLEW[1:0] = 00			435	ps
$t_{sk(b)}$	Bank Skew; NOTE 2, 3	QB[0:2] $f_{OUT} = 125MHz$ ; SLEW[1:0] = 00			115	ps
$t_{jit(per)}$	Period Jitter, RMS; NOTE 4	$f_{OUT} = 125MHz$ ; SLEW[1:0] = 00			12	ps
$t_{jit(cc)}$	Cycle-to-Cycle Jitter; NOTE 2	$f_{OUT} = 125MHz$ ; SLEW[1:0] = 00			96	ps
$t_{SLEW}$	Slew Rate, Single-ended Output Clocks; NOTE 5	QAA	SLEW[1:0] = 00, Rise/Fall Time: 20% to 80%	1.36	2.15	V/ns
		QAB		1.89	3.25	V/ns
		QB[0:2]		1.81	2.85	V/ns
		QAA	SLEW[1:0] = 01, Rise/Fall Time: 20% to 80%	1.12	1.85	V/ns
		QAB		1.43	2.50	V/ns
		QB[0:2]		1.44	2.50	V/ns
		QAA	SLEW[1:0] = 10, Rise/Fall Time: 20% to 80%	0.88	1.55	V/ns
		QAB		1.06	1.85	V/ns
		QB[0:2]		1.03	1.85	V/ns
		QAA	SLEW[1:0] = 11, Rise/Fall Time: 20% to 80%	0.59	1.15	V/ns
		QAB		0.66	1.15	V/ns
		QB[0:2]		0.61	1.15	V/ns
$t_{LOCK}$	PLL Lock Time	SLEW[1:0] = 00			25	ms
odc	Output Duty Cycle	$f_{OUT} \leq 125MHz$ ; SLEW[1:0] = 00	45		55	%
		$f_{OUT} > 125MHz$ ; SLEW[1:0] = 00	43		57	%

NOTE: Electrical parameters are guaranteed over the specified ambient operating temperature range, which is established when device is mounted in a test socket with maintained transverse airflow greater than 500 lpm. Device will meet specifications after thermal equilibrium has been reached under these conditions.

NOTE 1: Defined as skew between outputs at the same supply voltage and with equal load conditions. Measured at  $V_{DDO\_X}/2$ .

NOTE 2: This parameter is defined in accordance with JEDEC Standard 65.

NOTE 3: Defined as skew within a bank of outputs at the same supply voltage and with equal load conditions.

NOTE 4: Jitter performance using XTAL inputs.

NOTE 5: A slew rate of 2V/ns or greater should be selected for output frequencies of 100MHz and higher.

### Parameter Measurement Information

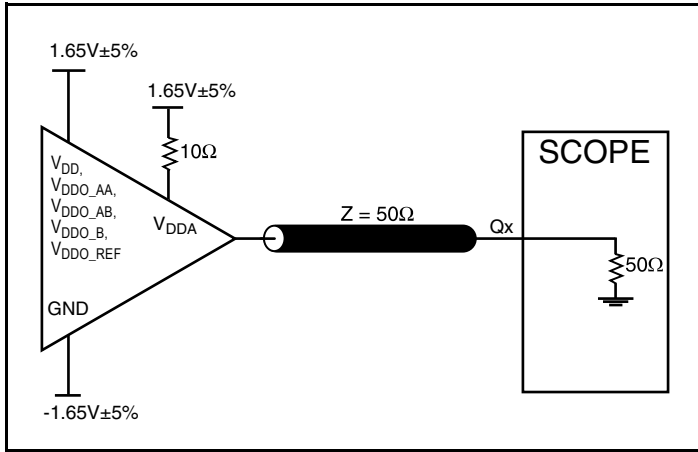

3.3V Core/3.3V LVCMOS Output Load AC Test Circuit

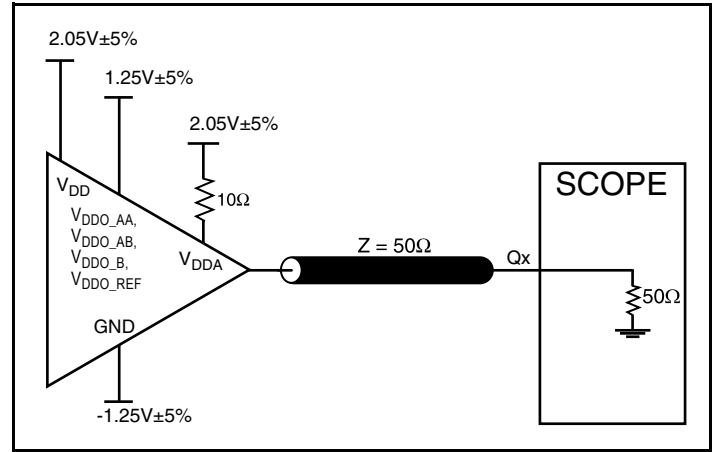

3.3V Core/2.5V LVCMOS Output Load AC Test Circuit

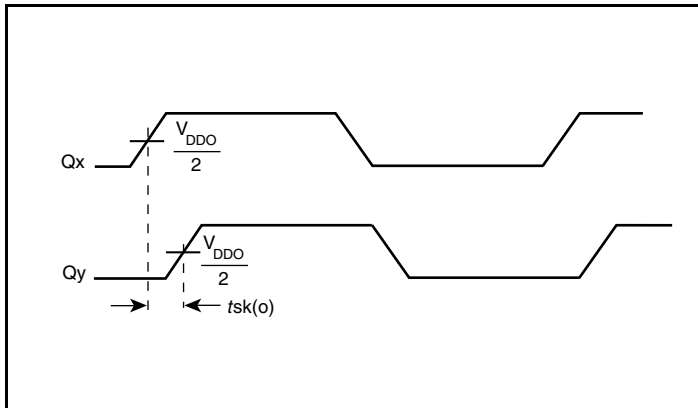

Output Skew

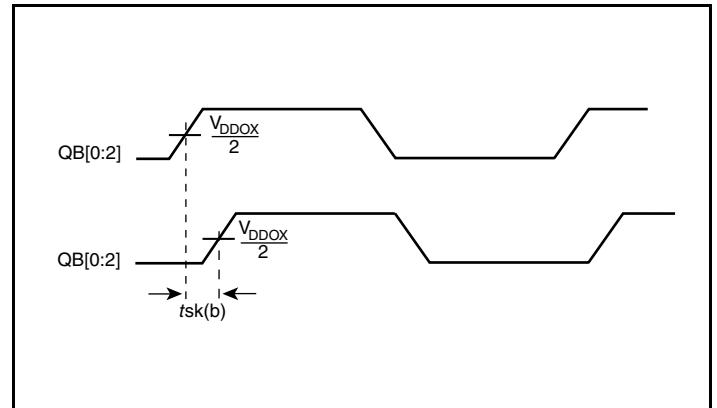

Bank Skew

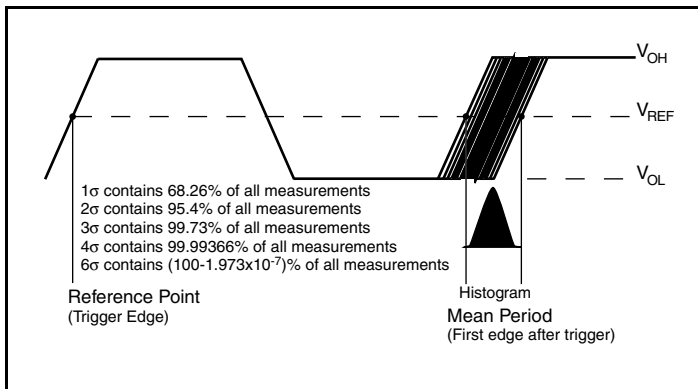

RMS Period Jitter

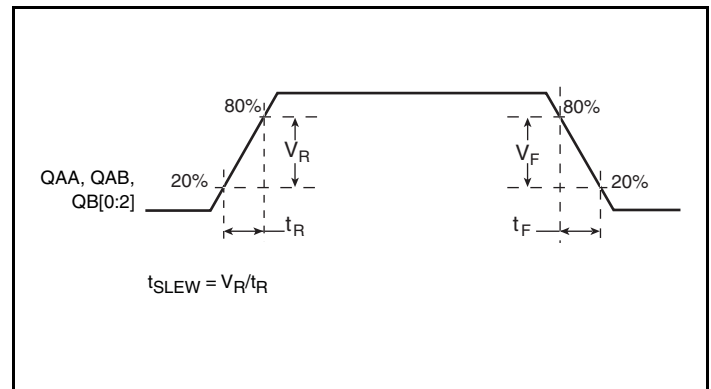

Output Slew Rate

## Parameter Measurement Information, continued

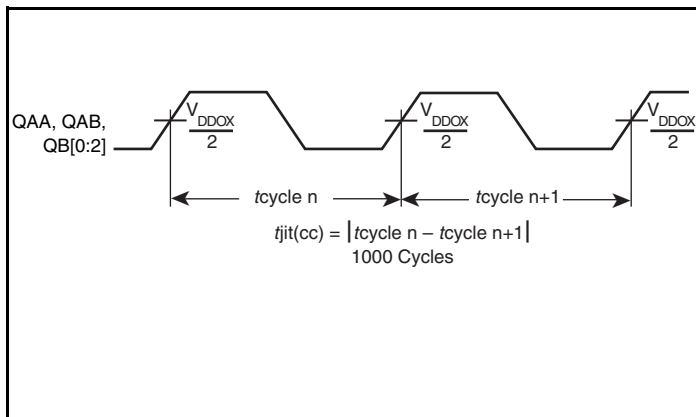

**Cycle-to-Cycle Jitter**

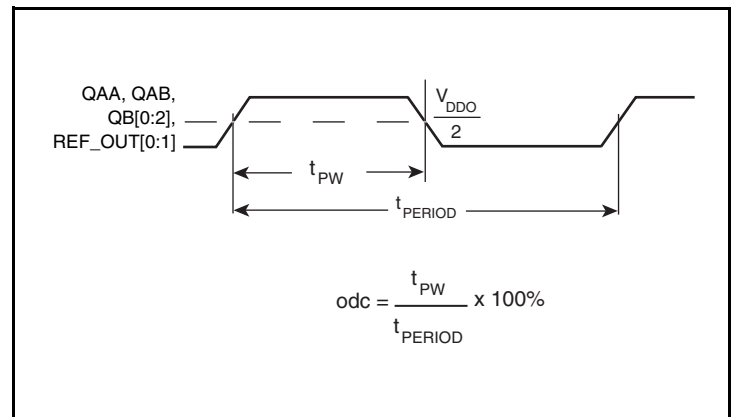

**Output Duty Cycle/Pulse Width/Period**

## Applications Information

### Recommendations for Unused Input and Output Pins

#### Inputs:

##### LVC MOS Control Pins

All control pins have internal pullups or pulldowns; additional resistance is not required but can be added for additional protection. A 1kΩ resistor can be used.

##### Crystal Inputs

For applications not requiring the use of the crystal oscillator input, both XTAL\_IN and XTAL\_OUT can be left floating. Though not required, but for additional protection, a 1kΩ resistor can be tied from XTAL\_IN to ground.

##### REF\_IN Input

For applications not requiring the use of the reference clock, it can be left floating. Though not required, but for additional protection, a 1kΩ resistor can be tied from the REF\_IN to ground.

#### Outputs:

##### LVC MOS Outputs

All unused LVC MOS output can be left floating. There should be no trace attached.

## Power Supply Filtering Technique

As in any high speed analog circuitry, the power supply pins are vulnerable to random noise. To achieve optimum jitter performance, power supply isolation is required. The 840S071 provides separate power supplies to isolate any high switching noise from the outputs to the internal PLL.  $V_{DD}$ ,  $V_{DDA}$  and  $V_{DDO\_X}$  should be individually connected to the power supply plane through vias, and  $0.01\mu\text{F}$  bypass capacitors should be used for each pin. *Figure 1* illustrates this for a generic  $V_{DD}$  pin and also shows that  $V_{DDA}$  requires that an additional  $10\Omega$  resistor along with a  $10\mu\text{F}$  bypass capacitor be connected to the  $V_{DDA}$  pin.

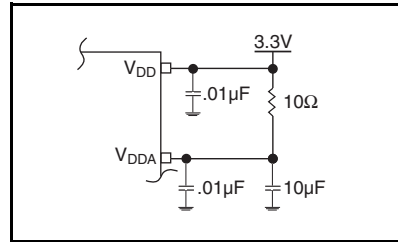

**Figure 1. Power Supply Filtering**

## EPAD Thermal Release Path

In order to maximize both the removal of heat from the package and the electrical performance, a land pattern must be incorporated on the Printed Circuit Board (PCB) within the footprint of the package corresponding to the exposed metal pad or exposed heat slug on the package, as shown in *Figure 2*. The solderable area on the PCB, as defined by the solder mask, should be at least the same size/shape as the exposed pad/slug area on the package to maximize the thermal/electrical performance. Sufficient clearance should be designed on the PCB between the outer edges of the land pattern and the inner edges of pad pattern for the leads to avoid any shorts.

While the land pattern on the PCB provides a means of heat transfer and electrical grounding from the package to the board through a solder joint, thermal vias are necessary to effectively conduct from the surface of the PCB to the ground plane(s). The land pattern must be connected to ground through these vias. The vias act as “heat pipes”. The number of vias (i.e. “heat pipes”) are application specific

and dependent upon the package power dissipation as well as electrical conductivity requirements. Thus, thermal and electrical analysis and/or testing are recommended to determine the minimum number needed. Maximum thermal and electrical performance is achieved when an array of vias is incorporated in the land pattern. It is recommended to use as many vias connected to ground as possible. It is also recommended that the via diameter should be 12 to 13mils (0.30 to 0.33mm) with 1oz copper via barrel plating. This is desirable to avoid any solder wicking inside the via during the soldering process which may result in voids in solder between the exposed pad/slug and the thermal land. Precautions should be taken to eliminate any solder voids between the exposed heat slug and the land pattern. Note: These recommendations are to be used as a guideline only. For further information, refer to the Application Note on the *Surface Mount Assembly* of Amkor’s Thermally/Electrically Enhance Leadframe Base Package, Amkor Technology.

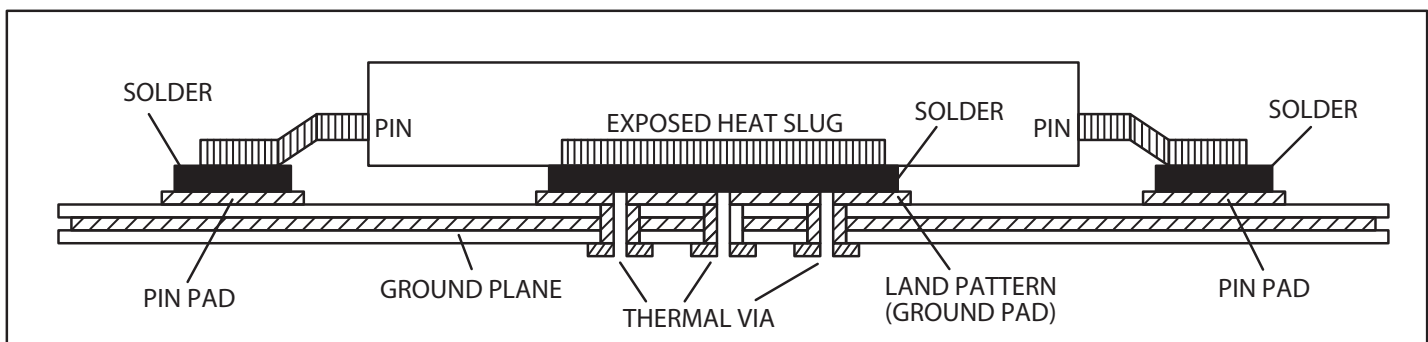

**Figure 2. Assembly for Exposed Pad Thermal Release Path - Side View (drawing not to scale)**

## Crystal Input Interface

The 840S071 has been characterized with 18pF parallel resonant crystals. The capacitor values shown in *Figure 3* below were determined using a 25MHz, 18pF parallel resonant crystal and were chosen to minimize the ppm error.

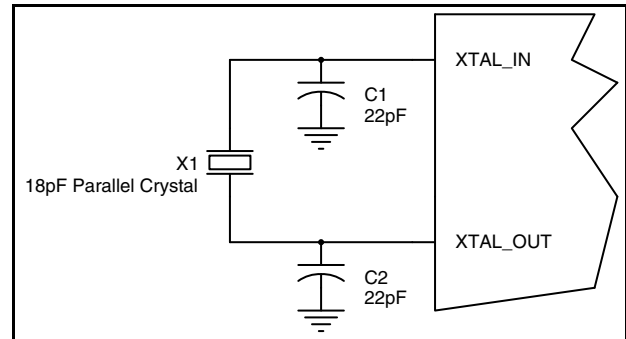
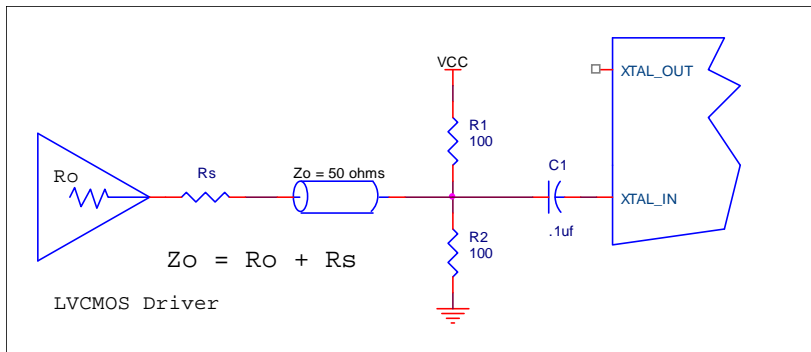

**Figure 3. Crystal Input Interface**

## Overdriving the XTAL Interface

The XTAL\_IN input can accept a single-ended LVCMOS signal through an AC coupling capacitor. A general interface diagram is shown in *Figure 4A*. The XTAL\_OUT pin can be left floating. The maximum amplitude of the input signal should not exceed 2V and the input edge rate can be as slow as 10ns. This configuration requires that the output impedance of the driver ( $R_o$ ) plus the series resistance ( $R_s$ ) equals the transmission line impedance. In addition,

matched termination at the crystal input will attenuate the signal in half. This can be done in one of two ways. First,  $R_1$  and  $R_2$  in parallel should equal the transmission line impedance. For most 50 $\Omega$  applications,  $R_1$  and  $R_2$  can be 100 $\Omega$ . This can also be accomplished by removing  $R_1$  and making  $R_2$  50 $\Omega$ . By overdriving the crystal oscillator, the device will be functional, but note, the device performance is guaranteed by using a quartz crystal.



**Figure 4A. General Diagram for LVCMOS Driver to XTAL Input Interface**

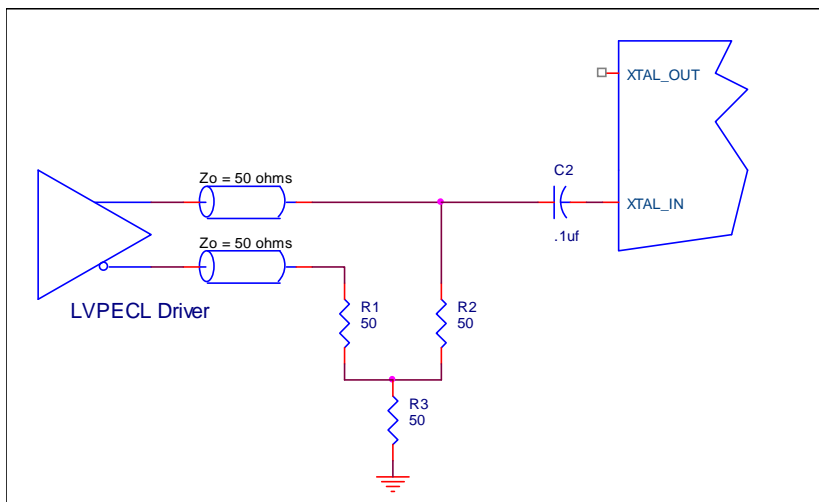

**Figure 4B. General Diagram for LVPECL Driver to XTAL Input Interface**

### Schematic Example

Figure 5 shows an example of the 840S071 application schematic. In this example, the device is operated at  $V_{DD} = V_{DDO\_AA} = V_{CCO\_AB} = V_{CCO\_B} = V_{CCO\_REF} = 3.3V$ . The 18pF parallel resonant 25MHz crystal is used. The  $C1 = 22pF$  and  $C2 = 22pF$  are recommended for frequency accuracy. For different board layouts, the  $C1$  and  $C2$  may

be slightly adjusted for optimizing frequency accuracy. Two examples of LVCMOS termination are shown in this schematic. The decoupling capacitors should be located as close as possible to the power pin.

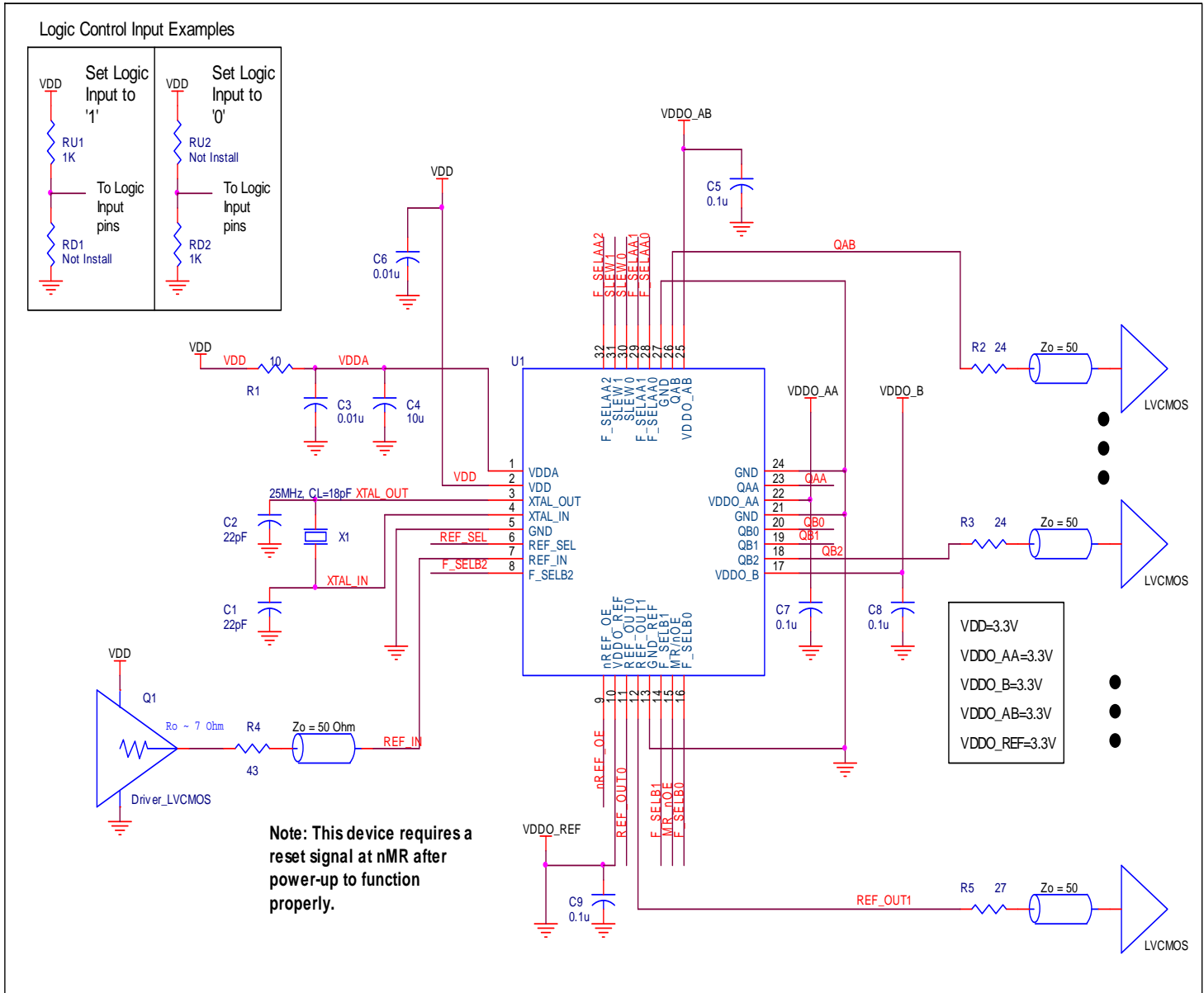

Figure 5. 840S071 Schematic Layout

## Power Considerations

This section provides information on power dissipation and junction temperature for the 840S07I. Equations and example calculations are also provided.

### 1. Power Dissipation.

The total power dissipation for the 840S07I is the sum of the core power plus the analog power plus the power dissipation in the load(s). The following is the power dissipation for  $V_{DD} = 3.3V + 5\% = 3.465V$ , which gives worst case results.

The maximum current at 85°C is as follows:

$$I_{DD\_MAX} = 168.5mA$$

$$I_{DDA\_MAX} = 20.96mA$$

$$I_{DDO\_MAX} = 74.11mA$$

### Core Output Power Dissipation

- Power (core)<sub>MAX</sub> =  $V_{DD\_MAX} * (I_{DD} + I_{DDA}) = 3.465V * (168.5mA + 20.96mA) = \mathbf{656.51mW}$
- Power (output)<sub>MAX</sub> =  $V_{DDO\_MAX} * I_{DDO} = 3.465V * 74.11mA = \mathbf{256.80mW}$

### LVC MOS Output Power Dissipation

- Output Impedance  $R_{OUT}$  Power Dissipation due to Loading 50Ω to  $V_{DD}/2$   
Output Current  $I_{OUT} = V_{DD\_MAX} / [2 * (50\Omega + R_{OUT})] = 3.465V / [2 * (50\Omega + 35\Omega)] = \mathbf{20.38mA}$
- Power Dissipation on the  $R_{OUT}$  per LVC MOS output  
Power ( $R_{OUT}$ ) =  $R_{OUT} * (I_{OUT})^2 = 35\Omega * (20.38mA)^2 = \mathbf{14.54mW \text{ per output}}$
- Total Power Dissipation on the  $R_{OUT}$   
**Total Power ( $R_{OUT}$ ) =  $14.54mW * 7 = \mathbf{101.8mW}$**
- Dynamic Power Dissipation at 25MHz  
Power (25MHz) =  $C_{PD} * \text{Frequency} * (V_{DDO})^2 = 10pF * 25MHz * (3.465V)^2 = \mathbf{3mW \text{ per output}}$   
**Total Power (25MHz) =  $3mW * 2 = \mathbf{6mW}$**
- Dynamic Power Dissipation at 166.67MHz  
Power (166.67MHz) =  $C_{PD} * \text{Frequency} * (V_{DDO})^2 = 10pF * 166.67MHz * (3.465V)^2 = \mathbf{20mW \text{ per output}}$   
**Total Power (166.67MHz) =  $20mW * 5 = \mathbf{100.1mW}$**

### Total Power Dissipation

- Total Power**  
= Power (core) + Power (output) + Total Power (25MHz) + Total Power (166.67MHz)  
=  $656.51mW + 256.80mW + 101.8mW + 6.0mW + 100.1mW$   
= **1121.15mW**

## 2. Junction Temperature.

Junction temperature,  $T_j$ , is the temperature at the junction of the bond wire and bond pad, and directly affects the reliability of the device. The maximum recommended junction temperature is 125°C. Limiting the internal transistor junction temperature,  $T_j$ , to 125°C ensures that the bond wire and bond pad temperature remains below 125°C.

The equation for  $T_j$  is as follows:  $T_j = \theta_{JA} * Pd_{total} + T_A$

$T_j$  = Junction Temperature

$\theta_{JA}$  = Junction-to-Ambient Thermal Resistance

$Pd_{total}$  = Total Device Power Dissipation (example calculation is in section 1 above)

$T_A$  = Ambient Temperature

In order to calculate junction temperature, the appropriate junction-to-ambient thermal resistance  $\theta_{JA}$  must be used. Assuming a moderate air flow of 1 meter per second and a multi-layer board, the appropriate value is 30.6°C/W per Table 7 below.

Therefore,  $T_j$  for an ambient temperature of 85°C with all outputs switching is:

$$85^\circ\text{C} + 1.121\text{W} * 30.6^\circ\text{C/W} = 119.3^\circ\text{C}. \text{ This is below the limit of } 125^\circ\text{C}.$$

This calculation is only an example.  $T_j$  will obviously vary depending on the number of loaded outputs, supply voltage, air flow and the type of board (multi-layer).

**Table 7. Thermal Resistance  $\theta_{JA}$  for 32 Lead TQFP, E-Pad, Forced Convection**

$\theta_{JA}$ by Velocity			
Meters per Second	0	1	2.5
Multi-Layer PCB, JEDEC Standard Test Boards	36.2°C/W	30.6°C/W	29.2°C/W

## Reliability Information

**Table 8.  $\theta_{JA}$  vs. Air Flow Table for a 32 Lead TQFP, E-Pad**

$\theta_{JA}$ vs. Air Flow			
Meters per Second	0	1	2.5
Multi-Layer PCB, JEDEC Standard Test Boards	36.2°C/W	30.6°C/W	29.2°C/W

## Transistor Count

The transistor count for 840S07I is: 2349

# Package Outline and Package Dimensions

## Package Outline - G Suffix for 32 Lead TQFP, E-Pad

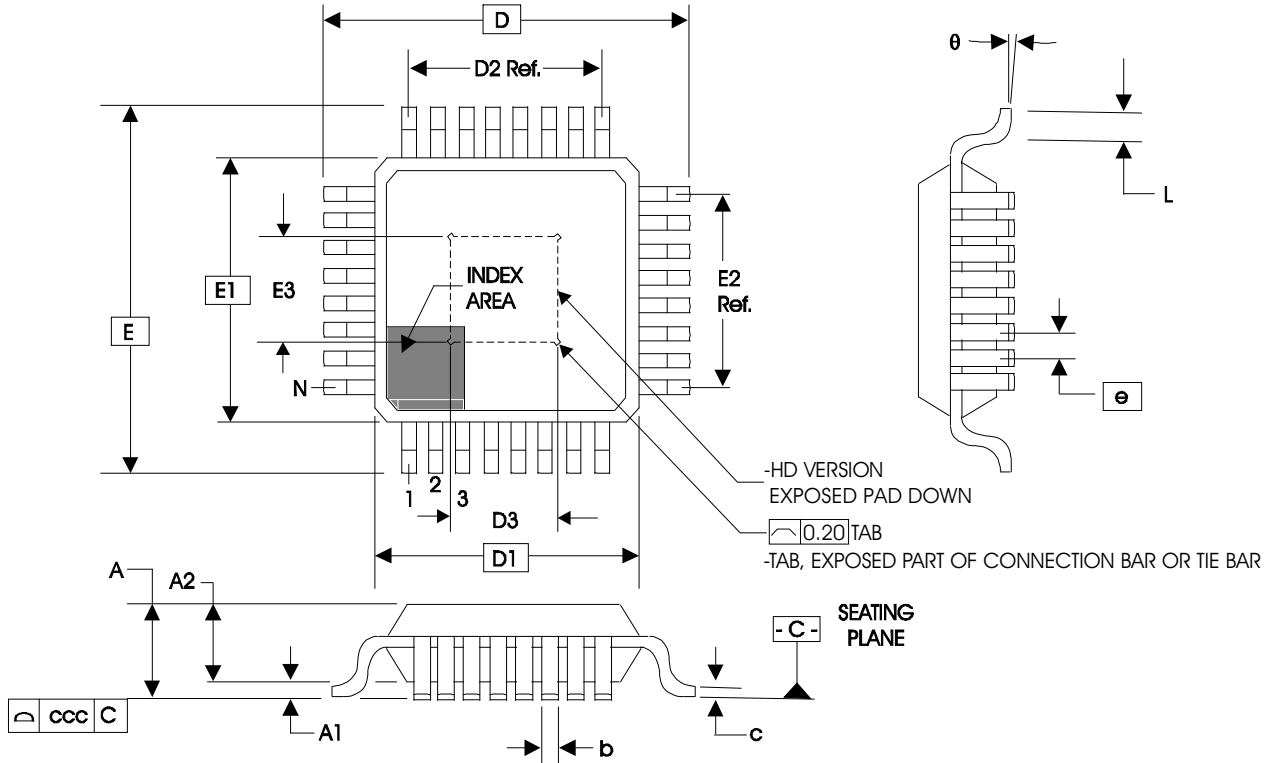

Table 9. Package Dimensions 32 Lead TQFP, E-Pad

JEDEC Variation: ABC - HD			
All Dimensions in Millimeters			
Symbol	Minimum	Nominal	Maximum
N	32		
A			1.20
A1	0.05	0.10	0.15
A2	0.95	1.00	1.05
b	0.30	0.35	0.40
c	0.09		0.20
D & E	9.00 Basic		
D1 & E1	7.00 Basic		
D2 & E2	5.60 Ref.		
D3 & E3	3.0		4.0
e	0.80 Basic		
L	0.45	0.60	0.75
θ	0°		7°
ccc			0.10

Reference Document: JEDEC Publication 95, MS-026

## Ordering Information

**Table 9. Ordering Information**

<b>Part/Order Number</b>	<b>Marking</b>	<b>Package</b>	<b>Shipping Packaging</b>	<b>Temperature</b>
840S07BYILF	ICS840S07BIL	Lead-Free, 32 Lead TQFP, E-Pad	Tray	-40°C to 85°C
840S07BYILFT	ICS840S07BIL	Lead-Free, 32 Lead TQFP, E-Pad	Tape & Reel	-40°C to 85°C

## Revision History

Revision Date	Description of Change
April 14, 2016	<ul style="list-style-type: none"><li>▪ Removed ICS from part number where needed.</li><li>▪ Ordering Information - removed quantity from tape and reel. Deleted LF note below table.</li><li>▪ Updated data sheet header and footer.</li></ul>



Corporate Headquarters  
6024 Silver Creek Valley Road  
San Jose, CA 95138 USA  
[www.IDT.com](http://www.IDT.com)

Sales  
1-800-345-7015 or 408-284-8200  
Fax: 408-284-2775  
[www.IDT.com/go/sales](http://www.IDT.com/go/sales)

Tech Support  
[www.idt.com/go/support](http://www.idt.com/go/support)

DISCLAIMER Integrated Device Technology, Inc. (IDT) reserves the right to modify the products and/or specifications described herein at any time, without notice, at IDT's sole discretion. Performance specifications and operating parameters of the described products are determined in an independent state and are not guaranteed to perform the same way when installed in customer products. The information contained herein is provided without representation or warranty of any kind, whether express or implied, including, but not limited to, the suitability of IDT's products for any particular purpose, an implied warranty of merchantability, or non-infringement of the intellectual property rights of others. This document is presented only as a guide and does not convey any license under intellectual property rights of IDT or any third parties.

IDT's products are not intended for use in applications involving extreme environmental conditions or in life support systems or similar devices where the failure or malfunction of an IDT product can be reasonably expected to significantly affect the health or safety of users. Anyone using an IDT product in such a manner does so at their own risk, absent an express, written agreement by IDT.

Integrated Device Technology, IDT and the IDT logo are trademarks or registered trademarks of IDT and its subsidiaries in the United States and other countries. Other trademarks used herein are the property of IDT or their respective third party owners.

For datasheet type definitions and a glossary of common terms, visit [www.idt.com/go/glossary](http://www.idt.com/go/glossary).

Copyright ©2016 Integrated Device Technology, Inc. All rights reserved.

## Looking for pricing, stock, or lifecycle information?

Click below to explore more details on WIN SOURCE:

- ⊖ [View 840S07BYILF on WIN SOURCE](#)
- ⊖ [IDT, Integrated Device Technology Inc Information](#)

## Optimize Your Supply Chain with WIN SOURCE Solutions

- ✓ Global Sourcing Solution
- ✓ Obsolete Management
- ✓ Cost Control Management
- ✓ Shortage Management
- ✓ Alternative Solution
- ✓ Excess Inventory Management